

\_ METAL IS OUR WORLD

# Tools for Turning

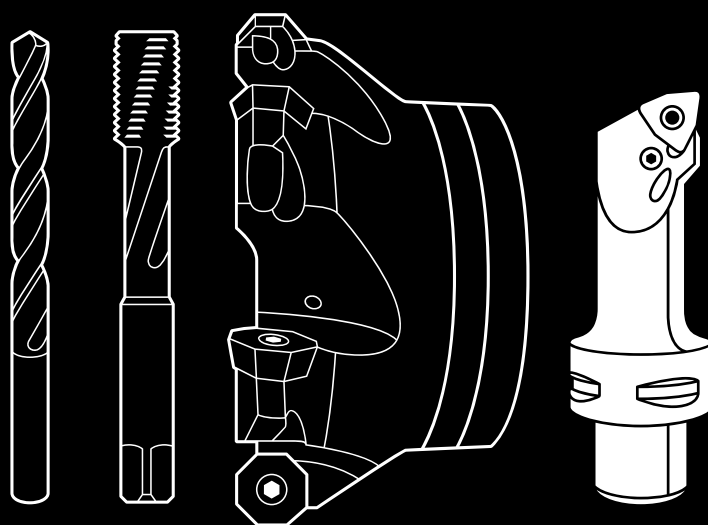

# How to find and order your tool solution:



## Personal – worldwide

You can contact us by phone, fax or e-mail. The contact details for your local contact can be found on our website at: [walter-tools.com](http://walter-tools.com)



## The Walter Hybrid catalogues and brochures

show the entire standard range under the Walter, Walter Titex, Walter Prototyp and Walter Multiply competence brands – in print or in digital format – with product range overviews, product data, cutting data recommendations and much more. Including links to our machining navigator, Walter GPS, or the Walter TOOLSHOP with the chance to order directly.

At [walter-tools.com](http://walter-tools.com), you can access and order your Walter products quickly and conveniently online – via smartphone, tablet or PC.

The benefit for you: Direct access from any device, displayed in an optimised form, at any time.

## Walter online catalogue



### Tool-specific search

You can find products in the Walter online catalogue using the familiar structure of our product catalogue as well as filter and search functions. Other features: A shopping function and links to drawings and models.

## Walter GPS



### Application-based search

With Walter GPS, it takes just a few steps to find the optimum machining solution for your component, online and offline – and the solution can be transferred directly to the Walter TOOLSHOP if required.

## Walter Innotime®



### Component-based search

With Walter Innotime®, you can find the most cost-effective machining solution for your component, including all the tools, machining steps and machining parameters required for this. Simply by uploading your 3D model.

## Digital ordering methods



**TOOLSHOP**



**EDI B2B**

### Walter TOOLSHOP & EDI

The Walter TOOLSHOP offers customers opportunities to find information and place orders quickly.

EDI (electronic data interchange) also makes it possible to exchange documents (e.g. orders) – even special tools can be ordered.

# A - Turning

## A1 - ISO turning

<b>Indexable inserts</b>	Program	Order pages
ISO indexable inserts – Negative basic shape	A 10	A 20
ISO indexable inserts – Positive basic shape	A 13	A 39
Inserts copy turning system – WL	A 16	A 62
ISO indexable inserts – CBN/PCD/ceramic	A 17	A 64

<b>Walter Turn turning tools – External machining</b>	Program	Order pages
Shank tools – Negative basic shape	A 84	A 105
Shank tools – Positive basic shape	A 90	A 162
Shank tool – WL copy turning system	A 94	A 202
Shank tool – Ceramic indexable inserts	A 96	A 208
Walter Capto™ turning toolholders	A 97	A 212
Walter Capto™ – WL copy turning system	A 102	A 248
Walter Capto™ – Negative basic shape, ceramic	A 103	A 251
Walter Capto™ turning toolholders – Turning and milling centres	A 104	A 252

<b>Walter Turn turning tools – Internal machining</b>	Program	Order pages
Boring bars – Negative basic shape	A 258	A 274
Boring bars – Positive basic shape	A 260	A 291
Boring bars – WL copy turning system	A 264	A 324
Boring bar adaptor	A 265	A 329
Boring bars – Walter Capto™	A 266	A 330
Vibration-damped boring bar adaptor – Accure-tec®	A 268	A 344
Boring bars – QuadFit exchangeable head	A 269	A 352

## A2 - Grooving

<b>Cutting inserts</b>	Program	Order pages
Single-, double- and multi-edged cutting inserts	A 366	A 376
Single-edged interchangeable heads	A 374	A 410

<b>Shank tools</b>	Program	Order pages
Shank tools/parting blades	A 422	A 438
Walter Capto™ groove turning holders	A 432	A 548
Boring bars	A 434	A 558
QuadFit exchangeable head	A 437	A 576

## A3 - Thread turning

<b>Indexable inserts</b>	Program	Order pages
Indexable inserts	A 578	A 580

<b>Walter TS threading tools</b>	Program	Order pages
Walter TS threading tools	A 594	A 596

# Technologies at Walter

## **((( Accure-tec®**

The patented Walter Accure-tec® technology ensures maximum vibration damping on boring bars for turning and adaptors for milling. Ideal for turning, milling and drilling operations involving extended tool applications.

## **Drion-tec®**

Drion-tec® is the name for Walter's drilling and reaming tool solutions with a replaceable cutting edge – both with indexable inserts and exchangeable inserts. Drion-tec® drills are set apart by their cost-efficiency, high precision and versatility. Thanks to a wide product range, they are suitable for specialised mass production as well as for specific applications and mixed-mode manufacturing.

## **Groov-tec™**

Groov-tec™ is the latest generation of Walter high-performance cutting tools. These are characterised by maximum stability, which enables high process parameters (feeds/speeds/depth of cut) and leads to maximum toolholder and indexable insert service life. At the same time, the systems maximise process reliability by means of controlled chip breaking.

## **Krato-tec®**

Krato-tec® is a unique Walter coating technology for solid carbide tools. The core of this consists of an extraordinarily fracture-resistant AlTiN multi-layer coating with a textured top layer. The special layer architecture is highly wear- and adhesion-resistant, even at high cutting speeds, and ensures the tools have universal application.

## **Tiger-tec® Gold**

Tiger-tec® Gold, the new Walter generation platform for unique indexable insert coatings, enables maximum tool life and process reliability. The new grades are based on PVD, CVD or ULP technology, depending on the application. Unique coating properties, protected by multiple patents, guarantee the best protection against tool life-limiting types of wear and ensure outstanding performance.

## **Tiger-tec® Silver**

With Tiger-tec® Silver, Walter is offering a world first in coating technology for indexable inserts. The special aluminium oxide layer with optimised microstructure reduces wear during turning, milling and drilling operations, and increases toughness and temperature resistance for significantly higher cutting data.

## **Thread-tec™**

Thread-tec™ refers to selected Walter threading tools with high performance and process reliability. Combining the most recent technical developments and proven properties in tool geometries and coatings, Thread-tec™ is a comprehensive product range featuring a variety of lengths and dimensions. This makes the assortment suitable for any application – whether for thread milling, forming, or tapping.

## **Thrill-tec™**

Thrill-tec™ circular drill/thread mills combine three functions in one tool and operation: Chamfering, drilling core holes and producing threads. The tools boast a special combination of substrate, coating and geometry, resulting in long tool life. Bringing together multiple machining steps makes incredibly short machining times possible and reduces the number of tools used and machine slots required.

## **Walter BLAXX**

Walter BLAXX is the benchmark for a new generation of milling cutters: The milling bodies are extremely robust thanks to their special surface treatment. The milling systems, which are mainly positioned tangentially, are equipped with Tiger-tec® indexable inserts. Tools with the "Walter BLAXX" designation combine high wear resistance with unbeatable performance data.



## Walter Xpress

Walter Xpress is the rapid ordering and delivery service offered by Walter MultiPLY for high-quality special tools. It is available for around 10,000 tool varieties, with a maximum delivery time of two to four weeks from the order date. The ordering process is clearly structured and guarantees absolute planning security. Quotations for all enquiries are calculated and provided within 24 hours.

## Walter Precision XT

Precision boring tools are always used to finish an existing bore or to improve the precision of existing bores, for instance by correcting their position, narrowing the hole tolerance, or enhancing the surface quality. Precision boring is typically performed using a depth of cut < 0.5 mm (0.02 inches).

## Walter Boring XT

Tools for rough boring are used to expand existing bores. Material removal is a key element of this process. The bore to be enlarged is machined in advance or created using casting or forging processes. The rough boring tools themselves can also be used for radial offsetting and multi-edge boring.

## XD Technology

Walter Titex solid carbide drilling and reaming tools stand for precision, high performance and cost-efficiency when drilling in practically any material. Walter Titex XD Technology offers the greatest precision and cost-efficiency in deep-hole drilling operations up to  $70 \times D_c$  without pecking.

## Xill-tec®

With Xill-tec®, the solid carbide milling cutters from the MC230 Advance product range, Walter offers a uniquely wide range, with different dimensions, numbers of teeth and shank versions. This means that users are well-equipped for all conceivable milling operations and ISO materials. Universal use – with excellent quality.

## Xtra-tec®

Xtra-tec® indexable insert milling cutters and drills guarantee extremely soft cutting action and optimal surface quality on almost all materials. Indexable inserts with highly positive geometries and the Tiger-tec® coating have a particularly beneficial hardness/toughness ratio. For maximum productivity and process reliability.

## Xtra-tec® XT

Xtra-tec® XT is the latest generation of Walter milling tools. As the "Xtended" Xtra-tec® technology, it offers a completely new perspective on productivity and process reliability. It can cover nearly all milling operations in every common material group: More reliable, productive, cost-efficient than ever before – all while compensating for the CO<sub>2</sub> emissions through Walter Green.

## X-treme Evo

For Walter, the X-treme Evo DC260 & DC160 Advance solid carbide drills as well as the X-treme Evo Plus DC180 Supreme and X-treme Evo 3 DC183 Supreme are the embodiment of the "next generation of drilling", offering versatility for a wide range of materials and machine concepts – with outstanding tool life, productivity and process reliability.

## Technologies at Walter (continued)



Walter Capto™ is a modular tool adaptor system. It is suitable for all turning, milling, drilling and threading processes. Its ISO-standardised polygon taper absorbs torsional moments and bending moments extremely well and ensures optimal repeat accuracy.



Walter ConeFit is an extremely flexible solid carbide milling system with a wide range of high-performance exchangeable heads and shaft variants. Its conical thread can self-centre, thereby guaranteeing maximum stability and concentricity.

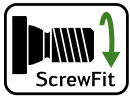

Walter ScrewFit users benefit from maximum flexibility. Its modular interface is suitable for a wide variety of boring bars and adaptors and a wide range of tool diameters and lengths for milling and drilling.



The precision-ground QuadFit interface with taper and support face characterises the precision of the vibration-damped boring bars for turning and thread turning with Walter Accure-tec® technology. The exchangeable head system, which can be rotated by 180°, makes it possible to rapidly replace tools with high indexing accuracy.



In turning and grooving operations, the Walter precision cooling system provides cooling at the centre of the chip formation. Its dual coolant jets are directed precisely onto the flank and rake faces. In drilling operations, the coolant jets exit close to the cutting edge. This system provides significantly increased tool life, improved chip breaking and chip removal, greater efficiency and higher quality.



Walter DeVibe is an anti-vibration technology for thread milling cutters. At its core, it consists of a »calming chamfer« that reduces the clearance angle on the flank face. This supports the tool; vibrations are minimised. DeVibe enables higher surface qualities and cutting data, particularly for metric fine threads – regardless of clamping conditions, changing cutting data or the milling strategy.



“Flash” refers to specialised solid carbide milling cutters for high-feed milling. Their end-face geometry reduces the chip thickness “h” and therefore enables an extremely high feed per tooth. Forces that occur are diverted axially towards the centre of the tool, which helps to stabilise the machining process.

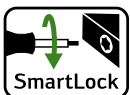

On Walter turning toolholders with “SmartLock”, the clamping screw can be operated from the side of the tool. This makes it possible to index the inserts in the machine quickly and easily. Tool change times are reduced as a result. Ideal for use on CNC lathe and multi-spindle machines.

# Tiger-tec<sup>®</sup> Gold



[tigertec-gold.walter](http://tigertec-gold.walter)

 **WALTER**  
Engineering Kompetenz

# The structure of the new Walter General Catalogue

The new Walter General Catalogue presents information about products and applications in a comprehensive and clear manner as an e-document – including direct links to the Walter online catalogue.

ISO turning

### ISO indexable inserts – Negative basic shape

Machining	Medium machining			Roughing	
Geometry	MM5	MP5	MU5 <span style="color: red; font-weight: bold;">NEW</span>	MK5	NRS
Insert basic shape	C, D, S, T, V, W	C, D, S, T, V, W	C, D, S, T, W	C, D, S, T, V, W	C, D, S, T, W
P Steel	●	●●	●●●	●	●
M Stainless steel	●●	●●	●●●	●●	●
K Cast iron	●	●	●	●●	●●
N NF metals	●	●	●	●	●
S Materials with difficult cutting properties	●●	●●	●	●	●●
H Hard materials					
O Other					
a <sub>p</sub> [mm]	0.5–4.5	0.5–8.0	0.5–7.0	0.2–8.0	0.8–9.0
f [mm]	0.10–0.45	0.10–0.55	0.15–0.55	0.10–0.80	0.13–0.60
Page in catalogue	13	13	14	14	
QR code					
<a href="http://www.walter-tools.com/woc/">www.walter-tools.com/woc/</a>	MM5	MP5	MU5	MK5	NRS

Machining	Roughing				
Geometry	NRT	RM5	RP5	RP7	RK5
Insert basic shape	C, S	C, D, S, T, W	C, D, R, S, T, W	C, S, T, W	C, D, R, S, T, V, W
P Steel		●●	●●●	●●	●
M Stainless steel		●●	●●●	●●	●
K Cast iron		●	●	●●	●●
N NF metals		●	●	●	●
S Materials with difficult cutting properties	●●	●●	●	●	●
H Hard materials					
O Other					
a <sub>p</sub> [mm]	0.8–9.0	1.2–8.0	0.8–13.0	0.8–10.0	0.6–8.0
f [mm]	0.18–0.80	0.20–0.80	0.15–1.20	0.18–1.00	0.15–0.90
Page in catalogue	15	15	15	16	16
QR code					
<a href="http://www.walter-tools.com/woc/">www.walter-tools.com/woc/</a>	NRT	RM5	RP5	RP7	RK5

**WALTER SELECT** ●● Primary application ● Other application

ISO indexable inserts – Negative basic shape 9

## Product range overviews with applications, materials and QR codes at a glance

The product range overviews include icons indicating applications, images of the products, and the range of materials for which the products can be used; if relevant, they also include shank versions, clamping systems and other important information. This means that you can immediately see which product you need – and go directly to more detailed information about it by scanning the corresponding QR code or typing the link provided into your browser.

**NEW** Tools with this icon are product innovations and are displayed in this way in the product range overviews.

Indexable inserts and tools with these red icons are new to the range and are labelled in this way on the ordering page.



## Scan the QR code

to go directly to the sub-page for the corresponding product in the Walter online catalogue. The brief overview contains an image of the tool or product, icons representing applications and other information, and the main and secondary applications in the ISO materials sector.



MU5

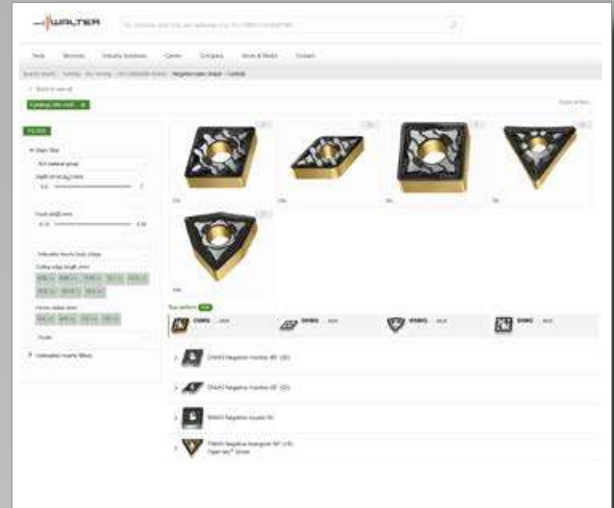
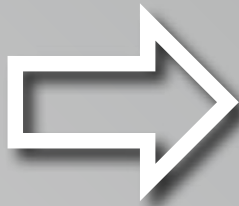

## Direct link

As well as scanning the QR code, you can also type the link directly into your browser:

[www.walter-tools.com/woc/MU5](http://www.walter-tools.com/woc/MU5).

In the e-document, you can of course click on the link itself.

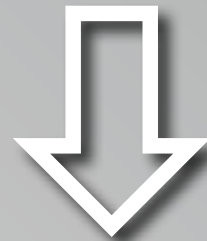



















## Detailed overview of product data

Depending on the product, the information available here or on the following product details page will include dimensions, corresponding indexable inserts, adaptors, and accessories, as well as direct links to additional information such as cutting data recommendations via Walter GPS or technical information like assembly instructions, limit speeds and much more.

Designation	d	r	f	v <sub>c</sub>	Materials
	mm	mm	mm	mm	P M K N S H Q
-.MUS (27)	9.5-12.7	0.4-1.0	0.15-0.55	0.5-5	
WMA00000808.MUS.VMP2015	9.5	0.8	0.15-0.35	0.6-3	P M K N S H Q
WMA00000808.MUS.VSHQ205	9.5	0.8	0.15-0.35	0.6-3	P M K N S H Q
WMA00000808.MUS.VMP1105	9.5	0.8	0.15-0.35	0.6-3	P M K N S H Q
WMA00000808.MUS.VMP205	9.5	0.8	0.15-0.35	0.6-3	P M K N S H Q
WMA00000808.MUS.VMP210	9.5	0.8	0.15-0.35	0.6-3	P M K N S H Q
WMA00000808.MUS.VMP100	9.5	0.8	0.15-0.35	0.6-3	P M K N S H Q
WMA0000112.MUS.VMP210	12.7	1.2	0.2-0.6	1-5	P M K N S H Q
WMA0000108.MUS.VMP205	12.7	0.8	0.15-0.4	0.6-5	P M K N S H Q
WMA0000104.MUS.VSHQ205	12.7	0.4	0.15-0.3	0.5-4	P M K N S H Q
WMA0000104.MUS.VMP105	12.7	0.4	0.15-0.3	0.5-4	P M K N S H Q

## ISO indexable inserts – Negative basic shape

Machining	Finishing operation				Medium machining
					
	<b>FW5</b>	<b>FM5</b>	<b>NFT</b>	<b>FP5</b>	<b>MW5</b>
<b>Indexable inserts basic shape</b>	C, D, T, W	C, D, S, T, V, W	C, D, V	C, D, S, T, V, W	C, D, T, W
<b>P</b> Steel	●●	●		●●	●●
<b>M</b> Stainless steel	●●	●●	●		●●
<b>K</b> Cast iron	●●			●	●●
<b>N</b> NF metals			●		
<b>S</b> Materials with difficult cutting properties	●	●●	●●		●
<b>H</b> Hard materials					
<b>O</b> Other					
<b>a<sub>p</sub></b> [mm]	0,3–3,0	0,1–2,0	0,1–2,0	0,08–2,5	0,8–4,0
<b>f</b> [mm]	0,10–0,65	0,03–0,25	0,04–0,20	0,04–0,28	0,15–0,70
<b>Page in catalogue</b>	A 20	A 20	A 20	A 20	A 20
<b>QR code</b>					
<a href="http://www.walter-tools.com/woc/">www.walter-tools.com/woc/</a>	FW5	FM5	NFT	FP5	MW5

Machining	Medium machining				
					
	<b>MN3</b>	<b>NMS</b>	<b>MS3</b>	<b>NMT</b>	<b>MP3</b>
<b>Indexable inserts basic shape</b>	C, D, V, W	C, D, S, T, V, W	C, D, T, V, W	C, D, W	C, D, S, T, V, W
<b>P</b> Steel	●		●	●●	●●
<b>M</b> Stainless steel	●	●	●		
<b>K</b> Cast iron					●
<b>N</b> NF metals	●●		●		
<b>S</b> Materials with difficult cutting properties	●	●●	●●	●●	
<b>H</b> Hard materials					
<b>O</b> Other					
<b>a<sub>p</sub></b> [mm]	0,5–4,0	0,5–3,5	0,2–5,0	0,4–4,0	0,3–3,5
<b>f</b> [mm]	0,05–0,40	0,08–0,45	0,02–0,50	0,08–0,32	0,06–0,40
<b>Page in catalogue</b>	A 20	A 20	A 20	A 20	A 20
<b>QR code</b>					
<a href="http://www.walter-tools.com/woc/">www.walter-tools.com/woc/</a>	MN3	NMS	MS3	NMT	MP3











## ISO indexable inserts – Negative basic shape

Machining	Medium machining				Roughing
<b>Geometry</b>	<b>MM5</b>	<b>MP5</b>	<b>MU5</b>	<b>MK5</b>	<b>NRS</b>
<b>Indexable inserts basic shape</b>	C, D, S, T, V, W	C, D, S, T, V, W	C, D, S, T, W	C, D, S, T, V, W	C, D, S, T, W
<b>P</b> Steel	●	●●	●●	●	
<b>M</b> Stainless steel	●●		●●		●
<b>K</b> Cast iron		●	●	●●	
<b>N</b> NF metals					
<b>S</b> Materials with difficult cutting properties	●●		●		●●
<b>H</b> Hard materials					
<b>O</b> Other					
<b>a<sub>p</sub> [mm]</b>	0,5–4,5	0,5–8,0	0,5–7,0	0,2–8,0	0,8–9,0
<b>f [mm]</b>	0,10–0,45	0,10–0,55	0,15–0,55	0,10–0,80	0,13–0,60
<b>Page in catalogue</b>	A 20	A 20	A 20	A 20	A 20
<b>QR code</b>					
<a href="http://www.walter-tools.com/woc/">www.walter-tools.com/woc/</a>	MM5	MP5	MU5	MK5	NRS











Machining	Roughing				
<b>Geometry</b>	<b>NRT</b>	<b>RM5</b>	<b>RP5</b>	<b>RP7</b>	<b>RK5</b>
<b>Indexable inserts basic shape</b>	C, S	C, D, S, T, W	C, D, R, S, T, W	C, S, T, W	C, D, R, S, T, V, W
<b>P</b> Steel		●	●●	●●	
<b>M</b> Stainless steel		●●	●		
<b>K</b> Cast iron			●	●●	●●
<b>N</b> NF metals					
<b>S</b> Materials with difficult cutting properties	●●	●●			
<b>H</b> Hard materials					●
<b>O</b> Other					
<b>a<sub>p</sub> [mm]</b>	0,8–9,0	1,2–8,0	0,8–13,0	0,8–10,0	0,6–8,0
<b>f [mm]</b>	0,18–0,80	0,20–0,80	0,15–1,20	0,18–1,00	0,15–0,90
<b>Page in catalogue</b>	A 20	A 20	A 20	A 20	A 20
<b>QR code</b>					
<a href="http://www.walter-tools.com/woc/">www.walter-tools.com/woc/</a>	NRT	RM5	RP5	RP7	RK5











## ISO indexable inserts – Negative basic shape

Machining	Roughing		Heavy machining	
				
<b>Geometry</b>	<b>RK7</b>	<b>HU3</b>	<b>HU5</b>	<b>HU7</b>
<b>Indexable inserts basic shape</b>	C, D, S, T, W	C, D, S, T, W	C, D, S	C, S, T
<b>P</b> Steel		●●	●	●●
<b>M</b> Stainless steel		●	●●	●
<b>K</b> Cast iron	●●	●	●	●●
<b>N</b> NF metals				
<b>S</b> Materials with difficult cutting properties			●●	
<b>H</b> Hard materials	●●			
<b>O</b> Other				
<b>a<sub>p</sub> [mm]</b>	0,8–8,0	0,8–12,0	1,0–12,0	1,5–17,0
<b>f [mm]</b>	0,20–0,80	0,25–1,20	0,25–1,20	0,40–1,60
<b>Page in catalogue</b>	A 20	A 20	A 20	A 20
<b>QR code</b>				
<a href="http://www.walter-tools.com/woc/">www.walter-tools.com/woc/</a>	RK7	HU3	HU5	HU7























## Positive basic shape 5°/7°/11° – Carbide

Machining	Finishing operation				
					
<b>Geometry</b>	<b>FW4</b>	<b>FL2</b>	<b>FN2</b>	<b>FM2</b>	<b>FP2</b>
<b>Indexable inserts basic shape</b>	C, D, T	C, D, V	C, D, S, T, V, W	C, D, S, T, V, W	C, D, T, V
<b>P</b> Steel	●●	●●	●	●●	●●
<b>M</b> Stainless steel	●●	●●	●	●●	●●
<b>K</b> Cast iron	●●	●●	●	●	●●
<b>N</b> NF metals			●●	●●	●
<b>S</b> Materials with difficult cutting properties	●	●	●	●●	●
<b>H</b> Hard materials					
<b>O</b> Other			●		
<b>a<sub>p</sub> [mm]</b>	0,1–2,5	0,1–1,5	0,12–3,5	0,1–3,5	0,1–3,0
<b>f [mm]</b>	0,03–0,50	0,04–0,20	0,02–0,30	0,02–0,30	0,01–0,30
<b>Page in catalogue</b>	A 39	A 39	A 39	A 39	A 39
<b>QR code</b>					
<a href="http://www.walter-tools.com/woc/">www.walter-tools.com/woc/</a>	FW4	FL2	FN2	FM2	FP2

Machining	Finishing operation				
					
<b>Geometry</b>	<b>FX4</b>	<b>FM4</b>	<b>FP4</b>	<b>FM6</b>	<b>FP6</b>
<b>Indexable inserts basic shape</b>	C, D, T, V	C, D, R, S, T, V, W	C, D, R, S, T, V, W	C, D, S, T, V	C, D, S, T, V, W
<b>P</b> Steel	●●	●	●●	●	●●
<b>M</b> Stainless steel	●	●●	●	●●	●
<b>K</b> Cast iron	●		●		●
<b>N</b> NF metals					
<b>S</b> Materials with difficult cutting properties		●●	●	●●	●
<b>H</b> Hard materials					
<b>O</b> Other					
<b>a<sub>p</sub> [mm]</b>	0,05–2,5	0,1–5,0	0,1–5,0	0,3–2,5	0,3–2,5
<b>f [mm]</b>	0,02–0,25	0,02–0,40	0,02–0,40	0,08–0,32	0,06–0,32
<b>Page in catalogue</b>	A 39	A 39	A 39	A 39	A 39
<b>QR code</b>					
<a href="http://www.walter-tools.com/woc/">www.walter-tools.com/woc/</a>	FX4	FM4	FP4	FM6	FP6

## Positive basic shape 5°/7°/11° – Carbide









Machining	Finishing operation		Medium machining		
					
Geometry	FK6	MW4	MN2	MM4	MP4
Indexable inserts basic shape	C, D, S, T, V	C, D, T	C, D, R, S, T, V, W	C, D, S, T, V, W	C, D, S, T, V, W
P Steel	●	●●	●	●	●●
M Stainless steel	●	●●	●	●●	●
K Cast iron	●●	●●	●	●	●
N NF metals			●●		
S Materials with difficult cutting properties	●	●	●	●●	●
H Hard materials					
O Other			●		
a <sub>p</sub> [mm]	0,3–2,5	0,5–4,5	0,5–6,0	0,1–3,5	0,3–3,5
f [mm]	0,06–0,32	0,12–0,55	0,02–0,80	0,04–0,35	0,06–0,35
Page in catalogue	A 39	A 39	A 39	A 39	A 39
QR code					
<a href="http://www.walter-tools.com/woc/">www.walter-tools.com/woc/</a>	FK6	MW4	MN2	MM4	MP4

Machining	Medium machining				Roughing
					
Geometry	MK4	MP6	..GN	..MR	RM4
Indexable inserts basic shape	C, D, S, T, V	C, D, T, V	T	T	C, D, R, S, T, V, W
P Steel	●	●●	●●	●●	●
M Stainless steel	●	●●	●	●	●●
K Cast iron	●●	●	●	●●	●
N NF metals					
S Materials with difficult cutting properties	●	●	●	●	●●
H Hard materials					
O Other					
a <sub>p</sub> [mm]	0,4–3,5	0,4–4,0	0,4–3,0	0,4–4,0	0,2–7,0
f [mm]	0,08–0,35	0,08–0,40	0,10–0,30	0,12–0,30	0,08–1,20
Page in catalogue	A 39	A 39	A 56	A 56	A 39
QR code					
<a href="http://www.walter-tools.com/woc/">www.walter-tools.com/woc/</a>	MK4	MP6	GN	MR	RM4











WALTER SELECT

●● Primary application ● Other application











## Positive basic shape 5°/7°/11° – Carbide











Machining	Roughing			Heavy machining
				
<b>Geometry</b>	<b>RP4</b>	<b>RK4</b>	<b>RK6</b>	<b>HU6</b>
<b>Indexable inserts basic shape</b>	C, D, R, S, T, V, W	C, D, R, S, T, V, W	C, D, S, T, V	R
<b>P</b> Steel	●●	●		●●
<b>M</b> Stainless steel	●	●		
<b>K</b> Cast iron	●	●●	●●	●●
<b>N</b> NF metals				
<b>S</b> Materials with difficult cutting properties	●	●		
<b>H</b> Hard materials			●	
<b>O</b> Other				
<b>a<sub>p</sub> [mm]</b>	0,2–7,0	0,4–7,0	0,2–5,0	1,0–15,0
<b>f [mm]</b>	0,08–1,20	0,08–1,20	0,08–0,50	0,12–1,70
<b>Page in catalogue</b>	A 39	A 39	A 39	A 47
<b>QR code</b>				
<a href="http://www.walter-tools.com/woc/">www.walter-tools.com/woc/</a>	RP4	RK4	RK6	HU6

## Inserts copy turning system – WL











Machining	Finishing operation		Medium machining		
					
<b>Geometry</b>	<b>FM4</b>	<b>FP4</b>	<b>MM4</b>	<b>MP4</b>	<b>MU6</b>
<b>Indexable inserts basic shape</b>	WL	WL	WL	WL	WL
<b>P Steel</b>	●	●●	●	●●	●●
<b>M Stainless steel</b>	●●	●	●●	●	●●
<b>K Cast iron</b>		●	●	●	●●
<b>N NF metals</b>					
<b>S Materials with difficult cutting properties</b>	●●	●	●●	●	●●
<b>H Hard materials</b>					●
<b>O Other</b>					
<b>a<sub>p</sub> [mm]</b>	0,1–2,0	0,1–2,0	0,4–2,5	0,4–2,5	0,5–2,5
<b>f [mm]</b>	0,04–0,25	0,05–0,25	0,08–0,40	0,08–0,40	0,12–0,45
<b>Page in catalogue</b>	A 62	A 62	A 62	A 62	
<b>QR code</b>					
<a href="http://www.walter-tools.com/woc/">www.walter-tools.com/woc/</a>	FM4	FP4	MM4	MP4	MU6





## ISO indexable inserts – CBN/PCD/ceramic

Cutting tool material	CBN				
					
<b>Geometry</b>	<b>EM</b>	<b>TS</b>	<b>TS-MW</b>	<b>TM</b>	<b>TM-M</b>
<b>Indexable inserts basic shape</b>	C, D, V	C, D, S, T, V, W	C	C, D, S, T, V, W	C, D
<b>P</b> Steel					
<b>M</b> Stainless steel					
<b>K</b> Cast iron		●●			
<b>N</b> NF metals					
<b>S</b> Materials with difficult cutting properties	●●				
<b>H</b> Hard materials		●●	●●	●●	●●
<b>O</b> Other					
<b>a<sub>p</sub> [mm]</b>	0,1–1,0	0,05–2,0	0,1–0,5	0,1–1,0	0,1–1,0
<b>f [mm]</b>	0,05–0,25	0,02–0,30	0,05–0,20	0,05–0,30	0,05–0,30
<b>Page in catalogue</b>	<b>A 64</b>	<b>A 64</b>	<b>A 70</b>	<b>A 64</b>	<b>A 64</b>
<b>QR code</b>					
<a href="http://www.walter-tools.com/woc/">www.walter-tools.com/woc/</a>	EM	TS	TS-MW	TM	TM-M



Cutting tool material	CBN			Ceramic	
					
<b>Geometry</b>	<b>TM-MW</b>	<b>TS-0</b>	<b>TM-S</b>	<b>E</b>	<b>T01020</b>
<b>Indexable inserts basic shape</b>	C, D	R	C, R, S	R	C, R, S
<b>P</b> Steel					
<b>M</b> Stainless steel					
<b>K</b> Cast iron		●●	●●		
<b>N</b> NF metals					
<b>S</b> Materials with difficult cutting properties				●●	●●
<b>H</b> Hard materials	●●		●		●
<b>O</b> Other					
<b>a<sub>p</sub> [mm]</b>	0,1–1,0	0,1–5,0	0,1–5,0	0,1–3,6	0,1–4,5
<b>f [mm]</b>	0,05–0,50	0,05–0,40	0,05–0,50	0,10–0,32	0,10–0,42
<b>Page in catalogue</b>	<b>A 64</b>	<b>A 65</b>	<b>A 64</b>		<b>A 79</b>
<b>QR code</b>					
<a href="http://www.walter-tools.com/woc/">www.walter-tools.com/woc/</a>	TM-MW	TS-0	TM-S	E	T01020

## ISO indexable inserts – CBN/PCD/ceramic

Cutting tool material	Keramik			PCD	
					
Geometry	T02020	SM	SM-MWS	T-FS	W-FS
Indexable inserts basic shape	C, D, S, T, W	C, D, S, T, V, W	C	C, D, V	C, D, S, T, V
P Steel					
M Stainless steel					
K Cast iron	●●				
N NF metals				●●	●●
S Materials with difficult cutting properties				●	●
H Hard materials		●●	●●		
O Other				●●	●●
$a_p$ [mm]	0,1–6,0	0,1–1,0	0,1–1,0	0,05–4,0	0,05–4,0
$f$ [mm]	0,10–0,80	0,05–0,30	0,05–0,35	0,03–0,38	0,03–0,38
Page in catalogue	A 79	A 79	A 79	A 73	A 73
QR code					
<a href="http://www.walter-tools.com/woc/">www.walter-tools.com/woc/</a>	T02020	SM	SM-MWS	T-FS	W-FS

Cutting tool material	PKD	
		
Geometry	FS-M	FS-9
Indexable inserts basic shape	C, D	C, S, T
P Steel		
M Stainless steel		
K Cast iron		
N NF metals	●●	●●
S Materials with difficult cutting properties	●	●
H Hard materials		
O Other	●●	●●
$a_p$ [mm]	0,1–2,0	0,05–15,3
$f$ [mm]	0,08–0,20	0,03–0,38
Page in catalogue	A 73	A 73
QR code		
<a href="http://www.walter-tools.com/woc/">www.walter-tools.com/woc/</a>	FS-M	FS-9

## Indexable inserts for copy turning system – WL CBN inserts

Machining	Medium machining	
		
Geometry	TM	
Indexable inserts basic shape	WL	
P Steel		
M Stainless steel		
K Cast iron		
N NF metals		
S Materials with difficult cutting properties		
H Hard materials	●●	
O Other		
$a_p$ [mm]	0,1–2,5	
$f$ [mm]	0,02–0,50	
Page in catalogue	A 83	
QR code		
<a href="http://www.walter-tools.com/woc/">www.walter-tools.com/woc/</a>	TM	

# Turning Insert – Negative rhombic 80°

## CNMG / CNGG / CNMA / CNMM

### Tiger-tec® Gold

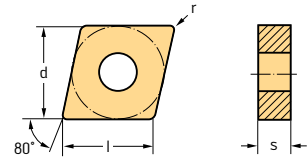

#### Indexable inserts

Designation	l mm	r mm	f mm	ap mm	P								M				K			N		S				
					WKP01G	WPP05G	WPP10G	WPP20G	WMP20S	WPP30G	WKP30S	WEP10C	WSM01	WSM10S	WMP20S	WSM20S	WSM30S	WKP01G	WKK10S	WKK20S	WKP30S	WNN10	WN10	WSM01	WSM10S	WSM20S
CNMG120404-FW5	12.9	0.4	0.10-0.40	0.3-3.0	☺	☺	☺																			
	CNMG120408-FW5	12.9	0.8	0.15-0.60	0.4-3.0	☺	☺	☺																		
CNMG120404-NFT	12.9	0.4	0.08-0.17	0.4-1.5																						
	CNMG120408-NFT	12.9	0.8	0.10-0.20	0.5-2.0																					
CNGG120404-NFT	12.9	0.4	0.06-0.15	0.3-1.5																						
	CNGG120408-NFT	12.9	0.8	0.08-0.18	0.4-2.0																					
CNMG120402-FM5	12.9	0.2	0.03-0.10	0.1-1.0																						
	CNMG120404-FM5	12.9	0.4	0.05-0.15	0.2-1.5				☺	☺	☺	☺														
	CNMG120408-FM5	12.9	0.8	0.07-0.20	0.4-1.5				☺	☺	☺	☺														
	CNMG120412-FM5	12.9	1.2	0.10-0.25	0.5-2.0																					
CNMG090304-FP5	9.67	0.4	0.04-0.20	0.1-1.5			☺	☺																		
	CNMG090308-FP5	9.67	0.8	0.08-0.25	0.2-2.0			☺	☺																	
	CNMG120402-FP5	12.9	0.2	0.04-0.12	0.1-0.5																					
	CNMG120404-FP5	12.9	0.4	0.04-0.20	0.1-1.5	☺	☺	☺																		
	CNMG120408-FP5	12.9	0.8	0.08-0.25	0.2-2.0	☺	☺	☺																		
	CNMG120412-FP5	12.9	1.2	0.10-0.25	0.5-2.5			☺	☺																	
CNMG120408-MW5	12.9	0.8	0.20-0.65	0.8-4.0		☺	☺	☺																		
	CNMG120412-MW5	12.9	1.2	0.25-0.70	1.5-4.0		☺	☺	☺																	
CNGG120402M-MN3	12.9	0.17	0.05-0.12	0.5-3.0																						
	CNGG120404M-MN3	12.9	0.37	0.08-0.30	0.8-4.0																					
	CNGG120408M-MN3	12.9	0.77	0.10-0.40	1.0-4.0																					
CNMG120404-MS3	12.9	0.4	0.12-0.25	0.6-3.0			☺																			
	CNMG120408-MS3	12.9	0.8	0.15-0.30	0.8-3.0			☺																		
	CNMG120412-MS3	12.9	1.2	0.15-0.40	1.0-3.5			☺																		
	CNMG190612-MS3	19.34	1.2	0.18-0.50	1.2-5.0																					

See the ISO 1832 designation key for dimensions  
 Ordering example for the grade WKP01G: CNMG120404-FW5 WKP01G

HC = Coated carbide  
 HE = Coated cermet  
 HW = Uncoated carbide



# Turning Insert – Negative rhombic 80°

## CNMG / CNGG / CNMA / CNMM

### Tiger-tec® Gold

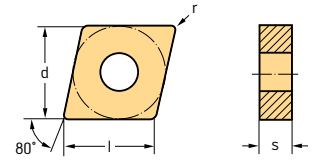

#### Indexable inserts

Designation	l mm	r mm	f mm	a <sub>p</sub> mm	P				M				K			N		S											
					HC				HE				HC				HC			HW		HC							
					WKP01G	WPP05G	WPP10G	WPP20G	WMP20S	WPP30G	WKP30S	WEP10C	WSM01	WSM10S	WMP20S	WSM20S	WSM30S	WKP01G	WKK10S	WKK20S	WKP30S	WNN10	WN10	WSM01	WSM10S	WSM20S	WSM30S	WS10	
CNGG120401-MS3	12.9	0.1	0.02-0.06	0.2-2.5									☺											☺					
CNGG120402-MS3	12.9	0.2	0.05-0.12	0.4-2.5									☺											☺					
CNGG120404-MS3	12.9	0.4	0.10-0.25	0.6-3.0									☺											☺					
CNGG120408-MS3	12.9	0.8	0.12-0.30	0.8-3.0									☺											☺					
CNMG120408-NMT	12.9	0.8	0.12-0.30	0.8-4.0											☺											☺	☺	☺	
CNMG120412-NMT	12.9	1.2	0.15-0.32	1.0-4.0											☺											☺	☺	☺	
CNMG120404-NMS	12.9	0.4	0.10-0.24	0.6-2.5									☺	☺	☺	☺								☺	☺	☺	☺	☺	
CNMG120408-NMS	12.9	0.8	0.13-0.32	0.8-3.5									☺	☺	☺	☺							☺	☺	☺	☺	☺		
CNMG120412-NMS	12.9	1.2	0.16-0.36	1.0-3.5									☺		☺									☺	☺	☺	☺		
CNMG090304-MP3	9.67	0.4	0.06-0.20	0.3-2.2			☺	☺																					
CNMG090308-MP3	9.67	0.8	0.10-0.28	0.6-3.0			☺	☺	☺																				
CNMG120404-MP3	12.9	0.4	0.08-0.22	0.3-2.5			☺	☺	☺																				
CNMG120408-MP3	12.9	0.8	0.12-0.32	0.6-3.2			☺	☺	☺	☺																			
CNMG120412-MP3	12.9	1.2	0.16-0.40	0.8-3.5			☺	☺	☺	☺																			
CNMG120404-MM5	12.9	0.4	0.10-0.20	0.5-3.0					☺					☺	☺	☺								☺	☺	☺	☺		
CNMG120408-MM5	12.9	0.8	0.15-0.32	0.8-3.0					☺					☺	☺	☺								☺	☺	☺	☺		
CNMG120412-MM5	12.9	1.2	0.15-0.35	0.8-3.5					☺					☺	☺	☺								☺	☺	☺	☺		
CNMG120416-MM5	12.9	1.6	0.15-0.40	1.0-4.0											☺	☺									☺	☺	☺		
CNMG160608-MM5	16.12	0.8	0.15-0.35	0.8-4.5					☺					☺	☺	☺								☺	☺	☺	☺		
CNMG160612-MM5	16.12	1.2	0.18-0.40	0.8-4.5					☺					☺	☺	☺								☺	☺	☺	☺		
CNMG160616-MM5	16.12	1.6	0.20-0.45	1.0-4.5											☺	☺									☺	☺	☺		
CNMG120404-MP5	12.9	0.4	0.16-0.25	0.5-4.0			☺	☺	☺																				
CNMG120408-MP5	12.9	0.8	0.18-0.40	0.6-5.0			☺	☺	☺	☺									☺										
CNMG120412-MP5	12.9	1.2	0.20-0.45	1.0-5.0			☺	☺	☺	☺																			
CNMG120416-MP5	12.9	1.6	0.25-0.50	1.2-5.0				☺	☺	☺																			
CNMG160608-MP5	16.12	0.8	0.25-0.40	0.8-7.0				☺	☺	☺	☺																		
CNMG160612-MP5	16.12	1.2	0.30-0.50	1.0-7.0			☺	☺	☺	☺																			
CNMG160616-MP5	16.12	1.6	0.35-0.55	1.2-7.0				☺	☺	☺	☺																		

See the ISO 1832 designation key for dimensions  
 Ordering example for the grade WKP01G: CNMG120404-FW5 WKP01G

HC = Coated carbide  
 HE = Coated cermet  
 HW = Uncoated carbide

#### WALTER SELECT

Optimum indexable insert for → Good = ☺ → Average = ☹ → Poor = ☹ machining conditions

☺ ☹ ☹ / \* = New addition to the product range

# Turning Insert – Negative rhombic 80°

## CNMG / CNGG / CNMA / CNMM

### Tiger-tec® Gold

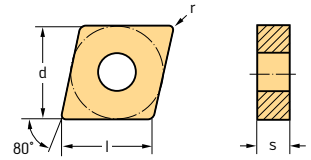

#### Indexable inserts

Designation	l mm	r mm	f mm	a <sub>p</sub> mm	P				M				K			N		S												
					HC				HE				HC				HC	HW	HC											
					WKP01G	WPP05G	WPP10G	WPP20G	WMP20S	WPP30G	WKP30S	WEP10C	WSM01	WSM10S	WMP20S	WSM20S	WSM30S	WKP01G	WKK10S	WKK20S	WKP30S	WNN10	WN10	WSM01	WSM10S	WSM20S	WSM30S	WS10		
CNMG120404-MU5	12.9	0.4	0.15-0.30	0.5-4.0		☺	☺	☺							☺	☺														
CNMG120408-MU5	12.9	0.8	0.15-0.40	0.6-5.0	☺	☺	☺	☺							☺	☺											☺			
CNMG120412-MU5	12.9	1.2	0.20-0.50	1.0-5.0	☺	☺	☺	☺							☺	☺											☺			
CNMG120416-MU5	12.9	1.6	0.25-0.55	1.2-5.0	☺	☺	☺	☺																						
CNMG160612-MU5	16.12	1.2	0.30-0.55	1.0-7.0	☺	☺	☺	☺							☺	☺											☺			
CNMG160616-MU5	16.12	1.6	0.35-0.55	1.2-7.0	☺	☺	☺	☺																						
CNMG090308-MK5	9.67	0.8	0.10-0.20	0.2-3.0																☺										
CNMG120404-MK5	12.9	0.4	0.16-0.25	0.6-5.0																☺	☺									
CNMG120408-MK5	12.9	0.8	0.25-0.50	0.8-5.0																☺	☺	☺								
CNMG120412-MK5	12.9	1.2	0.30-0.50	1.2-5.0																☺	☺	☺								
CNMG120416-MK5	12.9	1.6	0.35-0.50	1.5-5.0																☺	☺									
CNMG160608-MK5	16.12	0.8	0.25-0.50	0.8-7.0																☺	☺									
CNMG160612-MK5	16.12	1.2	0.30-0.60	1.2-7.0																☺	☺	☺								
CNMG160616-MK5	16.12	1.6	0.35-0.60	1.5-7.0																☺	☺									
CNMG190612-MK5	19.34	1.2	0.30-0.65	1.2-8.0																☺	☺									
CNMG190616-MK5	19.34	1.6	0.35-0.80	1.5-8.0																☺	☺									
CNMG120408-NRT	12.9	0.8	0.18-0.35	1.0-6.0																							☺		☺	
CNMG120412-NRT	12.9	1.2	0.20-0.40	1.2-6.0																								☺		☺
CNMG160612-NRT	16.12	1.2	0.28-0.55	1.5-7.5																									☺	☺
CNMG190616-NRT	19.34	1.6	0.35-0.70	2.0-9.0																									☺	☺
CNMG120408-NRS	12.9	0.8	0.16-0.35	1.0-4.0				☺					☺	☺	☺	☺	☺								☺	☺	☺	☺	☺	☺
CNMG120412-NRS	12.9	1.2	0.18-0.40	1.2-4.0				☺					☺	☺	☺	☺	☺								☺	☺	☺	☺	☺	☺
CNMG160612-NRS	16.12	1.2	0.21-0.45	1.2-6.5				☺					☺	☺	☺	☺	☺									☺	☺	☺	☺	☺
CNMG160616-NRS	16.12	1.6	0.23-0.50	1.5-6.5									☺	☺	☺	☺	☺									☺	☺			
CNMG190608-NRS	19.34	0.8	0.20-0.45	1.0-8.0									☺	☺	☺	☺	☺									☺	☺			
CNMG190612-NRS	19.34	1.2	0.23-0.50	1.2-8.5									☺	☺	☺	☺	☺									☺	☺			

See the ISO 1832 designation key for dimensions  
 Ordering example for the grade WKP01G: CNMG120404-FW5 WKP01G

HC = Coated carbide  
 HE = Coated cermet  
 HW = Uncoated carbide

# Turning Insert – Negative rhombic 80°

## CNMG / CNGG / CNMA / CNMM

### Tiger-tec® Gold

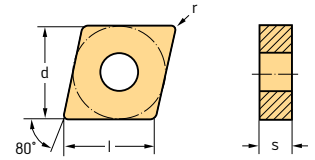

#### Indexable inserts

Designation	l mm	r mm	f mm	a <sub>p</sub> mm	P								M				K			N		S								
					HC								HE				HC				HC			HW		HC				
					WKP01G	WPP05G	WPP10G	WPP20G	WMP20S	WPP30G	WKP30S	WEP10C	WSM01	WSM10S	WMP20S	WSM20S	WSM30S	WKP01G	WKK10S	WKK20S	WKP30S	WNN10	WN10	WSM01	WSM10S	WSM20S	WSM30S	WS10		
CNMG120408-RM5	12.9	0.8	0.20-0.40	1.2-5.0		☺	☺	☺						☺	☺	☺	☺					☺	☺	☺						
CNMG120412-RM5	12.9	1.2	0.25-0.50	1.5-5.0		☺	☺	☺						☺	☺	☺	☺					☺	☺	☺						
CNMG120416-RM5	12.9	1.6	0.30-0.55	2.0-5.0											☺	☺	☺						☺	☺	☺					
CNMG160608-RM5	16.12	0.8	0.22-0.45	1.2-7.0										☺	☺	☺	☺					☺	☺	☺						
CNMG160612-RM5	16.12	1.2	0.25-0.60	1.5-7.0				☺						☺	☺	☺	☺					☺	☺	☺						
CNMG160616-RM5	16.12	1.6	0.30-0.65	2.0-7.0											☺	☺	☺						☺	☺	☺					
CNMG190612-RM5	19.34	1.2	0.25-0.60	1.5-8.0				☺						☺	☺	☺	☺					☺	☺	☺						
CNMG190616-RM5	19.34	1.6	0.30-0.80	2.0-8.0											☺	☺	☺						☺	☺	☺					
CNMG120408-RP5	12.9	0.8	0.20-0.40	0.8-6.0		☺	☺	☺	☺							☺														
CNMG120412-RP5	12.9	1.2	0.25-0.60	1.0-6.0		☺	☺	☺	☺							☺														
CNMG120416-RP5	12.9	1.6	0.35-0.70	1.6-6.0		☺	☺	☺	☺																					
CNMG160608-RP5	16.12	0.8	0.25-0.50	1.0-8.0			☺	☺	☺																					
CNMG160612-RP5	16.12	1.2	0.35-0.65	1.2-8.0		☺	☺	☺	☺																					
CNMG160616-RP5	16.12	1.6	0.40-0.70	1.6-8.0		☺	☺	☺	☺																					
CNMG160624-RP5	16.12	2.4	0.40-0.90	2.0-8.0			☺	☺																						
CNMG190608-RP5	19.34	0.8	0.25-0.50	1.0-10.0			☺	☺	☺	☺																				
CNMG190612-RP5	19.34	1.2	0.30-0.70	1.2-10.0		☺	☺	☺	☺																					
CNMG190616-RP5	19.34	1.6	0.35-0.80	1.6-10.0		☺	☺	☺	☺																					
CNMG190624-RP5	19.34	2.4	0.45-1.00	2.0-10.0			☺	☺																						
CNMG250924-RP5	25.79	2.4	0.45-1.20	2.0-12.0			☺																							
CNMG120408-RP7	12.9	0.8	0.18-0.40	0.8-5.0			☺	☺	☺	☺																				
CNMG120412-RP7	12.9	1.2	0.25-0.50	1.2-5.0		☺	☺	☺	☺	☺																				
CNMG120416-RP7	12.9	1.6	0.35-0.50	1.5-5.0			☺	☺	☺																					
CNMG160608-RP7	16.12	0.8	0.30-0.50	0.8-6.0			☺	☺	☺																					
CNMG160612-RP7	16.12	1.2	0.35-0.60	1.2-6.0		☺	☺	☺	☺	☺																				
CNMG160616-RP7	16.12	1.6	0.40-0.60	1.5-6.0		☺	☺	☺	☺	☺																				
CNMG190612-RP7	19.34	1.2	0.35-0.60	1.2-7.0			☺	☺	☺	☺	☺																			
CNMG190616-RP7	19.34	1.6	0.35-0.75	1.5-7.0		☺	☺	☺	☺	☺																				
CNMG250924-RP7	25.79	2.4	0.45-1.00	3.0-9.0			☺		☺																					

See the ISO 1832 designation key for dimensions  
 Ordering example for the grade WKP01G: CNMG120404-FW5 WKP01G

HC = Coated carbide  
 HE = Coated cermet  
 HW = Uncoated carbide

**WALTER SELECT** Optimum indexable insert for → Good = ☺ → Average = ☹ → Poor = ☹ machining conditions

☺ ☹ ☹ / \* = New addition to the product range

**Turning Insert – Negative rhombic 80°**  
**CNMG / CNGG / CNMA / CNMM**  
**Tiger-tec® Gold**

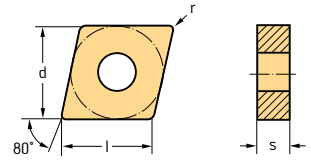

**Indexable inserts**

Designation	l mm	r mm	f mm	ap mm	P				M				K				N		S					
					HC				HE				HC				HC	HW	HC				HW	
					WKP01G	WPP05G	WPP10G	WPP20G	WMP20S	WPP30G	WKP30S	WEP10C	WSM01	WSM10S	WMP20S	WSM20S	WSM30S	WKP01G	WKK10S	WKK20S	WKP30S	WNN10	WN10	WSM01
CNMA120404-RK5	12.9	0.4	0.16–0.25	0.6–5.0											☺	☺								
CNMA120408-RK5	12.9	0.8	0.25–0.50	0.8–5.0										☺	☺	☺								
CNMA120412-RK5	12.9	1.2	0.30–0.50	1.2–5.0											☺	☺								
CNMA120416-RK5	12.9	1.6	0.35–0.70	1.5–5.0											☺	☺								
CNMA160612-RK5	16.12	1.2	0.35–0.70	1.2–7.0											☺	☺								
CNMA160616-RK5	16.12	1.6	0.35–0.80	1.5–7.0											☺	☺								
CNMA190612-RK5	19.34	1.2	0.30–0.65	1.2–8.0												☺								
CNMA190616-RK5	19.34	1.6	0.35–0.80	1.5–8.0												☺								
CNMA190624-RK5	19.34	2.4	0.40–0.90	2.5–8.0												☺								
CNMA120408-RK7	12.9	0.8	0.25–0.50	0.8–5.0											☺	☺								
CNMA120412-RK7	12.9	1.2	0.30–0.50	1.2–5.0											☺	☺								
CNMA120416-RK7	12.9	1.6	0.35–0.70	1.5–5.0											☺	☺								
CNMA160612-RK7	16.12	1.2	0.35–0.70	1.2–7.0											☺	☺								
CNMA160616-RK7	16.12	1.6	0.35–0.80	1.5–7.0											☺	☺								
CNMA190616-RK7	19.34	1.6	0.35–0.80	1.5–8.0											☺	☺								
CNMM120408-HU3	12.9	0.8	0.30–0.50	0.8–7.0		☺	☺	☺	☺															
CNMM120412-HU3	12.9	1.2	0.35–0.70	1.2–7.0	☺	☺	☺	☺	☺															
CNMM120416-HU3	12.9	1.6	0.40–0.80	1.6–7.0		☺	☺	☺	☺															
CNMM160612-HU3	16.12	1.2	0.35–0.70	1.2–9.0	☺	☺	☺	☺	☺															
CNMM160616-HU3	16.12	1.6	0.40–0.90	1.6–9.0	☺	☺	☺	☺	☺															
CNMM160624-HU3	16.12	2.4	0.45–1.00	2.4–9.0		☺	☺	☺	☺															
CNMM190612-HU3	19.34	1.2	0.35–0.70	1.2–10.0		☺	☺	☺	☺															
CNMM190616-HU3	19.34	1.6	0.40–0.90	1.6–10.0		☺	☺	☺	☺															
CNMM190624-HU3	19.34	2.4	0.45–1.10	2.4–10.0			☺	☺	☺															
CNMM250924-HU3	25.79	2.4	0.45–1.20	2.4–12.0			☺	☺	☺															

See the ISO 1832 designation key for dimensions  
 Ordering example for the grade WKP01G: CNMG120404-FW5 WKP01G

HC = Coated carbide  
 HE = Coated cermet  
 HW = Uncoated carbide

# Turning Insert – Negative rhombic 80°

## CNMG / CNGG / CNMA / CNMM

### Tiger-tec® Gold

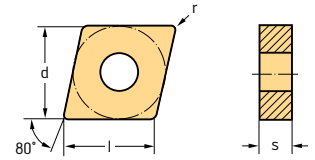

#### Indexable inserts

Designation	l mm	r mm	f mm	a <sub>p</sub> mm	P				M				K			N		S											
					HC				HE				HC				HC			HW		HC							
					WKP01G	WPP05G	WPP10G	WPP20G	WMP20S	WPP30G	WKP30S	WEP10C	WSM01	WSM10S	WMP20S	WSM20S	WSM30S	WKP01G	WKK10S	WKK20S	WKP30S	WNN10	WN10	WSM01	WSM10S	WSM20S	WSM30S	WS10	
CNMM120408-HU5	12.9	0.8	0.25-0.55	1.0-7.0		☺	☺	☺							☺	☺	☺											☺	☺
CNMM120412-HU5	12.9	1.2	0.30-0.70	1.5-7.0		☺	☺	☺							☺	☺	☺											☺	☺
CNMM160612-HU5	16.12	1.2	0.35-0.70	1.5-9.0		☺	☺	☺							☺	☺	☺											☺	☺
CNMM160616-HU5	16.12	1.6	0.40-0.80	2.0-9.0		☺	☺									☺												☺	☺
CNMM190612-HU5	19.34	1.2	0.35-0.70	1.5-10.0		☺	☺									☺												☺	☺
CNMM190616-HU5	19.34	1.6	0.40-0.90	2.0-10.0		☺	☺									☺												☺	☺
CNMM190624-HU5	19.34	2.4	0.45-1.00	2.0-10.0		☺	☺																						
CNMM120412-HU7	12.9	1.2	0.40-0.80	1.5-8.0		☺	☺																						
CNMM160612-HU7	16.12	1.2	0.50-0.90	2.0-10.0		☺	☺		☺																				
CNMM160616-HU7	16.12	1.6	0.50-1.10	2.0-10.0		☺	☺																						
CNMM160624-HU7	16.12	2.4	0.50-1.30	2.0-10.0		☺	☺																						
CNMM190612-HU7	19.34	1.2	0.50-0.90	2.0-13.0		☺	☺		☺																				
CNMM190616-HU7	19.34	1.6	0.50-1.10	2.0-13.0		☺	☺		☺																				
CNMM190624-HU7	19.34	2.4	0.60-1.60	3.0-13.0		☺	☺		☺																				
CNMM250924-HU7	25.79	2.4	0.60-1.60	3.0-17.0					☺	☺																			

See the ISO 1832 designation key for dimensions  
 Ordering example for the grade WKP01G: CNMG120404-FW5 WKP01G

HC = Coated carbide  
 HE = Coated cermet  
 HW = Uncoated carbide

# Turning Insert – Negative rhombic 55°

## DNMG / DNGG / DNMA / DNMM

### Tiger-tec® Gold

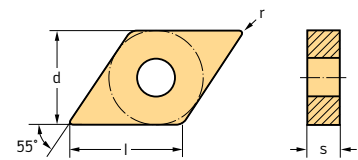

#### Indexable inserts

Designation	l mm	r mm	f mm	ap mm	Material																			
					P						M				K		N		S					
					HC						HC				HC		HW		HC					
	WKP01G	WPP05G	WPP10G	WPP20G	WMP20S	WPP30G	WEP10C	WSM01	WSM10S	WMP20S	WSM20S	WSM30S	WKP01G	WKK10S	WKK20S	WNN10	WN10	WSM01	WSM10S	WSM20S	WSM30S	WS10		
DNMG110404-FW5	11.63	0.4	0.10–0.35	0.3–2.0	☺	☺	☺						☺											
	DNMG110408-FW5	11.63	0.8	0.15–0.50	0.4–2.0	☺	☺	☺						☺										
	DNMG150404-FW5	15.5	0.4	0.10–0.40	0.3–3.0		☺	☺						☺										
	DNMG150408-FW5	15.5	0.8	0.15–0.50	0.4–3.0	☺	☺	☺						☺										
	DNMG150604-FW5	15.5	0.4	0.10–0.40	0.3–3.0	☺	☺	☺						☺										
	DNMG150608-FW5	15.5	0.8	0.15–0.50	0.4–3.0	☺	☺	☺						☺										
DNMG150404-NFT	15.5	0.4	0.06–0.16	0.4–1.5																				
	DNMG150604-NFT	15.5	0.4	0.06–0.16	0.4–1.5																			
	DNMG150608-NFT	15.5	0.8	0.08–0.19	0.5–2.0																		☺	
DNGG150604-NFT	15.5	0.4	0.05–0.14	0.2–1.5																			☺	
	DNGG150608-NFT	15.5	0.8	0.07–0.17	0.3–2.0																		☺	
DNMG110404-FM5	11.63	0.4	0.05–0.15	0.2–1.0																				
	DNMG110408-FM5	11.63	0.8	0.07–0.20	0.4–1.5																			
	DNMG150404-FM5	15.5	0.4	0.05–0.15	0.2–1.5																			
	DNMG150408-FM5	15.5	0.8	0.07–0.20	0.4–1.5																			
	DNMG150602-FM5	15.5	0.2	0.03–0.10	0.1–1.0																			
	DNMG150604-FM5	15.5	0.4	0.05–0.15	0.2–1.5																			
	DNMG150608-FM5	15.5	0.8	0.07–0.20	0.4–1.5																			
DNMG110402-FP5	11.63	0.2	0.04–0.12	0.1–0.5																				
	DNMG110404-FP5	11.63	0.4	0.04–0.20	0.1–1.5	☺	☺	☺						☺										
	DNMG110408-FP5	11.63	0.8	0.08–0.25	0.2–2.0	☺	☺	☺						☺										
	DNMG110412-FP5	11.63	1.2	0.10–0.25	0.5–2.5																			
	DNMG150404-FP5	15.5	0.4	0.05–0.20	0.1–1.5	☺	☺	☺						☺										
	DNMG150408-FP5	15.5	0.8	0.08–0.25	0.2–2.0	☺	☺	☺						☺										
	DNMG150412-FP5	15.5	1.2	0.10–0.25	0.5–2.5																			
	DNMG150604-FP5	15.5	0.4	0.05–0.20	0.1–1.5	☺	☺	☺						☺										
	DNMG150608-FP5	15.5	0.8	0.08–0.25	0.2–2.0	☺	☺	☺						☺										
	DNMG150612-FP5	15.5	1.2	0.10–0.25	0.5–2.5	☺	☺	☺						☺										
DNMG110408-MW5	11.63	0.8	0.15–0.50	0.8–3.0																				
	DNMG110412-MW5	11.63	1.2	0.20–0.60	1.5–3.0																			
	DNMG150408-MW5	15.5	0.8	0.15–0.55	0.8–4.0																			
	DNMG150412-MW5	15.5	1.2	0.20–0.65	1.5–4.0																			
	DNMG150608-MW5	15.5	0.8	0.15–0.55	1.5–4.0																			
DNMG150612-MW5	15.5	1.2	0.20–0.65	1.5–4.0																				
DNGG110402M-MN3	11.63	0.17	0.05–0.12	0.5–2.0																				
	DNGG110404M-MN3	11.63	0.37	0.08–0.30	0.6–3.0																			
DNMG110408-MS3	11.63	0.8	0.12–0.30	0.8–2.5																				
	DNMG150404-MS3	15.5	0.4	0.12–0.25	0.6–2.5																			
	DNMG150408-MS3	15.5	0.8	0.15–0.30	0.8–2.5																			
	DNMG150604-MS3	15.5	0.4	0.12–0.25	0.6–2.5																			
	DNMG150608-MS3	15.5	0.8	0.15–0.30	0.8–2.5																			

See the ISO 1832 designation key for dimensions  
 Ordering example for the grade WKP01G: DNMG110404-FW5 WKP01G

HC = Coated carbide  
 HE = Coated cermet  
 HW = Uncoated carbide

# Turning Insert – Negative rhombic 55°

## DNMG / DNGG / DNMA / DNMM

### Tiger-tec® Gold

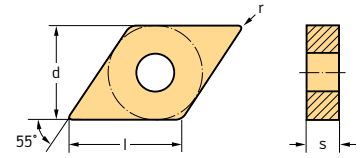

#### Indexable inserts

Designation	l mm	r mm	f mm	a <sub>p</sub> mm	Material																			
					P						M				K			N		S				
					HC						HC				HC			HW		HC				HW
	WKP01G	WPP05G	WPP10G	WPP20G	WMP20S	WPP30G	WEP10C	WSM01	WSM10S	WMP20S	WSM20S	WSM30S	WKP01G	WKK10S	WKK20S	WN10	WN10	WSM01	WSM10S	WSM20S	WSM30S	WS10		
	DNGG150402-MS3	15,5	0,2	0,05–0,12	0,4–2,0																			
	DNGG150404-MS3	15,5	0,4	0,10–0,25	0,6–2,5																			
	DNGG150408-MS3	15,5	0,8	0,12–0,30	0,8–2,5																			
	DNMG110404-NMT	11,63	0,4	0,08–0,22	0,4–2,5																			
	DNMG110408-NMT	11,63	0,8	0,12–0,28	0,6–3,2																			
	DNMG150408-NMT	15,5	0,8	0,12–0,28	0,6–4,0																			
	DNMG150608-NMT	15,5	0,8	0,12–0,28	0,6–4,0																			
	DNMG150612-NMT	15,5	1,2	0,15–0,30	0,8–4,0																			
	DNMG150404-NMS	15,5	0,4	0,09–0,22	0,6–2,5																			
	DNMG150408-NMS	15,5	0,8	0,11–0,30	0,8–3,5																			
	DNMG150604-NMS	15,5	0,4	0,09–0,22	0,6–2,5																			
	DNMG150608-NMS	15,5	0,8	0,11–0,30	0,8–3,5																			
	DNMG110404-MP3	11,63	0,4	0,08–0,22	0,3–2,2																			
	DNMG110408-MP3	11,63	0,8	0,12–0,32	0,6–3,0																			
	DNMG110412-MP3	11,63	1,2	0,16–0,40	0,8–3,2																			
	DNMG150404-MP3	15,5	0,4	0,08–0,22	0,3–2,5																			
	DNMG150408-MP3	15,5	0,8	0,12–0,32	0,6–3,2																			
	DNMG150412-MP3	15,5	1,2	0,16–0,40	0,8–3,5																			
	DNMG150604-MP3	15,5	0,4	0,08–0,22	0,3–2,5																			
	DNMG150608-MP3	15,5	0,8	0,12–0,32	0,6–3,2																			
	DNMG150612-MP3	15,5	1,2	0,16–0,40	0,8–3,5																			
		DNMG110404-MM5	11,63	0,4	0,10–0,18	0,5–2,0																		
DNMG110408-MM5		11,63	0,8	0,15–0,25	0,8–3,0																			
DNMG150404-MM5		15,5	0,4	0,10–0,18	0,5–2,5																			
DNMG150408-MM5		15,5	0,8	0,15–0,25	0,8–3,0																			
DNMG150412-MM5		15,5	1,2	0,18–0,30	0,8–3,0																			
DNMG150604-MM5		15,5	0,4	0,10–0,18	0,5–2,5																			
DNMG150608-MM5		15,5	0,8	0,15–0,25	0,8–3,0																			
DNMG150612-MM5		15,5	1,2	0,18–0,30	0,8–3,0																			
		DNMG110404-MP5	11,63	0,4	0,16–0,25	0,5–4,0																		
	DNMG110408-MP5	11,63	0,8	0,18–0,35	0,6–4,0																			
	DNMG110412-MP5	11,63	1,2	0,20–0,40	1,0–4,0																			
	DNMG150404-MP5	15,5	0,4	0,16–0,25	0,5–4,0																			
	DNMG150408-MP5	15,5	0,8	0,18–0,35	0,6–5,0																			
	DNMG150412-MP5	15,5	1,2	0,20–0,40	1,0–5,0																			
	DNMG150604-MP5	15,5	0,4	0,16–0,25	0,5–4,0																			
	DNMG150608-MP5	15,5	0,8	0,18–0,35	0,6–5,0																			
	DNMG150612-MP5	15,5	1,2	0,20–0,40	1,0–5,0																			
	DNMG150616-MP5	15,5	1,6	0,25–0,45	1,2–5,0																			
	DNMG110408-MU5	11,63	0,8	0,18–0,35	0,6–4,0																			
	DNMG150408-MU5	15,5	0,8	0,18–0,35	0,6–5,0																			
	DNMG150608-MU5	15,5	0,8	0,18–0,35	0,6–5,0																			
	DNMG150612-MU5	15,5	1,2	0,20–0,45	1,0–5,0																			
DNMG150616-MU5	15,5	1,6	0,25–0,50	1,2–5,0																				

See the ISO 1832 designation key for dimensions  
 Ordering example for the grade WKP01G: DNMG110404-FW5 WKP01G

HC = Coated carbide  
 HE = Coated cermet  
 HW = Uncoated carbide

**WALTER SELECT** Optimum indexable insert for → Good = ☺ → Average = ☹ → Poor = ☹ machining conditions

☺ ☹ ☹ / \* = New addition to the product range







# Turning Insert – Negative round

## RNMG / RNMA

### Tiger-tec® Gold

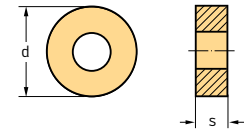

#### Indexable inserts

Designation	d mm	f mm	a <sub>p</sub> mm	P	K	S
				HC	HC	HW
				WPP20G	WKK20S	WS10
RNMG120400-RP5	12,7	0,20–0,60	1,2–5,0	☺	☺	☺
RNMA120400-RK5	12,7	0,15–0,60	1,2–4,0	☺		

See the ISO 1832 designation key for dimensions  
 Ordering example for the grade WPP20G: RNMG120400-RP5 WPP20G

HC = Coated carbide  
 HW = Uncoated carbide

# Turning Insert – Negative square

## SNMG / SNMA / SNMM

### Tiger-tec® Gold

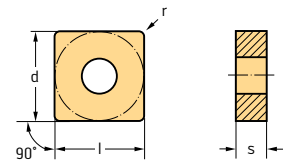

#### Indexable inserts

Designation	r mm	f mm	a <sub>p</sub> mm	P						M					K		S			
				HC						HC					HC		HC			
				WPP05G	WPP10G	WPP20G	WMPP20S	WPP30G	WKP30S	WSM01	WSM10S	WMPP20S	WSM20S	WSM30S	WKK10S	WKK20S	WSM01	WSM10S	WSM20S	WSM30S
SNMG120404-FM5	0,4	0,05–0,15	0,2–1,5																	
SNMG120408-FM5	0,8	0,07–0,20	0,4–1,5																	
SNMG120412-FM5	1,2	0,10–0,25	0,5–2,0				☺													
SNMG090308-FP5	0,8	0,06–0,20	0,2–1,5	☺	☺															
SNMG120404-FP5	0,4	0,04–0,22	0,1–1,8	☺	☺															
SNMG120408-FP5	0,8	0,08–0,25	0,2–2,0	☺	☺															
SNMG120412-FP5	1,2	0,10–0,25	0,5–2,5			☺														
SNMG090308-MP3	0,8	0,10–0,32	0,6–3,0	☺	☺															
SNMG120404-MP3	0,4	0,08–0,25	0,3–2,5	☺	☺															
SNMG120408-MP3	0,8	0,12–0,35	0,6–3,2	☺	☺		☺													
SNMG120412-MP3	1,2	0,16–0,40	0,8–3,5	☺	☺															
SNMG120404-MM5	0,4	0,10–0,18	0,5–2,0							☺	☺						☺	☺		
SNMG120408-MM5	0,8	0,15–0,25	0,8–3,0				☺			☺	☺	☺					☺	☺		
SNMG120412-MM5	1,2	0,18–0,30	0,8–3,5				☺			☺	☺	☺					☺	☺		

See the ISO 1832 designation key for dimensions  
 Ordering example for the grade WSM10S: SNMG120404-FM5 WSM10S

HC = Coated carbide  
 HW = Uncoated carbide

**WALTER SELECT** Optimum indexable insert for → Good = ☺ → Average = ☹ → Poor = ☹ machining conditions

☺ ☹ ☹ / \* = New addition to the product range

# Turning Insert – Negative square SNMG / SNMA / SNMM Tiger-tec® Gold

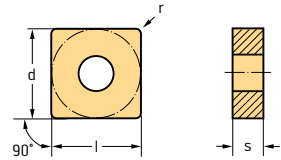

## Indexable inserts

Designation	r mm	f mm	ap mm	P						M					K		S			HW	
				HC						HC					HC		HC				
				WPP05G	WPP10G	WPP20G	WMP20S	WPP30G	WKP30S	WSM01	WSM10S	WMP20S	WSM20S	WSM30S	WKK10S	WKK20S	WSM01	WSM10S	WSM20S		WSM30S
SNMG090308-MP5	0.8	0.14–0.32	0.6–3.0																		
SNMG120408-MP5	0.8	0.18–0.40	0.6–5.0																		
SNMG120412-MP5	1.2	0.20–0.45	1.0–5.0																		
SNMG120416-MP5	1.6	0.25–0.50	1.2–5.0																		
SNMG150608-MP5	0.8	0.25–0.50	0.8–8.0																		
SNMG150612-MP5	1.2	0.30–0.50	1.0–8.0																		
SNMG150616-MP5	1.6	0.35–0.55	1.2–8.0																		
SNMG120408-MU5	0.8	0.18–0.45	0.6–5.0																		
SNMG090308-MK5	0.8	0.10–0.20	0.2–3.0																		
SNMG120408-MK5	0.8	0.25–0.50	0.8–5.0																		
SNMG120412-MK5	1.2	0.30–0.50	1.2–5.0																		
SNMG120416-MK5	1.6	0.35–0.50	1.5–5.0																		
SNMG150612-MK5	1.2	0.30–0.60	1.2–7.0																		
SNMG150616-MK5	1.6	0.35–0.60	1.5–7.0																		
SNMG190612-MK5	1.2	0.30–0.65	1.2–8.0																		
SNMG190616-MK5	1.6	0.35–0.80	1.5–8.0																		
SNMG120408-NMS	0.8	0.12–0.35	0.8–3.5																		
SNMG120412-NMS	1.2	0.15–0.40	0.8–3.5																		
SNMG120416-NMS	1.6	0.18–0.45	1.0–3.5																		
SNMG120412-NRT	1.2	0.25–0.50	0.8–6.0																		
SNMG150612-NRT	1.2	0.30–0.60	1.0–7.5																		
SNMG190616-NRT	1.6	0.40–0.80	1.5–9.0																		
SNMG120408-NRS	0.8	0.20–0.40	0.8–5.0																		
SNMG120412-NRS	1.2	0.22–0.45	1.0–5.0																		
SNMG150616-NRS	1.6	0.24–0.55	1.2–7.0																		
SNMG190612-NRS	1.2	0.24–0.55	1.0–9.0																		
SNMG190616-NRS	1.6	0.27–0.60	1.2–9.0																		
SNMG120408-RM5	0.8	0.20–0.40	1.2–5.0																		
SNMG120412-RM5	1.2	0.25–0.50	1.5–5.0																		
SNMG120416-RM5	1.6	0.30–0.55	2.0–5.0																		
SNMG150612-RM5	1.2	0.25–0.60	1.5–7.0																		
SNMG150616-RM5	1.6	0.30–0.55	2.0–7.0																		
SNMG190612-RM5	1.2	0.25–0.60	1.5–8.0																		
SNMG190616-RM5	1.6	0.30–0.80	2.0–8.0																		

See the ISO 1832 designation key for dimensions  
Ordering example for the grade WSM10S: SNMG120404-FM5 WSM10S

HC = Coated carbide  
HW = Uncoated carbide

# Turning Insert – Negative square

## SNMG / SNMA / SNMM

### Tiger-tec® Gold

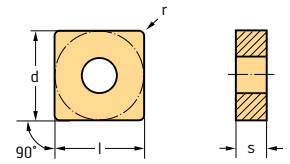

#### Indexable inserts

Designation	r mm	f mm	a <sub>p</sub> mm	P						M				K		S			
				HC						HC				HC		HC			
				WPP05G	WPP10G	WPP20G	WMP20S	WPP30G	WKP30S	WSM01	WSM10S	WMP20S	WSM20S	WSM30S	WKK10S	WKK20S	WSM01	WSM10S	WSM20S
SNMG120408-RP5	0.8	0.20-0.55	0.8-6.0	☺	☺	☺	☺												
SNMG120412-RP5	1.2	0.25-0.65	1.0-6.0	☺	☺	☺	☺												
SNMG120416-RP5	1.6	0.35-0.75	1.6-6.0	☺	☺	☺	☺												
SNMG150612-RP5	1.2	0.25-0.70	1.2-8.0	☺	☺	☺	☺												
SNMG150616-RP5	1.6	0.35-0.80	1.6-8.0	☺	☺	☺	☺												
SNMG190612-RP5	1.2	0.30-0.70	1.2-10.0	☺	☺	☺	☺												
SNMG190616-RP5	1.6	0.35-0.80	1.6-10.0	☺	☺	☺	☺												
SNMG190624-RP5	2.4	0.44-1.20	2.0-10.0		☺	☺	☺												
SNMG250924-RP5	2.4	0.55-1.20	2.5-12.0		☺	☺	☺												
SNMG120408-RP7	0.8	0.25-0.45	0.8-5.0			☺	☺												
SNMG120412-RP7	1.2	0.30-0.50	1.2-5.0			☺	☺												
SNMG120416-RP7	1.6	0.35-0.60	1.5-5.0		☺	☺	☺												
SNMG150612-RP7	1.2	0.35-0.60	1.2-6.0		☺	☺	☺												
SNMG150616-RP7	1.6	0.40-0.70	1.5-6.0		☺	☺	☺	☺											
SNMG190612-RP7	1.2	0.35-0.60	1.2-7.0			☺	☺												
SNMG190616-RP7	1.6	0.40-0.70	1.5-7.0		☺	☺	☺	☺											
SNMG190624-RP7	2.4	0.40-0.80	2.5-7.0			☺	☺												
SNMG250924-RP7	2.4	0.55-1.00	3.0-10.0			☺	☺												
SNMA090308-RK5	0.8	0.20-0.45	0.6-4.0										☺	☺					
SNMA120408-RK5	0.8	0.25-0.50	0.8-5.0										☺	☺					
SNMA120412-RK5	1.2	0.30-0.60	1.2-5.0										☺	☺					
SNMA120416-RK5	1.6	0.35-0.70	1.5-5.0										☺	☺					
SNMA150612-RK5	1.2	0.30-0.65	1.2-7.0										☺	☺					
SNMA150616-RK5	1.6	0.35-0.80	1.5-7.0										☺	☺					
SNMA190616-RK5	1.6	0.35-0.80	1.5-8.0										☺	☺					
SNMA190624-RK5	2.4	0.40-0.90	2.5-8.0										☺	☺					
SNMA120412-RK7	1.2	0.30-0.60	1.2-5.0										☺	☺					
SNMA120416-RK7	1.6	0.35-0.70	1.5-5.0										☺	☺					
SNMA150616-RK7	1.6	0.35-0.80	1.5-7.0										☺	☺					
SNMA190616-RK7	1.6	0.35-0.80	1.5-8.0										☺	☺					
SNMM120408-HU3	0.8	0.30-0.50	0.8-7.0			☺	☺	☺											
SNMM120412-HU3	1.2	0.35-0.70	1.2-7.0			☺	☺	☺											
SNMM120416-HU3	1.6	0.40-0.90	1.6-7.0		☺	☺	☺	☺											
SNMM150612-HU3	1.2	0.35-0.75	1.2-9.0			☺	☺	☺											
SNMM150616-HU3	1.6	0.40-0.90	1.6-9.0		☺	☺	☺	☺											
SNMM150624-HU3	2.4	0.45-1.10	2.0-9.0			☺	☺	☺											
SNMM190612-HU3	1.2	0.35-0.75	1.2-10.0		☺	☺	☺	☺											
SNMM190616-HU3	1.6	0.40-1.00	1.6-10.0		☺	☺	☺	☺											
SNMM190624-HU3	2.4	0.45-1.20	2.0-10.0			☺	☺	☺											
SNMM250724-HU3	2.4	0.55-1.20	2.5-12.0			☺	☺	☺											
SNMM250916-HU3	1.6	0.45-1.00	1.6-12.0			☺	☺	☺											
SNMM250924-HU3	2.4	0.55-1.20	2.5-12.0			☺	☺	☺											

See the ISO 1832 designation key for dimensions  
 Ordering example for the grade WSM10S: SNMG120404-FM5 WSM10S

HC = Coated carbide  
 HW = Uncoated carbide

#### WALTER SELECT

Optimum indexable insert for → Good = ☺ → Average = ☹ → Poor = ☹ machining conditions

☺ ☹ ☹ / \* = New addition to the product range

ISO indexable inserts – Negative basic shape

## Turning Insert – Negative square

### SNMG / SNMA / SNMM

### Tiger-tec® Gold

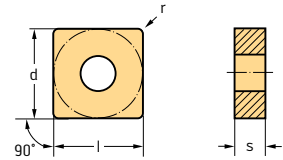

#### Indexable inserts

Designation	r mm	f mm	a <sub>p</sub> mm	P						M				K		S						
				HC						HC				HC		HC						
				WPP05G	WPP10G	WPP20G	WMP20S	WPP30G	WKP30S	WSM01	WSM10S	WMP20S	WSM20S	WSM30S	WKK10S	WKK20S	WSM01	WSM10S	WSM20S	WSM30S	WS10	
SNMM120412-HU5	1.2	0.30–0.70	1.5–7.0			☹								☹							☹	
SNMM150612-HU5	1.2	0.35–0.70	1.5–9.0			☹								☹							☹	
SNMM190612-HU5	1.2	0.35–0.80	1.5–10.0			☹	☹					☹		☹							☹	
SNMM190616-HU5	1.6	0.40–1.00	2.0–10.0			☹								☹							☹	
SNMM190624-HU5	2.4	0.45–1.10	2.0–10.0			☹								☹							☹	
SNMM250924-HU5	2.4	0.50–1.20	2.5–12.0			☹								☹							☹	
SNMM150616-HU7	1.6	0.45–1.00	2.0–12.0	☹	☹	☹																
SNMM150624-HU7	2.4	0.50–1.40	2.5–12.0	☹	☹	☹																
SNMM190612-HU7	1.2	0.50–1.00	2.0–13.0			☹		☹														
SNMM190616-HU7	1.6	0.50–1.10	2.5–13.0			☹		☹														
SNMM190624-HU7	2.4	0.60–1.60	3.0–13.0	☹	☹	☹		☹														
SNMM250716-HU7	1.6	0.50–1.10	2.5–17.0			☹																
SNMM250724-HU7	2.4	0.60–1.60	3.0–17.0			☹		☹														
SNMM250924-HU7	2.4	0.60–1.60	3.0–17.0	☹	☹	☹		☹														

See the ISO 1832 designation key for dimensions

Ordering example for the grade WSM10S: SNMG120404-FM5 WSM10S

HC = Coated carbide  
HW = Uncoated carbide

## Turning Insert – Negative triangular 60°

### TNMG / TNMA / TNMM

### Tiger-tec® Gold

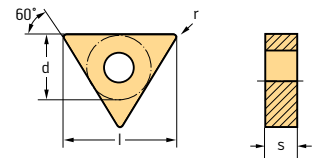

#### Indexable inserts

Designation	r mm	f mm	a <sub>p</sub> mm	P						M				K			S						
				HC						HC				HC			HC						
				WKP01G	WPP05G	WPP10G	WPP20G	WMP20S	WPP30G	WEP10C	WSM01	WSM10S	WMP20S	WSM20S	WSM30S	WKP01G	WKK10S	WKK20S	WSM01	WSM10S	WSM20S	WSM30S	
TNMG160404-FW5	0.4	0.10–0.40	0.3–3.0			☹	☹					☹									☹	☹	☹
TNMG160408-FW5	0.8	0.15–0.50	0.4–3.0			☹	☹					☹									☹	☹	☹
TNMG160404-FM5	0.4	0.05–0.15	0.2–1.0					☹				☹	☹	☹							☹	☹	☹
TNMG160408-FM5	0.8	0.07–0.20	0.4–1.5					☹				☹	☹	☹							☹	☹	☹
TNMG160412-FM5	1.2	0.10–0.25	0.5–2.0											☹								☹	☹

See the ISO 1832 designation key for dimensions

Ordering example for the grade WPP10G: TNMG160404-FW5 WPP10G

HC = Coated carbide  
HE = Coated cermet

# Turning Insert – Negative triangular 60°

## TNMG / TNMA / TNMM

### Tiger-tec® Gold

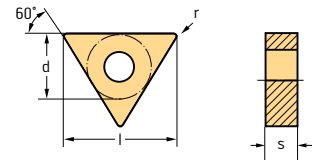

#### Indexable inserts

Designation	r mm	f mm	a <sub>p</sub> mm	P					M				K			S				
				HC					HE				HC				HC			
				WKP01G	WPP05G	WPP10G	WPP20G	WMP20S	WPP30G	WEP10C	WSM01	WSM10S	WMP20S	WSM20S	WSM30S	WKP01G	WKK10S	WKK20S	WSM01	WSM10S
TNMG110304-FP5	0,4	0,04–0,15	0,1–1,2			☺														
TNMG110308-FP5	0,8	0,08–0,20	0,2–1,5			☺														
TNMG160404-FP5	0,4	0,04–0,20	0,1–1,5	☺	☺	☺							☺							
TNMG160408-FP5	0,8	0,08–0,25	0,2–2,0	☺	☺	☺		☺					☺							
TNMG160412-FP5	1,2	0,10–0,25	0,5–2,5			☺	☺													
TNMG160404-MS3	0,4	0,12–0,25	0,6–3,0				☺												☺	
TNMG160408-MS3	0,8	0,15–0,30	0,8–3,0				☺	☺											☺	☺
TNMG220404-MS3	0,4	0,12–0,25	0,6–3,0				☺												☺	
TNMG220408-MS3	0,8	0,15–0,30	0,8–3,0				☺	☺											☺	☺
TNMG160408-MW5	0,8	0,15–0,55	0,8–4,0			☺	☺							☺	☺					
TNMG160412-MW5	1,2	0,20–0,65	1,5–4,0			☺	☺							☺	☺					
TNMG160404-NMS	0,4	0,09–0,22	0,6–2,5								☺	☺							☺	☺
TNMG160408-NMS	0,8	0,11–0,30	0,8–3,5								☺	☺	☺						☺	☺
TNMG110304-MP3	0,4	0,06–0,18	0,3–2,0			☺	☺													
TNMG110308-MP3	0,8	0,10–0,25	0,6–2,2			☺	☺													
TNMG160304-MP3	0,4	0,08–0,22	0,3–2,2			☺	☺													
TNMG160404-MP3	0,4	0,08–0,22	0,3–2,2			☺	☺													
TNMG160408-MP3	0,8	0,12–0,32	0,6–3,0			☺	☺	☺												
TNMG160412-MP3	1,2	0,16–0,40	0,8–3,2			☺	☺	☺												
TNMG220408-MP3	0,8	0,12–0,32	0,6–3,2			☺	☺													
TNMG220412-MP3	1,2	0,16–0,40	0,8–3,5			☺	☺													
TNMG160404-MM5	0,4	0,10–0,18	0,5–2,0					☺		☺	☺	☺							☺	☺
TNMG160408-MM5	0,8	0,15–0,25	0,8–3,0					☺		☺	☺	☺							☺	☺
TNMG160412-MM5	1,2	0,18–0,30	0,8–3,5					☺		☺	☺	☺							☺	☺
TNMG160416-MM5	1,6	0,20–0,35	1,0–4,0								☺									☺
TNMG160308-MP5	0,8	0,18–0,35	0,6–4,0				☺													
TNMG160404-MP5	0,4	0,16–0,25	0,5–4,0			☺	☺	☺	☺											
TNMG160408-MP5	0,8	0,18–0,35	0,6–4,0			☺	☺	☺	☺											
TNMG160412-MP5	1,2	0,20–0,40	1,0–4,0			☺	☺	☺	☺											
TNMG220404-MP5	0,4	0,16–0,25	0,7–4,0			☺	☺	☺	☺											
TNMG220408-MP5	0,8	0,18–0,35	0,8–5,0			☺	☺	☺	☺											
TNMG220412-MP5	1,2	0,20–0,40	1,0–5,0			☺	☺	☺	☺											
TNMG220416-MP5	1,6	0,25–0,45	1,2–5,0			☺	☺	☺	☺											
TNMG270608-MP5	0,8	0,25–0,45	0,8–7,0			☺	☺	☺	☺											
TNMG270612-MP5	1,2	0,30–0,50	1,0–7,0			☺	☺	☺	☺											
TNMG270616-MP5	1,6	0,35–0,55	1,2–7,0			☺	☺	☺	☺											
TNMG160404-MU5	0,4	0,15–0,30	0,5–4,0			☺	☺	☺	☺			☺	☺							☺
TNMG160408-MU5	0,8	0,18–0,35	0,6–4,0			☺	☺	☺	☺			☺	☺							☺
TNMG160412-MU5	1,2	0,20–0,45	1,0–4,0			☺	☺	☺	☺			☺								☺

See the ISO 1832 designation key for dimensions  
 Ordering example for the grade WPP10G: TNMG160404-FW5 WPP10G

HC = Coated carbide  
 HE = Coated cermet

## Turning Insert – Negative triangular 60°

### TNMG / TNMA / TNMM

### Tiger-tec® Gold

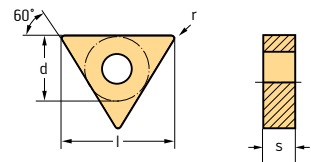

#### Indexable inserts

Designation	r mm	f mm	a <sub>p</sub> mm	P						M					K			S						
				HC			HE			HC					HC			HC						
				WKP01G	WPP05G	WPP10G	WPP20G	WMP20S	WPP30G	WEP10C	WSM01	WSM10S	WMP20S	WSM20S	WSM30S	WKP01G	WKK10S	WKK20S	WSM01	WSM10S	WSM20S	WSM30S		
TNMG160404-MK5	0,4	0,16–0,25	0,6–4,0													☺	☺							
TNMG160408-MK5	0,8	0,25–0,45	0,8–5,0													☺	☺	☺						
TNMG160412-MK5	1,2	0,30–0,45	1,2–5,0													☺	☺	☺						
TNMG160416-MK5	1,6	0,35–0,45	1,5–5,0													☺	☺	☺						
TNMG220408-MK5	0,8	0,25–0,45	1,0–6,0													☺	☺	☺						
TNMG220412-MK5	1,2	0,30–0,45	1,4–6,0													☺	☺	☺						
TNMG220416-MK5	1,6	0,35–0,45	1,6–6,0													☺	☺	☺						
TNMG270612-MK5	1,2	0,35–0,65	1,2–8,0													☺	☺	☺						
TNMG160412-NRS	1,2	0,25–0,50	1,5–4,5										☺										☺	
TNMG160408-RM5	0,8	0,20–0,40	1,2–4,0					☺				☺	☺	☺							☺	☺	☺	☺
TNMG160412-RM5	1,2	0,25–0,50	1,5–4,0					☺				☺	☺	☺							☺	☺	☺	☺
TNMG220408-RM5	0,8	0,20–0,40	1,2–4,0					☺				☺	☺	☺							☺	☺	☺	☺
TNMG220412-RM5	1,2	0,25–0,55	1,5–5,0					☺				☺	☺	☺							☺	☺	☺	☺
TNMG160408-RP5	0,8	0,20–0,40	0,8–5,0	☺	☺	☺		☺																
TNMG160412-RP5	1,2	0,25–0,55	1,0–5,0	☺	☺	☺		☺																
TNMG220408-RP5	0,8	0,20–0,45	0,8–7,0	☺	☺	☺		☺																
TNMG220412-RP5	1,2	0,25–0,60	1,0–7,0	☺	☺	☺		☺																
TNMG220416-RP5	1,6	0,35–0,70	1,6–7,0	☺	☺	☺		☺																
TNMG270612-RP5	1,2	0,30–0,70	1,6–10,0	☺	☺	☺		☺																
TNMG270616-RP5	1,6	0,35–0,80	2,0–10,0	☺	☺	☺		☺																
TNMG330924-RP5	2,4	0,45–1,20	2,5–13,0	☺	☺	☺		☺																
TNMG270616-RP7	1,6	0,35–0,75	1,5–9,0			☺		☺																
TNMG270624-RP7	2,4	0,55–1,00	3,0–9,0			☺		☺																
TNMA160404-RK5	0,4	0,16–0,25	0,6–5,0													☺	☺	☺						
TNMA160408-RK5	0,8	0,25–0,45	0,8–5,0													☺	☺	☺						
TNMA160412-RK5	1,2	0,30–0,50	1,2–5,0													☺	☺	☺						
TNMA220408-RK5	0,8	0,25–0,45	1,0–6,0													☺	☺	☺						
TNMA220412-RK5	1,2	0,30–0,55	1,4–6,0													☺	☺	☺						
TNMA220416-RK5	1,6	0,35–0,60	1,6–6,0													☺	☺	☺						
TNMA160408-RK7	0,8	0,25–0,45	0,8–5,0													☺	☺	☺						
TNMA160412-RK7	1,2	0,30–0,50	1,2–5,0													☺	☺	☺						
TNMM160408-HU3	0,8	0,30–0,45	0,8–6,0				☺																	
TNMM160412-HU3	1,2	0,35–0,50	1,2–6,0			☺	☺																	
TNMM220408-HU3	0,8	0,30–0,50	0,8–7,0			☺	☺		☺															
TNMM220412-HU3	1,2	0,35–0,60	1,2–7,0			☺	☺		☺															
TNMM220416-HU3	1,6	0,40–0,80	1,6–7,0			☺	☺		☺															
TNMM270612-HU3	1,2	0,35–0,65	1,2–8,0			☺	☺		☺															
TNMM270616-HU7	1,6	0,50–1,10	2,0–13,0			☺	☺		☺															

See the ISO 1832 designation key for dimensions  
Ordering example for the grade WPP10G: TNMG160404-FW5 WPP10G

HC = Coated carbide  
HE = Coated cermet

# Turning Insert – Negative rhombic 35°

## VNMG / VNGG / VNMA

### Tiger-tec® Gold

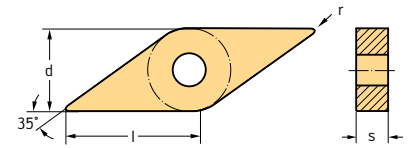

#### Indexable inserts

Designation	l mm	r mm	f mm	a <sub>p</sub> mm	P							M				K			N		S								
					HC							HE				HC				HC			HW		HC				
					WKP01G	WPP05G	WPP10G	WPP20G	WMP20S	WPP30G	WEP10C	WSM01	WSM10S	WMP20S	WSM20S	WSM30S	WKP01G	WKK10S	WKK20S	WNN10	WN10	WSM01	WSM10S	WSM20S	WSM30S	WS10			
VNMG160404-NFT	16.61	0.4	0.05–0.15	0.2–1.5																									
VNMG160408-NFT	16.61	0.8	0.07–0.18	0.3–2.0																									
VNGG160404-NFT	16.61	0.4	0.04–0.13	0.1–1.5																									
VNGG160408-NFT	16.61	0.8	0.06–0.16	0.2–2.0																									
VNGG160412-NFT	16.61	1.2	0.06–0.16	0.2–2.0																									
VNMG160402-FM5	16.61	0.2	0.03–0.10	0.1–1.0																									
VNMG160404-FM5	16.61	0.4	0.05–0.15	0.2–1.0																									
VNMG160408-FM5	16.61	0.8	0.07–0.20	0.4–1.5																									
VNMG160404-FP5	16.61	0.4	0.04–0.22	0.1–1.5	☺	☺	☺							☺															
VNMG160408-FP5	16.61	0.8	0.08–0.25	0.2–2.0	☺	☺	☺							☺															
VNMG160412-FP5	16.61	1.2	0.12–0.28	0.3–2.5		☺	☺																						
VNGG160402M-MN3	16.61	0.17	0.05–0.12	0.5–2.0														☺	☺										
VNGG160404M-MN3	16.61	0.37	0.08–0.30	0.6–3.0															☺	☺									
VNMG160404-MS3	16.61	0.4	0.10–0.20	0.6–2.5																☺	☺								
VNMG160408-MS3	16.61	0.8	0.12–0.25	0.8–2.5																☺	☺								
VNGG160401-MS3	16.61	0.1	0.02–0.06	0.2–2.0																	☺								
VNGG160402-MS3	16.61	0.2	0.05–0.12	0.4–2.0																	☺								
VNGG160404-MS3	16.61	0.4	0.10–0.20	0.6–2.0																	☺								
VNMG160404-NMS	16.61	0.4	0.08–0.16	0.5–1.5																		☺	☺						
VNMG160408-NMS	16.61	0.8	0.10–0.22	0.8–2.2																		☺	☺						
VNMG160404-MP3	16.61	0.4	0.08–0.22	0.3–2.2		☺	☺																						
VNMG160408-MP3	16.61	0.8	0.12–0.32	0.6–3.0		☺	☺		☺																				
VNMG160412-MP3	16.61	1.2	0.16–0.35	0.8–3.2		☺	☺																						
VNMG160404-MM5	16.61	0.4	0.10–0.18	0.5–2.0					☺													☺	☺	☺					
VNMG160408-MM5	16.61	0.8	0.15–0.25	0.8–3.0					☺													☺	☺	☺					
VNMG160404-MP5	16.61	0.4	0.10–0.18	0.5–2.0		☺	☺	☺		☺																			
VNMG160408-MP5	16.61	0.8	0.18–0.35	0.6–4.0		☺	☺	☺		☺																			
VNMG160412-MP5	16.61	1.2	0.20–0.40	0.8–4.0		☺	☺	☺		☺																			
VNMG220408-MP5	22.14	0.8	0.18–0.35	0.6–4.0		☺	☺																						
VNMG160404-MK5	16.61	0.4	0.16–0.25	0.6–4.0																	☺	☺							
VNMG160408-MK5	16.61	0.8	0.18–0.35	0.8–4.0																	☺	☺							
VNMG160412-MK5	16.61	1.2	0.20–0.35	1.0–4.0																	☺	☺							
VNMA160408-RK5	16.61	0.8	0.18–0.35	0.8–4.0																	☺	☺							
VNMA160412-RK5	16.61	1.2	0.20–0.40	1.0–4.0																	☺	☺							

See the ISO 1832 designation key for dimensions  
 Ordering example for the grade WS10: VNMG160404-NFT WS10

HC = Coated carbide  
 HE = Coated cermet  
 HW = Uncoated carbide



# Turning Insert – Negative Trigon 80°

## WNMG / WNGG / WNMA / WNMM

### Tiger-tec® Gold

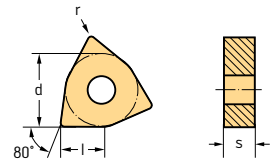

#### Indexable inserts

Designation	l mm	r mm	f mm	a <sub>p</sub> mm	P								M				K			N		S			
					WKP01G	WPP05G	WPP10G	WPP20G	WMP20S	WPP30G	WKP30S	WEP10C	WSM01	WSM10S	WMP20S	WSM20S	WSM30S	WKP01G	WKK10S	WKK20S	WNN10	WN10	WSM01	WSM10S	WSM20S
WNMG060404-FW5	6,52	0,4	0,10–0,35	0,3–2,0	☺	☺	☺	☺						☺	☺	☺					☺	☺	☺		
	WNMG060408-FW5	6,52	0,8	0,15–0,50	0,4–2,0		☺	☺							☺	☺					☺	☺	☺		
	WNMG080404-FW5	8,69	0,4	0,10–0,40	0,3–3,0	☺	☺	☺							☺	☺					☺	☺	☺		
	WNMG080408-FW5	8,69	0,8	0,15–0,60	0,4–3,0	☺	☺	☺							☺	☺					☺	☺	☺		
	WNMG080412-FW5	8,69	1,2	0,25–0,65	0,6–3,0	☺	☺	☺							☺						☺				
WNMG060404-FM5	6,52	0,4	0,05–0,15	0,2–1,0										☺	☺					☺	☺	☺			
	WNMG060408-FM5	6,52	0,8	0,07–0,20	0,4–1,5										☺	☺					☺	☺	☺		
	WNMG080404-FM5	8,69	0,4	0,05–0,15	0,2–1,5										☺	☺					☺	☺	☺		
	WNMG080408-FM5	8,69	0,8	0,07–0,20	0,4–1,5										☺	☺					☺	☺	☺		
	WNMG080412-FM5	8,69	1,2	0,10–0,25	0,5–2,0										☺						☺				
WNMG060404-FP5	6,52	0,4	0,04–0,20	0,1–1,5																					
	WNMG060408-FP5	6,52	0,8	0,08–0,25	0,2–2,0	☺	☺	☺							☺										
	WNMG080404-FP5	8,69	0,4	0,05–0,20	0,1–1,5	☺	☺	☺							☺										
	WNMG080408-FP5	8,69	0,8	0,08–0,25	0,2–2,0	☺	☺	☺							☺										
	WNMG080412-FP5	8,69	1,2	0,10–0,25	0,5–2,5										☺										
WNMG060408-MW5	6,52	0,8	0,15–0,50	0,8–3,0																					
	WNMG060412-MW5	6,52	1,2	0,20–0,60	1,5–3,0																				
	WNMG080408-MW5	8,69	0,8	0,20–0,65	0,8–4,0	☺	☺	☺	☺						☺	☺									
	WNMG080412-MW5	8,69	1,2	0,25–0,70	1,5–4,0	☺	☺	☺	☺						☺	☺									
WNGG080404M-MN3	8,69	0,37	0,08–0,30	0,8–4,0																					
	WNGG080408M-MN3	8,69	0,77	0,10–0,40	1,0–4,0																				
WNMG080404-MS3	8,69	0,4	0,12–0,25	0,6–3,0																					
	WNMG080408-MS3	8,69	0,8	0,15–0,30	0,8–3,0			☺							☺	☺					☺	☺	☺	☺	
WNMG080408-NMT	8,69	0,8	0,12–0,30	0,8–4,0																				☺	
WNMG060408-NMS	6,52	0,8	0,10–0,30	0,8–3,0																					
	WNMG080404-NMS	8,69	0,4	0,10–0,24	0,6–2,5										☺	☺					☺	☺	☺	☺	
	WNMG080408-NMS	8,69	0,8	0,13–0,32	0,8–3,5										☺	☺					☺	☺	☺	☺	
WNMG060404-MP3	6,52	0,4	0,08–0,22	0,3–2,2																					
	WNMG060408-MP3	6,52	0,8	0,12–0,32	0,6–3,0			☺	☺																
	WNMG060412-MP3	6,52	1,2	0,16–0,35	0,8–3,2				☺																
	WNMG080404-MP3	8,69	0,4	0,08–0,22	0,3–2,5				☺	☺															
	WNMG080408-MP3	8,69	0,8	0,12–0,32	0,6–3,2	☺	☺	☺	☺																
	WNMG080412-MP3	8,69	1,2	0,16–0,40	0,8–3,5	☺	☺	☺	☺																

See the ISO 1832 designation key for dimensions  
 Ordering example for the grade WKP01G: WNMG060404-FW5 WKP01G

HC = Coated carbide  
 HE = Coated cermet  
 HW = Uncoated carbide

**WALTER SELECT** Optimum indexable insert for → Good = ☺ → Average = ☹ → Poor = ☹☹ machining conditions



# Turning Insert – Negative Trigon 80°

## WNMG / WNGG / WNMA / WNMM

### Tiger-tec® Gold

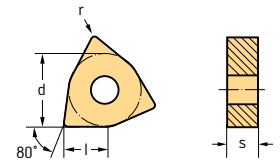

#### Indexable inserts

Designation	l mm	r mm	f mm	a <sub>p</sub> mm	P								M				K			N		S													
					HC								HE				HC				HC			HW		HC					HW				
					WKP01G	WPP05G	WPP10G	WPP20G	WMP20S	WPP30G	WKP30S	WEPT0C	WSM01	WSM10S	WMP20S	WSM20S	WSM30S	WKP01G	WKK10S	WKK20S	WNN10	WN10	WSM01	WSM10S	WSM20S	WSM30S	WS10								
	WNMG060404-MM5	6,52	0,4	0,10-0,18	0,5-2,0																														
	WNMG060408-MM5	6,52	0,8	0,15-0,25	0,8-2,5																														
	WNMG060412-MM5	6,52	1,2	0,18-0,30	0,8-3,0																														
	WNMG080404-MM5	8,69	0,4	0,10-0,20	0,5-3,0																														
	WNMG080408-MM5	8,69	0,8	0,15-0,32	0,8-3,0																														
	WNMG080412-MM5	8,69	1,2	0,15-0,35	0,8-3,5																														
	WNMG080416-MM5	8,69	1,6	0,15-0,40	1,0-4,0																														
	WNMG100608-MM5	10,86	0,8	0,18-0,40	0,8-4,5																														
WNMG100612-MM5	10,86	1,2	0,20-0,45	0,8-4,5																															
	WNMG060404-MP5	6,52	0,4	0,16-0,25	0,5-4,0			☺	☺	☺																									
	WNMG060408-MP5	6,52	0,8	0,18-0,35	0,6-4,0	☺	☺	☺	☺																										
	WNMG060412-MP5	6,52	1,2	0,20-0,40	1,0-4,0	☺	☺	☺	☺																										
	WNMG080404-MP5	8,69	0,4	0,16-0,25	0,5-4,0			☺	☺																										
	WNMG080408-MP5	8,69	0,8	0,18-0,40	0,6-5,0	☺	☺	☺	☺																										
	WNMG080412-MP5	8,69	1,2	0,20-0,45	1,0-5,0	☺	☺	☺	☺																										
	WNMG080416-MP5	8,69	1,6	0,25-0,50	1,2-5,0			☺	☺																										
	WNMG100608-MP5	10,86	0,8	0,25-0,40	0,8-7,0			☺	☺																										
WNMG100612-MP5	10,86	1,2	0,30-0,50	1,0-7,0			☺	☺																											
	WNMG060408-MU5	6,52	0,8	0,15-0,35	0,6-3,0			☺	☺	☺																									
	WNMG080404-MU5	8,69	0,4	0,15-0,30	0,5-4,0			☺	☺	☺																									
	WNMG080408-MU5	8,69	0,8	0,15-0,40	0,6-5,0	☺	☺	☺	☺																										
	WNMG080412-MU5	8,69	1,2	0,20-0,50	1,0-5,0	☺	☺	☺	☺																										
	WNMG080416-MU5	8,69	1,6	0,25-0,55	1,2-5,0	☺	☺	☺																											
	WNMG060404-MK5	6,52	0,4	0,16-0,25	0,6-4,0																														
	WNMG060408-MK5	6,52	0,8	0,20-0,40	0,8-4,0																														
	WNMG060412-MK5	6,52	1,2	0,16-0,45	0,6-4,0																														
	WNMG080404-MK5	8,69	0,4	0,16-0,25	0,6-5,0																														
	WNMG080408-MK5	8,69	0,8	0,20-0,45	1,2-5,0																														
	WNMG080412-MK5	8,69	1,2	0,22-0,50	1,5-5,0																														
	WNMG080416-MK5	8,69	1,6	0,25-0,55	2,0-5,0																														
	WNMG100608-MK5	10,86	0,8	0,25-0,50	0,8-7,0																														
	WNMG100612-MK5	10,86	1,2	0,30-0,60	1,2-7,0																														
	WNMG100616-MK5	10,86	1,6	0,35-0,60	1,5-7,0																														
	WNMG080408-NRS	8,69	0,8	0,16-0,35	1,0-4,0					☺																									
	WNMG080412-NRS	8,69	1,2	0,18-0,40	1,2-4,0					☺																									
	WNMG060408-RM5	6,52	0,8	0,20-0,40	1,2-3,5																														
	WNMG080408-RM5	8,69	0,8	0,20-0,40	1,2-4,5			☺	☺	☺																									
	WNMG080412-RM5	8,69	1,2	0,25-0,50	1,5-4,5				☺																										

See the ISO 1832 designation key for dimensions  
 Ordering example for the grade WKP01G: WNMG060404-FW5 WKP01G

HC = Coated carbide  
 HE = Coated cermet  
 HW = Uncoated carbide

# Turning Insert – Negative Trigon 80°

## WNMG / WNGG / WNMA / WNMM

### Tiger-tec® Gold

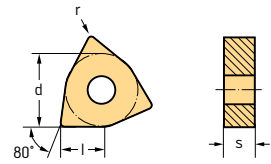

#### Indexable inserts

Designation	l mm	r mm	f mm	a <sub>p</sub> mm	P										M				K			N		S				
					HC					HE					HC				HC			HW		HC			HW	
					WKP01G	WPP05G	WPP10G	WPP20G	WMP20S	WPP30G	WKP30S	WEP10C	WSM01	WSM10S	WMP20S	WSM20S	WSM30S	WKP01G	WKK10S	WKK20S	WNN10	WN10	WSM01	WSM10S	WSM20S	WSM30S	WS10	
	WNMG060408-RP5	6,52	0,8	0,20–0,40	0,8–4,0		☺	☺	☺	☺	☺																	
	WNMG060412-RP5	6,52	1,2	0,25–0,50	1,0–4,0		☺	☺	☺	☺	☺																	
	WNMG080408-RP5	8,69	0,8	0,20–0,40	0,8–6,0		☺	☺	☺	☺	☺																	
	WNMG080412-RP5	8,69	1,2	0,25–0,60	1,0–6,0		☺	☺	☺	☺	☺																	
	WNMG080416-RP5	8,69	1,6	0,35–0,70	1,6–6,0		☺	☺	☺	☺	☺																	
	WNMG100612-RP5	10,86	1,2	0,35–0,65	1,2–8,0			☺	☺	☺	☺																	
WNMG100616-RP5	10,86	1,6	0,35–0,70	1,6–8,0			☺	☺	☺	☺																		
	WNMG080408-RP7	8,69	0,8	0,18–0,40	0,8–5,0			☺	☺	☺	☺	☺																
	WNMG080412-RP7	8,69	1,2	0,25–0,50	1,2–5,0			☺	☺	☺	☺	☺																
	WNMG100608-RP7	10,86	0,8	0,30–0,50	0,8–6,0				☺	☺	☺	☺																
	WNMG100612-RP7	10,86	1,2	0,35–0,60	1,2–6,0				☺	☺	☺	☺																
	WNMG100616-RP7	10,86	1,6	0,40–0,60	1,5–6,0				☺	☺	☺	☺																
	WNMA060404-RK5	6,52	0,4	0,16–0,25	0,6–4,0																							
WNMA060408-RK5	6,52	0,8	0,20–0,40	0,8–4,0																								
WNMA060412-RK5	6,52	1,2	0,22–0,50	1,2–4,0																								
WNMA080404-RK5	8,69	0,4	0,16–0,25	0,6–5,0																								
WNMA080408-RK5	8,69	0,8	0,20–0,45	1,2–5,0																								
WNMA080412-RK5	8,69	1,2	0,22–0,50	1,5–5,0																								
WNMA100612-RK5	10,86	1,2	0,25–0,60	1,5–6,0																								
WNMA100616-RK5	10,86	1,6	0,30–0,65	1,5–6,0																								
WNMA080408-RK7	8,69	0,8	0,20–0,45	1,2–5,0																								
WNMA080412-RK7	8,69	1,2	0,22–0,50	1,5–5,0																								
	WNMM080412-HU3	8,69	1,2	0,35–0,60	1,2–6,0				☺																			
	WNMM100612-HU3	10,86	1,2	0,35–0,70	1,2–8,0				☺	☺																		
	WNMM100616-HU3	10,86	1,6	0,40–0,90	1,6–8,0				☺	☺																		

See the ISO 1832 designation key for dimensions  
 Ordering example for the grade WKP01G: WNMG060404-FW5 WKP01G

HC = Coated carbide  
 HE = Coated cermet  
 HW = Uncoated carbide

# Turning Insert – Positive rhombic 80°

## CCMT / CCGT / CCMW

### Tiger-tec® Gold

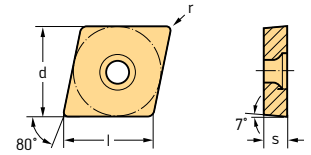

#### Indexable inserts

Designation	l mm	r mm	f mm	a <sub>p</sub> mm	P						M				K			N		S		
					HC						HC				HC			HC	HW	HC		
					WKP01G	WPP10G	WPP20G	WMP20S	WPP30G	WEP01C	WEP10C	WSM01	WSM10S	WMP20S	WSM20S	WSM30S	WKP01G	WKK10S	WKK20S	WN10	WN10	WSM01
CCMT060202-FW4	6,45	0,2	0,03–0,15	0,1–1,5			☺															
CCMT060204-FW4	6,45	0,4	0,05–0,30	0,2–2,0	☺	☺	☺						☺								☺	☺
CCMT060208-FW4	6,45	0,8	0,09–0,35	0,3–2,0	☺	☺	☺						☺								☺	☺
CCMT09T302-FW4	9,67	0,2	0,03–0,15	0,1–2,0			☺															
CCMT09T304-FW4	9,67	0,4	0,07–0,30	0,2–2,5	☺	☺	☺						☺								☺	☺
CCMT09T308-FW4	9,67	0,8	0,12–0,50	0,3–2,5	☺	☺	☺						☺								☺	☺
CCGT060202-FL2	6,45	0,2	0,04–0,10	0,1–1,0			☺															
CCGT060204-FL2	6,45	0,4	0,06–0,15	0,2–1,5			☺															
CCGT09T302-FL2	9,67	0,2	0,04–0,10	0,1–1,0			☺															
CCGT09T304-FL2	9,67	0,4	0,06–0,15	0,2–1,5			☺															
CCGT060201-FN2	6,45	0,1	0,02–0,06	0,1–1,5																		
CCGT060202-FN2	6,45	0,2	0,05–0,12	0,2–2,0																		
CCGT060204-FN2	6,45	0,4	0,08–0,25	0,2–2,5																		
CCGT09T301-FN2	9,67	0,1	0,02–0,06	0,1–1,5																		
CCGT09T302-FN2	9,67	0,2	0,05–0,12	0,2–2,0																		
CCGT09T304-FN2	9,67	0,4	0,08–0,25	0,2–2,5																		
CCGT09T308-FN2	9,67	0,8	0,10–0,30	0,3–3,0																		
CCGT120404-FN2	12,9	0,4	0,08–0,25	0,2–3,0																		
CCGT120408-FN2	12,9	0,8	0,10–0,30	0,3–3,5																		
CCGT060201-FM2	6,45	0,1	0,02–0,06	0,1–1,5																		
CCGT060202-FM2	6,45	0,2	0,05–0,12	0,2–2,0																		
CCGT060204-FM2	6,45	0,4	0,08–0,25	0,2–2,5																		
CCGT09T301-FM2	9,67	0,1	0,02–0,06	0,1–1,5																		
CCGT09T302-FM2	9,67	0,2	0,05–0,12	0,2–2,0																		
CCGT09T304-FM2	9,67	0,4	0,08–0,25	0,2–2,5																		
CCGT09T308-FM2	9,67	0,8	0,10–0,30	0,3–3,0																		
CCGT120404-FM2	12,9	0,4	0,08–0,25	0,2–3,0																		
CCGT120408-FM2	12,9	0,8	0,10–0,30	0,3–3,5																		
CCGT060201M-FP2	6,45	0,07	0,02–0,06	0,1–1,5																		
CCGT060202M-FP2	6,45	0,17	0,05–0,12	0,2–2,0																		
CCGT060204M-FP2	6,45	0,37	0,08–0,25	0,2–2,5																		
CCGT09T301M-FP2	9,67	0,07	0,02–0,06	0,1–1,5																		
CCGT09T302M-FP2	9,67	0,17	0,05–0,12	0,2–2,0																		
CCGT09T304M-FP2	9,67	0,37	0,08–0,25	0,2–2,5																		
CCGT09T308M-FP2	9,67	0,77	0,10–0,30	0,3–3,0																		
CCGT060202MR-FX4	6,45	0,17	0,02–0,10	0,1–1,5																		
CCGT060204MR-FX4	6,45	0,37	0,05–0,15	0,1–2,0																		
CCGT09T302MR-FX4	9,67	0,17	0,02–0,10	0,1–1,5																		
CCGT09T304MR-FX4	9,67	0,37	0,05–0,15	0,1–2,0																		
CCGT09T308MR-FX4	9,67	0,77	0,08–0,25	0,2–2,5																		
CCGT060202ML-FX4	6,45	0,17	0,02–0,10	0,1–1,5																		
CCGT060204ML-FX4	6,45	0,37	0,05–0,15	0,1–2,0																		
CCGT09T302ML-FX4	9,67	0,17	0,02–0,10	0,1–1,5																		
CCGT09T304ML-FX4	9,67	0,37	0,05–0,15	0,1–2,0																		
CCGT09T308ML-FX4	9,67	0,77	0,08–0,25	0,2–2,5																		

See the ISO 1832 designation key for dimensions  
 Ordering example for the grade WPP20G: CCMT060202-FW4 WPP20G

HC = Coated carbide  
 HE = Coated cermet  
 HW = Uncoated carbide

#### WALTER SELECT

Optimum indexable insert for → Good = ☺ → Average = ☹ → Poor = ☹ machining conditions

☺ ☹ ☹ / \* = New addition to the product range

# Turning Insert – Positive rhombic 80°

## CCMT / CCGT / CCMW

### Tiger-tec® Gold

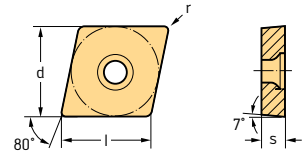

#### Indexable inserts

Designation	l mm	r mm	f mm	a <sub>p</sub> mm	P						M					K			N		S						
					HC						HC					HC			HC	HW	HC						
					WKP01G	WPP10G	WPP20G	WMP20S	WPP30G	WEP01C	WEP10C	WSM01	WSM10S	WMP20S	WSM20S	WSM30S	WKP01G	WKK10S	WKK20S	WN10	WN10	WSM01	WSM10S	WSM20S	WSM30S		
CCMT060202-FM4	6.45	0.2	0.04–0.12	0.1–1.0				☺					☺										☺	☺	☺	☺	
CCMT060204-FM4	6.45	0.4	0.05–0.16	0.1–1.5				☺					☺										☺	☺	☺	☺	
CCMT060208-FM4	6.45	0.8	0.08–0.20	0.1–1.5				☺					☺										☺	☺	☺	☺	
CCMT09T302-FM4	9.67	0.2	0.04–0.12	0.1–1.0				☺					☺										☺	☺	☺	☺	
CCMT09T304-FM4	9.67	0.4	0.05–0.16	0.1–1.5				☺					☺										☺	☺	☺	☺	
CCMT09T308-FM4	9.67	0.8	0.08–0.20	0.1–1.5				☺					☺										☺	☺	☺	☺	
CCMT120404-FM4	12.9	0.4	0.05–0.16	0.1–1.5				☺					☺										☺	☺	☺	☺	
CCMT120408-FM4	12.9	0.8	0.08–0.20	0.1–1.5				☺					☺										☺	☺	☺	☺	
CCMT060202-FP4	6.45	0.2	0.04–0.12	0.1–1.0	☺	☺	☺																				
CCMT060204-FP4	6.45	0.4	0.05–0.16	0.1–1.5	☺	☺	☺																				
CCMT060208-FP4	6.45	0.8	0.08–0.20	0.1–1.5	☺	☺	☺																				
CCMT09T302-FP4	9.67	0.2	0.04–0.12	0.1–1.0	☺	☺	☺																				
CCMT09T304-FP4	9.67	0.4	0.05–0.16	0.1–1.5	☺	☺	☺																				
CCMT09T308-FP4	9.67	0.8	0.08–0.20	0.1–1.5	☺	☺	☺																				
CCMT120404-FP4	12.9	0.4	0.05–0.16	0.1–1.5	☺	☺	☺																				
CCMT120408-FP4	12.9	0.8	0.08–0.20	0.1–1.5	☺	☺	☺																				
CCMT060204-FM6	6.45	0.4	0.08–0.25	0.3–1.6																						☺	☺
CCMT060208-FM6	6.45	0.8	0.12–0.30	0.5–1.6																						☺	☺
CCMT09T304-FM6	9.67	0.4	0.08–0.25	0.3–2.0																						☺	☺
CCMT09T308-FM6	9.67	0.8	0.12–0.32	0.5–2.0																						☺	☺
CCMT120408-FM6	12.9	0.8	0.12–0.32	0.5–2.5																						☺	☺
CCMT060204-FP6	6.45	0.4	0.06–0.18	0.3–2.0	☺	☺																					
CCMT060208-FP6	6.45	0.8	0.10–0.20	0.5–2.0	☺	☺																					
CCMT09T304-FP6	9.67	0.4	0.08–0.20	0.3–2.0	☺	☺																					
CCMT09T308-FP6	9.67	0.8	0.12–0.32	0.5–2.0	☺	☺																					
CCMT120404-FP6	12.9	0.4	0.10–0.25	0.3–2.5	☺	☺																					
CCMT120408-FP6	12.9	0.8	0.12–0.32	0.5–2.5	☺	☺																					
CCMT060204-FK6	6.45	0.4	0.06–0.18	0.3–2.0																						☺	☺
CCMT060208-FK6	6.45	0.8	0.10–0.20	0.5–2.0																						☺	☺
CCMT09T304-FK6	9.67	0.4	0.08–0.20	0.3–2.0																						☺	☺
CCMT09T308-FK6	9.67	0.8	0.10–0.25	0.5–2.0																						☺	☺
CCMT120404-FK6	12.9	0.4	0.10–0.25	0.3–2.5																						☺	☺
CCMT120408-FK6	12.9	0.8	0.12–0.32	0.5–2.5																						☺	☺
CCMT09T304-MW4	9.67	0.4	0.12–0.40	0.5–4.0	☺	☺																				☺	☺
CCMT09T308-MW4	9.67	0.8	0.15–0.50	0.7–4.0	☺	☺																				☺	☺
CCMT09T312-MW4	9.67	1.2	0.17–0.55	0.8–4.0	☺	☺																				☺	☺
CCMT120404-MW4	12.9	0.4	0.12–0.40	0.5–4.5	☺	☺																				☺	☺
CCMT120408-MW4	12.9	0.8	0.17–0.55	0.7–4.5	☺	☺																				☺	☺
CCMT120412-MW4	12.9	1.2	0.17–0.55	0.8–4.5	☺	☺																				☺	☺

See the ISO 1832 designation key for dimensions  
 Ordering example for the grade WPP20G: CCMT060202-FW4 WPP20G

HC = Coated carbide  
 HE = Coated cermet  
 HW = Uncoated carbide

# Turning Insert – Positive rhombic 80°

## CCMT / CCGT / CCMW

### Tiger-tec® Gold

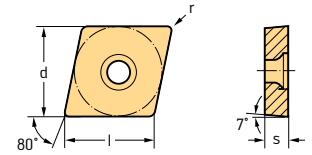

#### Indexable inserts

Designation	l mm	r mm	f mm	a <sub>p</sub> mm	P						M					K			N		S		
					HC			HE			HC					HC			HC	HW	HC		
					WKP01G	WPP10G	WPP20G	WMP20S	WPP30G	WEP01C	WEP10C	WSM01	WSM10S	WMP20S	WSM20S	WSM30S	WKP01G	WKK10S	WKK20S	WNN10	WN10	WSM01	WSM10S
CCGT060201-MN2	6,45	0,1	0,02-0,06	0,5-1,5																			
CCGT060202-MN2	6,45	0,2	0,05-0,12	0,5-2,0																			
CCGT060204-MN2	6,45	0,4	0,08-0,25	0,6-3,0																			
CCGT09T301-MN2	9,67	0,1	0,02-0,06	0,5-1,5																			
CCGT09T302-MN2	9,67	0,2	0,05-0,12	0,5-2,0																			
CCGT09T304-MN2	9,67	0,4	0,08-0,25	0,6-4,0																			
CCGT09T308-MN2	9,67	0,8	0,10-0,35	0,8-4,0																			
CCGT120402-MN2	12,9	0,2	0,05-0,12	0,5-2,0																			
CCGT120404-MN2	12,9	0,4	0,08-0,25	0,6-5,0																			
CCGT120408-MN2	12,9	0,8	0,10-0,35	0,8-5,0																			
CCMT060204-MM4	6,45	0,4	0,08-0,20	0,4-2,0																			
CCMT060208-MM4	6,45	0,8	0,12-0,25	0,5-2,0																			
CCMT09T304-MM4	9,67	0,4	0,08-0,25	0,4-3,0																			
CCMT09T308-MM4	9,67	0,8	0,12-0,32	0,5-3,0																			
CCMT120404-MM4	12,9	0,4	0,12-0,25	0,4-3,5																			
CCMT120408-MM4	12,9	0,8	0,12-0,32	0,5-3,5																			
CCGT060204-MM4	6,45	0,4	0,08-0,20	0,4-2,0																			
CCGT060208-MM4	6,45	0,8	0,12-0,25	0,5-2,0																			
CCGT09T304-MM4	9,67	0,4	0,08-0,25	0,4-3,0																			
CCGT09T308-MM4	9,67	0,8	0,12-0,32	0,5-3,0																			
CCGT120408-MM4	12,9	0,8	0,12-0,32	0,5-3,5																			
CCMT060204-MP4	6,45	0,4	0,08-0,20	0,4-2,0																			
CCMT060208-MP4	6,45	0,8	0,12-0,25	0,5-2,0																			
CCMT09T304-MP4	9,67	0,4	0,08-0,25	0,4-3,0																			
CCMT09T308-MP4	9,67	0,8	0,12-0,32	0,5-3,0																			
CCMT120404-MP4	12,9	0,4	0,12-0,25	0,4-3,5																			
CCMT120408-MP4	12,9	0,8	0,12-0,32	0,5-3,5																			
CCGT060204-MP4	6,45	0,4	0,08-0,20	0,4-2,0																			
CCGT09T304-MP4	9,67	0,4	0,08-0,25	0,4-3,0																			
CCGT09T308-MP4	9,67	0,8	0,12-0,32	0,5-3,0																			
CCGT120408-MP4	12,9	0,8	0,12-0,32	0,5-3,5																			
CCMT060204-MP6	6,45	0,4	0,10-0,20	0,4-2,5																			
CCMT090304-MP6	9,67	0,4	0,10-0,25	0,4-3,5																			
CCMT090308-MP6	9,67	0,8	0,15-0,32	0,6-3,5																			
CCMT09T304-MP6	9,67	0,4	0,08-0,25	0,4-3,0																			
CCMT09T308-MP6	9,67	0,8	0,12-0,32	0,5-3,0																			
CCMT120408-MP6	12,9	0,8	0,15-0,35	0,6-4,0																			
CCMT160508-MP6	16,12	0,8	0,15-0,40	0,8-4,0																			

See the ISO 1832 designation key for dimensions  
 Ordering example for the grade WPP20G: CCMT060202-FW4 WPP20G

HC = Coated carbide  
 HE = Coated cermet  
 HW = Uncoated carbide

#### WALTER SELECT

Optimum indexable insert for → Good = ☺ → Average = ☹ → Poor = ☹ machining conditions

☺ ☹ ☹ / \* = New addition to the product range

# Turning Insert – Positive rhombic 80°

## CCMT / CCGT / CCMW

### Tiger-tec® Gold

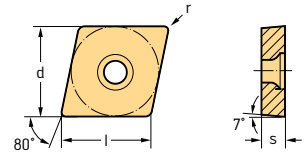

#### Indexable inserts

Designation	l mm	r mm	f mm	a <sub>p</sub> mm	P						M					K			N		S		
					HC						HC					HC			HC		HC		
					WKP01G	WPP10G	WPP20G	WMP20S	WPP30G	WEP01C	WEP10C	WSM01	WSM10S	WMP20S	WSM20S	WSM30S	WKP01G	WKK10S	WKK20S	WN10	WN10	WSM01	WSM10S
CCMT060204-MK4	6.45	0.4	0.08–0.20	0.4–2.0																			
CCMT060208-MK4	6.45	0.8	0.12–0.25	0.5–2.0																			
CCMT09T304-MK4	9.67	0.4	0.08–0.25	0.4–3.0																			
CCMT09T308-MK4	9.67	0.8	0.12–0.32	0.5–3.0																			
CCMT120404-MK4	12.9	0.4	0.12–0.25	0.4–3.5																			
CCMT120408-MK4	12.9	0.8	0.12–0.32	0.5–3.5																			
CCGT060204-MK4	6.45	0.4	0.08–0.20	0.4–2.0																			
CCGT060208-MK4	6.45	0.8	0.12–0.25	0.5–2.0																			
CCGT09T304-MK4	9.67	0.4	0.08–0.25	0.4–3.0																			
CCGT09T308-MK4	9.67	0.8	0.12–0.32	0.5–3.0																			
CCGT120408-MK4	12.9	0.8	0.12–0.32	0.5–3.5																			
CCMT060204-RM4	6.45	0.4	0.12–0.25	0.4–2.5																			
CCMT060208-RM4	6.45	0.8	0.16–0.30	0.6–2.5																			
CCMT09T304-RM4	9.67	0.4	0.12–0.25	0.4–3.0																			
CCMT09T308-RM4	9.67	0.8	0.16–0.35	0.6–4.0																			
CCMT120404-RM4	12.9	0.4	0.12–0.25	0.4–3.0																			
CCMT120408-RM4	12.9	0.8	0.16–0.40	0.6–5.0																			
CCMT120412-RM4	12.9	1.2	0.20–0.50	0.8–5.0																			
CCMT060204-RP4	6.45	0.4	0.12–0.25	0.4–2.5																			
CCMT060208-RP4	6.45	0.8	0.16–0.30	0.6–2.5																			
CCMT09T304-RP4	9.67	0.4	0.12–0.25	0.4–3.0																			
CCMT09T308-RP4	9.67	0.8	0.16–0.35	0.6–4.0																			
CCMT120404-RP4	12.9	0.4	0.12–0.30	0.4–4.0																			
CCMT120408-RP4	12.9	0.8	0.16–0.40	0.6–5.0																			
CCMT120412-RP4	12.9	1.2	0.20–0.50	0.8–5.0																			
CCMT060204-RK4	6.45	0.4	0.12–0.25	0.4–2.5																			
CCMT060208-RK4	6.45	0.8	0.16–0.30	0.6–2.5																			
CCMT09T304-RK4	9.67	0.4	0.12–0.25	0.4–3.0																			
CCMT09T308-RK4	9.67	0.8	0.16–0.35	0.6–4.0																			
CCMT120404-RK4	12.9	0.4	0.12–0.30	0.4–4.0																			
CCMT120408-RK4	12.9	0.8	0.16–0.40	0.6–5.0																			
CCMT120412-RK4	12.9	1.2	0.20–0.50	0.8–5.0																			
CCMW060202-RK6	6.45	0.2	0.08–0.12	0.2–2.5																			
CCMW060204-RK6	6.45	0.4	0.12–0.25	0.4–2.5																			
CCMW060208-RK6	6.45	0.8	0.16–0.30	0.5–2.5																			
CCMW09T304-RK6	9.67	0.4	0.12–0.25	0.4–3.0																			
CCMW09T308-RK6	9.67	0.8	0.16–0.35	0.5–4.0																			
CCMW120408-RK6	12.9	0.8	0.16–0.40	0.6–5.0																			
CCMW120412-RK6	12.9	1.2	0.20–0.50	0.8–5.0																			

See the ISO 1832 designation key for dimensions  
 Ordering example for the grade WPP20G: CCMT060202-FW4 WPP20G

HC = Coated carbide  
 HE = Coated cermet  
 HW = Uncoated carbide



# Turning Insert – Positive rhombic 80°

## CPGT / CPMT / CPMW

### Tiger-tec® Gold

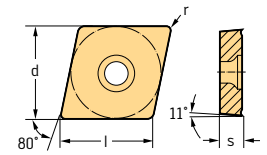

#### Indexable inserts

Designation	l mm	r mm	f mm	a <sub>p</sub> mm	P				M			K		S	
					HC		HE		HC			HC		HC	
					WPP10G	WPP20G	WMP20S	WEP10C	WSM01	WMP20S	WSM20S	WKK20S	WSM01	WSM20S	
CPGT050202M-FP2	5,64	0,17	0,05–0,12	0,2–2,0				☺							
CPGT050204M-FP2	5,64	0,37	0,08–0,20	0,2–2,0				☺							
CPMT050204-FM4	5,64	0,4	0,05–0,16	0,1–1,5			☺			☺	☺				☺
CPMT060204-FM4	6,45	0,4	0,05–0,16	0,1–1,5			☺			☺	☺				☺
CPMT09T304-FM4	9,67	0,4	0,05–0,16	0,1–1,5			☺			☺	☺				☺
CPMT09T308-FM4	9,67	0,8	0,08–0,20	0,1–1,5			☺			☺	☺				☺
CPMT050204-FP4	5,64	0,4	0,05–0,16	0,1–1,5	☺										
CPMT060204-FP4	6,45	0,4	0,05–0,16	0,1–1,5	☺										
CPMT09T304-FP4	9,67	0,4	0,05–0,16	0,1–1,5	☺										
CPMT09T308-FP4	9,67	0,8	0,08–0,20	0,1–1,5	☺										
CPMT04T104-MM4	4,84	0,4	0,06–0,16	0,3–1,5							☺				☺
CPMT060204-MM4	6,45	0,4	0,08–0,20	0,4–2,0							☺				☺
CPMT060208-MM4	6,45	0,8	0,12–0,25	0,5–2,0							☺				☺
CPMT09T304-MM4	9,67	0,4	0,08–0,25	0,4–3,0							☺				☺
CPMT09T308-MM4	9,67	0,8	0,12–0,32	0,5–3,0							☺				☺
CPGT050204-MM4	5,64	0,4	0,08–0,20	0,4–1,5							☺				☺
CPGT060201-MM4	6,45	0,1	0,04–0,12	0,1–2,0							☺				☺
CPGT060202-MM4	6,45	0,2	0,06–0,16	0,2–2,0							☺				☺
CPGT060204-MM4	6,45	0,4	0,08–0,20	0,4–2,0							☺				☺
CPGT060208-MM4	6,45	0,8	0,12–0,25	0,5–2,0							☺				☺
CPGT09T301-MM4	9,67	0,1	0,06–0,20	0,1–3,0							☺				☺
CPGT09T304-MM4	9,67	0,4	0,08–0,25	0,4–3,0							☺				☺
CPGT09T308-MM4	9,67	0,8	0,12–0,32	0,5–3,0							☺				☺
CPMT04T104-MP4	4,84	0,4	0,06–0,16	0,3–1,5							☺				☺
CPMT060204-MP4	6,45	0,4	0,08–0,20	0,4–2,0							☺				☺
CPMT060208-MP4	6,45	0,8	0,12–0,25	0,5–2,0							☺				☺
CPMT09T304-MP4	9,67	0,4	0,08–0,25	0,4–3,0							☺				☺
CPMT09T308-MP4	9,67	0,8	0,12–0,32	0,5–3,0							☺				☺
CPGT050204-MP4	5,64	0,4	0,08–0,20	0,4–1,5							☺				☺
CPGT060204-MP4	6,45	0,4	0,08–0,20	0,4–2,0							☺				☺
CPGT09T304-MP4	9,67	0,4	0,08–0,25	0,4–3,0							☺				☺
CPGT09T308-MP4	9,67	0,8	0,12–0,32	0,5–3,0							☺				☺
CPMT060208-MK4	6,45	0,8	0,12–0,25	0,5–2,0											☺
CPMT09T308-MK4	9,67	0,8	0,12–0,32	0,5–3,0											☺
CPGT050204-MK4	5,64	0,4	0,08–0,20	0,4–1,5											☺
CPGT060204-MK4	6,45	0,4	0,08–0,20	0,4–2,0											☺
CPGT060208-MK4	6,45	0,8	0,12–0,25	0,5–2,0											☺
CPGT09T308-MK4	9,67	0,8	0,12–0,32	0,5–3,0											☺
CPMW050204-RK6	5,64	0,4	0,12–0,25	0,4–2,5											☺
CPMW060204-RK6	6,45	0,4	0,12–0,25	0,4–2,5											☺
CPMW09T304-RK6	9,67	0,4	0,12–0,25	0,4–3,0											☺
CPMW09T308-RK6	9,67	0,8	0,16–0,35	0,5–4,0											☺

See the ISO 1832 designation key for dimensions  
 Ordering example for the grade WEP10C: CPGT050202M-FP2 WEP10C

HC = Coated carbide  
 HE = Coated cermet

#### WALTER SELECT

Optimum indexable insert for → Good = ☺ → Average = ☹ → Poor = ☹☹ machining conditions

☺ ☹ ☹☹ / \* = New addition to the product range





# Turning Insert – Positive rhombic 55°

## DCMT / DCGT / DCMW

### Tiger-tec® Gold

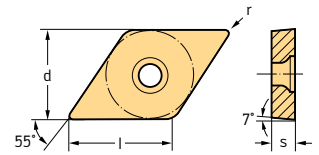

#### Indexable inserts

Designation	l mm	r mm	f mm	a <sub>p</sub> mm	P						M					K			N		S				
					HC						HE		HC					HC			HW		HC		
					WKP01G	WPP10G	WPP20G	WMP20S	WPP30G	WEP01C	WEP10C	WSM01	WSM10S	WMP20S	WSM20S	WSM30S	WKP01G	WKK10S	WKK20S	WN10	WN10	WSM01	WSM10S	WSM20S	WSM30S
DCMT070202-FM4	7.75	0.2	0.04-0.12	0.1-1.0									☉	☉	☉	☉					☉	☉	☉	☉	
DCMT070204-FM4	7.75	0.4	0.05-0.16	0.1-1.5				☉					☉	☉	☉	☉					☉	☉	☉	☉	
DCMT070208-FM4	7.75	0.8	0.08-0.20	0.1-1.5				☉					☉	☉	☉	☉					☉	☉	☉	☉	
DCMT11T302-FM4	11.63	0.2	0.04-0.12	0.1-1.0									☉	☉	☉	☉					☉	☉	☉	☉	
DCMT11T304-FM4	11.63	0.4	0.05-0.16	0.1-1.5				☉					☉	☉	☉	☉					☉	☉	☉	☉	
DCMT11T308-FM4	11.63	0.8	0.08-0.20	0.1-1.5				☉					☉	☉	☉	☉					☉	☉	☉	☉	
DCMT070202-FP4	7.75	0.2	0.04-0.12	0.1-1.0	☉	☉	☉										☉								
DCMT070204-FP4	7.75	0.4	0.05-0.16	0.1-1.5	☉	☉	☉										☉								
DCMT070208-FP4	7.75	0.8	0.08-0.20	0.1-1.5			☉	☉																	
DCMT11T302-FP4	11.63	0.2	0.04-0.12	0.1-1.0	☉	☉	☉										☉								
DCMT11T304-FP4	11.63	0.4	0.05-0.16	0.1-1.5	☉	☉	☉										☉								
DCMT11T308-FP4	11.63	0.8	0.08-0.20	0.1-1.5	☉	☉	☉										☉								
DCMT070204-FM6	7.75	0.4	0.08-0.25	0.3-1.6																			☉	☉	
DCMT11T304-FM6	11.63	0.4	0.08-0.25	0.3-2.0																			☉	☉	
DCMT11T308-FM6	11.63	0.8	0.12-0.32	0.6-2.0																			☉	☉	
DCMT070204-FP6	7.75	0.4	0.06-0.18	0.3-2.0		☉	☉																		
DCMT11T304-FP6	11.63	0.4	0.08-0.20	0.3-2.0		☉	☉																		
DCMT11T308-FP6	11.63	0.8	0.10-0.25	0.5-2.0		☉	☉																		
DCMT070204-FK6	7.75	0.4	0.06-0.18	0.3-2.0													☉	☉							
DCMT11T304-FK6	11.63	0.4	0.08-0.20	0.3-2.0													☉	☉							
DCMT11T308-FK6	11.63	0.8	0.10-0.25	0.5-2.0													☉	☉							
DCMT11T304-MW4	11.63	0.4	0.12-0.40	0.5-4.0		☉	☉										☉	☉					☉	☉	
DCMT11T308-MW4	11.63	0.8	0.15-0.50	0.5-4.0		☉	☉										☉	☉					☉	☉	
<b>Wiper</b>																									
DCGT070201-MN2	7.75	0.1	0.02-0.06	0.5-1.5																		☉	☉		
DCGT070202-MN2	7.75	0.2	0.05-0.12	0.5-2.0																		☉	☉		
DCGT070204-MN2	7.75	0.4	0.08-0.25	0.6-2.5																		☉	☉		
DCGT11T301-MN2	11.63	0.1	0.02-0.06	0.5-1.5																		☉	☉		
DCGT11T302-MN2	11.63	0.2	0.05-0.12	0.5-2.0																		☉	☉		
DCGT11T304-MN2	11.63	0.4	0.08-0.25	0.6-3.0																		☉	☉		
DCGT11T308-MN2	11.63	0.8	0.10-0.30	0.8-3.5																		☉	☉		
DCMT070204-MM4	7.75	0.4	0.08-0.20	0.4-2.0				☉					☉	☉	☉	☉						☉	☉		
DCMT070208-MM4	7.75	0.8	0.12-0.25	0.5-2.0				☉					☉	☉	☉	☉						☉	☉		
DCMT11T302-MM4	11.63	0.2	0.04-0.12	0.2-2.0									☉	☉	☉	☉						☉	☉		
DCMT11T304-MM4	11.63	0.4	0.08-0.25	0.4-3.0				☉					☉	☉	☉	☉						☉	☉		
DCMT11T308-MM4	11.63	0.8	0.12-0.32	0.5-3.0				☉					☉	☉	☉	☉						☉	☉		
DCMT11T312-MM4	11.63	1.2	0.15-0.35	0.5-3.0									☉	☉	☉	☉						☉	☉		
DCGT070204-MM4	7.75	0.4	0.08-0.20	0.4-2.0									☉		☉							☉	☉		
DCGT11T302-MM4	11.63	0.2	0.04-0.12	0.2-2.0									☉		☉							☉	☉		
DCGT11T304-MM4	11.63	0.4	0.08-0.25	0.4-3.0									☉		☉							☉	☉		
DCGT11T308-MM4	11.63	0.8	0.12-0.32	0.5-3.0									☉		☉							☉	☉		

See the ISO 1832 designation key for dimensions  
 Ordering example for the grade WPP20G: DCMT070202-FW4 WPP20G

HC = Coated carbide  
 HE = Coated cermet  
 HW = Uncoated carbide

# Turning Insert – Positive rhombic 55°

## DCMT / DCGT / DCMW

### Tiger-tec® Gold

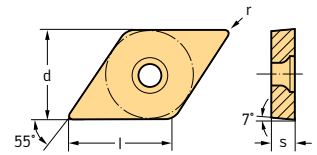

#### Indexable inserts

Designation	l mm	r mm	f mm	a <sub>p</sub> mm	P						M					K			N		S		
					HC						HC					HC			HC		HC		
					WKP01G	WPP10G	WPP20G	WMP20S	WPP30G	WEP01C	WEP10C	WSM01	WSM10S	WMP20S	WSM20S	WSM30S	WKP01G	WKK10S	WKK20S	WN10	WN10	WSM01	WSM10S
DCMT070204-MP4	7.75	0.4	0.08–0.20	0.4–2.0	☺	☺																	
DCMT070208-MP4	7.75	0.8	0.12–0.25	0.5–2.0	☺	☺																	
DCMT11T304-MP4	11.63	0.4	0.08–0.25	0.4–3.0	☺	☺			☹														
DCMT11T308-MP4	11.63	0.8	0.12–0.32	0.5–3.0	☺	☺			☹														
DCMT11T312-MP4	11.63	1.2	0.15–0.35	0.5–3.0	☺	☺																	
DCGT070204-MP4	7.75	0.4	0.08–0.20	0.4–2.0			☺																
DCGT11T304-MP4	11.63	0.4	0.08–0.25	0.4–3.0			☺																
DCGT11T308-MP4	11.63	0.8	0.12–0.32	0.5–3.0			☺																
DCMT11T304-MP6	11.63	0.4	0.10–0.25	0.4–3.5			☺																
DCMT11T308-MP6	11.63	0.8	0.15–0.32	0.6–3.5			☺																
DCMT150404-MP6	15.5	0.4	0.10–0.25	0.4–4.0			☺																
DCMT150408-MP6	15.5	0.8	0.12–0.36	0.6–4.0			☺																
DCMT070204-MK4	7.75	0.4	0.08–0.20	0.4–2.0																			
DCMT070208-MK4	7.75	0.8	0.12–0.25	0.5–2.0																			
DCMT11T304-MK4	11.63	0.4	0.08–0.25	0.4–3.0																			
DCMT11T308-MK4	11.63	0.8	0.12–0.32	0.5–3.0																			
DCMT11T312-MK4	11.63	1.2	0.15–0.35	0.5–3.0																			
DCMT070204-RM4	7.75	0.4	0.12–0.20	0.4–2.0																			
DCMT070208-RM4	7.75	0.8	0.16–0.30	0.6–2.0																			
DCMT11T304-RM4	11.63	0.4	0.12–0.25	0.4–3.0																			
DCMT11T308-RM4	11.63	0.8	0.16–0.35	0.6–4.0																			
DCMT11T312-RM4	11.63	1.2	0.20–0.40	0.8–4.0																			
DCMT070204-RP4	7.75	0.4	0.12–0.20	0.4–2.0																			
DCMT070208-RP4	7.75	0.8	0.16–0.30	0.6–2.0																			
DCMT11T304-RP4	11.63	0.4	0.12–0.25	0.4–3.0																			
DCMT11T308-RP4	11.63	0.8	0.16–0.35	0.6–4.0																			
DCMT11T312-RP4	11.63	1.2	0.20–0.40	0.8–4.0																			
DCMT070204-RK4	7.75	0.4	0.12–0.20	0.4–2.0																			
DCMT11T304-RK4	11.63	0.4	0.12–0.25	0.4–3.0																			
DCMT11T308-RK4	11.63	0.8	0.16–0.35	0.6–4.0																			
DCMT11T312-RK4	11.63	1.2	0.20–0.40	0.8–4.0																			
DCMW11T304-RK6	11.63	0.4	0.12–0.25	0.4–3.0																			
DCMW11T308-RK6	11.63	0.8	0.16–0.35	0.5–4.0																			

See the ISO 1832 designation key for dimensions  
 Ordering example for the grade WPP20G: DCMT070202-FW4 WPP20G

HC = Coated carbide  
 HE = Coated cermet  
 HW = Uncoated carbide

## Turning Insert – Positive rhombic 55° DPMT / DPGT / DPMW Tiger-tec® Gold

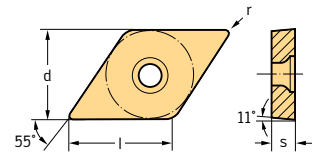

### Indexable inserts

Designation	l mm	r mm	f mm	a <sub>p</sub> mm	P		M		K		S	
					HC	WPP10G WPP20G WMP20S	HC	WSM01 WMP20S WSM20S	HC	WKK20S WSM01	HC	WSM01 WSM20S
DPMT070204-FM4	7.75	0.4	0.05–0.16	0.1–1.5								
DPMT11T304-FM4	11.63	0.4	0.05–0.16	0.1–1.5								
DPMT11T308-FM4	11.63	0.8	0.08–0.20	0.1–1.5								
DPMT070204-FP4	7.75	0.4	0.05–0.16	0.1–1.5								
DPMT11T304-FP4	11.63	0.4	0.05–0.16	0.1–1.5								
DPMT11T308-FP4	11.63	0.8	0.08–0.20	0.1–1.5								
DPMT070204-MM4	7.75	0.4	0.08–0.20	0.4–2.0								
DPMT11T304-MM4	11.63	0.4	0.08–0.25	0.4–3.0								
DPGT11T304-MM4	11.63	0.4	0.08–0.25	0.4–3.0								
DPGT11T308-MM4	11.63	0.8	0.12–0.32	0.5–3.0								
DPMT070204-MP4	7.75	0.4	0.08–0.20	0.4–2.0								
DPMT11T304-MP4	11.63	0.4	0.08–0.25	0.4–3.0								
DPMT11T308-MP4	11.63	0.8	0.12–0.32	0.5–3.0								
DPGT11T304-MP4	11.63	0.4	0.08–0.25	0.4–3.0								
DPMW11T308-RK6	11.63	0.8	0.16–0.35	0.5–4.0								

See the ISO 1832 designation key for dimensions  
Ordering example for the grade WMP20S: DPMT070204-FM4 WMP20S

HC = Coated carbide

## Turning Insert – Positive round RCGT / RCMT / RCMX Tiger-tec® Gold

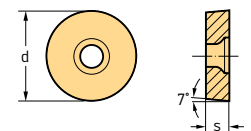

### Indexable inserts

Designation	d mm	f mm	a <sub>p</sub> mm	P		M		K		N		S	
				HC	WPP10G WPP20G WMP20S WPP30G	HC	WSM10S WMP20S WSM20S WSM30S	HC	WKK10S WKK20S	HC	WN10 WN10	HC	WSM10S WSM20S WSM30S
RCGT0602M0-MN2	6	0.10–0.55	0.6–2.5										
RCGT0803M0-MN2	8	0.12–0.60	0.7–3.0										
RCGT10T3M0-MN2	10	0.15–0.70	0.8–4.0										
RCGT120400-MN2	12.7	0.18–0.80	1.0–5.0										
RCGT1204M0-MN2	12	0.18–0.80	1.0–5.0										

See the ISO 1832 designation key for dimensions  
Ordering example for the grade WN10: RCGT0602M0-MN2 WN10

HC = Coated carbide  
HW = Uncoated carbide

### WALTER SELECT

Optimum indexable insert for → Good = ☺ → Average = ☹ → Poor = ☹ machining conditions

☺ ☹ ☹ / ★ = New addition to the product range

ISO indexable inserts – Positive basic shape

## Turning Insert – Positive round

### RCGT / RCMT / RCMX

### Tiger-tec® Gold

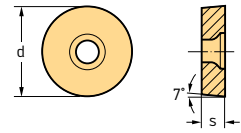

#### Indexable inserts

Designation	d mm	f mm	a <sub>p</sub> mm	P			M				K		N		S		
				HC			HC				HC	HC	HW	HC			
				WPP10G	WPP20G	WMP20S	WPP30G	WSM10S	WMP20S	WSM20S	WSM30S	WKK10S	WKK20S	WN10	WN10	WSM10S	WSM20S
RCMT0602M0-FM4	6	0,07–0,30	0,6–2,5					☺	☺					☺	☺	☺	
RCMT0803M0-FM4	8	0,08–0,30	0,8–3,0					☺	☺	☺				☺	☺	☺	
RCMT10T3M0-FM4	10	0,10–0,35	1,0–4,0					☺	☺	☺				☺	☺	☺	
RCMT1204M0-FM4	12	0,12–0,40	1,2–5,0					☺	☺	☺				☺	☺	☺	
RCMT0602M0-FP4	6	0,07–0,30	0,6–2,5	☺	☺												
RCMT0803M0-FP4	8	0,08–0,30	0,8–3,0	☺	☺												
RCMT10T3M0-FP4	10	0,10–0,35	1,0–4,0	☺	☺												
RCMT1204M0-FP4	12	0,12–0,40	1,2–5,0	☺	☺												
RCMT0602M0-RM4	6	0,08–0,50	0,6–2,5						☺	☺					☺	☺	
RCMT060300-RM4	6,35	0,08–0,5	0,6–2,5						☺	☺					☺	☺	
RCMT0803M0-RM4	8	0,10–0,60	0,8–3,0			☺		☺	☺	☺					☺	☺	
RCMT09T300-RM4	9,525	0,1–0,6	0,8–3			☺		☺	☺	☺					☺	☺	
RCMT10T3M0-RM4	10	0,12–0,80	1,0–4,0			☺		☺	☺	☺					☺	☺	
RCMT120400-RM4	12,7	0,12–1	1,2–5			☺		☺	☺	☺					☺	☺	
RCMT1204M0-RM4	12	0,12–1,00	1,2–5,0			☺		☺	☺	☺					☺	☺	
RCMT1606M0-RM4	16	0,15–1,20	1,6–7,0			☺		☺	☺	☺					☺	☺	
RCMT0602M0-RP4	6	0,08–0,50	0,6–2,5		☺		☺										
RCMT060300-RP4	6,35	0,08–0,50	0,6–2,5		☺		☺										
RCMT0803M0-RP4	8	0,10–0,60	0,8–3,0		☺	☺	☺										
RCMT09T300-RP4	9,525	0,10–0,60	0,8–3,0		☺	☺	☺										
RCMT10T3M0-RP4	10	0,12–0,80	1,0–4,0		☺	☺	☺										
RCMT120400-RP4	12,7	0,12–1,00	1,2–5,0		☺	☺	☺										
RCMT1204M0-RP4	12	0,12–1,00	1,2–5,0		☺	☺	☺										
RCMT1605M0-RP4	16	0,15–1,20	1,6–7,0		☺	☺	☺										
RCMT1606M0-RP4	16	0,15–1,20	1,6–7,0		☺	☺	☺										
RCMT0602M0-RK4	6	0,08–0,50	0,6–2,5								☺						
RCMT0803M0-RK4	8	0,10–0,60	0,8–3,0								☺						
RCMT10T3M0-RK4	10	0,12–0,80	1,0–4,0								☺						
RCMT1204M0-RK4	12	0,12–1,00	1,2–5,0								☺						
RCMT1605M0-RK4	16	0,15–1,20	1,6–7,0								☺						
RCMT1606M0-RK4	16	0,15–1,20	1,6–7,0								☺						
RCMT10T3M0-HU6	10	0,12–0,80	1,0–4,0	☺	☺		☺										
RCMT1204M0-HU6	12	0,12–1,20	1,2–5,0	☺	☺		☺										
RCMT1606M0-HU6	16	0,15–1,20	1,6–7,0	☺	☺		☺										
RCMX2006M0-HU6	20	0,25–1,40	2,0–9,0	☺	☺		☺										
RCMX2507M0-HU6	25	0,30–1,60	2,5–11,0	☺	☺		☺										
RCMX3209M0-HU6	32	0,30–1,70	3,2–15,0	☺	☺		☺										

See the ISO 1832 designation key for dimensions  
Ordering example for the grade WN10: RCGT0602M0-MN2 WN10

HC = Coated carbide  
HW = Uncoated carbide





# Turning Insert – Positive square

## SCGT / SCMT / SCMW

### Tiger-tec® Gold

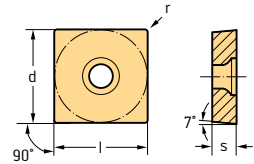

#### Indexable inserts

Designation	l mm	r mm	f mm	ap mm	P					M				K			N		S		
					HC					HC				HC			HC		HC		
					WKP01G	WPP10G	WPP20G	WMP20S	WPP30G	WEP10C	WSM01	WSM10S	WMP20S	WSM20S	WSM30S	WKP01G	WKK10S	WKK20S	WN10	WN10	WSM01
SCGT09T304-MP4	9,53	0,4	0,08–0,25	0,4–3,0			☺														
SCGT09T308-MP4	9,53	0,8	0,12–0,32	0,5–3,0			☺														
SCGT120408-MP4	12,7	0,8	0,12–0,32	0,5–3,5			☺														
SCMT09T304-MK4	9,53	0,4	0,08–0,25	0,4–3,0									☺	☺							
SCMT09T308-MK4	9,53	0,8	0,12–0,32	0,5–3,0									☺	☺							
SCMT120408-MK4	12,7	0,8	0,12–0,32	0,5–3,5									☺	☺							
SCGT09T308-MK4	9,53	0,8	0,12–0,32	0,5–3,0										☺							
SCMT09T304-RM4	9,53	0,4	0,12–0,25	0,4–3,0																☺	☺
SCMT09T308-RM4	9,53	0,8	0,16–0,35	0,6–4,0				☺												☺	☺
SCMT120404-RM4	12,7	0,4	0,12–0,25	0,4–3,0				☺												☺	☺
SCMT120408-RM4	12,7	0,8	0,16–0,40	0,6–5,0				☺												☺	☺
SCMT120412-RM4	12,7	1,2	0,20–0,50	0,8–5,0				☺												☺	☺
SCMT09T304-RP4	9,53	0,4	0,12–0,25	0,4–3,0		☺	☺														
SCMT09T308-RP4	9,53	0,8	0,16–0,35	0,6–4,0		☺	☺														
SCMT09T312-RP4	9,53	1,2	0,20–0,45	0,8–5,0		☺	☺														
SCMT120404-RP4	12,7	0,4	0,12–0,25	0,4–3,0		☺	☺														
SCMT120408-RP4	12,7	0,8	0,16–0,40	0,6–5,0		☺	☺														
SCMT120412-RP4	12,7	1,2	0,20–0,50	0,8–5,0		☺	☺														
SCMT09T304-RK4	9,53	0,4	0,12–0,25	0,4–3,0									☺	☺							
SCMT09T308-RK4	9,53	0,8	0,16–0,35	0,6–4,0									☺	☺							
SCMT120404-RK4	12,7	0,4	0,12–0,25	0,4–3,0									☺	☺							
SCMT120408-RK4	12,7	0,8	0,16–0,40	0,6–5,0									☺	☺							
SCMT120412-RK4	12,7	1,2	0,20–0,50	0,8–5,0									☺	☺							
SCMW09T304-RK6	9,53	0,4	0,12–0,25	0,4–3,0									☺	☺							
SCMW09T308-RK6	9,53	0,8	0,16–0,35	0,6–4,0									☺	☺							
SCMW120404-RK6	12,7	0,4	0,12–0,25	0,4–4,0									☺	☺							
SCMW120408-RK6	12,7	0,8	0,16–0,40	0,6–5,0									☺	☺							
SCMW120412-RK6	12,7	1,2	0,20–0,50	0,8–5,0									☺	☺							

See the ISO 1832 designation key for dimensions  
 Ordering example for the grade WSM20S: SCGT09T304-FM2 WSM20S

HC = Coated carbide  
 HE = Coated cermet  
 HW = Uncoated carbide







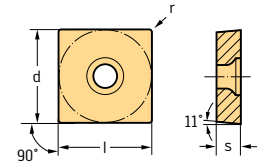

# Turning Insert – Positive square

## SPMT / SPGT / SPMW

### Tiger-tec® Gold



#### Indexable inserts

Designation	l mm	r mm	f mm	a <sub>p</sub> mm	P	M	K	S
					HC	HC	HC	HC
					WPP20G	WSM01 WSM20S	WKK20S	WSM20S
 SPMT09T304-MM4 SPMT09T308-MM4	9,53	0,4	0,08–0,25	0,4–3,0			☺	☺
	9,53	0,8	0,12–0,32	0,5–3,0			☺	☺
 SPGT09T304-MM4 SPGT09T308-MM4	9,53	0,4	0,08–0,25	0,4–3,0			☺	☺
	9,53	0,8	0,12–0,32	0,5–3,0			☺	☺
 SPMT09T304-MP4 SPMT09T308-MP4	9,53	0,4	0,08–0,25	0,4–3,0	☺			
	9,53	0,8	0,12–0,32	0,5–3,0	☺			
 SPMT09T304-MK4 SPMT09T308-MK4	9,53	0,4	0,08–0,25	0,4–3,0				☺
	9,53	0,8	0,12–0,32	0,5–3,0				☺
 SPGT09T304-MK4 SPGT09T308-MK4	9,53	0,4	0,08–0,25	0,4–3,0				☺
	9,53	0,8	0,12–0,32	0,5–3,0				☺
 SPMW09T308-RK6 SPMW120408-RK6	9,53	0,8	0,16–0,35	0,6–4,0		☺		☺
	12,7	0,8	0,16–0,40	0,6–5,0				☺

See the ISO 1832 designation key for dimensions  
 Ordering example for the grade WSM20S: SPMT09T304-MM4 WSM20S

HC = Coated carbide

## Turning Insert – Positive triangular 60°

### TCMT / TCGT / TCMW

### Tiger-tec® Gold

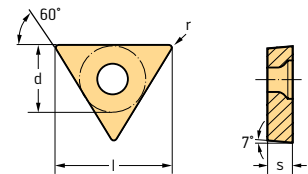

#### Indexable inserts

Designation	l mm	r mm	f mm	a <sub>p</sub> mm	P								M				K			N		S			
					HC				HE				HC				HC			HC HW		HC			
					WKP01G	WPP10G	WPP20G	WMP20S	WPP30G	WEP01C	WEP10C	WSM01	WSM10S	WMP20S	WSM20S	WSM21	WSM30S	WKP01G	WKK10S	WKK20S	WNN10	WN10	WSM01	WSM10S	WSM20S
Wiper	TCMT090202-FW4	9,62	0,2	0,03–0,15	0,1–1,5																				
	TCMT090204-FW4	9,62	0,4	0,05–0,30	0,2–2,0																				
	TCMT110204-FW4	11	0,4	0,07–0,30	0,2–2,5																				
	TCMT110208-FW4	11	0,8	0,12–0,40	0,3–2,5																				
	TCMT16T304-FW4	16,5	0,4	0,07–0,35	0,2–2,5																				
	TCMT16T308-FW4	16,5	0,8	0,12–0,50	0,3–2,5																				
	TCGT06T101-FN2	6,87	0,1	0,02–0,06	0,1–1,5																				
	TCGT06T102-FN2	6,87	0,2	0,05–0,12	0,2–2,0																				
	TCGT06T104-FN2	6,87	0,4	0,08–0,25	0,2–2,5																				
	TCGT090202-FN2	9,62	0,2	0,05–0,12	0,2–2,0																				
	TCGT090204-FN2	9,62	0,4	0,08–0,25	0,2–2,5																				
	TCGT110202-FN2	11	0,2	0,05–0,12	0,2–2,0																				
	TCGT110204-FN2	11	0,4	0,08–0,25	0,2–2,5																				
	TCGT16T304-FN2	16,5	0,4	0,08–0,25	0,2–2,5																				
	TCGT16T308-FN2	16,5	0,8	0,10–0,30	0,3–3,0																				
	TCGT06T101-FM2	6,87	0,1	0,02–0,06	0,1–1,5																				
	TCGT06T102-FM2	6,87	0,2	0,05–0,12	0,2–2,0																				
	TCGT06T104-FM2	6,87	0,4	0,08–0,25	0,2–2,5																				
	TCGT090202-FM2	9,62	0,2	0,05–0,12	0,2–2,0																				
	TCGT090204-FM2	9,62	0,4	0,08–0,25	0,2–2,5																				
	TCGT110201-FM2	11	0,1	0,02–0,06	0,1–1,5																				
	TCGT110202-FM2	11	0,2	0,05–0,12	0,2–2,0																				
	TCGT110204-FM2	11	0,4	0,08–0,25	0,2–2,5																				
	TCGT16T302-FM2	16,5	0,2	0,05–0,12	0,2–2,0																				
	TCGT06T104M-FP2	6,87	0,37	0,08–0,25	0,2–2,0																				
	TCGT090204M-FP2	9,62	0,37	0,08–0,25	0,2–2,5																				
	TCGT110202M-FP2	11	0,17	0,05–0,12	0,2–2,0																				
	TCGT110204M-FP2	11	0,37	0,08–0,25	0,2–2,5																				
	TCGT090204MR-FX4	9,62	0,37	0,05–0,15	0,1–2,0																				
	TCGT110204MR-FX4	11	0,37	0,05–0,15	0,1–2,0																				
	TCGT090204ML-FX4	9,62	0,37	0,05–0,15	0,1–2,0																				
TCGT110204ML-FX4	11	0,37	0,05–0,15	0,1–2,0																					

See the ISO 1832 designation key for dimensions

Ordering example for the grade WPP20G: TCMT090202-FW4 WPP20G

HC = Coated carbide

HE = Coated cermet

HW = Uncoated carbide

# Turning Insert – Positive triangular 60°

## TCMT / TCGT / TCMW

### Tiger-tec® Gold

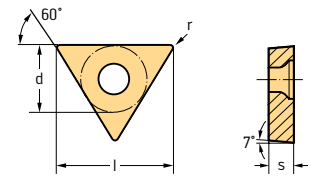

### Indexable inserts

Designation	l mm	r mm	f mm	a <sub>p</sub> mm	P						M					K			N		S					
					HC			HE			HC					HC			HC HW		HC					
					WKP01G	WPP10G	WPP20G	WPP20S	WPP30G	WEP01C	WEP10C	WSM01	WSM10S	WMP20S	WSM20S	WSM21	WSM30S	WKP01G	WKK10S	WKK20S	WN10	WN10	WSM01	WSM10S	WSM20S	WSM21
TCMT06T102-FM4	6.87	0.2	0.02-0.10	0.1-1.0																						
TCMT06T104-FM4	6.87	0.4	0.04-0.17	0.1-1.0																						
TCMT090202-FM4	9.62	0.2	0.04-0.12	0.1-1.0																						
TCMT090204-FM4	9.62	0.4	0.05-0.16	0.1-1.5																						
TCMT090208-FM4	9.62	0.8	0.08-0.20	0.1-1.5																						
TCMT110202-FM4	11	0.2	0.04-0.12	0.1-1.0																						
TCMT110204-FM4	11	0.4	0.05-0.16	0.1-1.5																						
TCMT110208-FM4	11	0.8	0.08-0.20	0.1-1.5																						
TCMT16T302-FM4	16.5	0.2	0.04-0.12	0.1-1.0																						
TCMT16T304-FM4	16.5	0.4	0.05-0.16	0.1-1.5																						
TCMT16T308-FM4	16.5	0.8	0.08-0.20	0.1-1.5																						
TCMT06T102-FP4	6.87	0.2	0.02-0.10	0.1-1.0																						
TCMT06T104-FP4	6.87	0.4	0.04-0.17	0.1-1.0																						
TCMT090202-FP4	9.62	0.2	0.04-0.12	0.1-1.0																						
TCMT090204-FP4	9.62	0.4	0.05-0.16	0.1-1.5																						
TCMT090208-FP4	9.62	0.8	0.08-0.20	0.1-1.5																						
TCMT110202-FP4	11	0.2	0.04-0.12	0.1-1.0																						
TCMT110204-FP4	11	0.4	0.05-0.16	0.1-1.5																						
TCMT110208-FP4	11	0.8	0.08-0.20	0.1-1.5																						
TCMT16T302-FP4	16.5	0.2	0.04-0.12	0.1-1.0																						
TCMT16T304-FP4	16.5	0.4	0.05-0.16	0.1-1.5																						
TCMT16T308-FP4	16.5	0.8	0.08-0.20	0.1-1.5																						
TCMT110204-FM6	11	0.4	0.08-0.25	0.3-1.6																						
TCMT110208-FM6	11	0.8	0.12-0.30	0.5-1.6																						
TCMT16T304-FM6	16.5	0.4	0.08-0.25	0.3-2.0																						
TCMT16T308-FM6	16.5	0.8	0.12-0.32	0.5-2.5																						
TCMT110204-FP6	11	0.4	0.06-0.18	0.3-2.0																						
TCMT110208-FP6	11	0.8	0.10-0.20	0.5-2.0																						
TCMT16T304-FP6	16.5	0.4	0.08-0.20	0.3-2.0																						
TCMT16T308-FP6	16.5	0.8	0.10-0.25	0.5-2.0																						
TCMT110204-FK6	11	0.4	0.06-0.18	0.3-2.0																						
TCMT110208-FK6	11	0.8	0.10-0.20	0.5-2.0																						
TCMT16T304-FK6	16.5	0.4	0.08-0.20	0.3-2.0																						
TCMT16T308-FK6	16.5	0.8	0.10-0.25	0.5-2.0																						
TCMT16T304-MW4	16.5	0.4	0.12-0.40	0.5-4.0																						
TCMT16T308-MW4	16.5	0.8	0.15-0.50	0.5-4.0																						

See the ISO 1832 designation key for dimensions  
 Ordering example for the grade WPP20G: TCMT090202-FW4 WPP20G

HC = Coated carbide  
 HE = Coated cermet  
 HW = Uncoated carbide

# Turning Insert – Positive triangular 60°

## TCMT / TCGT / TCMW

### Tiger-tec® Gold

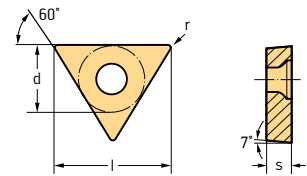

#### Indexable inserts

Designation	l mm	r mm	f mm	ap mm	P						M					K			N		S					
					WKP01G	WPP10G	WPP20G	WMP20S	WPP30G	WEP01C	WEP10C	WSM01	WSM10S	WMP20S	WSM20S	WSM21	WSM30S	WKP01G	WKK10S	WKK20S	WNN10	WN10	WSM01	WSM10S	WSM20S	WSM21
TCMT110201-MN2	11	0.1	0.02–0.06	0.5–1.5																						
TCMT110202-MN2	11	0.2	0.05–0.12	0.6–2.0																						
TCMT110204-MN2	11	0.4	0.08–0.25	0.6–3.0																						
TCMT16T302-MN2	16.5	0.2	0.05–0.12	0.5–2.0																						
TCMT16T304-MN2	16.5	0.4	0.08–0.25	0.6–4.0																						
TCMT16T308-MN2	16.5	0.8	0.10–0.35	0.8–4.0																						
TCMT090204-MM4	9.62	0.4	0.08–0.20	0.4–2.0																						
TCMT090208-MM4	9.62	0.8	0.12–0.25	0.5–2.0																						
TCMT110204-MM4	11	0.4	0.08–0.20	0.4–2.0																						
TCMT110208-MM4	11	0.8	0.12–0.30	0.5–2.0																						
TCMT16T304-MM4	16.5	0.4	0.08–0.25	0.4–3.0																						
TCMT16T308-MM4	16.5	0.8	0.12–0.32	0.5–3.0																						
TCGT090204-MM4	9.62	0.4	0.08–0.20	0.4–2.0																						
TCGT110204-MM4	11	0.4	0.08–0.20	0.4–2.0																						
TCGT110208-MM4	11	0.8	0.12–0.30	0.5–2.0																						
TCGT16T308-MM4	16.5	0.8	0.12–0.32	0.5–3.0																						
TCMT090204-MP4	9.62	0.4	0.08–0.20	0.4–2.0																						
TCMT090208-MP4	9.62	0.8	0.12–0.25	0.5–2.0																						
TCMT110204-MP4	11	0.4	0.08–0.20	0.4–2.0																						
TCMT110208-MP4	11	0.8	0.12–0.30	0.5–2.0																						
TCMT16T304-MP4	16.5	0.4	0.08–0.25	0.4–3.0																						
TCMT16T308-MP4	16.5	0.8	0.12–0.32	0.5–3.0																						
TCMT220408-MP4	22	0.8	0.12–0.32	0.5–3.5																						
TCGT090204-MP4	9.62	0.4	0.08–0.20	0.4–2.0																						
TCGT110204-MP4	11	0.4	0.08–0.20	0.4–2.0																						
TCGT110208-MP4	11	0.8	0.12–0.30	0.5–2.0																						
TCMT110204-MP6	11	0.4	0.10–0.20	0.4–2.5																						
TCMT110304-MP6	11	0.4	0.12–0.25	0.4–3.0																						
TCMT16T304-MP6	16.5	0.4	0.10–0.25	0.4–3.5																						
TCMT16T308-MP6	16.5	0.8	0.15–0.32	0.6–3.5																						
TCMT090204-MK4	9.62	0.4	0.08–0.20	0.4–2.0																						
TCMT090208-MK4	9.62	0.8	0.12–0.25	0.5–2.0																						
TCMT110204-MK4	11	0.4	0.08–0.20	0.4–2.0																						
TCMT110208-MK4	11	0.8	0.12–0.30	0.5–2.0																						
TCMT16T304-MK4	16.5	0.4	0.08–0.25	0.4–3.0																						
TCMT16T308-MK4	16.5	0.8	0.12–0.32	0.5–3.0																						
TCGT110204-MK4	11	0.4	0.08–0.20	0.4–2.0																						
TCGT16T308-MK4	16.5	0.8	0.12–0.32	0.5–3.0																						

See the ISO 1832 designation key for dimensions  
 Ordering example for the grade WPP20G: TCMT090202-FW4 WPP20G

HC = Coated carbide  
 HE = Coated cermet  
 HW = Uncoated carbide

# Turning Insert – Positive triangular 60°

## TCMT / TCGT / TCMW

### Tiger-tec® Gold

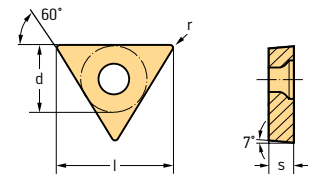

#### Indexable inserts

Designation	l mm	r mm	f mm	a <sub>p</sub> mm	P				M				K			N		S							
					HC				HE				HC				HC			HW		HC			
					WKP01G	WPP10G	WPP20G	WMP20S	WPP30G	WEP01C	WEP10C	WSM01	WSM10S	WMP20S	WSM20S	WSM21	WSM30S	WKP01G	WKK10S	WKK20S	WNN10	WN10	WSM01	WSM10S	WSM20S
	TCMT090204-RM4	9,62	0,4	0,12–0,25	0,4–3,0																				
	TCMT090208-RM4	9,62	0,8	0,16–0,30	0,6–3,0																				
	TCMT110204-RM4	11	0,4	0,12–0,25	0,4–3,0																				
	TCMT110208-RM4	11	0,8	0,16–0,30	0,6–3,0																				
	TCMT16T304-RM4	16,5	0,4	0,12–0,25	0,4–3,0																				
	TCMT16T308-RM4	16,5	0,8	0,16–0,35	0,6–4,0																				
	TCMT16T312-RM4	16,5	1,2	0,20–0,40	0,8–4,0																				
	TCMT090204-RP4	9,62	0,4	0,12–0,25	0,4–3,0																				
	TCMT090208-RP4	9,62	0,8	0,16–0,30	0,6–3,0																				
	TCMT110204-RP4	11	0,4	0,12–0,25	0,4–3,0																				
	TCMT110208-RP4	11	0,8	0,16–0,30	0,6–3,0																				
	TCMT16T304-RP4	16,5	0,4	0,12–0,25	0,4–3,0																				
	TCMT16T308-RP4	16,5	0,8	0,16–0,35	0,6–4,0																				
	TCMT16T312-RP4	16,5	1,2	0,20–0,40	0,8–4,0																				
	TCMT090204-RK4	9,62	0,4	0,12–0,25	0,4–3,0																				
	TCMT090208-RK4	9,62	0,8	0,16–0,30	0,6–3,0																				
	TCMT110204-RK4	11	0,4	0,12–0,25	0,4–3,0																				
	TCMT110208-RK4	11	0,8	0,16–0,30	0,6–3,0																				
	TCMT16T304-RK4	16,5	0,4	0,12–0,25	0,4–3,0																				
	TCMT16T308-RK4	16,5	0,8	0,16–0,35	0,6–4,0																				
	TCMT16T312-RK4	16,5	1,2	0,20–0,40	0,8–4,0																				
	TCMW110204-RK6	11	0,4	0,12–0,25	0,4–3,0																				
	TCMW110208-RK6	11	0,8	0,16–0,30	0,6–3,0																				
	TCMW16T304-RK6	16,5	0,4	0,12–0,25	0,4–3,0																				
	TCMW16T308-RK6	16,5	0,8	0,16–0,35	0,6–4,0																				

See the ISO 1832 designation key for dimensions  
 Ordering example for the grade WPP20G: TCMT090202-FW4 WPP20G

HC = Coated carbide  
 HE = Coated cermet  
 HW = Uncoated carbide

## Turning Insert – Positive triangular 60°

### TPMT / TPGT / TPMW / TPMR / TPGN

### Tiger-tec® Gold

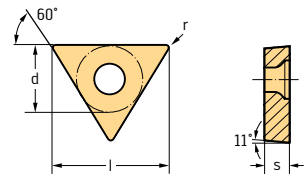

#### Indexable inserts

Designation	l mm	r mm	f mm	a <sub>p</sub> mm	P		M		K		S	
					HC		HC		HC		HC	
					WPP10G	WPP20G	WMP20S	WSM01	WMP20S	WSM20S	WKK20S	WSM01
TPMT110204-FM4	11	0,4	0,05–0,16	0,1–1,5			☞					☞
	TPMT16T304-FM4	16,5	0,4	0,05–0,16	0,1–1,5			☞				☞
TPMT110204-FP4	11	0,4	0,05–0,16	0,1–1,5	☞							
	TPMT16T304-FP4	16,5	0,4	0,05–0,16	0,1–1,5	☞						
TPMT090204-MM4	9,62	0,4	0,08–0,20	0,4–2,0								☞
	TPMT110204-MM4	11	0,4	0,08–0,20	0,4–2,0							☞
	TPMT16T304-MM4	16,5	0,4	0,08–0,25	0,4–3,0							☞
	TPMT16T308-MM4	16,5	0,8	0,12–0,32	0,5–3,0							☞
TPGT090204-MM4	9,62	0,4	0,08–0,20	0,4–2,0				☞				☞
	TPGT110204-MM4	11	0,4	0,08–0,20	0,4–2,0			☞				☞
	TPGT110208-MM4	11	0,8	0,12–0,30	0,5–2,0							☞
	TPGT16T304-MM4	16,5	0,4	0,08–0,25	0,4–3,0			☞				☞
TPGT16T308-MM4	16,5	0,8	0,12–0,32	0,5–3,0			☞				☞	
TPMT090204-MP4	9,62	0,4	0,08–0,20	0,4–2,0								
	TPMT110204-MP4	11	0,4	0,08–0,20	0,4–2,0							
	TPMT110208-MP4	11	0,8	0,12–0,30	0,5–2,0							
	TPMT16T304-MP4	16,5	0,4	0,08–0,25	0,4–3,0							
	TPMT16T308-MP4	16,5	0,8	0,12–0,32	0,5–3,0							
TPGT090204-MP4	9,62	0,4	0,08–0,20	0,4–2,0								
	TPGT110204-MP4	11	0,4	0,08–0,20	0,4–2,0							
	TPGT16T304-MP4	16,5	0,4	0,08–0,25	0,4–3,0							
	TPGT16T308-MP4	16,5	0,8	0,12–0,32	0,5–3,0							
TPMT090204-MK4	9,62	0,4	0,08–0,20	0,4–2,0								
	TPMT090208-MK4	9,62	0,8	0,12–0,20	0,5–2,0							
	TPMT110204-MK4	11	0,4	0,08–0,20	0,4–2,0							
	TPMT16T304-MK4	16,5	0,4	0,08–0,25	0,4–3,0							
	TPMT16T308-MK4	16,5	0,8	0,12–0,32	0,5–3,0							
TPGT090204-MK4	9,62	0,4	0,08–0,20	0,4–2,0								
	TPGT110208-MK4	11	0,8	0,12–0,30	0,5–2,0							
TPMW110204-RK6	11	0,4	0,12–0,25	0,4–2,5								
	TPMW16T304-RK6	16,5	0,4	0,12–0,25	0,4–3,0							
	TPMW16T308-RK6	16,5	0,8	0,16–0,35	0,6–4,0							
TPMR110304	11	0,4	0,12–0,25	0,4–3,0								
	TPMR110308	11	0,8	0,12–0,25	0,4–3,0							
	TPMR160304	16,5	0,4	0,12–0,25	0,4–3,0							
	TPMR160308	16,5	0,8	0,16–0,30	0,6–4,0							
TPGN110308	11	0,8	0,12–0,20	0,8–2,0								
	TPGN160304	16,5	0,4	0,10–0,25	0,4–3,0							
	TPGN160308	16,5	0,8	0,12–0,30	0,8–3,0							

See the ISO 1832 designation key for dimensions

HC = Coated carbide

Ordering example for the grade WMP20S: TPMT110204-FM4 WMP20S

# Turning Insert – Positive rhombic 35°

## VBGT / VCGT / VCMT / VBMT / VCMW

### Tiger-tec® Gold

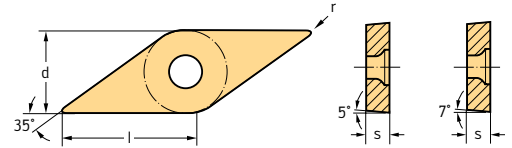

#### Indexable inserts

Designation	l mm	r mm	f mm	a <sub>p</sub> mm	P							M				K			N		S						
					HC							HE				HC				HC			HW		HC		
					WKP01G	WPP10G	WPP20G	WMP20S	WPP30G	WEP01C	WEP10C	WSM01	WSM10S	WMP20S	WSM20S	WSM30S	WKP01G	WKK10S	WKK20S	WNN10	WNI10	WSM01	WSM10S	WSM20S	WSM30S		
VBGT110302-FL2	11.07	0.2	0.04–0.10	0.1–1.0		☉												☉									
VBGT110304-FL2	11.07	0.4	0.06–0.15	0.2–1.5		☉												☉									
VCGT110301-FN2	11.07	0.1	0.02–0.06	0.1–1.5														☉									
VCGT110302-FN2	11.07	0.2	0.05–0.12	0.2–2.0														☉	☉								
VCGT110304-FN2	11.07	0.4	0.08–0.25	0.2–2.5														☉	☉								
VCGT160402-FN2	16.61	0.2	0.05–0.12	0.2–2.0														☉	☉								
VCGT160404-FN2	16.61	0.4	0.08–0.25	0.2–2.5														☉	☉								
VCGT160408-FN2	16.61	0.8	0.10–0.30	0.3–3.0														☉	☉								
VCGT110301-FM2	11.07	0.1	0.02–0.06	0.1–1.5																		☉					
VCGT110302-FM2	11.07	0.2	0.05–0.12	0.2–2.0																		☉					
VCGT110304-FM2	11.07	0.4	0.08–0.25	0.2–2.5																		☉					
VCGT160402-FM2	16.61	0.2	0.05–0.12	0.2–2.0																		☉					
VCGT160404-FM2	16.61	0.4	0.08–0.25	0.2–2.5																		☉					
VCGT160408-FM2	16.61	0.8	0.10–0.30	0.3–3.0																		☉					
VCGT1103005M-FP2	11.07	0.03	0.01–0.04	0.1–1.0																		☉					
VCGT110301M-FP2	11.07	0.07	0.02–0.06	0.1–1.5																		☉					
VCGT110302M-FP2	11.07	0.17	0.05–0.12	0.2–2.0																		☉					
VCGT110304M-FP2	11.07	0.37	0.08–0.25	0.2–2.5																		☉					
VCGT160402M-FP2	16.61	0.17	0.05–0.12	0.2–2.0																		☉					
VCGT160404M-FP2	16.61	0.37	0.08–0.25	0.2–2.5																		☉					
VCGT160408M-FP2	16.61	0.77	0.10–0.30	0.3–3.0																		☉					
VCGT110302MR-FX4	11.07	0.17	0.02–0.10	0.1–1.5																		☉					
VCGT110304MR-FX4	11.07	0.37	0.05–0.15	0.1–2.0																		☉					
VCGT160404MR-FX4	16.61	0.37	0.05–0.15	0.1–2.0																		☉					
VCGT110302ML-FX4	11.07	0.17	0.02–0.10	0.1–1.5																		☉					
VCGT110304ML-FX4	11.07	0.37	0.05–0.15	0.1–2.0																		☉					
VCGT160404ML-FX4	16.61	0.37	0.05–0.15	0.1–2.0																		☉					
VCMT110302-FM4	11.07	0.2	0.04–0.12	0.1–1.0			☉															☉					
VCMT110304-FM4	11.07	0.4	0.05–0.16	0.1–1.5			☉															☉					
VCMT160402-FM4	16.61	0.2	0.04–0.12	0.1–1.0			☉															☉					
VCMT160404-FM4	16.61	0.4	0.05–0.16	0.1–1.5			☉															☉					
VCMT160408-FM4	16.61	0.8	0.08–0.20	0.1–1.5			☉															☉					
VCMT110302-FP4	11.07	0.2	0.04–0.12	0.1–1.0		☉	☉	☉														☉					
VCMT110304-FP4	11.07	0.4	0.05–0.16	0.1–1.5		☉	☉	☉														☉					
VCMT160402-FP4	16.61	0.2	0.04–0.12	0.1–1.0		☉	☉	☉														☉					
VCMT160404-FP4	16.61	0.4	0.05–0.16	0.1–1.5		☉	☉	☉														☉					
VCMT160408-FP4	16.61	0.8	0.08–0.20	0.1–1.5		☉	☉	☉														☉					
VBMT110304-FM6	11.07	0.4	0.08–0.20	0.3–1.6																		☉					
VBMT110308-FM6	11.07	0.8	0.12–0.30	0.5–1.6																		☉					
VBMT160404-FM6	16.61	0.4	0.08–0.20	0.3–2.0																		☉					
VBMT160408-FM6	16.61	0.8	0.12–0.30	0.6–2.5																		☉					
VBMT160412-FM6	16.61	1.2	0.15–0.30	1.0–2.5																		☉					

See the ISO 1832 designation key for dimensions  
 Ordering example for the grade WPP20G: VBGT110302-FL2 WPP20G

HC = Coated carbide  
 HE = Coated cermet  
 HW = Uncoated carbide

#### WALTER SELECT

Optimum indexable insert for → Good = ☉ → Average = ☉ → Poor = ☹ machining conditions

☉ ☉ ☉ / \* = New addition to the product range



# Turning Insert – Positive rhombic 35°

## VBGT / VCGT / VCMT / VBMT / VCMW

### Tiger-tec® Gold

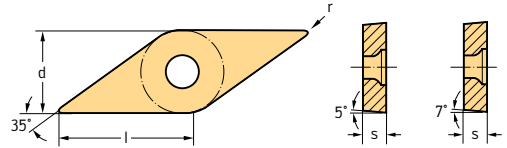

#### Indexable inserts

Designation	l mm	r mm	f mm	ap mm	P				M				K			N		S				
					HC				HC				HC			HC		HC				
					WKP10G	WPP10G	WPP20G	WMP20S	WPP30G	WEP10C	WEP10C	WSM01	WSM10S	WMP20S	WSM20S	WSM30S	WKP10G	WKK10S	WKK20S	WNN10	WNI10	WSM01
VBMT110304-FP6	11.07	0.4	0.06-0.18	0.3-2.0	☺	☺																
VBMT110308-FP6	11.07	0.8	0.10-0.20	0.5-2.0	☺	☺																
VBMT160404-FP6	16.61	0.4	0.08-0.20	0.3-2.0	☺	☺																
VBMT160406-FP6	16.61	0.6	0.10-0.25	0.4-2.0	☺	☺																
VBMT160408-FP6	16.61	0.8	0.10-0.25	0.5-2.0	☺	☺																
VBMT160412-FP6	16.61	1.2	0.12-0.30	0.6-2.0	☺	☺																
VBMT110304-FK6	11.07	0.4	0.06-0.18	0.3-2.0										☺								
VBMT160404-FK6	16.61	0.4	0.08-0.20	0.3-2.0										☺	☺							
VBMT160406-FK6	16.61	0.6	0.10-0.25	0.4-2.0										☺	☺							
VBMT160408-FK6	16.61	0.8	0.10-0.25	0.5-2.0										☺	☺							
VBMT160412-FK6	16.61	1.2	0.12-0.30	0.6-2.0											☺							
VCGT110301-MN2	11.07	0.1	0.02-0.06	0.5-1.5												☺	☺					
VCGT110302-MN2	11.07	0.2	0.05-0.12	0.5-2.0												☺	☺					
VCGT110304-MN2	11.07	0.4	0.08-0.25	0.6-2.5												☺	☺					
VCGT110308-MN2	11.07	0.8	0.10-0.35	0.8-3.0												☺	☺					
VCGT130301-MN2	13.1	0.1	0.02-0.06	0.5-1.5												☺						
VCGT130302-MN2	13.1	0.2	0.05-0.12	0.5-2.0												☺	☺					
VCGT130304-MN2	13.1	0.4	0.08-0.25	0.6-3.0												☺	☺					
VCGT160404-MN2	16.61	0.4	0.08-0.25	0.6-3.5							☺					☺	☺	☺				
VCGT160408-MN2	16.61	0.8	0.10-0.35	0.8-3.5							☺					☺	☺	☺				
VCGT160412-MN2	16.61	1.2	0.10-0.45	1.0-3.5							☺					☺	☺					
VBMT110302-MM4	11.07	0.2	0.05-0.12	0.2-1.5							☺								☺			
VBMT110304-MM4	11.07	0.4	0.08-0.20	0.4-1.5			☺				☺	☺							☺	☺		
VBMT110308-MM4	11.07	0.8	0.12-0.25	0.5-1.5				☺			☺	☺							☺	☺	☺	
VBMT160402-MM4	16.61	0.2	0.05-0.12	0.2-2.0							☺								☺			
VBMT160404-MM4	16.61	0.4	0.08-0.20	0.4-2.0				☺			☺	☺	☺						☺	☺	☺	☺
VBMT160408-MM4	16.61	0.8	0.12-0.30	0.5-2.0				☺			☺	☺	☺						☺	☺	☺	☺
VBMT160412-MM4	16.61	1.2	0.12-0.32	0.5-2.0							☺	☺							☺	☺		☺
VCMT160404-MM4	16.61	0.4	0.08-0.20	0.4-2.0				☺			☺	☺							☺	☺		
VCMT160408-MM4	16.61	0.8	0.12-0.30	0.5-2.0				☺			☺	☺							☺	☺		
VCGT110302-MM4	11.07	0.2	0.05-0.12	0.2-1.5							☺								☺			
VCGT110304-MM4	11.07	0.4	0.08-0.20	0.4-1.5							☺								☺			
VCGT160402-MM4	16.61	0.2	0.05-0.12	0.2-2.0							☺								☺			
VCGT160404-MM4	16.61	0.4	0.08-0.20	0.4-2.0							☺								☺			
VCGT160408-MM4	16.61	0.8	0.12-0.30	0.5-2.0							☺								☺			
VBMT110304-MP4	11.07	0.4	0.08-0.20	0.4-1.5		☺	☺															
VBMT110308-MP4	11.07	0.8	0.12-0.25	0.5-1.5		☺	☺															
VBMT160404-MP4	16.61	0.4	0.08-0.20	0.4-2.0		☺	☺															
VBMT160406-MP4	16.61	0.6	0.12-0.25	0.5-2.0		☺	☺															
VBMT160408-MP4	16.61	0.8	0.12-0.30	0.5-2.0		☺	☺															
VBMT160412-MP4	16.61	1.2	0.12-0.32	0.5-2.0		☺	☺															
VCMT160404-MP4	16.61	0.4	0.08-0.20	0.4-2.0		☺	☺															
VCMT160408-MP4	16.61	0.8	0.12-0.30	0.5-2.0		☺	☺															

See the ISO 1832 designation key for dimensions  
 Ordering example for the grade WPP20G: VBGT110302-FL2 WPP20G

HC = Coated carbide  
 HE = Coated cermet  
 HW = Uncoated carbide

#### WALTER SELECT

Optimum indexable insert for → Good = ☺ → Average = ☹ → Poor = ☹☹ machining conditions

# Turning Insert – Positive rhombic 35°

## VBGT / VCGT / VCMT / VBMT / VCMW

### Tiger-tec® Gold

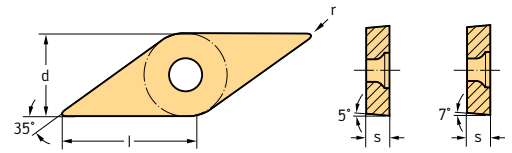

#### Indexable inserts

Designation	l mm	r mm	f mm	a <sub>p</sub> mm	P						M					K			N		S			
					HC			HE			HC					HC			HC HW		HC			
					WKP01G	WPP10G	WPP20G	WMP20S	WPP30G	WEP01C	WEP10C	WSM01	WSM10S	WMP20S	WSM20S	WSM30S	WKP01G	WKK10S	WKK20S	WNN10	WN10	WSM01	WSM10S	WSM20S
VBMT160404-MP6	16.61	0.4	0.10–0.25	0.4–2.5	☺	☺																		
VBMT160408-MP6	16.61	0.8	0.15–0.30	0.6–2.5	☺	☺																		
VBMT160404-MK4	16.61	0.4	0.08–0.20	0.4–2.0											☺	☺								
VBMT160408-MK4	16.61	0.8	0.12–0.30	0.5–2.0											☺	☺								
VBMT160412-MK4	16.61	1.2	0.12–0.32	0.5–2.0												☺								
VCMT110304-RM4	11.07	0.4	0.12–0.20	0.4–2.5				☺			☺	☺	☺								☺	☺	☺	☺
VCMT110308-RM4	11.07	0.8	0.16–0.25	0.6–3.0							☺	☺	☺								☺	☺	☺	☺
VCMT160404-RM4	16.61	0.4	0.12–0.25	0.4–2.5				☺			☺	☺	☺								☺	☺	☺	☺
VCMT160408-RM4	16.61	0.8	0.16–0.30	0.6–3.0				☺			☺	☺	☺								☺	☺	☺	☺
VCMT160412-RM4	16.61	1.2	0.20–0.35	0.8–4.0							☺	☺									☺	☺		☺
VCMT110304-RP4	11.07	0.4	0.12–0.20	0.4–2.5	☺	☺		☺																
VCMT110308-RP4	11.07	0.8	0.16–0.25	0.6–3.0	☺	☺																		
VCMT160404-RP4	16.61	0.4	0.12–0.25	0.4–2.5	☺	☺		☺																
VCMT160406-RP4	16.61	0.6	0.15–0.25	0.6–3.0	☺	☺																		
VCMT160408-RP4	16.61	0.8	0.16–0.30	0.6–3.0	☺	☺		☺																
VCMT160412-RP4	16.61	1.2	0.20–0.35	0.8–3.0	☺	☺		☺																
VCMT110304-RK4	11.07	0.4	0.12–0.20	0.4–2.5												☺								
VCMT110308-RK4	11.07	0.8	0.16–0.25	0.6–3.0											☺	☺								
VCMT160404-RK4	16.61	0.4	0.12–0.25	0.4–2.5											☺	☺								
VCMT160408-RK4	16.61	0.8	0.16–0.30	0.6–3.0											☺	☺								
VCMT160412-RK4	16.61	1.2	0.20–0.35	0.8–3.0											☺	☺								
VCMW160404-RK6	16.61	0.4	0.12–0.25	0.4–2.5											☺	☺								
VCMW160408-RK6	16.61	0.8	0.16–0.30	0.6–3.0											☺	☺								
VCMW160412-RK6	16.61	1.2	0.20–0.35	0.8–3.0											☺									

See the ISO 1832 designation key for dimensions  
 Ordering example for the grade WPP20G: VBGT110302-FL2 WPP20G

HC = Coated carbide  
 HE = Coated cermet  
 HW = Uncoated carbide

## Turning Insert – Positive Trigon 80°

WCGT / WCMT

Tiger-tec® Gold

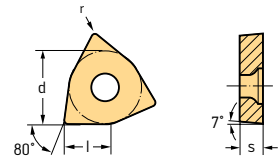

## Indexable inserts

Designation	l mm	r mm	f mm	ap mm	P			M			K	N	S				
					HC			HC			HC	HC	HC				
					WPP10G	WPP20G	WPP30G	WSM20S	WSM21	WSM30S	WKK20S	WNN10	WSM20S	WSM21	WSM30S		
WCGT020102-FN2	2,7	0,2	0,05–0,12	0,2–1,5								☺					
WCGT020104-FN2	2,7	0,4	0,08–0,20	0,2–1,5								☺					
WCGT030202-FN2	3,91	0,2	0,05–0,12	0,2–2,0								☺					
WCGT030204-FN2	3,91	0,4	0,08–0,25	0,2–2,5								☺					
WCGT040202-FN2	4,34	0,2	0,05–0,12	0,2–2,0								☺					
WCGT040204-FN2	4,34	0,4	0,08–0,25	0,2–2,5								☺					
WCGT06T304-FN2	6,52	0,4	0,08–0,25	0,2–2,5								☺					
WCGT06T308-FN2	6,52	0,8	0,10–0,30	0,3–3,0								☺					
WCGT030202-FM2	3,91	0,2	0,05–0,12	0,2–2,0					☺								☺
WCGT030204-FM2	3,91	0,4	0,08–0,25	0,2–2,5					☺								☺
WCGT040202-FM2	4,34	0,2	0,05–0,12	0,2–2,0					☺								☺
WCGT040204-FM2	4,34	0,4	0,08–0,25	0,2–2,5					☺								☺
WCMT040202-FM4	4,34	0,2	0,04–0,12	0,1–1,0				☺	☺					☺			☺
WCMT040204-FM4	4,34	0,4	0,05–0,16	0,1–1,5				☺	☺					☺			☺
WCMT06T304-FM4	6,52	0,4	0,05–0,16	0,1–1,5				☺	☺					☺			☺
WCMT06T308-FM4	6,52	0,8	0,08–0,20	0,1–1,5				☺						☺			
WCMT040202-FP4	4,34	0,2	0,04–0,12	0,1–1,0	☺	☺											
WCMT040204-FP4	4,34	0,4	0,05–0,16	0,1–1,5	☺	☺											
WCMT040208-FP4	4,34	0,8	0,08–0,20	0,1–1,5		☺											
WCMT06T302-FP4	6,52	0,2	0,04–0,12	0,1–1,0		☺											
WCMT06T304-FP4	6,52	0,4	0,05–0,16	0,1–1,5		☺											
WCMT06T308-FP4	6,52	0,8	0,08–0,20	0,1–1,5		☺											
WCMT080404-FP4	8,69	0,4	0,05–0,16	0,1–1,5		☺											
WCMT080408-FP4	8,69	0,8	0,08–0,20	0,1–1,5		☺											
WCMT040204-FP6	4,34	0,4	0,06–0,18	0,3–2,0		☺											
WCMT040208-FP6	4,34	0,8	0,10–0,20	0,5–2,0		☺											
WCGT030202-MN2	3,91	0,2	0,05–0,12	0,5–1,5									☺				
WCGT030204-MN2	3,91	0,4	0,08–0,20	0,6–1,5									☺				
WCGT040204-MN2	4,34	0,4	0,08–0,25	0,6–2,5									☺				
WCGT06T302-MN2	6,52	0,2	0,05–0,12	0,6–2,0									☺				
WCGT06T304-MN2	6,52	0,4	0,08–0,25	0,6–3,0									☺				
WCGT080404-MN2	8,69	0,4	0,08–0,25	0,6–4,0									☺				
WCGT080408-MN2	8,69	0,8	0,10–0,35	0,8–4,0									☺				
WCMT06T304-MM4	6,52	0,4	0,08–0,25	0,4–2,5				☺						☺			
WCMT06T308-MM4	6,52	0,8	0,12–0,32	0,5–2,5				☺						☺			
WCMT06T304-MP4	6,52	0,4	0,08–0,25	0,4–2,5		☺											
WCMT06T308-MP4	6,52	0,8	0,12–0,32	0,5–2,5		☺											

See the ISO 1832 designation key for dimensions

Ordering example for the grade WNN10: WCGT020102-FN2 WNN10

HC = Coated carbide

WALTER SELECT

Optimum indexable insert for → Good = ☺ → Average = ☹ → Poor = ☹☹☹ machining conditions

# Turning Insert – Positive Trigon 80°

## WCGT / WCMT

### Tiger-tec® Gold

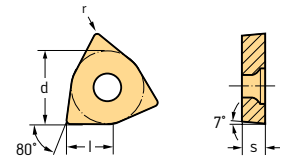

### Indexable inserts

Designation	l mm	r mm	f mm	a <sub>p</sub> mm	P			M			K	N	S		
					HC			HC			HC	HC	HC		
					WPP10G	WPP20G	WPP30G	WSM20S	WSM21	WSM30S	WKK20S	WNN10	WSM20S	WSM21	WSM30S
	WCMT030202-RM4	3,91	0,2	0,08–0,12	0,2–1,5				☺				☺		
	WCMT040202-RM4	4,34	0,2	0,08–0,12	0,4–2,0				☺	☺			☺		☺
	WCMT040204-RM4	4,34	0,4	0,12–0,25	0,4–2,5				☺	☺			☺		☺
	WCMT06T304-RM4	6,52	0,4	0,12–0,25	0,4–3,0				☺	☺			☺		☺
	WCMT06T308-RM4	6,52	0,8	0,16–0,35	0,6–3,0				☺	☺			☺		☺
	WCMT080408-RM4	8,69	0,8	0,16–0,40	0,6–4,0				☺	☺			☺		☺
	WCMT080412-RM4	8,69	1,2	0,20–0,45	0,8–4,0				☺			☺			
	WCMT030202-RP4	3,91	0,2	0,08–0,12	0,2–1,5	☺									
	WCMT040204-RP4	4,34	0,4	0,12–0,25	0,4–2,5	☺									
	WCMT06T304-RP4	6,52	0,4	0,12–0,25	0,4–3,0	☺									
	WCMT06T308-RP4	6,52	0,8	0,16–0,35	0,6–3,0	☺	☺								
	WCMT080404-RP4	8,69	0,4	0,12–0,25	0,4–3,0	☺									
	WCMT080408-RP4	8,69	0,8	0,16–0,40	0,6–4,0	☺	☺								
	WCMT080412-RP4	8,69	1,2	0,20–0,45	0,8–4,0	☺									
	WCMT040204-RK4	4,34	0,4	0,12–0,25	0,4–2,5						☺				
	WCMT06T304-RK4	6,52	0,4	0,12–0,25	0,4–3,0						☺				
	WCMT06T308-RK4	6,52	0,8	0,16–0,35	0,6–3,0						☺				
	WCMT080404-RK4	8,69	0,4	0,12–0,25	0,4–3,0						☺				
	WCMT080408-RK4	8,69	0,8	0,16–0,40	0,6–4,0						☺				
	WCMT080412-RK4	8,69	1,2	0,20–0,45	0,8–4,0						☺				

See the ISO 1832 designation key for dimensions  
 Ordering example for the grade WNN10: WCGT020102-FN2 WNN10

HC = Coated carbide

**WALTER SELECT** Optimum indexable insert for → Good = ☺ → Average = ☹ → Poor = ☹ machining conditions

☺ ☹ ☹ / ★ = New addition to the product range

# Indexable inserts copy turning system

WL...-VC...

Tiger-tec® Gold

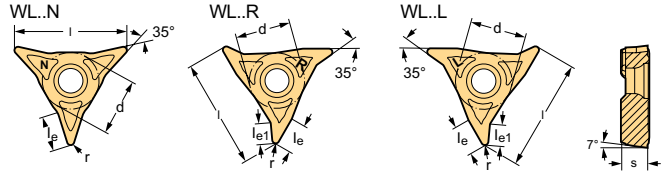

## Indexable inserts

Designation	r mm	l mm	l <sub>e</sub> mm	l <sub>e1</sub> mm	f mm	a <sub>p</sub> mm	P				M				K		S		
							HC	HC	HC	HC	HC	HC	HC	HC	HC	HC			
							WKP01G	WPP10G	WPP20G	WMP20S	WSM01	WSM10S	WMP20S	WSM20S	WKP01G	WSM01	WSM10S	WSM20S	
WL17-VC0502N-FM4	0,2	17	4,6		0,04-0,15	0,1-1,2						☺	☺	☺				☺	☺
WL17-VC0504N-FM4	0,4	17	5		0,05-0,20	0,1-1,8						☺	☺	☺				☺	☺
WL17-VC0508N-FM4	0,8	17	5,7		0,08-0,25	0,2-1,8						☺	☺	☺				☺	☺
WL25-VC0702N-FM4	0,2	25	6		0,04-0,15	0,1-2,0						☺	☺	☺				☺	☺
WL25-VC0704N-FM4	0,4	25	6,3		0,05-0,20	0,1-2,0						☺	☺	☺				☺	☺
WL25-VC0708N-FM4	0,8	25	7,1		0,08-0,25	0,2-2,0						☺	☺	☺				☺	☺
WL17-VC0502R-FM4	0,2	17	4,3	2,5	0,04-0,15	0,1-1,2						☺	☺	☺				☺	☺
WL17-VC0504R-FM4	0,4	17	4,6	3,1	0,05-0,20	0,1-1,8						☺	☺	☺				☺	☺
WL17-VC0508R-FM4	0,8	17	5	3,6	0,08-0,25	0,2-1,8						☺	☺	☺				☺	☺
WL25-VC0702R-FM4	0,2	25	5,5	3,4	0,04-0,15	0,1-2,0						☺	☺	☺				☺	☺
WL25-VC0704R-FM4	0,4	25	6,2	3,9	0,05-0,20	0,1-2,0						☺	☺	☺				☺	☺
WL25-VC0708R-FM4	0,8	25	6,6	4,6	0,08-0,25	0,2-2,0						☺	☺	☺				☺	☺
WL17-VC0502L-FM4	0,2	17	4,3	2,5	0,04-0,15	0,1-1,2						☺	☺	☺				☺	☺
WL17-VC0504L-FM4	0,4	17	4,6	3,1	0,05-0,20	0,1-1,8						☺	☺	☺				☺	☺
WL17-VC0508L-FM4	0,8	17	5	3,6	0,08-0,25	0,2-1,8						☺	☺	☺				☺	☺
WL25-VC0702L-FM4	0,2	25	5,5	3,4	0,04-0,15	0,1-2,0						☺	☺	☺				☺	☺
WL25-VC0704L-FM4	0,4	25	6,2	3,9	0,05-0,20	0,1-2,0						☺	☺	☺				☺	☺
WL25-VC0708L-FM4	0,8	25	6,6	4,6	0,08-0,25	0,2-2,0						☺	☺	☺				☺	☺
WL17-VC0504N-FP4	0,4	17	5		0,05-0,20	0,1-1,8			☺										
WL17-VC0508N-FP4	0,8	17	5,7		0,08-0,25	0,2-1,8			☺										
WL25-VC0704N-FP4	0,4	25	6,3		0,05-0,20	0,1-2,0	☺	☺	☺							☺			
WL25-VC0708N-FP4	0,8	25	7,1		0,08-0,25	0,2-2,0	☺	☺	☺							☺			
WL25-VC0704R-FP4	0,4	25	6,2	3,9	0,05-0,20	0,1-2,0	☺	☺	☺							☺			
WL25-VC0708R-FP4	0,8	25	6,6	4,6	0,08-0,25	0,2-2,0	☺	☺	☺							☺			
WL25-VC0704L-FP4	0,4	25	6,2	3,9	0,05-0,20	0,1-2,0	☺	☺	☺							☺			
WL25-VC0708L-FP4	0,8	25	6,6	4,6	0,08-0,25	0,2-2,0	☺	☺	☺							☺			
WL17-VC0504N-MM4	0,4	17	5		0,08-0,25	0,4-2,0				☺								☺	☺
WL17-VC0508N-MM4	0,8	17	5,7		0,12-0,30	0,5-2,0				☺								☺	☺
WL25-VC0704N-MM4	0,4	25	6,3		0,08-0,25	0,4-2,5				☺	☺	☺	☺	☺				☺	☺
WL25-VC0708N-MM4	0,8	25	7,1		0,12-0,32	0,5-2,5				☺	☺	☺	☺	☺				☺	☺
WL25-VC0712N-MM4	1,2	25	7,4		0,12-0,35	0,5-2,5				☺								☺	☺
WL25-VC0716N-MM4	1,6	25	8,7		0,12-0,40	0,5-2,5				☺								☺	☺
WL25-VC0704R-MM4	0,4	25	6,2	3,9	0,08-0,25	0,4-2,5				☺								☺	☺
WL25-VC0708R-MM4	0,8	25	6,6	4,6	0,12-0,32	0,5-2,5				☺								☺	☺
WL25-VC0704L-MM4	0,4	25	6,2	3,9	0,08-0,25	0,4-2,5				☺								☺	☺
WL25-VC0708L-MM4	0,8	25	6,6	4,6	0,12-0,32	0,5-2,5				☺								☺	☺

Ordering example for the grade WSM10S: WL17-VC0502N-FM4 WSM10S

HC = Coated carbide



## Indexable inserts copy turning system

WL...-VC...

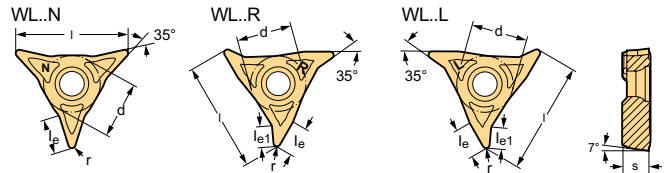
Tiger-tec® Gold



### Indexable inserts

Designation	r mm	l mm	le mm	le1 mm	f mm	ap mm	P				M			K		S	
							HC				HC			HC		HC	
							WKP01G	WPP10G	WPP20G	WMP20S	WSM01	WSM10S	WMP20S	WSM20S	WKP01G	WSM01	WSM10S
 WL17-VC0504N-MP4 WL17-VC0508N-MP4 WL25-VC0704N-MP4 WL25-VC0708N-MP4 WL25-VC0712N-MP4 WL25-VC0716N-MP4	0,4	17	5		0,08-0,25	0,4-2,0											
	0,8	17	5,7		0,12-0,30	0,5-2,0											
	0,4	25	6,3		0,08-0,25	0,4-2,5											
	0,8	25	7,1		0,12-0,32	0,5-2,5											
	1,2	25	7,4		0,12-0,35	0,5-2,5											
 WL25-VC0704R-MP4 WL25-VC0708R-MP4	0,4	25	6,2	3,9	0,08-0,25	0,4-2,5											
	0,8	25	6,6	4,6	0,12-0,32	0,5-2,5											
 WL25-VC0704L-MP4 WL25-VC0708L-MP4	0,4	25	6,2	3,9	0,08-0,25	0,4-2,5											
	0,8	25	6,6	4,6	0,12-0,32	0,5-2,5											

Ordering example for the grade WSM10S: WL17-VC0502N-FM4 WSM10S

HC = Coated carbide

## Indexable inserts copy turning system

WL...-RC...

Tiger-tec® Gold

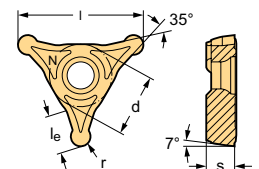

### Indexable inserts

Designation	r mm	l mm	le mm	f mm	ap mm	P		M		S	
						HC		HC		HC	
						WPP20G	WSM20S	WSM30S	WSM20S	WSM30S	
 WL25-RC0420N-MU6 WL25-RC0525N-MU6	2	25	7,2	0,12-0,40	0,5-2,0						
	2,5	25	6,9	0,12-0,45	0,5-2,5						

Ordering example for the grade WPP20G: WL25-RC0420N-MU6 WPP20G

HC = Coated carbide

WALTER SELECT





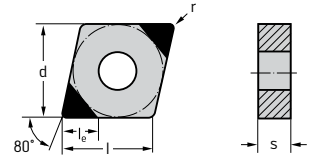

Optimum indexable insert for → Good = 😊 → Average = 😐 → Poor = ☹️ machining conditions

☺ ☹️ ☹️ / \* = New addition to the product range

## Turning Insert CBN – Negative rhombic 80° CNGA



### Indexable inserts

Designation	Number of cutting edges	$l_e$ mm	$l$ mm	$r$ mm	$f$ mm	$a_p$ mm	K		S		H					
							BH	BH	BC	BL	BH					
							WBK20	WBS10	WBH10C	WBH20C	WBH10	WBH20	WBH30			
 CNGA120404TM-MW2 CNGA120408TM-MW2 CNGA120412TM-MW2	2	2,8	12,9	0,4	0,05–0,35	0,1–1,0										
	2	2,7	12,9	0,8	0,05–0,50	0,1–1,0										
	2	2,8	12,9	1,2	0,05–0,50	0,1–1,0										
 CNGA120404EM-2 CNGA120408EM-2	2	2,8	12,9	0,4	0,05–0,20	0,1–0,5										
	2	2,7	12,9	0,8	0,05–0,25	0,1–1,0										
 CNGA120404TS-2 CNGA120408TS-2 CNGA120412TS-2	2	2,8	12,9	0,4	0,05–0,20	0,1–2,0										
	2	2,7	12,9	0,8	0,05–0,25	0,1–2,0										
	2	2,8	12,9	1,2	0,05–0,30	0,1–2,0										
 CNGA120404TM-M2 CNGA120408TM-M2 CNGA120412TM-M2	2	2,8	12,9	0,4	0,05–0,20	0,1–0,5										
	2	2,7	12,9	0,8	0,05–0,25	0,1–1,0										
	2	2,8	12,9	1,2	0,05–0,30	0,1–1,0										
 CNGA120404TM-2 CNGA120408TM-2 CNGA120412TM-2	2	2,8	12,9	0,4	0,05–0,20	0,1–1,0										
	2	2,7	12,9	0,8	0,05–0,25	0,1–1,0										
	2	2,8	12,9	1,2	0,05–0,30	0,1–1,0										
 CNGA120408TM-4	4	2,7	12,9	0,8	0,05–0,25	0,1–1,0										

See the ISO 1832 designation key for dimensions

Ordering example for the grade WBH10C: CNGA120404TM-MW2 WBH10C

BH = CBN with high CBN content

BC = coated CBN

BL = CBN with low CBN content

## Turning Insert CBN – Negative rhombic 80°CNGN

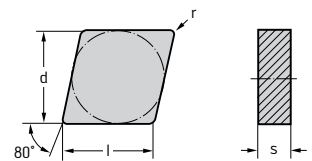

### Indexable inserts

Designation	Number of cutting edges	$l$ mm	$r$ mm	$f$ mm	$a_p$ mm	K
						BH
 CNGN120408TM-S	4	12,9	0,8	0,05–0,50	0,1–5,0	
CNGN120412TM-S	4	12,9	1,2	0,05–0,50	0,1–5,0	
CNGN120416TM-S	4	12,9	1,6	0,05–0,50	0,1–5,0	

See the ISO 1832 designation key for dimensions

Ordering example for the grade WBK30: CNGN120408TM-S WBK30

BH = CBN with high CBN content

WALTER SELECT

Optimum indexable insert for → Good = ☺ → Average = ☹ → Poor = ☹☹☹ machining conditions



# Turning Insert CBN – Negative rhombic 55° DNGA

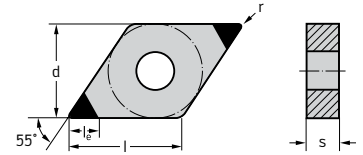

## Indexable inserts

Designation	Number of cutting edges	l <sub>e</sub> mm	l mm	r mm	f mm	a <sub>p</sub> mm	K		S		H		
							BH	BH	BC	BL	BH		
							WBK20	WBS10	WBH10C	WBH20C	WBH10	WBH20	WBH30
 DNGA150404TM-MW2 DNGA150408TM-MW2 DNGA150604TM-MW2 DNGA150612TM-MW2	2	2.9	15.5	0.4	0.05–0.20	0.1–0.5			☺				
	2	2.8	15.5	0.8	0.05–0.25	0.1–1.0			☺				
	2	2.9	15.5	0.4	0.05–0.20	0.1–0.5			☺				
	2	2.8	15.5	1.2	0.05–0.30	0.1–1.0			☺				
 DNGA150404EM-2 DNGA150408EM-2	2	2.9	15.5	0.4	0.05–0.20	0.1–0.5			☺				
	2	2.8	15.5	0.8	0.05–0.25	0.1–1.0			☺				
 DNGA150604TS-2 DNGA150608TS-2 DNGA150612TS-2	2	2.9	15.5	0.4	0.05–0.20	0.1–2.0			☺				
	2	2.8	15.5	0.8	0.05–0.25	0.1–2.0			☺				
	2	2.8	15.5	1.2	0.05–0.30	0.1–2.0			☺				
 DNGA150408TM-M2 DNGA150608TM-M2 DNGA150612TM-M2	2	2.8	15.5	0.8	0.05–0.25	0.1–1.0					☺		
	2	2.8	15.5	0.8	0.05–0.25	0.1–1.0					☺		
	2	2.8	15.5	1.2	0.05–0.30	0.1–1.0					☺		
 DNGA150404TM-2 DNGA150408TM-2 DNGA150604TM-2 DNGA150608TM-2 DNGA150612TM-2	2	2.9	15.5	0.4	0.05–0.20	0.1–0.5			☺			☺	
	2	2.8	15.5	0.8	0.05–0.25	0.1–1.0			☺		☺	☺	
	2	2.9	15.5	0.4	0.05–0.20	0.1–0.5			☺	☺	☺	☺	☺
	2	2.8	15.5	0.8	0.05–0.25	0.1–1.0			☺	☺	☺	☺	☺
	2	2.8	15.5	1.2	0.05–0.30	0.1–1.0			☺			☺	☺
 DNGA150608TM-4	4	2.8	15.5	0.8	0.05–0.25	0.1–1.0				☺			

See the ISO 1832 designation key for dimensions  
Ordering example for the grade WBH10C: DNGA150404TM-MW2 WBH10C

BH = CBN with high CBN content  
BC = coated CBN  
BL = CBN with low CBN content

# Turning Insert CBN – Negative Round RNGN

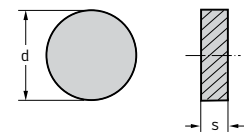

## Indexable inserts

Designation	d mm	f mm	a <sub>p</sub> mm	K	
				WBK20	WBK30
 RNGN120400TS-0	12.7	0.05–0.40	0.1–5.0	☺	

Ordering example for the grade WBK20: RNGN120400TS-0 WBK20

BH = CBN with high CBN content

### WALTER SELECT



Optimum indexable insert for → Good = ☺ → Average = ☹ → Poor = ☹ machining conditions

☺ ☹ ☹ / \* = New addition to the product range

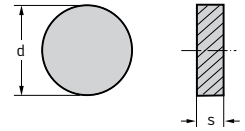
## Turning Insert CBN – Negative Round RNGN



### Indexable inserts

Designation	d mm	f mm	a <sub>p</sub> mm	K	
				BH	
				WBK20	WBK30
 RNGN120400TM-S	12,7	0,05–0,40	0,1–5,0		







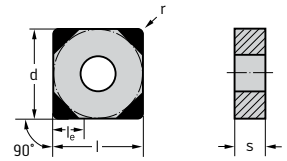



Ordering example for the grade WBK20: RNGN120400TS-0 WBK20

BH = CBN with high CBN content

## Turning Insert CBN – Negative square SNGA



### Indexable inserts

Designation	Number of cutting edges	l <sub>e</sub> mm	r mm	f mm	a <sub>p</sub> mm	K		
						BH	BL	H
						WBK20	WBH20	WBH30
 SNGA120408TS-4	4	2,8	0,8	0,05–0,30	0,1–2,0			
SNGA120412TS-4	4	2,8	1,2	0,05–0,30	0,1–2,0			
 SNGA120408TM-4	4	2,8	0,8	0,05–0,30	0,1–1,0			
SNGA120412TM-4	4	2,8	1,2	0,05–0,30	0,1–1,0			

See the ISO 1832 designation key for dimensions

Ordering example for the grade WBK20: SNGA120408TS-4 WBK20

BH = CBN with high CBN content

BL = CBN with low CBN content

## Turning Insert CBN – Negative square SNGN

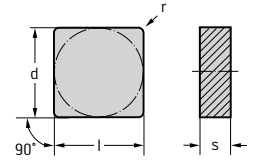

### Indexable inserts

Designation	Number of cutting edges	r mm	f mm	a <sub>p</sub> mm	Material		
					WBK30	K BH	
	SNGN120408TM-S	8	0.8	0.05–0.50	0.1–5.0		
	SNGN120412TM-S	8	1.2	0.05–0.50	0.1–5.0		
	SNGN120416TM-S	8	1.6	0.05–0.50	0.1–5.0		

Ordering example for the grade WBK30: SNGN120408TM-S WBK30

BH = CBN with high CBN content

## Turning Insert CBN – Negative triangular 60° TNGA

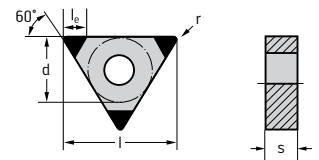

### Indexable inserts

Designation	Number of cutting edges	l <sub>e</sub> mm	r mm	f mm	a <sub>p</sub> mm	Material				
						WBK20	BH	BC	BL	BH
	TNGA160404TS-3	3	0.4	0.05–0.20	0.1–2.0					
	TNGA160408TS-3	3	0.8	0.05–0.25	0.1–2.0					
	TNGA160404TM-3	3	0.4	0.05–0.20	0.1–0.5					
	TNGA160408TM-3	3	0.8	0.05–0.25	0.1–1.0					

See the ISO 1832 designation key for dimensions

Ordering example for the grade WBK20: TNGA160404TS-3 WBK20

BH = CBN with high CBN content



BC = coated CBN

BL = CBN with low CBN content

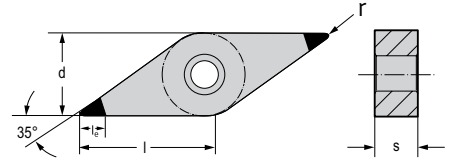
## Turning Insert CBN – Negative rhombic 35° VNGA



### Indexable inserts

Designation	Number of cutting edges	$l_e$ mm	$l$ mm	$r$ mm	$f$ mm	$a_p$ mm	K		H		
							BH	BC	BL	BH	BH
							WBK20	WBH10C	WBH10	WBH20	WBH30
 VNGA160404TS-2	2	3	16,61	0,4	0,05–0,20	0,1–2,0	☹				
VNGA160408TS-2	2	3	16,61	0,8	0,05–0,20	0,1–2,0	☹				
 VNGA160404TM-2	2	3	16,61	0,4	0,05–0,20	0,1–0,5	☺	☺	☺	☺	☺
VNGA160408TM-2	2	3	16,61	0,8	0,05–0,20	0,1–0,5	☺	☺	☺	☺	☺

See the ISO 1832 designation key for dimensions

Ordering example for the grade WBK20: VNGA160404TS-2 WBK20

BH = CBN with high CBN content



BC = coated CBN

BL = CBN with low CBN content

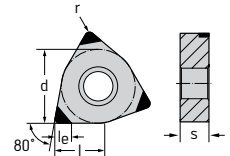
## Turning Insert CBN – Negative Trigon 80° WNGA



### Indexable inserts

Designation	Number of cutting edges	$l_e$ mm	$l$ mm	$r$ mm	$f$ mm	$a_p$ mm	K		H		
							BH	BL	BH	BH	BH
							WBK20	WBH10	WBH20	WBH30	
 WNGA080408TS-3	3	2,8	8,69	0,8	0,05–0,25	0,1–2,0	☹				
 WNGA080408TM-3	3	2,8	8,69	0,8	0,05–0,25	0,1–1,0	☺	☺	☺	☺	

See the ISO 1832 designation key for dimensions

Ordering example for the grade WBK20: WNGA080408TS-3 WBK20



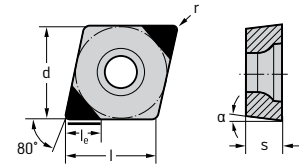

BH = CBN with high CBN content

BL = CBN with low CBN content

# Turning Insert CBN – Positive rhombic 80° CCGW



## Indexable inserts

Designation	Number of cutting edges	l <sub>e</sub> mm	l mm	r mm	α	f mm	a <sub>p</sub> mm	K		S		H		
								BH	BH	BC	BL	BH		
								WBK20	WBS10	WBH10C	WBH20C	WBH10	WBH20	WBH30
 Wiper CCGW09T304TS-MW2	2	2,8	9,67	0,4	7°	0,05–0,20	0,1–0,5			☺				
	CCGW09T308TM-MW2	2	2,7	9,67	0,8	7°	0,05–0,25	0,1–0,5			☺			
	CCGW060202EM-2	2	2,8	6,45	0,2	7°	0,05–0,15	0,1–0,3		☺				
	CCGW060204EM-2	2	2,8	6,45	0,4	7°	0,05–0,20	0,1–0,3		☺				
	CCGW09T304EM-2	2	2,8	9,67	0,4	7°	0,05–0,20	0,1–0,5		☺				
	CCGW09T308EM-2	2	2,7	9,67	0,8	7°	0,05–0,25	0,1–0,5		☺				
	CCGW060202TS-2	2	2,8	6,45	0,2	7°	0,05–0,15	0,1–0,3	☺		☺			
	CCGW060204TS-2	2	2,8	6,45	0,4	7°	0,05–0,20	0,1–0,3	☺					
	CCGW060208TS-2	2	2,7	6,45	0,8	7°	0,05–0,25	0,1–0,5	☺					
	CCGW09T304TS-2	2	2,8	9,67	0,4	7°	0,05–0,15	0,1–0,5	☺					
	CCGW09T308TS-2	2	2,7	9,67	0,8	7°	0,05–0,20	0,1–0,5	☺					
	CCGW060202TM-2	2	2,8	6,45	0,2	7°	0,05–0,15	0,1–0,3			☺			
	CCGW060204TM-2	2	2,8	6,45	0,4	7°	0,05–0,20	0,1–0,3			☺	☺	☺	☺
	CCGW060208TM-2	2	2,7	6,45	0,8	7°	0,05–0,25	0,1–0,5			☺	☺	☺	☺
	CCGW09T304TM-2	2	2,8	9,67	0,4	7°	0,05–0,20	0,1–0,5			☺	☺	☺	☺
	CCGW09T308TM-2	2	2,7	9,67	0,8	7°	0,05–0,25	0,1–0,5			☺	☺	☺	☺

See the ISO 1832 designation key for dimensions  
Ordering example for the grade WBH10C: CCGW09T304TS-MW2 WBH10C

BH = CBN with high CBN content  
BC = coated CBN  
BL = CBN with low CBN content

# Turning Insert CBN – Positive rhombic 55° DCGW

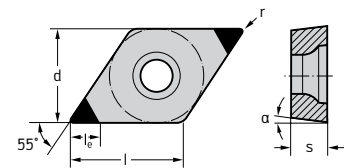

## Indexable inserts

Designation	Number of cutting edges	l <sub>e</sub> mm	l mm	r mm	α	f mm	a <sub>p</sub> mm	K		S		H		
								BH	BH	BC	BL	BH		
								WBK20	WBS10	WBH10C	WBH20C	WBH10	WBH20	WBH30
	DCGW070202EM-2	2	3	7,75	0,2	7°	0,05–0,15	0,1–0,3		☺				
	DCGW070204EM-2	2	2,9	7,75	0,4	7°	0,05–0,20	0,1–0,3		☺				
	DCGW11T304EM-2	2	2,9	11,63	0,4	7°	0,05–0,20	0,1–0,5		☺				
	DCGW11T308EM-2	2	2,8	11,63	0,8	7°	0,05–0,25	0,1–0,5		☺				

See the ISO 1832 designation key for dimensions  
Ordering example for the grade WBS10: DCGW070202EM-2 WBS10

BH = CBN with high CBN content  
BC = coated CBN  
BL = CBN with low CBN content



### WALTER SELECT

Optimum indexable insert for → Good = ☺ → Average = ☹ → Poor = ☹ machining conditions

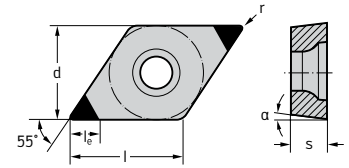
## Turning Insert CBN – Positive rhombic 55° DCGW



### Indexable inserts

Designation	Number of cutting edges	$l_e$ mm	$l$ mm	$r$ mm	$\alpha$	$f$ mm	$a_p$ mm	K		S		H		
								BH	BH	BC	BL	BL	BH	
								WBK20	WBS10	WBH10C	WBH20C	WBH10	WBH20	WBH30
 DCGW070202TS-2	2	3	7,75	0,2	7°	0,05–0,15	0,1–0,3					☺		
DCGW070204TS-2	2	2,9	7,75	0,4	7°	0,05–0,20	0,1–0,3	☺						
DCGW070208TS-2	2	2,8	7,75	0,8	7°	0,05–0,25	0,1–0,5	☺						
DCGW11T302TS-2	2	3	11,63	0,2	7°	0,05–0,15	0,1–0,5			☺	☺	☺		
DCGW11T304TS-2	2	2,9	11,63	0,4	7°	0,05–0,20	0,1–0,5	☺						
DCGW11T308TS-2	2	2,8	11,63	0,8	7°	0,05–0,25	0,1–0,5	☺						
 DCGW070202TM-2	2	3	7,75	0,2	7°	0,05–0,15	0,1–0,3						☺	
DCGW070204TM-2	2	2,9	7,75	0,4	7°	0,05–0,20	0,1–0,3				☺	☺	☺	
DCGW070208TM-2	2	2,8	7,75	0,8	7°	0,05–0,25	0,1–0,5				☺		☺	
DCGW11T302TM-2	2	3	11,63	0,2	7°	0,05–0,15	0,1–0,5					☺	☺	☺
DCGW11T304TM-2	2	2,9	11,63	0,4	7°	0,05–0,20	0,1–0,5				☺	☺	☺	☺
DCGW11T308TM-2	2	2,8	11,63	0,8	7°	0,05–0,25	0,1–0,5				☺	☺	☺	☺

See the ISO 1832 designation key for dimensions

Ordering example for the grade WBS10: DCGW070202EM-2 WBS10

BH = CBN with high CBN content

BC = coated CBN

BL = CBN with low CBN content

## Turning Insert CBN – Positive square SCGW

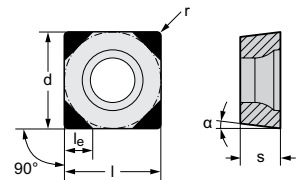

### Indexable inserts

Designation	Number of cutting edges	$l_e$ mm	$l$ mm	$r$ mm	$\alpha$	$f$ mm	$a_p$ mm	K	
								BH	WBK20
 SCGW09T304TS-4	4	2,8	9,53	0,4	7°	0,05–0,20	0,1–0,5		☺
SCGW09T308TS-4	4	2,8	9,53	0,8	7°	0,05–0,25	0,1–0,5		☺

Ordering example for the grade WBK20: SCGW09T304TS-4 WBK20

BH = CBN with high CBN content

## Turning Insert CBN – Positive triangular 60° TCGW

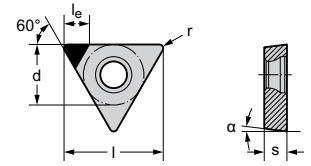

### Indexable inserts

Designation	Number of cutting edges	le mm	l mm	r mm	α	f mm	ap mm	K			H		
								BH	BC	BL	BH	BL	BL
 TCGW06T102TS-1 TCGW06T104TS-1	1	2,4	6,87	0,2	7°	0,02–0,12	0,1–0,3	WBK20			WBH10		WBH20
	1	2,2	6,87	0,4	7°	0,02–0,12	0,1–0,3	WBK20			WBH10		WBH20



See the ISO 1832 designation key for dimensions  
Ordering example for the grade WBH10: TCGW06T102TS-1 WBH10

BH = CBN with high CBN content  
BL = CBN with low CBN content

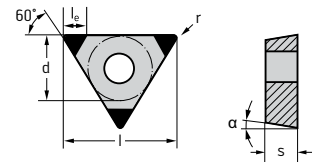
## Turning Insert CBN – Positive triangular 60° TCGW



### Indexable inserts

Designation	Number of cutting edges	le mm	l mm	r mm	α	f mm	ap mm	K			H			
								BH	BC	BL	BH	BL	BH	BH
 TCGW110202TS-3 TCGW110204TS-3	3	2,8	11	0,2	7°	0,05–0,15	0,1–0,3	WBK20						
	3	3,1	11	0,4	7°	0,05–0,20	0,1–0,3	WBK20						
 TCGW110204TM-3 TCGW110208TM-3	3	3,1	11	0,4	7°	0,05–0,20	0,1–0,3	WBK20						
	3	2,8	11	0,8	7°	0,05–0,25	0,1–0,5	WBK20						

See the ISO 1832 designation key for dimensions  
Ordering example for the grade WBK20: TCGW110202TS-3 WBK20





BH = CBN with high CBN content  
BC = coated CBN  
BL = CBN with low CBN content

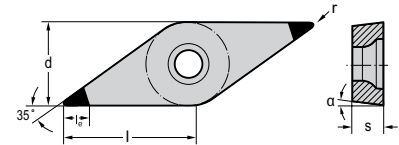

## Turning Insert CBN – Positive rhombic 35° VBGW

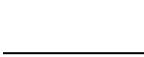
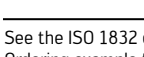

### Indexable inserts

Designation	Number of cutting edges	l <sub>e</sub> mm	l mm	r mm	α	f mm	a <sub>p</sub> mm	H			
								BC	BL	BH	
 VBGW160404TS-2	2	3	16,61	0,4	5°	0,05–0,20	0,1–0,5	☺	☺	☺	☺
 VBGW160408TS-2	2	3	16,61	0,8	5°	0,05–0,25	0,1–0,5	☺	☺	☺	☺
 VBGW110304TM-2	2	3	11,07	0,4	5°	0,05–0,20	0,1–0,5	☺	☺	☺	☺
 VBGW160402TM-2	2	3,4	16,61	0,2	5°	0,05–0,25	0,1–0,5	☺	☺	☺	☺
 VBGW160404TM-2	2	3	16,61	0,4	5°	0,05–0,20	0,1–0,5	☺	☺	☺	☺
 VBGW160408TM-2	2	3	16,61	0,8	5°	0,05–0,25	0,1–0,5	☺	☺	☺	☺

See the ISO 1832 designation key for dimensions

Ordering example for the grade WBH10: VBGW160404TS-2 WBH10

BC = coated CBN







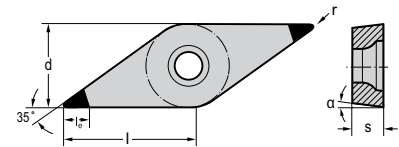

BL = CBN with low CBN content

BH = CBN with high CBN content

## Turning Insert CBN – Positive rhombic 35° VCGW



### Indexable inserts

Designation	Number of cutting edges	l <sub>e</sub> mm	l mm	r mm	α	f mm	a <sub>p</sub> mm	S			H	
								WBS10	WBH20C	WBH10	BH	BC
 VCGW110302EM-2	2	3,4	11,07	0,2	7°	0,05–0,15	0,1–0,3	☺	☺	☺	☺	☺
 VCGW110304EM-2	2	3	11,07	0,4	7°	0,05–0,20	0,1–0,3	☺	☺	☺	☺	☺
 VCGW160404EM-2	2	3	16,61	0,4	7°	0,05–0,20	0,1–0,5	☺	☺	☺	☺	☺
 VCGW160408EM-2	2	3	16,61	0,8	7°	0,05–0,25	0,1–0,5	☺	☺	☺	☺	☺
 VCGW110302TS-2	2	3,4	11,07	0,2	7°	0,05–0,15	0,1–0,3	☺	☺	☺	☺	☺
 VCGW160404TS-2	2	3	16,61	0,4	7°	0,05–0,20	0,1–0,5	☺	☺	☺	☺	☺
 VCGW160408TS-2	2	3	16,61	0,8	7°	0,05–0,25	0,1–0,5	☺	☺	☺	☺	☺
 VCGW160404TM-2	2	3	16,61	0,4	7°	0,05–0,20	0,1–0,5	☺	☺	☺	☺	☺
 VCGW160408TM-2	2	3	16,61	0,8	7°	0,05–0,25	0,1–0,5	☺	☺	☺	☺	☺

See the ISO 1832 designation key for dimensions

Ordering example for the grade WBS10: VCGW110302EM-2 WBS10

BH = CBN with high CBN content



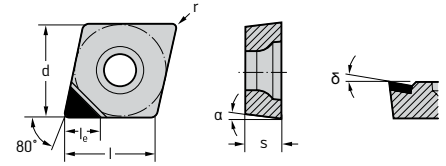

BC = coated CBN

BL = CBN with low CBN content

# Turning Insert PCD – Positive rhombic 80° CCGT / CCGW



## Indexable inserts

Designation	Number of cutting edges	l <sub>e</sub> mm	l mm	r mm	α	f mm	a <sub>p</sub> mm	N			
								DP	DP		
 Chipbreaker	CCGT060204FS-M1	1	3,5	6,45	0,4	7°	25°	0,08–0,20	0,1–2,0	☺	☺
	CCGT09T304FS-M1	1	4	9,67	0,4	7°	25°	0,08–0,20	0,1–2,0	☺	☺
	CCGT060202FS-1	1	3,5	6,45	0,2	7°	7°	0,03–0,12	0,1–3,0	☺	☺
	CCGT060204FS-1	1	3,5	6,45	0,4	7°	7°	0,03–0,25	0,1–3,0	☺	☺
	CCGT060208FS-1	1	3,5	6,45	0,8	7°	7°	0,03–0,38	0,1–3,0	☺	☺
	CCGT09T304FS-1	1	4	9,67	0,4	7°	10°	0,03–0,25	0,1–3,5	☺	☺
	CCGT09T308FS-1	1	4	9,67	0,8	7°	10°	0,03–0,38	0,1–3,5	☺	☺
	CCGW060202FS-1	1	3,6	6,45	0,2	7°	0°	0,03–0,12	0,1–3,0	☺	☺
	CCGW060204FS-1	1	3,5	6,45	0,4	7°	0°	0,03–0,25	0,1–3,0	☺	☺
	CCGW060208FS-1	1	3,5	6,45	0,8	7°	0°	0,03–0,38	0,1–3,0	☺	☺
	CCGW09T302FS-1	1	4,1	9,67	0,2	7°	0°	0,03–0,12	0,1–3,5	☺	☺
	CCGW09T304FS-1	1	4,1	9,67	0,4	7°	0°	0,03–0,25	0,1–3,5	☺	☺
	CCGW09T308FS-1	1	4	9,67	0,8	7°	0°	0,03–0,38	0,1–3,5	☺	☺
	CCGW120404FS-1	1	4,1	12,9	0,4	7°	0°	0,03–0,25	0,1–3,5	☺	☺
	CCGW120408FS-1	1	4	12,9	0,8	7°	0°	0,03–0,38	0,1–3,5	☺	☺
		CCGW060204FSL-9	1	6,4	6,45	0,4	7°	0°	0,03–0,25	0,1–6,4	☺
CCGW09T304FSL-9		1	9,7	9,67	0,4	7°	0°	0,03–0,25	0,1–9,7	☺	☺
CCGW09T308FSL-9		1	9,7	9,67	0,8	7°	0°	0,03–0,38	0,1–9,7	☺	☺
	CCGW060204FSR-9	1	6,4	6,45	0,4	7°	0°	0,03–0,25	0,1–6,4	☺	☺
	CCGW09T304FSR-9	1	9,7	9,67	0,4	7°	0°	0,03–0,25	0,1–9,7	☺	☺
	CCGW09T308FSR-9	1	9,7	9,67	0,8	7°	0°	0,03–0,38	0,1–9,7	☺	☺

See the ISO 1832 designation key for dimensions  
Ordering example for the grade WDN10: CCGT060204FS-M1 WDN10

DP = Polycrystalline diamond

## Turning Insert PCD – Positive rhombic 80° CPGW

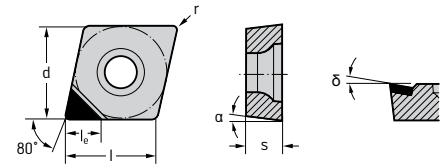

### Indexable inserts

Designation	Number of cutting edges	l <sub>e</sub> mm	l mm	r mm	α	f mm	a <sub>p</sub> mm	N	
								WDN10	WDN10
 CPGW050204FS-1	1	3	5,64	0,4	11°	0°	0,03–0,25	0,1–2,5	☺
CPGW060204FS-1	1	3,5	6,45	0,4	11°	0°	0,03–0,25	0,1–3,0	☺
CPGW09T304FS-1	1	4	9,67	0,4	11°	0°	0,03–0,25	0,1–3,5	☺
CPGW09T308FS-1	1	4	9,67	0,8	11°	0°	0,03–0,38	0,1–3,5	☺
CPGW120408FS-1	1	4	12,9	0,8	11°	0°	0,03–0,38	0,1–3,5	☺

See the ISO 1832 designation key for dimensions







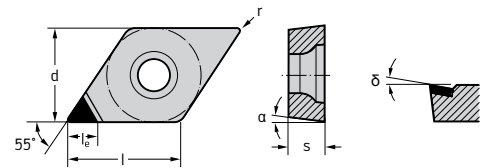



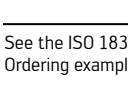

DP = Polycrystalline diamond

Ordering example for the grade WDN10: CPGW050204FS-1 WDN10

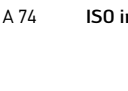
## Turning Insert PCD – Positive rhombic 55° DCGT / DCGW

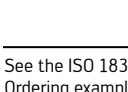

### Indexable inserts

Designation	Number of cutting edges	l <sub>e</sub> mm	l mm	r mm	α	f mm	a <sub>p</sub> mm	N	
								WDN10	WDN10
 DCGT070204FS-M1	1	3,5	7,75	0,4	7°	25°	0,08–0,20	0,1–2,0	☺
 DCGT11T304FS-M1	1	4	11,63	0,4	7°	25°	0,08–0,20	0,1–2,0	☺
 DCGT070202FS-1	1	3,7	7,75	0,2	7°	7°	0,03–0,12	0,1–3,0	☺
 DCGT070204FS-1	1	3,5	7,75	0,4	7°	7°	0,03–0,25	0,1–3,0	☺
 DCGT070208FS-1	1	3,5	7,75	0,8	7°	7°	0,03–0,38	0,1–3,0	☺
 DCGT11T302FS-1	1	4,2	11,63	0,2	7°	10°	0,03–0,12	0,1–3,5	☺
 DCGT11T304FS-1	1	4	11,63	0,4	7°	10°	0,03–0,25	0,1–3,0	☺
 DCGT11T308FS-1	1	4	11,63	0,8	7°	10°	0,03–0,38	0,1–3,5	☺
 DCGW070202FS-1	1	3,7	7,75	0,2	7°	0°	0,03–0,12	0,1–3,0	☺
 DCGW070204FS-1	1	3,5	7,75	0,4	7°	0°	0,03–0,25	0,1–3,0	☺
 DCGW11T302FS-1	1	4,2	11,63	0,2	7°	0°	0,03–0,12	0,1–3,5	☺
 DCGW11T304FS-1	1	4	11,63	0,4	7°	0°	0,03–0,25	0,1–3,5	☺
 DCGW11T308FS-1	1	4	11,63	0,8	7°	0°	0,03–0,38	0,1–3,5	☺

See the ISO 1832 designation key for dimensions

DP = Polycrystalline diamond

Ordering example for the grade WDN10: DCGT070204FS-M1 WDN10

## Turning Insert PCD – Positive rhombic 55° DPGW

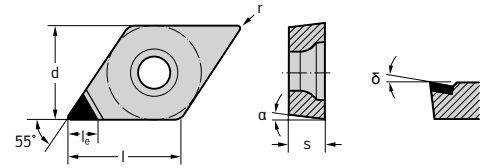

### Indexable inserts

Designation	Number of cutting edges	l <sub>e</sub> mm	l mm	r mm	α	f mm	a <sub>p</sub> mm	Material	
								WDN10	WDN10
 DPGW070204FS-1	1	3,5	7,75	0,4	11°	0°	0,03–0,25	0,1–3,0	N DP
DPGW11T304FS-1	1	4	11,63	0,4	11°	0°	0,03–0,25	0,1–3,5	☺ ☺
DPGW11T308FS-1	1	4	11,63	0,8	11°	0°	0,03–0,38	0,1–3,5	☺ ☺

See the ISO 1832 designation key for dimensions  
Ordering example for the grade WDN10: DPGW070204FS-1 WDN10

DP = Polycrystalline diamond

## Turning Insert PCD – Positive square SCGW

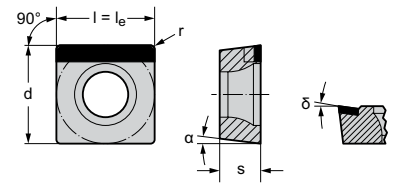

### Indexable inserts

Designation	Number of cutting edges	l <sub>e</sub> mm	l mm	r mm	α	f mm	a <sub>p</sub> mm	Material	
								WDN10	WDN10
 SCGW09T304FS-9	1	9,5	9,53	0,4	7°	0°	0,03–0,25	0,1–9,5	☺ ☺

See the ISO 1832 designation key for dimensions  
Ordering example for the grade WDN10: SCGW09T304FS-9 WDN10

DP = Polycrystalline diamond

**WALTER SELECT** Optimum indexable insert for → Good = ☺ → Average = ☹ → Poor = ☹ machining conditions

## Turning Insert PCD – Positive square SPGW

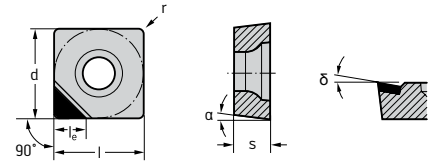

### Indexable inserts

Designation	Number of cutting edges	$l_e$ mm	$l$ mm	$r$ mm	$\alpha$	$f$ mm	$a_p$ mm	N	O	
								DP	DP	
								WDN10	WDN10	
 SPGW09T308FS-1	1	4	9,53	0,8	11°	0°	0,03–0,38	0,1–3,5	☺	☺

See the ISO 1832 designation key for dimensions



Ordering example for the grade WDN10: SPGW09T308FS-1 WDN10

DP = Polycrystalline diamond

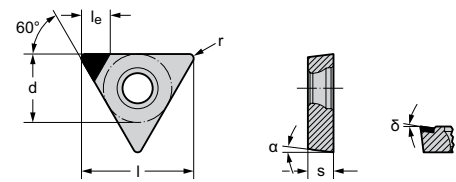
## Turning Insert PCD – Positive triangular 60°TCGW



### Indexable inserts

Designation	Number of cutting edges	$l_e$ mm	$l$ mm	$r$ mm	$\alpha$	$f$ mm	$a_p$ mm	N	O	
								DP	DP	
								WDN10	WDN10	
 TCGW090204FS-1	1	3,8	9,62	0,4	7°	0°	0,03–0,25	0,1–3,0	☺	☺
TCGW110202FS-1	1	4,4	11	0,2	7°	0°	0,03–0,12	0,1–3,0	☺	☺
TCGW110204FS-1	1	4,3	11	0,4	7°	0°	0,03–0,25	0,1–3,0	☺	☺
TCGW110208FS-1	1	4	11	0,8	7°	0°	0,03–0,38	0,1–3,0	☺	☺
TCGW16T304FS-1	1	4,3	16,5	0,4	7°	0°	0,03–0,25	0,1–3,5	☺	☺
TCGW16T308FS-1	1	4	16,5	0,8	7°	0°	0,03–0,38	0,1–3,5	☺	☺
 TCGW090204FS-9	1	9	9,62	0,4	7°	0°	0,03–0,25	0,1–9,0	☺	☺
TCGW110204FS-9	1	10,4	11	0,4	7°	0°	0,03–0,25	0,1–10,4	☺	☺
TCGW16T308FS-9	1	15,3	16,5	0,8	7°	0°	0,03–0,38	0,1–15,3	☺	☺

See the ISO 1832 designation key for dimensions

Ordering example for the grade WDN10: TCGW090204FS-1 WDN10

DP = Polycrystalline diamond

## Turning Insert PCD – Positive triangular 60° TPGW

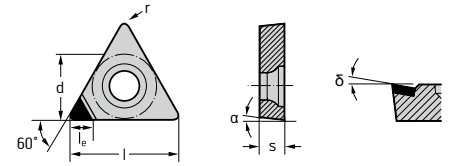

### Indexable inserts

Designation	Number of cutting edges	l <sub>e</sub> mm	l mm	r mm	α	f mm	a <sub>p</sub> mm	N			
								DP	DP		
								WDN10	WDN10		
	TPGW110204FS-1	1	4,2	11	0,4	11°	0°	0,03–0,25	0,1–3,5	☺	☺
	TPGW16T304FS-1	1	4,2	16,5	0,4	11°	0°	0,03–0,25	0,1–3,5	☺	☺
	TPGW16T308FS-1	1	4	16,5	0,8	11°	0°	0,03–0,38	0,1–3,5	☺	☺

See the ISO 1832 designation key for dimensions  
Ordering example for the grade WDN10: TPGW110204FS-1 WDN10

DP = Polycrystalline diamond

## Turning Insert PCD – Positive rhombic 35° VCGT / VCGW

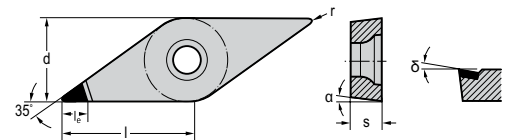

### Indexable inserts

Designation	Number of cutting edges	l <sub>e</sub> mm	l mm	r mm	α	f mm	a <sub>p</sub> mm	N			
								DP	DP		
								WDN10	WDN10		
	VCGT110302FS-1	1	4,1	11,07	0,2	7°	10°	0,03–0,12	0,1–3,0	☺	☺
	VCGT110304FS-1	1	3,7	11,07	0,4	7°	10°	0,03–0,25	0,1–3,0	☺	☺
	VCGT160404FS-1	1	4,5	16,61	0,4	7°	10°	0,03–0,25	0,1–4,0	☺	☺
	VCGT160408FS-1	1	4,5	16,61	0,8	7°	10°	0,03–0,38	0,1–4,0	☺	☺
	VCGW110302FS-1	1	4,1	11,07	0,2	7°	0°	0,03–0,12	0,1–3,0	☺	☺
	VCGW110304FS-1	1	3,7	11,07	0,4	7°	0°	0,03–0,25	0,1–3,0	☺	☺
	VCGW110308FS-1	1	3,7	11,07	0,8	7°	0°	0,03–0,38	0,1–3,0	☺	☺
	VCGW160404FS-1	1	4,5	16,61	0,4	7°	0°	0,03–0,25	0,1–4,0	☺	☺
	VCGW160408FS-1	1	4,5	16,61	0,8	7°	0°	0,03–0,38	0,1–4,0	☺	☺

See the ISO 1832 designation key for dimensions  
Ordering example for the grade WDN10: VCGT110302FS-1 WDN10

DP = Polycrystalline diamond

**WALTER SELECT** Optimum indexable insert for → Good = ☺ → Average = ☹ → Poor = ☹ machining conditions

## Turning Insert Ceramic – Negative rhombic 80° CNGN / CNGA

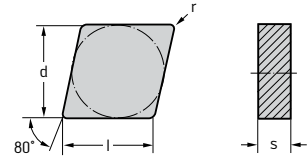

### Indexable inserts

Designation	l mm	r mm	f mm	a <sub>p</sub> mm	K		S		H
					CN	CS	CR	CC	
					WCK10	WS10	WS30	WWS20	WCH10C
	CNGN120408T01020	12,9	0,8	0,10–0,22	0,1–3,6				
	CNGN120412T01020	12,9	1,2	0,10–0,32	0,1–3,6				
	CNGN120708T01020	12,9	0,8	0,10–0,22	0,1–3,6				
	CNGN120712T01020	12,9	1,2	0,10–0,32	0,1–3,6				
	CNGN120716T01020	12,9	1,6	0,10–0,42	0,1–3,6				
	CNGN120712T02020	12,9	1,2	0,10–0,60	0,1–6,0				
	CNGA120404SM-MWS	12,9	0,4	0,05–0,25	0,1–0,5				
	CNGA120408SM-MWS	12,9	0,8	0,05–0,30	0,1–1,0				
	CNGA120412SM-MWS	12,9	1,2	0,05–0,35	0,1–1,0				
	CNGA120404SM-S	12,9	0,4	0,05–0,20	0,1–0,5				
	CNGA120408SM-S	12,9	0,8	0,05–0,25	0,1–1,0				
	CNGA120412SM-S	12,9	1,2	0,05–0,30	0,1–1,0				
	CNGA120408T02020	12,9	0,8	0,10–0,40	0,1–6,0				
	CNGA120412T02020	12,9	1,2	0,10–0,60	0,1–6,0				
	CNGA120416T02020	12,9	1,6	0,10–0,60	0,1–6,0				

See the ISO 1832 designation key for dimensions

Ordering example for the grade WWS20: CNGN120408T01020 WWS20

CN = Silicon nitride Si<sub>3</sub>N<sub>4</sub>

CS = Uncoated ceramic SiAlON

CR = Reinforced ceramic

CC = Coated ceramic

## Turning Insert Ceramic – Negative rhombic 55° DNGA

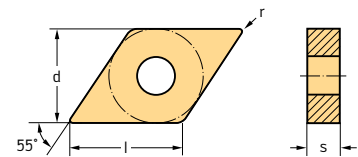

### Indexable inserts

Designation	l mm	r mm	f mm	a <sub>p</sub> mm	K		H
					CN	CC	
					WCK10	WCH10C	
	DNGA150404SM-S	15,5	0,4	0,05–0,20	0,1–0,5		
	DNGA150408SM-S	15,5	0,8	0,05–0,25	0,1–1,0		
	DNGA150604SM-S	15,5	0,4	0,05–0,20	0,1–0,5		
	DNGA150608SM-S	15,5	0,8	0,05–0,25	0,1–1,0		

See the ISO 1832 designation key for dimensions

Ordering example for the grade WCH10C: DNGA150404SM-S WCH10C

CN = Silicon nitride Si<sub>3</sub>N<sub>4</sub>

CC = Coated ceramic

WALTER SELECT

Optimum indexable insert for → Good = ☺ → Average = ☹ → Poor = ☹ machining conditions



## Turning Insert Ceramic – Negative rhombic 55° DNGA

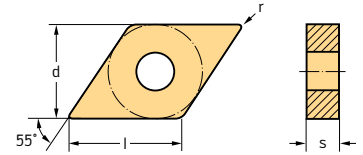

### Indexable inserts

Designation	l mm	r mm	f mm	a <sub>p</sub> mm	Material	
					K	H
 DNGA150608T02020 DNGA150612T02020	15,5	0,8	0,10–0,40	0,1–5,0	WCK10	WCH10C
	15,5	1,2	0,10–0,60	0,1–5,0	☺	☺

See the ISO 1832 designation key for dimensions  
Ordering example for the grade WCH10C: DNGA150404SM-S WCH10C

CN = Silicon nitride Si<sub>3</sub>N<sub>4</sub>  
CC = Coated ceramic

## Turning Insert Ceramic – Negative round RNGN

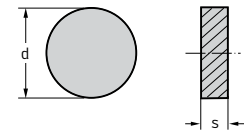

### Indexable inserts

Designation	d mm	f mm	a <sub>p</sub> mm	Material		
				S	CS	CR
 RNGN120700E RNGN120700T01020	12,7	0,10–0,32	0,1–3,6	WIS10	WIS30	WWS20
	12,7	0,20–0,32	0,2–3,6	☺	☺	☺
 RNGN150700T01020	15,875	0,10–0,40	0,2–4,5			☺

See the ISO 1832 designation key for dimensions  
Ordering example for the grade WIS10: RNGN120700E WIS10



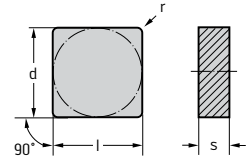

CS = Uncoated ceramic SiAlON  
CR = Reinforced ceramic

**WALTER SELECT** Optimum indexable insert for → Good = ☺ → Average = ☹ → Poor = ☹ machining conditions

## Turning Insert Ceramic – Negative square SNGN / SNGA



### Indexable inserts

Designation	r mm	f mm	a <sub>p</sub> mm	K		S		H	
				CN	CS	CR	CC		
 SNGN120708T01020 SNGN120712T01020	0.8	0.10–0.22	0.1–3.6	WCK10	WIS10	WWS20	WCH10C		
	1.2	0.10–0.32	0.1–3.6	☺	☺				
 SNGN120412T02020 SNGN120416T02020 SNGN120712T02020 SNGN120716T02020	1.2	0.10–0.60	0.1–5.0	☺					
	1.6	0.10–0.60	0.1–5.0	☺					
	1.2	0.10–0.60	0.1–5.0	☺					
	1.6	0.10–0.60	0.1–5.0	☺					
 SNGA120408SM-S SNGA120412SM-S	0.8	0.05–0.30	0.1–1.0					☺	
	1.2	0.05–0.30	0.1–1.0					☺	
 SNGA120408T02020 SNGA120412T02020 SNGA120416T02020	0.8	0.10–0.40	0.1–5.0	☺					
	1.2	0.10–0.60	0.1–5.0	☺					
	1.6	0.10–0.80	0.1–5.0	☺					



See the ISO 1832 designation key for dimensions  
Ordering example for the grade WWS20: SNGN120708T01020 WWS20

CN = Silicon nitride Si<sub>3</sub>N<sub>4</sub>  
CS = Uncoated ceramic SiAlON  
CR = Reinforced ceramic  
CC = Coated ceramic

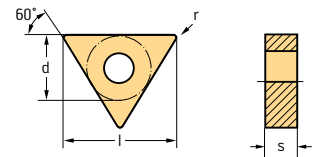
## Turning Insert Ceramic – Negative triangular 60° TNGA



### Indexable inserts

Designation	r mm	f mm	a <sub>p</sub> mm	K		H	
				CN	CC		
 TNGA160404SM-S TNGA160408SM-S	0.4	0.05–0.20	0.1–0.5				☺
	0.8	0.05–0.25	0.1–1.0				☺
 TNGA160408T02020 TNGA160412T02020	0.8	0.10–0.40	0.1–5.0	☺			
	1.2	0.10–0.60	0.1–5.0	☺			

See the ISO 1832 designation key for dimensions  
Ordering example for the grade WCH10C: TNGA160404SM-S WCH10C

CN = Silicon nitride Si<sub>3</sub>N<sub>4</sub>  
CC = Coated ceramic

## Turning Insert Ceramic – Negative rhombic 35° VNGA

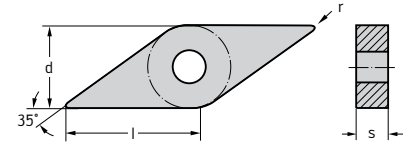

### Indexable inserts

Designation	l mm	r mm	f mm	a <sub>p</sub> mm	Material	
					WCK10	WCH10C
 VNGA160404SM-S	16,61	0,4	0,05–0,20	0,1–0,5	☺	☺
VNGA160408SM-S	16,61	0,8	0,05–0,23	0,1–0,5	☺	☺



See the ISO 1832 designation key for dimensions  
Ordering example for the grade WCH10C: VNGA160404SM-S WCH10C

CC = Coated ceramic

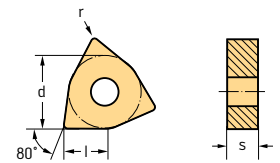
## Turning Insert Ceramic – Negative Trigon 80° WNGA



### Indexable inserts

Designation	l mm	r mm	f mm	a <sub>p</sub> mm	Material	
					WCK10	WCH10C
 WNGA080404SM-S	8,69	0,4	0,05–0,20	0,1–0,5	☺	☺
WNGA080408SM-S	8,69	0,8	0,05–0,25	0,1–1,0	☺	☺
 WNGA080408T02020	8,69	0,8	0,10–0,40	0,1–5,0	☺	☺
WNGA080412T02020	8,69	1,2	0,10–0,60	0,1–5,0	☺	☺

See the ISO 1832 designation key for dimensions  
Ordering example for the grade WCH10C: WNGA080404SM-S WCH10C



CN = Silicon nitride Si<sub>3</sub>N<sub>4</sub>  
CC = Coated ceramic

**WALTER SELECT** Optimum indexable insert for → Good = ☺ → Average = ☹ → Poor = ☹ machining conditions

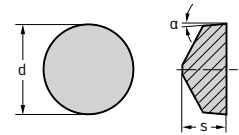
## Turning Insert Ceramic – Positive round RCGX



### Indexable inserts

Designation	d mm	α	f mm	a <sub>p</sub> mm	S		
					WIS10	CS	CR
 RCGX060600E RCGX090700E RCGX120700E	6,35	7°	0,10–0,15	0,1–1,8	☹	☹	☹
	9,525	7°	0,10–0,25	0,1–2,4	☹	☹	☹
	12,7	7°	0,10–0,32	0,1–3,6	☹	☹	☹
 RCGX060600T01020 RCGX090700T01020 RCGX120700T01020	6,35	7°	0,10–0,20	0,2–1,8	☹	☹	☹
	9,525	7°	0,10–0,25	0,2–2,4	☹	☹	☹
	12,7	7°	0,10–0,32	0,2–3,6	☹	☹	☹



See the ISO 1832 designation key for dimensions  
Ordering example for the grade WIS30: RCGX060600E WIS30

CS = Uncoated ceramic SiAlON  
CR = Reinforced ceramic

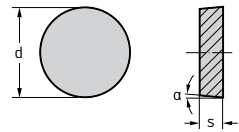
## Turning Insert Ceramic – Positive round RPGN



### Indexable inserts

Designation	d mm	α	f mm	a <sub>p</sub> mm	S	
					WIS10	CS
 RPGN090300E RPGN120400E	9,525	11°	0,10–0,20	0,1–2,4	☹	☹
	12,7	11°	0,10–0,30	0,1–3,6	☹	☹
 RPGN090300T01020 RPGN120400T01020	9,525	11°	0,10–0,25	0,2–2,4	☹	☹
	12,7	11°	0,10–0,32	0,2–3,6	☹	☹

See the ISO 1832 designation key for dimensions  
Ordering example for the grade WIS10: RPGN090300E WIS10



CS = Uncoated ceramic SiAlON

### CBN – Indexable inserts copy turning system

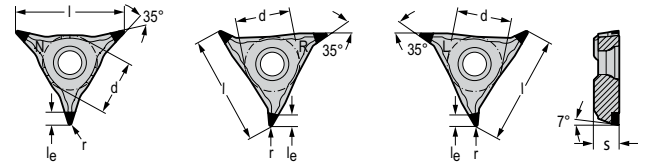
#### WL...-VC...



### Indexable inserts

Designation	Number of cutting edges	r mm	l mm	le mm	f mm	ap mm	H	
							BC	WBH20C
 WL25-VC0704NTM-3 WL25-VC0708NTM-3	3	0,4	25	3	0,05–0,20	0,1–0,5	BC	WBH20C
	3	0,8	25	3	0,05–0,25	0,1–0,5	BC	WBH20C
 WL25-VC0704RTM-3 WL25-VC0708RTM-3	3	0,4	25	3	0,05–0,20	0,1–0,5	BC	WBH20C
	3	0,8	25	3	0,05–0,25	0,1–0,5	BC	WBH20C
 WL25-VC0704LTM-3 WL25-VC0708LTM-3	3	0,4	25	3	0,05–0,20	0,1–0,5	BC	WBH20C
	3	0,8	25	3	0,05–0,25	0,1–0,5	BC	WBH20C

Ordering example for the grade WBH20C: WL25-VC0704NTM-3 WBH20C

BC = coated CBN

### CBN – Indexable inserts copy turning system

#### WL...-RC...

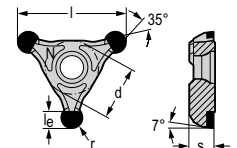

### Indexable inserts

Designation	Number of cutting edges	r mm	l mm	le mm	f mm	ap mm	H	
							BC	WBH20C
 WL25-RC0420NTM-3 WL25-RC0525NTM-3	3	2	25	3,2	0,02–0,50	0,1–2,0	BC	WBH20C
	3	2,5	25	5	0,02–0,50	0,1–2,5	BC	WBH20C

Ordering example for the grade WBH20C: WL25-RC0420NTM-3 WBH20C

BC = coated CBN

**WALTER SELECT** Optimum indexable insert for → Good = ☺ → Average = ☹ → Poor = ☹ machining conditions

## Square-shank turning toolholders – Negative basic shape

Type				
Machining				
Designation	<b>DCLN</b>	<b>DCLN...-P</b>	<b>PCLN</b>	<b>DCBN</b>
Approach angle	95°	95°	95°	75°
Clamping system	Claw	Claw	Lever-type	Claw
Coolant supply	External	Precision cooling	External	External
Shank size h [mm]	16–32	20–32	16–50	25–32
Shank size h [Inch]	0,625–1,500	0,750–1,000		
Insert size l [mm]	9–19	12–16	9–25	12–19
Page in catalogue	A 105	A 105	A 110	A 112
QR code				
	<a href="http://www.walter-tools.com/woc/">www.walter-tools.com/woc/</a> DCLN	<a href="http://www.walter-tools.com/woc/">www.walter-tools.com/woc/</a> DCLN-P	<a href="http://www.walter-tools.com/woc/">www.walter-tools.com/woc/</a> PCLN	<a href="http://www.walter-tools.com/woc/">www.walter-tools.com/woc/</a> DCBN

Type				
Machining				
Designation	<b>DCKN</b>	<b>DCRN</b>	<b>PCBN</b>	<b>PCKN</b>
Approach angle	75°	75°	75°	75°
Clamping system	Claw	Claw	Lever-type	Lever-type
Coolant supply	External	External	External	External
Shank size h [mm]	25–32	25–32	25–32	25
Shank size h [Inch]	1,000–1,250	1,000–1,250		
Insert size l [mm]	12–16	12–19	12–19	12
Page in catalogue	A 115	A 113	A 114	A 117
QR code				
	<a href="http://www.walter-tools.com/woc/">www.walter-tools.com/woc/</a> DCKN	<a href="http://www.walter-tools.com/woc/">www.walter-tools.com/woc/</a> DCRN	<a href="http://www.walter-tools.com/woc/">www.walter-tools.com/woc/</a> PCBN	<a href="http://www.walter-tools.com/woc/">www.walter-tools.com/woc/</a> PCKN

## Square-shank turning toolholders – Negative basic shape

Type				
Machining				
Designation	PCSN	DDHN	DDQN	DDJN
Approach angle	45°	107,5°	107,5°	93°
Clamping system	Lever-type	Claw	Claw	Claw
Coolant supply	External	External	External	External
Shank size h [mm]	25	20–25		20–32
Shank size h [Inch]			1,000–1,250	0,625–1,500
Insert size l [mm]	12	15	15	11–15
Page in catalogue	A 118	A 119	A 120	A 121
QR code				
	<a href="http://www.walter-tools.com/woc/">www.walter-tools.com/woc/</a>	PCSN	DDHN	DDQN

Type				
Machining				
Designation	DDJN...-P	PDJN	DDNN	DDPN
Approach angle	93°	93°	62,5°	62,5°
Clamping system	Claw	Lever-type	Claw	Claw
Coolant supply	Precision cooling	External	External	External
Shank size h [mm]	20–25	16–32	20–32	
Shank size h [Inch]	0,750–1,000			0,750–1,250
Insert size l [mm]	11–15	11–15	11–15	15
Page in catalogue	A 121	A 127	A 128	A 126
QR code				
	<a href="http://www.walter-tools.com/woc/">www.walter-tools.com/woc/</a>	DDJN-P	PDJN	DDNN



## Square-shank turning toolholders – Negative basic shape

Type				
Machining				
Designation	DSBN	DSKN	DSRN	DSBN...-P
Approach angle	75°	75°	75°	75°
Clamping system	Claw	Claw	Claw	Claw
Coolant supply	External	External	External	Precision cooling
Shank size h [mm]	25–40	25–32		25
Shank size h [Inch]			0,750–1,500	
Insert size l [mm]	12–19	12–15	12–25	12
Page in catalogue	A 129	A 133	A 131	A 129
QR code				
	<a href="http://www.walter-tools.com/woc/DSBN">www.walter-tools.com/woc/DSBN</a>	<a href="http://www.walter-tools.com/woc/DSKN">www.walter-tools.com/woc/DSKN</a>	<a href="http://www.walter-tools.com/woc/DSRN">www.walter-tools.com/woc/DSRN</a>	<a href="http://www.walter-tools.com/woc/DSBN-P">www.walter-tools.com/woc/DSBN-P</a>

Type				
Machining				
Designation	PSBN	PSKN	DSDN	DSSN
Approach angle	75°	75°	45°	45°
Clamping system	Lever-type	Lever-type	Claw	Claw
Coolant supply	External	External	External	External
Shank size h [mm]	20–50	20–32	20–32	20–32
Shank size h [Inch]			0,625–1,500	1,000
Insert size l [mm]	12–25	12–19	9–25	12–19
Page in catalogue	A 132	A 134	A 139	A 135
QR code				
	<a href="http://www.walter-tools.com/woc/PSBN">www.walter-tools.com/woc/PSBN</a>	<a href="http://www.walter-tools.com/woc/PSKN">www.walter-tools.com/woc/PSKN</a>	<a href="http://www.walter-tools.com/woc/DSDN">www.walter-tools.com/woc/DSDN</a>	<a href="http://www.walter-tools.com/woc/DSSN">www.walter-tools.com/woc/DSSN</a>

## Square-shank turning toolholders – Negative basic shape

Type				
Machining				
Designation	DSSN...-P	PSDN	PSSN	DTJN
Approach angle	45°	45°	45°	93°
Clamping system	Claw	Lever-type	Lever-type	Claw
Coolant supply	Precision cooling	External	External	External
Shank size h [mm]	25	12–40	16–32	
Shank size h [Inch]				0,750–1,250
Insert size l [mm]	12	9–25	9–19	16–27
Page in catalogue	A 135	A 141	A 138	A 146
QR code				
	<a href="http://www.walter-tools.com/woc/">www.walter-tools.com/woc/</a>	DSSN-P	PSDN	PSSN
				DTJN

Type				
Machining				
Designation	MTJN	DTFN	DTGN	DTGN...-P
Approach angle	93°	91°	91°	91°
Clamping system	Claw	Claw	Claw	Claw
Coolant supply	External	External	External	Precision cooling
Shank size h [mm]	20–32		20–32	20–25
Shank size h [Inch]		1,000		
Insert size l [mm]	16–22	22	16–22	16
Page in catalogue	A 142	A 143	A 144	A 144
QR code				
	<a href="http://www.walter-tools.com/woc/">www.walter-tools.com/woc/</a>	MTJN	DTFN	DTGN
				DTGN-P

## Square-shank turning toolholders – Negative basic shape

Type				
Machining				
Designation	PTFN	PTGN	DVPN	DVTN
Approach angle	91°	91°	117,5°	117,5°
Clamping system	Lever-type	Lever-type	Claw	Claw
Coolant supply	External	External	External	External
Shank size h [mm]	16–25	16–40	25–32	
Shank size h [Inch]				0,750–1,250
Insert size l [mm]	16	11–27	16	16
Page in catalogue	A 148	A 147	A 149	A 156
QR code				
<a href="http://www.walter-tools.com/woc/">www.walter-tools.com/woc/</a>	PTFN	PTGN	DVPN	DVTN

Type				
Machining				
Designation	DVJN	DVJN...-P	DVVN	DWLN
Approach angle	93°	93°	72,5°	95°
Clamping system	Claw	Claw	Claw	Claw
Coolant supply	External	Precision cooling	External	External
Shank size h [mm]	20–32	20–25	20–32	16–32
Shank size h [Inch]	0,750–1,250	0,750–1,000	0,750–1,250	0,750–1,250
Insert size l [mm]	16	16	16	6–10
Page in catalogue	A 150	A 150	A 154	A 157
QR code				
<a href="http://www.walter-tools.com/woc/">www.walter-tools.com/woc/</a>	DVJN	DVJN-P	DVVN	DWLN

## Square-shank turning toolholders – Negative basic shape

Type		
Machining		



Designation	DWLN...-P	PWLN	
Approach angle	95°	95°	
Clamping system	Claw	Lever-type	
Coolant supply	Precision cooling	External	
Shank size h [mm]	20–25	16–32	
Shank size h [Inch]	0,750–1,000		
Insert size l [mm]	8	6–10	
Page in catalogue	A 157	A 161	

QR code		
<a href="http://www.walter-tools.com/woc/">www.walter-tools.com/woc/</a>	DWLN-P	PWLN

## Square-shank turning toolholders – Positive basic shape

Type				
Machining				
Designation	SCLC	SCLC...-P	SCLC...-S-P	SDHC
Approach angle	95°	95°	95°	107,5°
Clamping system	Screw	Screw	Screw	Screw
Coolant supply	External	Precision cooling	Precision cooling	External
Shank size h [mm]	10–25	20–25	10–16	12–25
Shank size h [Inch]	0,375–1,250	0,750–1,000		
Insert size l [mm]	6–12	9	6–9	7–11
Page in catalogue	A 162	A 162	A 162	A 167
QR code				
	<a href="http://www.walter-tools.com/woc/SCLC">www.walter-tools.com/woc/SCLC</a>	<a href="http://www.walter-tools.com/woc/SCLC-P">www.walter-tools.com/woc/SCLC-P</a>	<a href="http://www.walter-tools.com/woc/SCLC-S-P">www.walter-tools.com/woc/SCLC-S-P</a>	<a href="http://www.walter-tools.com/woc/SDHC">www.walter-tools.com/woc/SDHC</a>

Type				
Machining				
Designation	SDJC	SDJC...-P	SDJC...-S-P	DDJC...-P
Approach angle	93°	93°	93°	93°
Clamping system	Screw	Screw	Screw	Claw
Coolant supply	External	Precision cooling	Precision cooling	Precision cooling
Shank size h [mm]	10–25	20–25	10–16	20–25
Shank size h [Inch]	0,375–1,000	0,750–1,000		
Insert size l [mm]	7–11	11	7–11	11
Page in catalogue	A 168	A 168	A 168	A 173
QR code				
	<a href="http://www.walter-tools.com/woc/SDJC">www.walter-tools.com/woc/SDJC</a>	<a href="http://www.walter-tools.com/woc/SVJC-P">www.walter-tools.com/woc/SVJC-P</a>	<a href="http://www.walter-tools.com/woc/SVJC-S-P">www.walter-tools.com/woc/SVJC-S-P</a>	<a href="http://www.walter-tools.com/woc/DDJC-P">www.walter-tools.com/woc/DDJC-P</a>

## Square-shank turning toolholders – Positive basic shape

Type		
Machining		



Designation	SDNC	SDNC...-P	SRAC	SRDC
Approach angle	62,5°	62,5°	0°	0°
Clamping system	Screw	Screw	Screw	Screw
Coolant supply	External	Precision cooling	External	External
Shank size h [mm]	10–25	12–16		12–32
Shank size h [Inch]			1,000–1,250	0,500–1,250
Insert size l [mm]	7–11	7–11	6–12	6–16
Page in catalogue	A 174	A 175	A 176	A 177

QR code				
	<a href="http://www.walter-tools.com/woc/">www.walter-tools.com/woc/</a> SDNC	<a href="http://www.walter-tools.com/woc/">www.walter-tools.com/woc/</a> SDNC-P	<a href="http://www.walter-tools.com/woc/">www.walter-tools.com/woc/</a> SRAC	<a href="http://www.walter-tools.com/woc/">www.walter-tools.com/woc/</a> SRDC

Type			
Machining			



Designation	SRGC	SRSC	PRDC	PRGC
Approach angle	0°	0°	0°	0°
Clamping system	Screw	Screw	Lever-type	Lever-type
Coolant supply	External	External	External	External
Shank size h [mm]		20–32	20–50	20–40
Shank size h [Inch]	1,000	1,000		
Insert size l [mm]	12	6–16	10–32	10–25
Page in catalogue	A 182	A 180	A 179	A 183

QR code				
	<a href="http://www.walter-tools.com/woc/">www.walter-tools.com/woc/</a> SRGC	<a href="http://www.walter-tools.com/woc/">www.walter-tools.com/woc/</a> SRSC	<a href="http://www.walter-tools.com/woc/">www.walter-tools.com/woc/</a> PRDC	<a href="http://www.walter-tools.com/woc/">www.walter-tools.com/woc/</a> PRGC

## Square-shank turning toolholders – Positive basic shape

Type				
Machining				
Designation	SSDC	SSDCN	STGC	SVHB
Approach angle	45°	45°	91°	107,5°
Clamping system	Screw	Screw	Screw	Screw
Coolant supply	External	External	External	External
Shank size h [mm]	16–25	12–25	12–25	16–32
Shank size h [Inch]		0,375–0,750	0,375–1,000	
Insert size l [mm]	9–12	6–12	11–16	11–16
Page in catalogue	A 184	A 184	A 187	A 189
QR code				
<a href="http://www.walter-tools.com/woc/">www.walter-tools.com/woc/</a>	SSDC	SSDCN	STGC	SVHB

Type				
Machining				
Designation	PVHB	SVJB	SVJB...-P	SVJB...-S-P
Approach angle	107,5°	93°	93°	93°
Clamping system	Lever-type	Screw	Screw	Screw
Coolant supply	External	External	Precision cooling	Precision cooling
Shank size h [mm]	16–32	12–32	20–25	10–16
Shank size h [Inch]		0,500–1,000		
Insert size l [mm]	11–16	11–16	16	11
Page in catalogue	A 190	A 191	A 191	A 191
QR code				
<a href="http://www.walter-tools.com/woc/">www.walter-tools.com/woc/</a>	PVHB	SVJB	SVJB-P	SVJB-S-P



## Square-shank turning toolholders – Positive basic shape

Type		
Machining		



Designation	DVJB...-P	PVJB	SVVB	PVVB
Approach angle	93°	93°	72,5°	72,5°
Clamping system	Claw	Lever-type	Screw	Lever-type
Coolant supply	Precision cooling	External	External	External
Shank size h [mm]	20–25	16–32	12–32	20–32
Shank size h [Inch]			0,750–1,000	
Insert size l [mm]	16	11–16	11–16	11–16
Page in catalogue	A 195	A 196	A 197	A 199

QR code				
	<a href="http://www.walter-tools.com/woc/DVJB-P">www.walter-tools.com/woc/DVJB-P</a>	<a href="http://www.walter-tools.com/woc/PVJB">www.walter-tools.com/woc/PVJB</a>	<a href="http://www.walter-tools.com/woc/SVVB">www.walter-tools.com/woc/SVVB</a>	<a href="http://www.walter-tools.com/woc/PVVB">www.walter-tools.com/woc/PVVB</a>

Type	
Machining	



Designation	SWLC
Approach angle	95°
Clamping system	Screw
Coolant supply	External
Shank size h [mm]	12–25
Shank size h [Inch]	
Insert size l [mm]	4–8
Page in catalogue	A 200

QR code	
	<a href="http://www.walter-tools.com/woc/SWLC">www.walter-tools.com/woc/SWLC</a>

## Shank tool – WL Copy turning system

Type



Machining

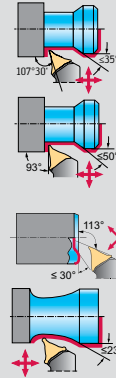

Designation	W1011	W1011...-P	W1011...-S-P
Approach angle	107,5°	107,5°	107,5°
Clamping system	Screw	Screw	Screw
Coolant supply	External	Precision cooling	Precision cooling
Shank size h [mm]	16–25	16–32	12–16
Shank size h [Inch]		0,750–1,000	
Insert size l [mm]	25	17–25	17
Page in catalogue	A 202	A 202	A 205

QR code

[www.walter-tools.com/woc/](http://www.walter-tools.com/woc/)

W1011

W1011-P

W1011-S-P

## Shank tool – WL Copy turning system

Type



Machining

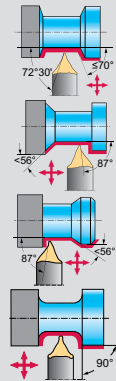

Designation	W1010...-P
Approach angle	72,5°
Clamping system	Screw
Coolant supply	Precision cooling
Shank size h [mm]	16–25
Shank size h [Inch]	0,750–1,000
Insert size l [mm]	17–25
Page in catalogue	A 206

QR code

[www.walter-tools.com/woc/](http://www.walter-tools.com/woc/)

W1010-P

## Square-shank turning toolholders – Ceramic indexable inserts

Type	 RC../RP..	 RN..		
Machining				
				
Designation	CRDC	CRDN	CRSN	CRSN...-P
Approach angle	0°	0°	0°	0°
Clamping system	Claw	Claw	Claw	Claw
Coolant supply	External	External	External	Precision cooling
Shank size h [mm]	32	25–32	25–32	25
Shank size h [Inch]				
Insert size l [mm]	9–12	12	12–15	12
Page in catalogue	A 211	A 210	A 208	A 208
QR code				
<a href="http://www.walter-tools.com/woc/">www.walter-tools.com/woc/</a>	CRDC	CRDN	CRSN	CRSN-P

## Walter Capto™ turning toolholders – Negative basic shape

Type		
Machining		



Designation	C...-DCLN	C...-DCLN...-P	C...-PCLN	C...-DDHN...-P
Approach angle	95°	95°	95°	107,5°
Clamping system	Claw	Claw	Lever-type	Claw
Coolant supply	Internal	Precision cooling	Internal	Precision cooling
Walter Capto™ size	C4–C8	C4–C8	C3–C8	C6

Insert size l [mm]	12–19	12–16	12–25	15
Page in catalogue	A 212	A 212	A 215	A 216

QR code				
<a href="http://www.walter-tools.com/woc/">www.walter-tools.com/woc/</a>	C-DCLN	C-DCLN-P	C-PCLN	C-DDHN-P

Type				
Machining				



Designation	C...-DDJN	C...-DDUN	C...-DDJN...-P	C...-DDUN...-P
Approach angle	93°	93°	93°	93°
Clamping system	Claw	Claw	Claw	Claw
Coolant supply	Internal	Internal	Precision cooling	Precision cooling
Walter Capto™ size	C4–C8	C4–C8	C4–C8	C6

Insert size l [mm]	11–15	15	11–15	15
Page in catalogue	A 217	A 220	A 217	A 220

QR code				
<a href="http://www.walter-tools.com/woc/">www.walter-tools.com/woc/</a>	C-DDJN	C-DDUN	C-DDJN-P	C-DDUN-P

## Walter Capto™ turning toolholders – Negative basic shape

Type				
Machining				
Designation	C...-PDJN	C...-DSKN	C...-DSRN	C...-PSKN
Approach angle	93°	75°	75°	75°
Clamping system	Lever-type	Claw	Claw	Lever-type
Coolant supply	Internal	Internal	Internal	Internal
Walter Capto™ size	C3–C6	C4–C8	C4–C8	C6–C8
Insert size l [mm]	11–15	12–19	12–25	15–19
Page in catalogue	A 219	A 225	A 222	A 226
QR code				
<a href="http://www.walter-tools.com/woc/">www.walter-tools.com/woc/</a>	C-PDJN	C-DSKN	C-DSRN	C-PSKN

Type				
Machining				
Designation	C...-PSRN	C...-DSDN	C...-DSSN	C...-MTJN
Approach angle	75°	45°	45°	93°
Clamping system	Lever-type	Claw	Claw	Claw
Coolant supply	Internal	Internal	Internal	Internal
Walter Capto™ size	C6–C8	C4–C8	C4–C6	C4–C6
Insert size l [mm]	19–25	12–25	12–19	16–22
Page in catalogue	A 224	A 228	A 227	A 229
QR code				
<a href="http://www.walter-tools.com/woc/">www.walter-tools.com/woc/</a>	C-PSRN	C-DSDN	C-DSSN	C-MTJN

## Walter Capto™ turning toolholders – Negative basic shape

Type			
Machining			



Designation	C...-DTGN...-P	C...-DVJN	C...-DVJN...-P	C...-DWLN
Approach angle	91°	93°	93°	95°
Clamping system	Claw	Claw	Claw	Claw
Coolant supply	Precision cooling	Internal	Precision cooling	Internal
Walter Capto™ size	C4	C4–C8	C4–C6	C4–C6

Insert size l [mm]	16	16	16	6–10
Page in catalogue	A 230	A 231	A 231	A 233

QR code				
	<a href="http://www.walter-tools.com/woc/C-DTGN-P">www.walter-tools.com/woc/C-DTGN-P</a>	<a href="http://www.walter-tools.com/woc/C-DVJN">www.walter-tools.com/woc/C-DVJN</a>	<a href="http://www.walter-tools.com/woc/C-DVJN-P">www.walter-tools.com/woc/C-DVJN-P</a>	<a href="http://www.walter-tools.com/woc/C-DWLN">www.walter-tools.com/woc/C-DWLN</a>

Type	
Machining	



Designation	C...-DWLN...-P	C...-PWLN
Approach angle	95°	95°
Clamping system	Claw	Lever-type
Coolant supply	Precision cooling	Internal
Walter Capto™ size	C4–C6	C3–C6

Insert size l [mm]	8	6–10
Page in catalogue	A 233	A 235

QR code		
	<a href="http://www.walter-tools.com/woc/C-DWLN-P">www.walter-tools.com/woc/C-DWLN-P</a>	<a href="http://www.walter-tools.com/woc/C-PWLN">www.walter-tools.com/woc/C-PWLN</a>

## Walter Capto™ turning toolholders – Positive basic shape

Type				
Machining				
Designation	C...-SCLC	C...-SDJC	C...-DDJC...-P	C...-SDNC
Approach angle	95°	93°	93°	62,5°
Clamping system	Screw	Screw	Claw	Screw
Coolant supply	Internal	Internal	Precision cooling	Internal
Walter Capto™ size	C3–C6	C3–C6	C4–C5	C3–C5
Insert size l [mm]	9–12	7–11	11	11
Page in catalogue	A 236	A 238	A 237	A 239
QR code				
<a href="http://www.walter-tools.com/woc/">www.walter-tools.com/woc/</a>	C-SCLC	C-SDJC	C-DDJC-P	C-SDNC

Type					
Machining					
Designation	C...-SRDC	C...-SRSC	C...-PRSC	C...-STGC	
Approach angle	0°	0°	0°	91°	
Clamping system	Screw	Screw	Lever-type	Screw	
Coolant supply	Internal	Internal	Internal	Internal	
Walter Capto™ size	C3–C6	C4–C6	C5–C8	C4–C5	
Insert size l [mm]	6–16	6–16	16–25	11–16	
Page in catalogue	A 240	A 241	A 242	A 243	
QR code					
<a href="http://www.walter-tools.com/woc/">www.walter-tools.com/woc/</a>	C-SRDC	C-SRSC	C-PRSC	C-STGC	



## Walter Capto™ turning toolholders – Positive basic shape

Type			
Machining			



Designation	C...-SVHB	C...-SVJB	C...-DVJB...-P	C...-SVVB
Approach angle	107,5°	93°	93°	72,5°
Clamping system	Screw	Screw	Claw	Screw
Coolant supply	Internal	Internal	Precision cooling	Internal
Walter Capto™ size	C3–C6	C3–C6	C4–C8	C4–C6

Insert size l [mm]	11–16	11–16	16	11–16
Page in catalogue	A 244	A 245	A 246	A 247

QR code				
www.walter-tools.com/woc/	C-SVHB	C-SVJB	C-DVJB-P	C-SVVB



## Walter Capto™ – WL copy turn system

Type

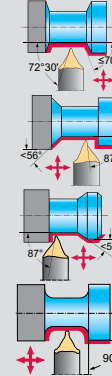
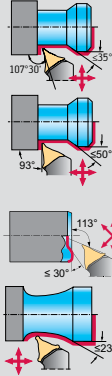

Machining



Designation	W1011-C...-P	W1010-C...-P	
Approach angle	107,5°	72,5°	
Clamping system	Screw	Screw	
Coolant supply	Precision cooling	Precision cooling	
Walter Capto™ size	C4-C6	C4-C6	
Insert size l [mm]	25	25	
Page in catalogue	A 248	A 249	
QR code			
	<a href="http://www.walter-tools.com/woc/W1011-C-P">www.walter-tools.com/woc/W1011-C-P</a>	<a href="http://www.walter-tools.com/woc/W1010-C-P">www.walter-tools.com/woc/W1010-C-P</a>	

## Square-shank turning toolholders – Ceramic indexable inserts

Type	 RN..	
Machining		



Designation	C...-CRSN...-P	
Approach angle	0°	
Clamping system	Claw	
Coolant supply	Precision cooling	
Walter Capto™ size	C6	
Insert size l [mm]	12	
Page in catalogue	A 251	

QR code

[www.walter-tools.com/woc/](http://www.walter-tools.com/woc/)

C-CRSN-P

## Walter Capto™ turning toolholders – Turning and milling centers

Type				
Machining				
Designation	C...-SCMC	C...-DCMN	C...-DDMN	C...-SRDC
Approach angle	95°	95°	93°	0°
Clamping system	Screw	Claw	Claw	Screw
Coolant supply	axial	axial	axial	Internal
Walter Capto™ size	C6	C5–C8	C5–C8	C6
Insert size l [mm]	12	12–16	15	10–16
Page in catalogue	A 255	A 252	A 253	A 240
QR code				
	<a href="http://www.walter-tools.com/woc/C-SCMC">www.walter-tools.com/woc/C-SCMC</a>	<a href="http://www.walter-tools.com/woc/C-DCMN">www.walter-tools.com/woc/C-DCMN</a>	<a href="http://www.walter-tools.com/woc/C-DDMN">www.walter-tools.com/woc/C-DDMN</a>	<a href="http://www.walter-tools.com/woc/C-SRDC">www.walter-tools.com/woc/C-SRDC</a>

Type		
Machining		
Designation	C...-SVMB	C...-DVMN
Approach angle	95°	95°
Clamping system	Screw	Claw
Coolant supply	axial	axial
Walter Capto™ size	C5–C6	C8
Insert size l [mm]	16	16
Page in catalogue	A 257	A 254
QR code		
	<a href="http://www.walter-tools.com/woc/C-SVMB">www.walter-tools.com/woc/C-SVMB</a>	<a href="http://www.walter-tools.com/woc/C-DVMN">www.walter-tools.com/woc/C-DVMN</a>

## Shank tool – Rigid clamping

DCLN 

Walter Turn

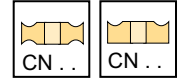
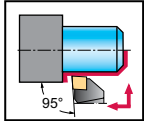

## Tool

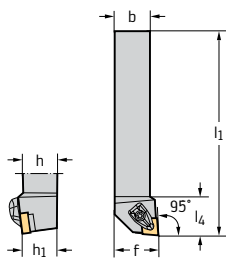

Square shank

Designation		h = h <sub>1</sub> mm	b mm	l <sub>1</sub> mm	l <sub>4</sub> mm	f mm	γ	λ <sub>s</sub>	Type
DCLNR1616H12		12	16	100	32,2	20	-6°	-6°	CN .. 1204 ..
DCLNR2020K12		12	20	125	32	25	-6°	-6°	
DCLNR2525M12		12	25	150	32	32	-6°	-6°	
DCLNR3225P12		12	32	170	32	32	-6°	-6°	
DCLNR2525M16		16	25	150	39	32	-6°	-6°	CN .. 1606 ..
DCLNR3225P16		16	32	170	39	32	-6°	-6°	
DCLNR3232P16		16	32	170	39	40	-6°	-6°	
DCLNR3232P19		19	32	170	43,2	40	-6°	-6°	CN .. 1906 ..
DCLNL1616H12		12	16	100	32,2	20	-6°	-6°	CN .. 1204 ..
DCLNL2020K12		12	20	125	32	25	-6°	-6°	
DCLNL2525M12		12	25	150	32	32	-6°	-6°	
DCLNL3225P12		12	32	170	32	32	-6°	-6°	
DCLNL2525M16		16	25	150	39	32	-6°	-6°	CN .. 1606 ..
DCLNL3225P16		16	32	170	39	32	-6°	-6°	
DCLNL3232P16		16	32	170	39	40	-6°	-6°	
DCLNL3232P19		19	32	170	43,2	40	-6°	-6°	CN .. 1906 ..

Dimensional drawing shows right-hand version. | Measured with master insert: CN .. 120408 / CN .. 160612 / CN .. 190612 | Refer to the Walter online catalogue for more product information: [www.walter-tools.com](http://www.walter-tools.com) | Bodies and assembly parts are included in the scope of delivery

## Assembly parts

Type h = h <sub>1</sub> (mm)	CN .. 1204 .. 16	CN .. 1204 .. 20–32	CN .. 1606 .. 25–32	CN .. 1906 .. 32
Shim	AP354-CN12	AP301-CN12	AP302-CN16	AP303-CN19
Screw for shim Tightening torque	FS1461 (T15IP) 2,5 Nm	FS1461 (T15IP) 2,5 Nm	FS1463 (T20IP) 5 Nm	FS1463 (T20IP) 5 Nm
Clamp	PK241	PK241	PK242	PK243
Screw for clamp Tightening torque	FS1473 (T15IP) 3,9 Nm	FS1473 (T15IP) 3,9 Nm	FS1474 (T20IP) 6,4 Nm	FS1474 (T20IP) 6,4 Nm
Pressure spring	FS1470	FS1470	FS1471	FS1471
Pin	RS117	RS117	RS117	RS117
Torx key	FS1465 (T15IP)	FS1465 (T15IP)		
Allen key			FS1464 (T20IP)	FS1464 (T20IP)

## Accessories

Type	CN .. 1204 ..	CN .. 1606 ..	CN .. 1906 ..
(standard assembly parts) Clamp set	PK241-SET	PK242-SET	PK243-SET
Insert with hole Carbide clamp set	PK245-SET	PK246-SET	
Insert with hole Carbide clamp set	PK254-SET		
Shim for CN .. 1207 ..	AP411-CN1207		

## Shank tool – Rigid clamping

DCLN inch

Walter Turn

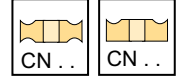
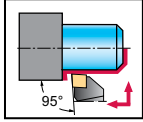

## Tool

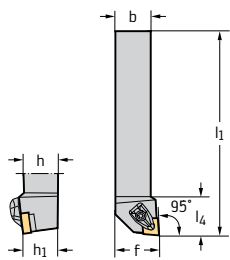





Square shank

Designation		h = h <sub>1</sub> inch	b inch	l <sub>1</sub> inch	l <sub>4</sub> inch	f inch	γ	λ <sub>s</sub>	Type
DCLNR103A		9	0,625	0,625	4,000	0,978	-6°	-6°	CN .. 0903 .. CN .. 32 ..
DCLNR123C		9	0,750	0,750	5,000	0,978	-6°	-6°	
DCLNR104A		12	0,625	0,625	4,000	1,260	-6°	-6°	CN .. 1204 .. CN .. 43 ..
DCLNR124B		12	0,750	0,750	4,500	1,000	-6°	-6°	
DCLNR164C		12	1,000	1,000	5,000	1,250	-6°	-6°	
DCLNR164D		12	1,000	1,000	6,000	1,250	-6°	-6°	
DCLNR204D		12	1,250	1,250	6,000	1,500	-6°	-6°	
DCLNR244D		12	1,500	1,500	6,000	2,000	-6°	-6°	
DCLNR165D		16	1,000	1,000	6,000	1,540	-6°	-6°	CN .. 1606 .. CN .. 54 ..
DCLNR205D		16	1,250	1,250	6,000	1,540	-6°	-6°	
DCLNR245D		16	1,500	1,500	6,000	2,000	-6°	-6°	
DCLNR206D		19	1,250	1,250	6,000	1,700	-6°	-6°	CN .. 1906 .. CN .. 64 ..
DCLNR246D		19	1,500	1,500	6,000	1,700	-6°	-6°	
DCLNL103A		9	0,625	0,625	4,000	0,978	-6°	-6°	CN .. 0903 .. CN .. 32 ..
DCLNL123C		9	0,750	0,750	5,000	0,978	-6°	-6°	
DCLNL104A		12	0,625	0,625	4,000	1,260	-6°	-6°	CN .. 1204 .. CN .. 43 ..
DCLNL124B		12	0,750	0,750	4,500	1,000	-6°	-6°	
DCLNL164C		12	1,000	1,000	5,000	1,250	-6°	-6°	
DCLNL164D		12	1,000	1,000	6,000	1,250	-6°	-6°	
DCLNL204D		12	1,250	1,250	6,000	1,500	-6°	-6°	
DCLNL244D		12	1,500	1,500	6,000	2,000	-6°	-6°	
DCLNL165D		16	1,000	1,000	6,000	1,540	-6°	-6°	CN .. 1606 .. CN .. 54 ..
DCLNL205D		16	1,250	1,250	6,000	1,540	-6°	-6°	
DCLNL245D		16	1,500	1,500	6,000	2,000	-6°	-6°	
DCLNL206D		19	1,250	1,250	6,000	1,700	-6°	-6°	CN .. 1906 .. CN .. 64 ..
DCLNL246D		19	1,500	1,500	6,000	1,700	-6°	-6°	

Dimensional drawing shows right-hand version. | Measured with master insert: CN .. 090308 / CN .. 120408 / CN .. 160612 / CN .. 190612 | Refer to the Walter online catalogue for more product information: [www.walter-tools.com](http://www.walter-tools.com) | Bodies and assembly parts are included in the scope of delivery

## Assembly parts

Type	h = h <sub>1</sub> [inch]	CN .. 0903 .. 0,625–0,75	CN .. 1204 .. 0,625	CN .. 1204 .. 0,75–1,5	CN .. 1606 .. 1–1,5	CN .. 1906 .. 1,25–1,5
	Shim	AP414-CN09	AP354-CN12	AP301-CN12	AP302-CN16	AP303-CN19
	Screw for shim Tightening torque	FS1462 (T9IP) 1,106 lbs	FS1461 (T15IP) 1,844 lbs	FS1461 (T15IP) 1,844 lbs	FS1463 (T20IP) 3,688 lbs	FS1463 (T20IP) 3,688 lbs
	Clamp	PK240	PK241	PK241	PK242	PK243
	Screw for clamp Tightening torque	FS1472 (T9IP) 1,254 lbs	FS1473 (T15IP) 2,876 lbs	FS1473 (T15IP) 2,876 lbs	FS1474 (T20IP) 4,72 lbs	FS1474 (T20IP) 4,72 lbs
	Pressure spring	FS1469	FS1470	FS1470	FS1471	FS1471
	Pin	RS116	RS117	RS117	RS117	RS117
	Torx key	FS1466 (T9IP)	FS1465 (T15IP)	FS1465 (T15IP)		
	Allen key				FS1464 (T20IP)	FS1464 (T20IP)

Accessories					
	Type	CN .. 0903 ..	CN .. 1204 ..	CN .. 1606 ..	CN .. 1906 ..
	(standard assembly parts) Clamp set	PK240-SET	PK241-SET	PK242-SET	PK243-SET
	Insert with hole Carbide clamp set		PK245-SET	PK246-SET	
	Insert with hole Carbide clamp set		PK254-SET		
	CN..1207.. Shim for CN .. 1207 ..		AP411-CN1207		

## Shank tool – Rigid clamping

DCLN...-P 

## Walter Turn

– Precision cooling

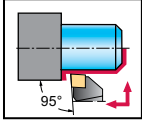

## Tool

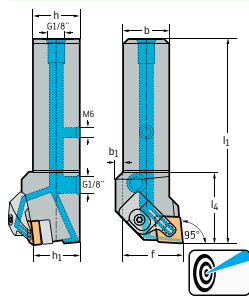

Designation		h = h <sub>1</sub> mm	b mm	b <sub>1</sub> mm	l <sub>1</sub> mm	l <sub>4</sub> mm	f mm	γ	λ <sub>s</sub>	Type	
DCLNR2020X12-P		12	20	20	10	115	38,5	25	-6°	-6°	CN .. 1204 ..
DCLNR2525X12-P		12	25	25	4	130	38,5	32	-6°	-6°	
DCLNR2525X16-P		16	25	25	12	135	43,5	32	-6°	-6°	CN .. 1606 ..
DCLNR3232X16-P		16	32	32	6	147	43,5	40	-5,5°	-6°	
DCLNL2020X12-P		12	20	20	10	115	38,5	25	-6°	-6°	CN .. 1204 ..
DCLNL2525X12-P		12	25	25	4	130	38,5	32	-6°	-6°	
DCLNL2525X16-P		16	25	25	12	135	43,5	32	-6°	-6°	CN .. 1606 ..
DCLNL3232X16-P		16	32	32	6	147	43,5	40	-5,5°	-6°	

Square shank

Dimensional drawing shows right-hand version. | Measured with master insert: CN .. 120408 / CN .. 160612 | For the connection set for internal coolant supply with G1/8" thread, see „Assembly parts and accessories“ | The maximum recommended coolant pressure is 150 bar (2175 psi) | Refer to the Walter online catalogue for more product information: [www.walter-tools.com](http://www.walter-tools.com) | Bodies and assembly parts are included in the scope of delivery

## Assembly parts

	Type h = h <sub>1</sub> [mm]	CN .. 1204 .. 20–25	CN .. 1606 .. 25–32
	Shim	AP301-CN12	AP302-CN16
	Screw for shim Tightening torque	FS1461 (T15IP) 2,5 Nm	FS1463 (T20IP) 5 Nm
	Clamp		PK267
	Left clamp	PK265L	
	Right clamp	PK265R	
	Screw for clamp Tightening torque	FS1473 (T15IP) 3,9 Nm	FS1474 (T20IP) 6,4 Nm
	Pressure spring	FS2188	FS2298
	G 1/8" threaded plug	FS2258 (SW 2)	FS2258 (SW 2)
	M6 threaded plug	FS2288 (SW 3)	FS2288 (SW 3)
	Torx key	FS1465 (T15IP)	
	Allen key		FS1464 (T20IP)

## Accessories

	Type	CN .. 1204 ..	CN .. 1606 ..
	(standard assembly parts) Clamp set		PK267-SET
	(standard assembly parts) Left clamp set	PK265L-SET	
	(standard assembly parts) Right clamp set	PK265R-SET	



# Shank tool – Rigid clamping

DCLN...-P inch

**Walter Turn**



– Precision cooling

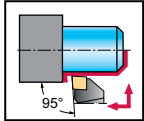

Tool	Designation		h = h <sub>1</sub> inch	b inch	b <sub>1</sub> inch	l <sub>1</sub> inch	l <sub>4</sub> inch	f inch	γ	λ <sub>s</sub>	Type
	DCLNR124B-P	12	0,750	0,750	0,394	4,500	1,575	1,000	-6°	-6°	CN .. 1204 .. CN .. 43 ..
	DCLNR164D-P	12	1,000	1,000	0,157	6,000	1,516	1,250	-6°	-6°	
	DCLNR165D-P	16	1,000	1,000	0,472	6,000	1,713	1,250	-6°	-6°	CN .. 1606 .. CN .. 54 ..
	DCLNL124B-P	12	0,750	0,750	0,394	4,500	1,575	1,000	-6°	-6°	CN .. 1204 .. CN .. 43 ..
	DCLNL164D-P	12	1,000	1,000	0,157	6,000	1,516	1,250	-6°	-6°	
	DCLNL165D-P	16	1,000	1,000	0,472	6,000	1,713	1,250	-6°	-6°	CN .. 1606 .. CN .. 54 ..

Square shank

Dimensional drawing shows right-hand version. | Measured with master insert: CN .. 120408 / CN .. 160612 | For the connection set for internal coolant supply with G1/8" thread, see „Assembly parts and accessories“ | The maximum recommended coolant pressure is 150 bar (2175 psi) | Refer to the Walter online catalogue for more product information: [www.walter-tools.com](http://www.walter-tools.com) | Bodies and assembly parts are included in the scope of delivery

Assembly parts		CN .. 1204 .. 0,75-1	CN .. 1606 .. 1
	Shim	AP301-CN12	AP302-CN16
	Screw for shim Tightening torque	FS1461 (T15IP) 1,844 lbs	FS1463 (T20IP) 3,688 lbs
	Clamp		PK267
	Left clamp	PK265L	
	Right clamp	PK265R	
	Screw for clamp Tightening torque	FS1473 (T15IP) 2,876 lbs	FS1474 (T20IP) 4,72 lbs
	Pressure spring	FS2188	FS2298
	G 1/8" threaded plug	FS2258 (SW 2)	FS2258 (SW 2)
	M6 threaded plug	FS2288 (SW 3)	FS2288 (SW 3)
	Torx key	FS1465 (T15IP)	
	Allen key		FS1464 (T20IP)

Accessories		CN .. 1204 ..	CN .. 1606 ..
	(standard assembly parts) Clamp set		PK267-SET
	(standard assembly parts) Left clamp set	PK265L-SET	
	(standard assembly parts) Right clamp set	PK265R-SET	

## Shank tool – Lever clamping

PCLN 

Walter Turn

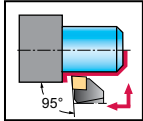



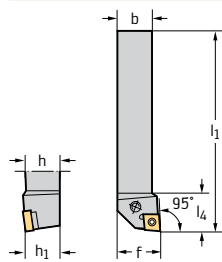



## Tool



Square shank

Designation		h = h <sub>1</sub> mm	b mm	f mm	l <sub>4</sub> mm	l <sub>1</sub> mm	γ	λ <sub>s</sub>	Type
PCLNR1616H09		9	16	20	24,2	100	-6°	-6°	CN .. 0903 ..
PCLNR2020K09		9	20	25	24,2	125	-6°	-6°	
PCLNR2525M09		9	25	32	24,2	150	-6°	-6°	
PCLNR1616H12		12	16	20	27,2	100	-6°	-6°	CN .. 1204 ..
PCLNR2020K12		12	20	25	27,2	125	-6°	-6°	
PCLNR2525M12		12	25	32	27,2	150	-6°	-6°	
PCLNR3225P12		12	32	32	27,2	170	-6°	-6°	
PCLNR2525M16		16	25	32	33,9	150	-6°	-6°	CN .. 1606 ..
PCLNR3225P16		16	32	32	33,9	170	-6°	-6°	
PCLNR3232P16		16	32	40	33,9	170	-6°	-6°	
PCLNR3232P19		19	32	40	37,9	170	-6°	-6°	CN .. 1906 ..
PCLNR4040S19		19	40	50	37,9	250	-6°	-6°	
PCLNR4040S25		25	40	50	50	250	-6°	-6°	CN .. 2509 ..
PCLNR5050T25		25	50	60	50	300	-6°	-6°	
PCLNL1616H09		9	16	20	24,2	100	-6°	-6°	CN .. 0903 ..
PCLNL2020K09		9	20	25	24,2	125	-6°	-6°	
PCLNL2525M09		9	25	32	24,2	150	-6°	-6°	
PCLNL1616H12		12	16	20	27,2	100	-6°	-6°	CN .. 1204 ..
PCLNL2020K12		12	20	25	27,2	125	-6°	-6°	
PCLNL2525M12		12	25	32	27,2	150	-6°	-6°	
PCLNL3225P12		12	32	32	27,2	170	-6°	-6°	
PCLNL2525M16		16	25	32	33,9	150	-6°	-6°	CN .. 1606 ..
PCLNL3225P16		16	32	32	33,9	170	-6°	-6°	
PCLNL3232P16		16	32	40	33,9	170	-6°	-6°	
PCLNL3232P19		19	32	40	37,9	170	-6°	-6°	CN .. 1906 ..
PCLNL4040S19		19	40	50	37,9	250	-6°	-6°	
PCLNL4040S25		25	40	50	50	250	-6°	-6°	CN .. 2509 ..
PCLNL5050T25		25	50	60	50	300	-6°	-6°	

Dimensional drawing shows right-hand version. | Measured with master insert: CN .. 090308 / CN .. 120408 / CN .. 160612 / CN .. 190612 / CN .. 250924 | Refer to the Walter online catalogue for more product information: [www.walter-tools.com](http://www.walter-tools.com) | Bodies and assembly parts are included in the scope of delivery

Assembly parts		CN .. 0903 .. 16-25	CN .. 1204 .. 16	CN .. 1204 .. 20-32	CN .. 1606 .. 25-32	CN .. 1906 .. 32-40	CN .. 2509 .. 40-50
Type	h = h <sub>1</sub> [mm]						
	Shim	AP408- CN0908	AP134-CN1216	AP134-CN1216	AP135-CN1624	AP136-CN1924	AP192- CN2524
	Lever	KN101	KN121	KN102	KN104	KN106	KN107
	Clamping screw Tightening torque	FS351 (SW 2,5) 2 Nm	FS2129 (SW 3) 5 Nm	FS352 (SW 3) 5 Nm	FS354 (SW 3) 5 Nm	FS356 (SW 4) 10 Nm	FS357 (SW 5) 14 Nm
	Shim pin	RS120	RS102	RS102	RS103	RS104	RS105
	Tapered assembly pin	MD101	MD101	MD101	MD102	MD102	MD103
	Allen key	ISO2936-2,5 (SW 2,5)	ISO2936-3 (SW 3)	ISO2936-3 (SW 3)	ISO2936-3 (SW 3)	ISO2936-4 (SW 4)	ISO2936-5 (SW 5)

  

Accessories		CN .. 0903 ..-CN .. 2509 ..	CN .. 1204 ..	CN .. 1606 ..	CN .. 1906 ..
Type					
	Shim		AP134-CN1208	AP135-CN1616	AP136-CN1912

## Shank tool – Rigid clamping

DCBN 

Walter Turn

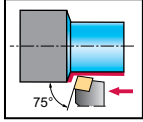

## Tool

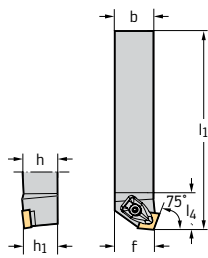

Square shank

Designation		h = h <sub>1</sub> mm	b mm	l <sub>1</sub> mm	l <sub>4</sub> mm	f mm	γ	λ <sub>s</sub>	Type
DCBNR2525M12		12	25	150	34,6	22	-6°	-6°	CN .. 1204 ..
DCBNR3225P12		12	32	170	34,6	22	-6°	-6°	
DCBNR2525M16		16	25	150	41,5	22	-6°	-6°	CN .. 1606 ..
DCBNR3232P16		16	32	170	41,6	27	-6°	-6°	
DCBNR3232P19		19	32	170	46,1	27	-6°	-6°	CN .. 1906 ..
DCBNL2525M12		12	25	150	34,6	22	-6°	-6°	CN .. 1204 ..
DCBNL3225P12		12	32	170	34,6	22	-6°	-6°	
DCBNL2525M16		16	25	150	41,5	22	-6°	-6°	CN .. 1606 ..
DCBNL3232P16		16	32	170	41,6	27	-6°	-6°	
DCBNL3232P19		19	32	170	46,1	27	-6°	-6°	CN .. 1906 ..

Dimensional drawing shows right-hand version. | Measured with master insert: CN .. 120408 / CN .. 160612 / CN .. 190612 | Refer to the Walter online catalogue for more product information: [www.walter-tools.com](http://www.walter-tools.com) | Bodies and assembly parts are included in the scope of delivery

## Assembly parts

Type	Type	CN .. 1204 .. 25–32	CN .. 1606 .. 25–32	CN .. 1906 .. 32
	Shim	AP301-CN12	AP302-CN16	AP303-CN19
	Screw for shim Tightening torque	FS1461 (T15IP) 2,5 Nm	FS1463 (T20IP) 5 Nm	FS1463 (T20IP) 5 Nm
	Clamp	PK241	PK242	PK243
	Screw for clamp Tightening torque	FS1473 (T15IP) 3,9 Nm	FS1474 (T20IP) 6,4 Nm	FS1474 (T20IP) 6,4 Nm
	Pressure spring	FS1470	FS1471	FS1471
	Pin	RS117	RS117	RS117
	Torx key	FS1465 (T15IP)		
	Allen key		FS1464 (T20IP)	FS1464 (T20IP)

## Accessories

Type	Type	CN .. 1204 ..	CN .. 1606 ..	CN .. 1906 ..
	(standard assembly parts) Clamp set	PK241-SET	PK242-SET	PK243-SET
	Insert with hole Carbide clamp set	PK245-SET	PK246-SET	
	Insert with hole Carbide clamp set	PK254-SET		
	Shim for CN .. 1207 ..	AP411-CN1207		

## Shank tool – Rigid clamping

DCRN inch

Walter Turn

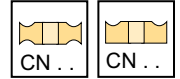
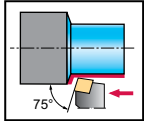

## Tool

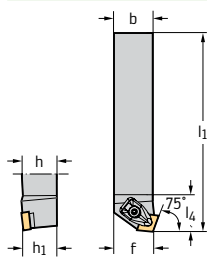







Square shank



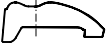

Designation		h = h <sub>1</sub> inch	b inch	l <sub>1</sub> inch	l <sub>4</sub> inch	f inch	γ	λ <sub>s</sub>	Type
DCRNR164DM1	12	1,000	1,000	6,000	1,350	1,048	-6°	-6°	CN .. 1204 .. CN .. 43 ..
DCRNR205D	16	1,250	1,250	6,000	1,640	1,291	-6°	-6°	CN .. 1606 .. CN .. 54 ..
DCRNR206D	19	1,250	1,250	6,000	1,820	1,291	-6°	-6°	CN .. 1906 .. CN .. 64 ..
DCRNL164DM1	12	1,000	1,000	6,000	1,350	1,048	-6°	-6°	CN .. 1204 .. CN .. 43 ..
DCRNL205D	16	1,250	1,250	6,000	1,640	1,291	-6°	-6°	CN .. 1606 .. CN .. 54 ..
DCRNL206D	19	1,250	1,250	6,000	1,820	1,291	-6°	-6°	CN .. 1906 .. CN .. 64 ..

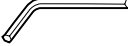
Dimensional drawing shows right-hand version. | Measured with master insert: CN .. 120408 / CN .. 160612 / CN .. 190612 | Refer to the Walter online catalogue for more product information: [www.walter-tools.com](http://www.walter-tools.com) | Bodies and assembly parts are included in the scope of delivery

## Assembly parts

	Type h = h <sub>1</sub> [inch]	CN .. 1204 .. 1	CN .. 1606 .. 1,25	CN .. 1906 .. 1,25
	Shim	AP301-CN12	AP302-CN16	AP303-CN19
	Screw for shim Tightening torque	FS1461 (T15IP) 1,844 lbs	FS1463 (T20IP) 3,688 lbs	FS1463 (T20IP) 3,688 lbs
	Clamp	PK241	PK242	PK243
	Screw for clamp Tightening torque	FS1473 (T15IP) 2,876 lbs	FS1474 (T20IP) 4,72 lbs	FS1474 (T20IP) 4,72 lbs
	Pressure spring	FS1470	FS1471	FS1471
	Pin	RS117	RS117	RS117
	Torx key	FS1465 (T15IP)		
	Allen key		FS1464 (T20IP)	FS1464 (T20IP)

## Accessories

	Type	CN .. 1204 ..	CN .. 1606 ..	CN .. 1906 ..
	(standard assembly parts) Clamp set	PK241-SET	PK242-SET	PK243-SET
	Insert with hole Carbide clamp set	PK245-SET	PK246-SET	
	Insert with hole Carbide clamp set	PK254-SET		
	CN..1207.. Shim for basic shape	AP411-CN1207		

## Shank tool – Lever clamping

PCBN 

Walter Turn

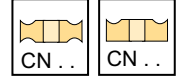
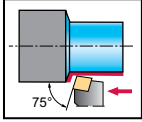

## Tool

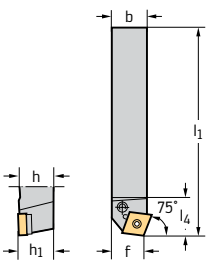

Designation		h = h <sub>1</sub> mm	b mm	f mm	l <sub>4</sub> mm	l <sub>1</sub> mm	γ	λ <sub>s</sub>	Type
PCBNR2525M12		12	25	22	26,9	150	-6°	-6°	CN .. 1204 ..
PCBNR2525M16		16	25	22	33,6	150	-6°	-6°	CN .. 1606 ..
PCBNR3232P16		16	32	27	33,6	170	-6°	-6°	
PCBNR3232P19		19	32	27	37,5	170	-6°	-6°	CN .. 1906 ..
PCBNL2525M12		12	25	22	26,9	150	-6°	-6°	CN .. 1204 ..
PCBNL2525M16		16	25	22	33,6	150	-6°	-6°	CN .. 1606 ..
PCBNL3232P16		16	32	27	33,6	170	-6°	-6°	
PCBNL3232P19		19	32	27	37,5	170	-6°	-6°	CN .. 1906 ..

Square shank

Dimensional drawing shows right-hand version. | Measured with master insert: CN .. 120408 / CN .. 160612 / CN .. 190612 | Refer to the Walter online catalogue for more product information: [www.walter-tools.com](http://www.walter-tools.com) | Bodies and assembly parts are included in the scope of delivery

## Assembly parts

Type h = h <sub>1</sub> [mm]	CN .. 1204 .. 25	CN .. 1606 .. 25–32	CN .. 1906 .. 32
Shim	AP134-CN1216	AP135-CN1624	AP136-CN1924
Lever	KN102	KN104	KN106
Clamping screw Tightening torque	FS352 (SW 3) 5 Nm	FS354 (SW 3) 5 Nm	FS356 (SW 4) 10 Nm
Shim pin	RS102	RS103	RS104
Tapered assembly pin	MD101	MD102	MD102
Allen key	ISO2936-3 (SW 3)	ISO2936-3 (SW 3)	ISO2936-4 (SW 4)

## Accessories

Type	CN .. 1204 ..	CN .. 1606 ..	CN .. 1906 ..
Shim	AP134-CN1208	AP135-CN1616	AP136-CN1912

## Shank tool – Rigid clamping

DCKN 

Walter Turn

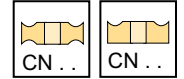
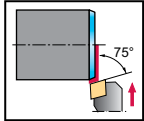

## Tool

Designation		h = h <sub>1</sub> mm	b mm	l <sub>1</sub> mm	l <sub>4</sub> mm	f mm	γ	λ <sub>s</sub>	Type	
									CN ..	
DCKNR2525M12		12	25	150	21,1	32	-6°	-6°	CN .. 1204 ..	
DCKNR3225P12		12	32	170	21,1	32	-6°	-6°	CN .. 1204 ..	
DCKNR3232P16		16	32	170	26	40	-6°	-6°	CN .. 1606 ..	
DCKNL2525M12		12	25	150	21,1	32	-6°	-6°	CN .. 1204 ..	
DCKNL3225P12		12	32	170	21,1	32	-6°	-6°	CN .. 1204 ..	
DCKNL3232P16		16	32	170	26	40	-6°	-6°	CN .. 1606 ..	

Square shank

Dimensional drawing shows right-hand version. | Measured with master insert: CN .. 120408 / CN .. 160612 | Refer to the Walter online catalogue for more product information: [www.walter-tools.com](http://www.walter-tools.com) | Bodies and assembly parts are included in the scope of delivery

## Assembly parts

	Type h = h <sub>1</sub> [mm]	CN .. 1204 .. 25–32	CN .. 1606 .. 32
	Shim	AP301-CN12	AP302-CN16
	Screw for shim Tightening torque	FS1461 (T15IP) 2,5 Nm	FS1463 (T20IP) 5 Nm
	Clamp	PK241	PK242
	Screw for clamp Tightening torque	FS1473 (T15IP) 3,9 Nm	FS1474 (T20IP) 6,4 Nm
	Pressure spring	FS1470	FS1471
	Pin	RS117	RS117
	Torx key	FS1465 (T15IP)	
	Allen key		FS1464 (T20IP)

## Accessories

	Type	CN .. 1204 ..	CN .. 1606 ..
	(standard assembly parts) Clamp set	PK241-SET	PK242-SET
	Insert with hole Carbide clamp set	PK245-SET	PK246-SET
	Insert with hole Carbide clamp set	PK254-SET	
	Shim for CN .. 1207 ..	AP411-CN1207	

## Shank tool – Rigid clamping

DCKN inch

Walter Turn

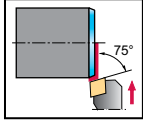

## Tool

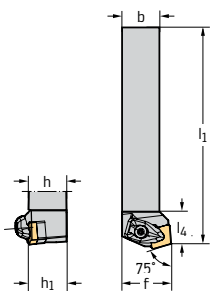

Square shank

Designation		h = h <sub>1</sub> inch	b inch	l <sub>1</sub> inch	l <sub>4</sub> inch	f inch	γ	λ <sub>s</sub>	Type	
DCKNR164D		12	1,000	1,000	6,000	0,837	1,250	-6°	-6°	CN .. 1204 .. CN .. 43 ..
DCKNR205D		16	1,250	1,250	6,000	1,065	1,500	-6°	-6°	CN .. 1606 .. CN .. 54 ..
DCKNL164D		12	1,000	1,000	6,000	0,837	1,250	-6°	-6°	CN .. 1204 .. CN .. 43 ..
DCKNL205D		16	1,250	1,250	6,000	1,065	1,500	-6°	-6°	CN .. 1606 .. CN .. 54 ..

Dimensional drawing shows right-hand version. | Measured with master insert: CN .. 120408 / CN .. 160612 | Refer to the Walter online catalogue for more product information: [www.walter-tools.com](http://www.walter-tools.com) | Bodies and assembly parts are included in the scope of delivery

## Assembly parts

Type h = h <sub>1</sub> [inch]	CN .. 1204 .. 1	CN .. 1606 .. 1,25
Shim	AP301-CN12	AP302-CN16
Screw for shim Tightening torque	FS1461 (T15IP) 1,844 lbs	FS1463 (T20IP) 3,688 lbs
Clamp	PK241	PK242
Screw for clamp Tightening torque	FS1473 (T15IP) 2,876 lbs	FS1474 (T20IP) 4,72 lbs
Pressure spring	FS1470	FS1471
Pin	RS117	RS117
Torx key	FS1465 (T15IP)	
Allen key		FS1464 (T20IP)

## Accessories

Type	CN .. 1204 ..	CN .. 1606 ..
Insert with hole Carbide clamp set	PK241-SET	
(standard assembly parts) Clamp set		PK242-SET
Insert with hole Carbide clamp set	PK245-SET	PK246-SET
Insert with hole Carbide clamp set	PK254-SET	
Shim for CN .. 1207 ..	AP411-CN1207	





# Shank tool – Lever clamping

PCKN

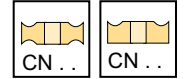
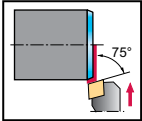
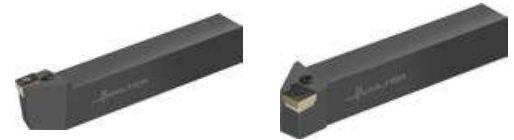

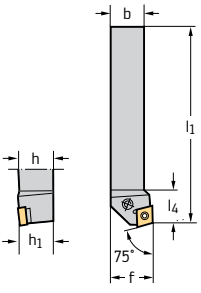
Walter Turn



Tool	Designation		h = h <sub>1</sub> mm	b mm	f mm	l <sub>4</sub> mm	l <sub>1</sub> mm	γ	λ <sub>s</sub>	Type
	PCKNR2525M12		12	25	32	22,9	153,1	-6°	-6°	CN .. 1204 ..
	PCKNL2525M12		12	25	32	22,9	153,1	-6°	-6°	CN .. 1204 ..

Square shank

Dimensional drawing shows right-hand version. | Measured with master insert: CN .. 120408 | Refer to the Walter online catalogue for more product information: [www.walter-tools.com](http://www.walter-tools.com) | Bodies and assembly parts are included in the scope of delivery

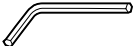
Assembly parts		Type	CN .. 1204 ..
		h = h <sub>1</sub> [mm]	25
	Shim		AP134-CN1216
	Lever		KN102
	Clamping screw		FS352 (SW 3)
	Tightening torque		5 Nm
	Shim pin		RS102
	Tapered assembly pin		MD101
	Allen key		ISO2936-3 (SW 3)

Accessories		Type	CN .. 1204 ..
	Shim		AP134-CN1208

## Shank tool – Lever clamping

PCSN 

Walter Turn

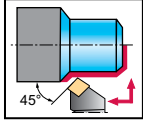
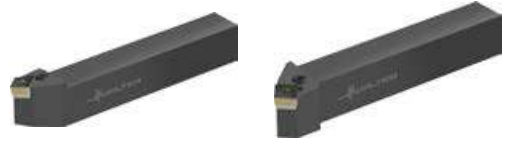

## Tool

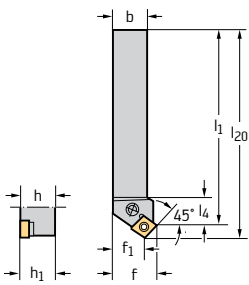

Square shank

Designation		h = h <sub>1</sub> mm	b mm	f mm	f <sub>1</sub> mm	l <sub>1</sub> mm	l <sub>4</sub> mm	l <sub>20</sub> mm	γ	λ <sub>s</sub>	Type
PCSNR2525M12		12	25	32	23,9	150	19,7	160	-8°	-8°	CN .. 1204 ..
PCSNL2525M12		12	25	32	23,9	150	19,7	160	-8°	-8°	CN .. 1204 ..

Dimensional drawing shows right-hand version. | Measured with master insert: CN .. 120408 | Refer to the Walter online catalogue for more product information: [www.walter-tools.com](http://www.walter-tools.com) | Bodies and assembly parts are included in the scope of delivery

## Assembly parts

Type	h = h <sub>1</sub> [mm]	CN .. 1204 ..
	Shim	25
	Lever	AP134-CN1216
	Clamping screw Tightening torque	KN102 FS352 (SW 3) 5 Nm
	Shim pin	RS102
	Tapered assembly pin	MD101
	Allen key	ISO2936-3 (SW 3)

## Accessories

Type	CN .. 1204 ..
	Shim AP134-CN1208

## Shank tool – Rigid clamping

DDHN 

Walter Turn

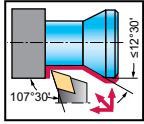

Tool	Designation		h = h <sub>1</sub> mm	b mm	l <sub>1</sub> mm	l <sub>4</sub> mm	f mm	γ	λ <sub>s</sub>	Type
										DN .. 1506 ..
	DDHNR2020K15	15	20	20	125	36,1	25	-6°	-7°	DN .. 1506 ..
	DDHNR2525M15	15	25	25	150	36,1	32	-6°	-7°	
	DDHNL2020K15	15	20	20	125	36,1	25	-6°	-7°	DN .. 1506 ..
	DDHNL2525M15	15	25	25	150	36,1	32	-6°	-7°	

Square shank

Dimensional drawing shows right-hand version. | Measured with master insert: DN .. 150608 | Refer to the Walter online catalogue for more product information: [www.walter-tools.com](http://www.walter-tools.com) | Bodies and assembly parts are included in the scope of delivery

Assembly parts	Type h = h <sub>1</sub> (mm)	DN .. 1506 .. 20-25
	Shim	AP304-DN15
	Screw for shim Tightening torque	FS1461 (T15IP) 2,5 Nm
	Clamp	PK241
	Screw for clamp Tightening torque	FS1473 (T15IP) 3,9 Nm
	Pressure spring	FS1470
	Pin	RS117
	Torx key	FS1465 (T15IP)

Accessories	Type	DN .. 1506 ..
	(standard assembly parts) Clamp set	PK241-SET
	Insert without hole Carbide clamp set	PK245-SET
	Insert without hole Carbide clamp set	PK254-SET
	Shim for DN .. 1504 ..	AP304-DN1504
	Shim for DN .. 1507 ..	AP412-DN1507

## Shank tool – Rigid clamping

DDQN inch

Walter Turn

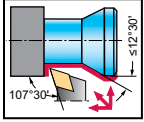

## Tool

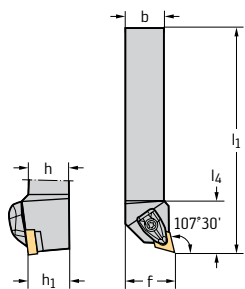

Square shank

Designation		h = h <sub>1</sub> inch	b inch	l <sub>1</sub> inch	l <sub>4</sub> inch	f inch	γ	λ <sub>s</sub>	Type
DDQNR164D		15	1,000	6,000	1,42	1,250	0°	7°	DN .. 1504 .. DN .. 43 ..
DDQNR204D		15	1,250	6,000	1,42	1,500	0°	7°	
DDQNL164D		15	1,000	6,000	1,42	1,250	0°	7°	DN .. 1504 .. DN .. 43 ..
DDQNL204D		15	1,250	6,000	1,42	1,500	0°	7°	

Dimensional drawing shows right-hand version. | Measured with master insert: DN .. 150408 | Refer to the Walter online catalogue for more product information: [www.walter-tools.com](http://www.walter-tools.com) | Bodies and assembly parts are included in the scope of delivery

## Assembly parts

	Type h = h <sub>1</sub> [inch]	DN .. 1504 .. 1-1,25
	Shim	AP304-DN1504
	Screw for shim Tightening torque	FS1461 (T15IP) 1,844 lbs
	Clamp	PK241
	Screw for clamp Tightening torque	FS1473 (T15IP) 2,876 lbs
	Pressure spring	FS1470
	Pin	RS117
	Torx key	FS1465 (T15IP)

## Accessories

	Type	DN .. 1504 ..
	(standard assembly parts) Clamp set	PK241-SET
	Insert without hole Carbide clamp set	PK245-SET
	Insert without hole Carbide clamp set	PK254-SET
	Shim for DN .. 1506 ..	AP304-DN15
	Shim for DN .. 1507 ..	AP412-DN1507

## Shank tool – Rigid clamping

DDJN 

Walter Turn

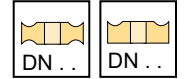
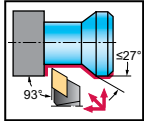
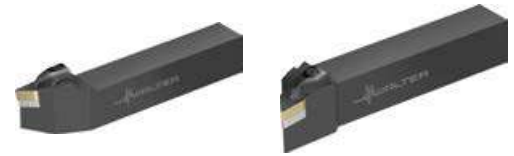

## Tool

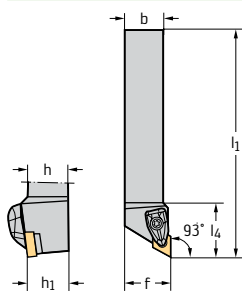

Square shank

Designation

h = h<sub>1</sub>  
mmb  
mml<sub>1</sub>  
mml<sub>4</sub>  
mmf  
mm

γ

λ<sub>s</sub>

Type

Designation	h = h <sub>1</sub> mm	b mm	l <sub>1</sub> mm	l <sub>4</sub> mm	f mm	γ	λ <sub>s</sub>	Type
DDJNR2020K11	11	20	125	30,2	25	-6°	-7°	DN .. 1104 ..
DDJNR2525M11	11	25	150	30,2	32	-6°	-7°	
DDJNR3225P11	11	32	170	30,2	32	-6°	-7°	
DDJNR2020K15	15	20	125	39,4	25	-6°	-7°	DN .. 1506 ..
DDJNR2525M15	15	25	150	39,4	32	-6°	-7°	
DDJNR3225P15	15	32	170	39,4	32	-6°	-7°	
DDJNR3232P15	15	32	170	39,4	40	-6°	-7°	
DDJNL2020K11	11	20	125	30,2	25	-6°	-7°	DN .. 1104 ..
DDJNL2525M11	11	25	150	30,2	32	-6°	-7°	
DDJNL3225P11	11	32	170	30,2	32	-6°	-7°	
DDJNL2020K15	15	20	125	39,4	25	-6°	-7°	DN .. 1506 ..
DDJNL2525M15	15	25	150	39,4	32	-6°	-7°	
DDJNL3225P15	15	32	170	39,4	32	-6°	-7°	
DDJNL3232P15	15	32	170	39,4	40	-6°	-7°	

Dimensional drawing shows right-hand version. | Measured with master insert: DN .. 110408 / DN .. 150608 | Refer to the Walter online catalogue for more product information: [www.walter-tools.com](http://www.walter-tools.com) | Bodies and assembly parts are included in the scope of delivery

## Assembly parts

Type  
h = h<sub>1</sub> [mm]DN .. 1104 ..  
20–32DN .. 1506 ..  
20–32

Type	h = h <sub>1</sub> [mm]	DN .. 1104 .. 20–32	DN .. 1506 .. 20–32
	Shim	AP305-DN11	AP304-DN15
	Screw for shim Tightening torque	FS1462 (T9IP) 1,5 Nm	FS1461 (T15IP) 2,5 Nm
	Clamp	PK240	PK241
	Screw for clamp Tightening torque	FS1472 (T9IP) 1,7 Nm	FS1473 (T15IP) 3,9 Nm
	Pressure spring	FS1469	FS1470
	Pin	RS116	RS117
	Torx key	FS1466 (T9IP)	FS1465 (T15IP)

## Accessories

Type

DN .. 1104 ..

DN .. 1506 ..

Type	DN .. 1104 ..	DN .. 1506 ..
(standard assembly parts) Clamp set	PK240-SET	PK241-SET
Insert without hole Carbide clamp set		PK245-SET
Insert without hole Carbide clamp set		PK254-SET
Shim for DN .. 1504 ..		AP304-DN1504
Shim for DN .. 1507 ..		AP412-DN1507

## Shank tool – Rigid clamping

DDJN inch

Walter Turn

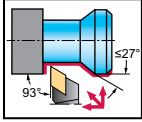

## Tool

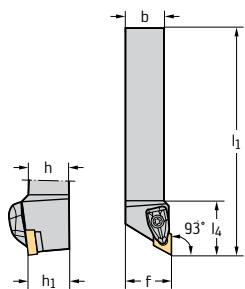







Square shank

Designation		h = h <sub>1</sub> inch	b inch	l <sub>1</sub> inch	l <sub>4</sub> inch	f inch	γ	λ <sub>s</sub>	Type	
DDJNR103A		11	0,625	0,625	4,000	1,195	0,875	-6°	-7°	DN .. 1104 .. DN .. 33 ..
DDJNR123C		11	0,750	0,750	5,000	1,190	1,000	-6°	-7°	
DDJNR163D		11	1,000	1,000	6,000	1,190	1,250	-6°	-7°	
DDJNR124B		15	0,750	0,750	4,500	1,450	1,000	-6°	-7°	DN .. 1504 .. DN .. 43 ..
DDJNR164C		15	1,000	1,000	5,000	1,550	1,250	-6°	-7°	
DDJNR164D		15	1,000	1,000	6,000	1,550	1,250	-6°	-7°	
DDJNR204D		15	1,250	1,250	6,000	1,550	1,500	-6°	-7°	DN .. 1104 .. DN .. 33 ..
DDJNR244D		15	1,500	1,500	6,000	1,550	2,000	-6°	-7°	
DDJNL103A		11	0,625	0,625	4,000	1,195	0,875	-6°	-7°	
DDJNL123C		11	0,750	0,750	5,000	1,190	1,000	-6°	-7°	DN .. 1504 .. DN .. 43 ..
DDJNL163D		11	1,000	1,000	6,000	1,190	1,250	-6°	-7°	
DDJNL124B		15	0,750	0,750	4,500	1,450	1,000	-6°	-7°	
DDJNL164C		15	1,000	1,000	5,000	1,550	1,250	-6°	-7°	DN .. 1104 .. DN .. 33 ..
DDJNL164D		15	1,000	1,000	6,000	1,550	1,250	-6°	-7°	
DDJNL204D		15	1,250	1,250	6,000	1,550	1,500	-6°	-7°	
DDJNL244D		15	1,500	1,500	6,000	1,550	2,000	-6°	-7°	DN .. 1504 .. DN .. 43 ..

Dimensional drawing shows right-hand version. | Measured with master insert: DN .. 110408 / DN .. 150408 | Refer to the Walter online catalogue for more product information: [www.walter-tools.com](http://www.walter-tools.com) | Bodies and assembly parts are included in the scope of delivery

## Assembly parts

	Type h = h <sub>1</sub> [inch]	DN .. 1104 .. 0,625-1	DN .. 1504 .. 0,75-1,5	DN .. 1504 .. 1
	Shim	AP305-DN11	AP304-DN1504	AP304-DN1504
	Screw for shim Tightening torque	FS1462 (T9IP) 1,106 lbs	FS1461 (T15IP) 1,844 lbs	FS1461 (T15IP) 1,844 lbs
	Clamp	PK240	PK241	PK241
	Screw for clamp Tightening torque	FS1472 (T9IP) 1,254 lbs	FS1473 (T15IP) 2,876 lbs	FS1473 (T15IP) 2,876 lbs
	Pressure spring	FS1469	FS1470	FS1470
	Pin	RS116	RS117	RS117
	Torx key	FS1466 (T9IP)	FS1465 (T15IP)	FS1465 (T15IP)

Accessories			
	Type	DN .. 1104 ..	DN .. 1504 ..
	(standard assembly parts) Clamp set	PK240-SET	PK241-SET
	Insert without hole Carbide clamp set		PK245-SET
	Insert without hole Carbide clamp set		PK254-SET
	Shim for DN .. 1504 ..		AP304-DN1504
	Shim for DN . . 1506 . .		AP304-DN15
	Shim for DN .. 1507 ..		AP412-DN1507

## Shank tool – Rigid clamping

DDJN...-P 

## Walter Turn

– Precision cooling

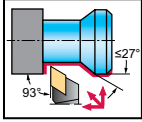

## Tool

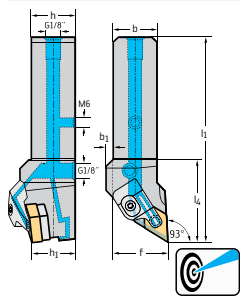

Designation	h = h <sub>1</sub> mm	b mm	b <sub>1</sub> mm	l <sub>1</sub> mm	l <sub>4</sub> mm	f mm	γ	λ <sub>s</sub>	Type	
DDJNR2020X11-P	11	20	20	6	125	48,5	25	-6°	-7°	DN .. 1104 ..
DDJNR2525X11-P	11	25	25	0	140	48,5	32	-6°	-7°	
DDJNR2020X15-P	15	20	20	7	125	48,5	25	-6°	-7°	DN .. 1506 ..
DDJNR2525X15-P	15	25	25	3	140	48,5	32	-6°	-7°	
DDJNL2020X11-P	11	20	20	6	125	48,5	25	-6°	-7°	DN .. 1104 ..
DDJNL2525X11-P	11	25	25	0	140	48,5	32	-6°	-7°	
DDJNL2020X15-P	15	20	20	7	125	48,5	25	-6°	-7°	DN .. 1506 ..
DDJNL2525X15-P	15	25	25	3	140	48,5	32	-6°	-7°	

Square shank

Dimensional drawing shows right-hand version. | Measured with master insert: DN .. 110408 / DN .. 150608 | For the connection set for internal coolant supply with G1/8" thread, see „Assembly parts and accessories“ | The maximum recommended coolant pressure is 150 bar (2175 psi) | Refer to the Walter online catalogue for more product information: [www.walter-tools.com](http://www.walter-tools.com) | Bodies and assembly parts are included in the scope of delivery

## Assembly parts

Type h = h <sub>1</sub> [mm]	DN .. 1104 .. 20–25	DN .. 1506 .. 20–25
Shim	AP305-DN11	AP304-DN15
Screw for shim Tightening torque	FS1462 (T9IP) 1,5 Nm	FS1461 (T15IP) 2,5 Nm
Right clamp	PK261R	PK265R
Left clamp	PK261L	PK265L
Screw for clamp Tightening torque	FS1473 (T15IP) 3,9 Nm	FS1473 (T15IP) 3,9 Nm
Pressure spring	FS2188	FS2188
G 1/8" threaded plug	FS2258 (SW 2)	FS2258 (SW 2)
M6 threaded plug	FS2288 (SW 3)	FS2288 (SW 3)
Torx key	FS1465 (T15IP)	FS1465 (T15IP)

## Accessories

Type	DN .. 1104 ..	DN .. 1506 ..
(standard assembly parts) Right clamp set	PK261R-SET	PK265R-SET
(standard assembly parts) Left clamp set	PK261L-SET	PK265L-SET
Shim for DN .. 1504 ..		AP304-DN1504



# Shank tool – Rigid clamping

DDJN...-P inch

Walter Turn



– Precision cooling

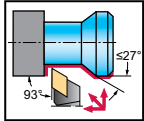

Tool	Designation		h = h <sub>1</sub> inch	b inch	b <sub>1</sub> inch	l <sub>1</sub> inch	l <sub>4</sub> inch	f inch	γ	λ <sub>s</sub>	Type
	DDJNR163D-P	11	1,000	1,000	0,118	6,000	1,909	1,250	-6°	-7°	DN .. 1104 .. DN .. 33 ..
	DDJNR124B-P	15	0,750	0,750	0,276	4,500	1,969	1,000	-6°	-7°	DN .. 1504 .. DN .. 43 ..
	DDJNR164D-P	15	1,000	1,000	0,118	6,000	1,909	1,250	-6°	-7°	DN .. 1104 .. DN .. 33 ..
	DDJNL163D-P	11	1,000	1,000	0,118	6,000	1,909	1,250	-6°	-7°	DN .. 1504 .. DN .. 43 ..
	DDJNL124B-P	15	0,750	0,750	0,276	4,500	1,969	1,000	-6°	-7°	DN .. 1104 .. DN .. 33 ..
	DDJNL164D-P	15	1,000	1,000	0,118	6,000	1,909	1,250	-6°	-7°	DN .. 1504 .. DN .. 43 ..

Square shank

Dimensional drawing shows right-hand version. | Measured with master insert: DN .. 150408 / DN .. 110408 | For the connection set for internal coolant supply with G1/8" thread, see „Assembly parts and accessories“ | The maximum recommended coolant pressure is 150 bar (2175 psi) | Refer to the Walter online catalogue for more product information: [www.walter-tools.com](http://www.walter-tools.com) | Bodies and assembly parts are included in the scope of delivery

Assembly parts		DN .. 1104 .. 1	DN .. 1504 .. 0,75–1
	Shim	AP305-DN11	AP304-DN1504
	Screw for shim Tightening torque	FS1462 (T9IP) 1,106 lbs	FS1461 (T15IP) 1,844 lbs
	Right clamp	PK261R	PK265R
	Left clamp	PK261L	PK265L
	Screw for clamp Tightening torque	FS1473 (T15IP) 2,876 lbs	FS1473 (T15IP) 2,876 lbs
	Pressure spring	FS2188	FS2188
	G 1/8" threaded plug	FS2258 (SW 2)	FS2258 (SW 2)
	M6 threaded plug	FS2288 (SW 3)	FS2288 (SW 3)
	Torx key	FS1465 (T15IP)	FS1465 (T15IP)

Accessories		DN .. 1104 ..	DN .. 1504 ..
	(standard assembly parts) Right clamp set	PK261R-SET	PK265R-SET
	(standard assembly parts) Left clamp set	PK261L-SET	PK265L-SET
	Shim for DN .. 1506 ..		AP304-DN15

## Shank tool – Rigid clamping

DDPN inch

Walter Turn

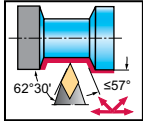

## Tool

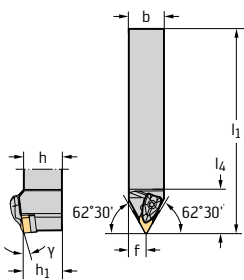

Square shank

## Designation

h = h<sub>1</sub>  
inchb  
inchl<sub>1</sub>  
inchl<sub>4</sub>  
inchf  
inch

γ

λ<sub>s</sub>

Type

DDPNN124B	15	0,750	0,750	4,500	1,610	0,375	-5°	-9°	DN .. 1504 .. DN .. 43 ..
DDPNN164D	15	1,000	1,000	6,000	1,610	0,500	-5°	-9°	
DDPNN204D	15	1,250	1,250	6,000	1,610	0,625	-5°	-9°	

Measured with master insert: DN .. 150408 | Refer to the Walter online catalogue for more product information: [www.walter-tools.com](http://www.walter-tools.com) | Bodies and assembly parts are included in the scope of delivery

## Assembly parts

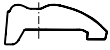
Type  
h = h<sub>1</sub> [inch]DN .. 1504 ..  
0,75–1,25Screw for shim  
Tightening torqueFS1461 (T15IP)  
1,844 lbs

Clamp

PK241

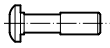
Screw for clamp  
Tightening torqueFS1473 (T15IP)  
2,876 lbs

Pressure spring

FS1470



Pin

RS117



Torx key

FS1465 (T15IP)

## Accessories

Type

DN .. 1504 ..

(standard assembly parts)  
Clamp set

PK241-SET

Insert without hole  
Carbide clamp set

PK245-SET

Insert without hole  
Carbide clamp set

PK254-SET



Shim for DN .. 1504 ..

AP304-DN1504



Shim for DN .. 1507 ..

AP412-DN1507

## Shank tool – Lever clamping

PDJN 

Walter Turn

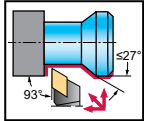

## Tool

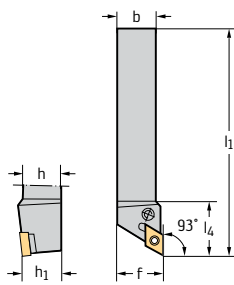

Square shank

Designation		h = h <sub>1</sub> mm	b mm	f mm	l <sub>4</sub> mm	l <sub>1</sub> mm	γ	λ <sub>s</sub>	Type
PDJNR1616H11		11	16	20	29,7	100	-6°	-7°	DN .. 1104 ..
PDJNR2020K11		11	20	25	29,7	125	-6°	-7°	
PDJNR2525M11		11	25	32	29,7	150	-6°	-7°	
PDJNR3225P11		11	32	32	29,7	170	-6°	-7°	
PDJNR2020K15		15	20	25	36,2	125	-6°	-7°	DN .. 1506 ..
PDJNR2525M15		15	25	32	36,2	150	-6°	-7°	
PDJNR3225P15		15	32	32	36,2	170	-6°	-7°	
PDJNR3232P15		15	32	40	36,2	170	-6°	-7°	
PDJNL1616H11		11	16	20	29,7	100	-6°	-7°	DN .. 1104 ..
PDJNL2020K11		11	20	25	29,7	125	-6°	-7°	
PDJNL2525M11		11	25	32	29,7	150	-6°	-7°	
PDJNL3225P11		11	32	32	29,7	170	-6°	-7°	
PDJNL2020K15		15	20	25	36,2	125	-6°	-7°	DN .. 1506 ..
PDJNL2525M15		15	25	32	36,2	150	-6°	-7°	
PDJNL3225P15		15	32	32	36,2	170	-6°	-7°	
PDJNL3232P15		15	32	40	36,2	170	-6°	-7°	

Dimensional drawing shows right-hand version. | Measured with master insert: DN .. 110408 / DN .. 150608 | Refer to the Walter online catalogue for more product information: [www.walter-tools.com](http://www.walter-tools.com) | Bodies and assembly parts are included in the scope of delivery

## Assembly parts

Type h = h <sub>1</sub> (mm)	DN .. 1104 .. 16–32	DN .. 1506 .. 20–32
Shim	AP171-DN1112	AP145-DN1516
Lever	KN119	KN103
Clamping screw Tightening torque	FS351 (SW 2,5) 2 Nm	FS355 (SW 3) 5 Nm
Shim pin	RS101	RS102
Tapered assembly pin	MD101	MD101
Allen key	ISO2936-2,5 (SW 2,5)	ISO2936-3 (SW 3)

## Accessories

Type	DN .. 1104 ..	DN .. 1506 ..
Shim	AP171-DN1108	AP145-DN1508
Shim for DN .. 1504 ..		AP357-DN1508
Shim for DN .. 1504 ..		AP357-DN1516

## Shank tool – Rigid clamping

DDNN 

Walter Turn

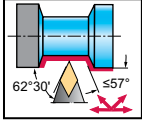

## Tool

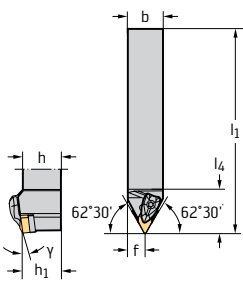

Square shank

## Designation

Designation		h = h <sub>1</sub> mm	b mm	l <sub>1</sub> mm	l <sub>4</sub> mm	f mm	γ	λ <sub>s</sub>	Type
DDNNN2020K11		11	20	125	31,2	10	-5°	-9°	DN .. 1104 ..
DDNNN2525M11		11	25	150	31,2	13	-5°	-9°	
DDNNN2525M15		15	25	150	40,8	13	-5°	-9°	DN .. 1506 ..
DDNNN3225P15		15	32	170	40,8	13	-5°	-9°	

Measured with master insert: DN .. 110408 / DN .. 150608 | Refer to the Walter online catalogue for more product information: [www.walter-tools.com](http://www.walter-tools.com) | Bodies and assembly parts are included in the scope of delivery

## Assembly parts

	Type h = h <sub>1</sub> [mm]	DN .. 1104 .. 20–25	DN .. 1506 .. 25–32
	Shim	AP305-DN11	AP304-DN15
	Screw for shim Tightening torque	FS1462 (T9IP) 1,5 Nm	FS1461 (T15IP) 2,5 Nm
	Clamp	PK240	PK241
	Screw for clamp Tightening torque	FS1472 (T9IP) 1,7 Nm	FS1473 (T15IP) 3,9 Nm
	Pressure spring	FS1469	FS1470
	Pin	RS116	RS117
	Torx key	FS1466 (T9IP)	FS1465 (T15IP)

## Accessories

	Type	DN .. 1104 ..	DN .. 1506 ..
	(standard assembly parts) Clamp set	PK240-SET	PK241-SET
	Insert without hole Carbide clamp set		PK245-SET
	Insert without hole Carbide clamp set		PK254-SET
	Shim for DN .. 1504 ..		AP304-DN1504
	Shim for DN .. 1507 ..		AP412-DN1507

## Shank tool – Rigid clamping

DSBN 

Walter Turn

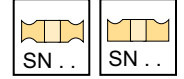
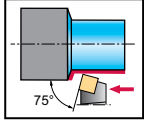

Tool	Designation		h = h <sub>1</sub> mm	b mm	l <sub>1</sub> mm	l <sub>4</sub> mm	f mm	γ	λ <sub>s</sub>	Type
 Square shank	DSBNR2525M12	12	25	25	150	34,3	22	-6°	-6°	SN .. 1204 ..
	DSBNR3225P12	12	32	25	170	34,3	22	-6°	-6°	
	DSBNR3232P15	15	32	32	170	41,5	27	-6°	-6°	SN .. 1506 ..
	DSBNR3232P19	19	32	32	170	46,4	27	-6°	-6°	SN .. 1906 ..
	DSBNR4040S19	19	40	40	250	46,5	35	-6°	-6°	
	DSBNL2525M12	12	25	25	150	34,3	22	-6°	-6°	SN .. 1204 ..
	DSBNL3225P12	12	32	25	170	34,3	22	-6°	-6°	
	DSBNL3232P15	15	32	32	170	41,5	27	-6°	-6°	SN .. 1506 ..
	DSBNL3232P19	19	32	32	170	46,4	27	-6°	-6°	SN .. 1906 ..
	DSBNL4040S19	19	40	40	250	46,5	35	-6°	-6°	

Dimensional drawing shows right-hand version. | Measured with master insert: SN .. 120408 / SN .. 150612 / SN .. 190612 | Refer to the Walter online catalogue for more product information: [www.walter-tools.com](http://www.walter-tools.com) | Bodies and assembly parts are included in the scope of delivery

Assembly parts		SN .. 1204 .. 25–32	SN .. 1506 .. 32	SN .. 1906 .. 32–40
	Shim Type h = h <sub>1</sub> (mm)	AP308-SN12	AP309-SN15	AP310-SN19
	Screw for shim Tightening torque	FS1461 (T15IP) 2,5 Nm	FS1463 (T20IP) 5 Nm	FS1463 (T20IP) 5 Nm
	Clamp	PK241	PK242	PK243
	Screw for clamp Tightening torque	FS1473 (T15IP) 3,9 Nm	FS1474 (T20IP) 6,4 Nm	FS1474 (T20IP) 6,4 Nm
	Pressure spring	FS1470	FS1471	FS1471
	Pin	RS117	RS117	RS117
	Torx key	FS1465 (T15IP)		
	Allen key		FS1464 (T20IP)	FS1464 (T20IP)

Accessories		SN .. 1204 ..	SN .. 1506 ..	SN .. 1906 ..
	(standard assembly parts) Clamp set	PK241-SET	PK242-SET	PK243-SET
	Insert with hole Carbide clamp set	PK245-SET	PK246-SET	
	Insert with hole Carbide clamp set	PK254-SET		
	Shim for SN .. 1207 ..	AP413-SN1207		

## Shank tool – Rigid clamping

DSBN...-P 

Walter Turn



– Precision cooling

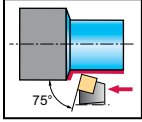

## Tool

Designation		h = h <sub>1</sub> mm	b mm	b <sub>1</sub> mm	h <sub>1</sub> mm	l <sub>4</sub> mm	f mm	γ	λ <sub>s</sub>	Type
DSBNR2525X12-P		12	25	7	135	43,5	22	-6°	-6°	SN .. 1204 ..
DSBNL2525X12-P		12	25	7	135	43,5	22	-6°	-6°	SN .. 1204 ..

Square shank

Dimensional drawing shows right-hand version. | Measured with master insert: SN .. 120408 | For the connection set for internal coolant supply with G1/8" thread, see „Assembly parts and accessories“ | The maximum recommended coolant pressure is 150 bar (2175 psi) | Refer to the Walter online catalogue for more product information: [www.walter-tools.com](http://www.walter-tools.com) | Bodies and assembly parts are included in the scope of delivery

## Assembly parts

Type	h = h <sub>1</sub> [mm]	SN .. 1204 ..
	Shim	AP308-SN12
	Screw for shim Tightening torque	FS1461 (T15IP) 2,5 Nm
	Right clamp	PK265R
	Left clamp	PK265L
	Screw for clamp Tightening torque	FS1473 (T15IP) 3,9 Nm
	Pressure spring	FS2188
	G 1/8" threaded plug	FS2258 (SW 2)
	M6 threaded plug	FS2288 (SW 3)
	Torx key	FS1465 (T15IP)

## Accessories

Type	SN .. 1204 ..
(standard assembly parts) Right clamp set	PK265R-SET
(standard assembly parts) Left clamp set	PK265L-SET

## Shank tool – Rigid clamping

DSRN inch

Walter Turn

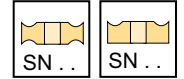
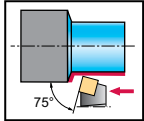

## Tool

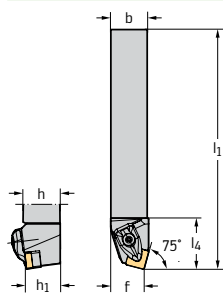

Square shank

Designation		h = h <sub>1</sub> inch	b inch	l <sub>1</sub> inch	l <sub>4</sub> inch	f inch	γ	λ <sub>s</sub>	Type
DSRNR124BM1	12	0,750	0,750	4,500	1,350	0,855	-6°	-6°	SN .. 1204 .. SN .. 43 ..
DSRNR164DM1	12	1,000	1,000	6,000	1,350	1,048	-6°	-6°	
DSRNR165D	15	1,000	1,000	6,000	1,640	1,047	-6°	-6°	SN .. 1506 .. SN .. 54 ..
DSRNR205D	15	1,250	1,250	6,000	1,640	1,291	-6°	-6°	
DSRNR248E	25	1,500	1,500	7,000	2,220	1,697	-6°	-6°	SN .. 2507 .. SN .. 85 ..
DSRNL124BM1	12	0,750	0,750	4,500	1,350	0,855	-6°	-6°	SN .. 1204 .. SN .. 43 ..
DSRNL164DM1	12	1,000	1,000	6,000	1,350	1,048	-6°	-6°	
DSRNL165D	15	1,000	1,000	6,000	1,640	1,047	-6°	-6°	SN .. 1506 .. SN .. 54 ..
DSRNL205D	15	1,250	1,250	6,000	1,640	1,291	-6°	-6°	
DSRNL248E	25	1,500	1,500	7,000	2,220	1,697	-6°	-6°	SN .. 2507 .. SN .. 85 ..

Dimensional drawing shows right-hand version. | Measured with master insert: SN .. 120408 / SN .. 150612 / SN .. 250724 | Refer to the Walter online catalogue for more product information: [www.walter-tools.com](http://www.walter-tools.com) | Bodies and assembly parts are included in the scope of delivery

## Assembly parts

Type h = h <sub>1</sub> [inch]	SN .. 1204 .. 0,75–1	SN .. 1506 .. 1–1,25	SN .. 2507 .. 1,5
Shim	AP308-SN12	AP309-SN15	AP351-SN25
Screw for shim Tightening torque	FS1461 (T15IP) 1,844 lbs	FS1463 (T20IP) 3,688 lbs	FS1589 (T25IP) 7,007 lbs
Clamp	PK241	PK242	PK301
Screw for clamp Tightening torque	FS1473 (T15IP) 2,876 lbs	FS1474 (T20IP) 4,72 lbs	FS1591 (T25IP) 7,007 lbs
Pressure spring	FS1470	FS1471	FS1590
Pin	RS117	RS117	RS117
Torx key	FS1465 (T15IP)		
Allen key		FS1464 (T20IP)	FS1592 (T25IP)

## Accessories

Type	SN .. 1204 ..	SN .. 1506 ..	SN .. 2507 ..
(standard assembly parts) Clamp set	PK241-SET	PK242-SET	PK301-SET
Insert with hole Carbide clamp set	PK245-SET	PK246-SET	
Insert with hole Carbide clamp set	PK254-SET		
Shim for SN .. 1207 ..	AP413-SN1207		

## Shank tool – Lever clamping

PSBN 

Walter Turn

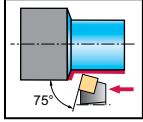

## Tool

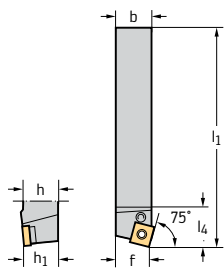

Square shank

Designation		h = h <sub>1</sub> mm	b mm	l <sub>4</sub> mm	l <sub>1</sub> mm	γ	λ <sub>s</sub>	Type	
PSBNR2020K12		12	20	20	27,5	125	-6°	-6°	SN .. 1204 ..
PSBNR2525M12		12	25	25	27,5	150	-6°	-6°	
PSBNR3225P12		12	32	25	27,5	170	-6°	-6°	
PSBNR2525M15		15	25	25	32	150	-6°	-6°	SN .. 1506 ..
PSBNR3232P15		15	32	32	32	170	-6°	-6°	
PSBNR3232P19		19	32	32	39,2	170	-6°	-6°	SN .. 1906 ..
PSBNR4040S19		19	40	40	41,5	250	-6°	-6°	
PSBNR4040S25		25	40	40	47,5	250	-6°	-6°	SN .. 2507 ..
PSBNR5050T25		25	50	50	47,5	300	-6°	-6°	
PSBNL2020K12		12	20	20	27,5	125	-6°	-6°	SN .. 1204 ..
PSBNL2525M12		12	25	25	27,5	150	-6°	-6°	
PSBNL3225P12		12	32	25	27,5	170	-6°	-6°	
PSBNL2525M15		15	25	25	32	150	-6°	-6°	SN .. 1506 ..
PSBNL3232P15		15	32	32	32	170	-6°	-6°	
PSBNL3232P19		19	32	32	39,2	170	-6°	-6°	SN .. 1906 ..
PSBNL4040S19		19	40	40	41,5	250	-6°	-6°	
PSBNL4040S25		25	40	40	47,5	250	-6°	-6°	SN .. 2507 ..
PSBNL5050T25		25	50	50	47,5	300	-6°	-6°	

Dimensional drawing shows right-hand version. | Measured with master insert: SN .. 120408 / SN .. 150612 / SN .. 190612 / SN .. 250724 | Refer to the Walter online catalogue for more product information: [www.walter-tools.com](http://www.walter-tools.com) | Bodies and assembly parts are included in the scope of delivery

## Assembly parts

Type h = h <sub>1</sub> [mm]	SN .. 1204 .. 20-32	SN .. 1506 .. 25-32	SN .. 1906 .. 32-40	SN .. 2507 .. 40-50
Shim	AP141-SN1216	AP142-SN1524	AP143-SN1924	AP144-SN2524
Lever	KN102	KN104	KN106	KN107
Clamping screw Tightening torque	FS352 (SW 3) 5 Nm	FS354 (SW 3) 5 Nm	FS356 (SW 4) 10 Nm	FS357 (SW 5) 14 Nm
Shim pin	RS102	RS103	RS104	RS105
Tapered assembly pin	MD101	MD102	MD102	MD103
Allen key	ISO2936-3 (SW 3)	ISO2936-3 (SW 3)	ISO2936-4 (SW 4)	ISO2936-5 (SW 5)

## Accessories

Type	SN .. 1204 ..	SN .. 1506 ..	SN .. 1906 ..	SN .. 2507 ..
Shim	AP141-SN1208	AP142-SN1516	AP143-SN1912	
Shim for SN .. 2509 ..				AP191-SN250924



## Shank tool – Rigid clamping

DSKN 

Walter Turn

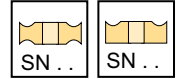
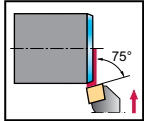

Tool	Designation		h = h <sub>1</sub> mm	b mm	l <sub>1</sub> mm	l <sub>4</sub> mm	f mm	γ	λ <sub>s</sub>	Type
										Square shank
	DSKNR2525M12	12	25	25	150	23,6	32	-6°	-6°	SN .. 1204 ..
	DSKNR3232P15	15	32	32	170	28,9	40	-6°	-6°	SN .. 1506 ..
	DSKNL2525M12	12	25	25	150	23,6	32	-6°	-6°	SN .. 1204 ..
	DSKNL3232P15	15	32	32	170	28,9	40	-6°	-6°	SN .. 1506 ..

Dimensional drawing shows right-hand version. | Measured with master insert: SN .. 120408 / SN .. 150612 | Refer to the Walter online catalogue for more product information: [www.walter-tools.com](http://www.walter-tools.com) | Bodies and assembly parts are included in the scope of delivery

Assembly parts		SN .. 1204 .. 25	SN .. 1506 .. 32
	Shim Type h = h <sub>1</sub> [mm]	AP308-SN12	AP309-SN15
	Screw for shim Tightening torque	FS1461 (T15IP) 2,5 Nm	FS1463 (T20IP) 5 Nm
	Clamp	PK241	PK242
	Screw for clamp Tightening torque	FS1473 (T15IP) 3,9 Nm	FS1474 (T20IP) 6,4 Nm
	Pressure spring	FS1470	FS1471
	Pin	RS117	RS117
	Torx key	FS1465 (T15IP)	
	Allen key		FS1464 (T20IP)

Accessories		SN .. 1204 ..	SN .. 1506 ..
	(standard assembly parts) Clamp set	PK241-SET	PK242-SET
	Insert with hole Carbide clamp set	PK245-SET	PK246-SET
	Insert with hole Carbide clamp set	PK254-SET	
	Shim for SN .. 1207 ..	AP413-SN1207	

## Shank tool – Lever clamping

PSKN 

Walter Turn

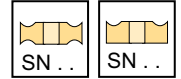
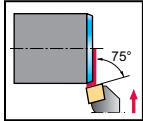

## Tool

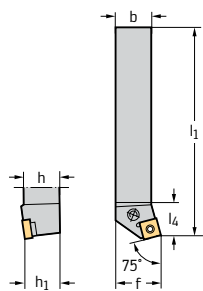

Designation		h = h <sub>1</sub> mm	b mm	f mm	l <sub>4</sub> mm	l <sub>1</sub> mm	γ	λ <sub>s</sub>	Type
PSKNR2020K12		12	20	25	23	128,1	-6°	-6°	SN .. 1204 ..
PSKNR2525M12		12	25	32	23	153,1	-6°	-6°	
PSKNR3232P19		19	32	40	32,4	174,6	-6°	-6°	SN .. 1906 ..
PSKNL2020K12		12	20	25	23	128,1	-6°	-6°	SN .. 1204 ..
PSKNL2525M12		12	25	32	23	153,1	-6°	-6°	
PSKNL3232P19		19	32	40	32,4	174,6	-6°	-6°	SN .. 1906 ..

Square shank

Dimensional drawing shows right-hand version. | Measured with master insert: SN .. 120408 / SN .. 190612 | Refer to the Walter online catalogue for more product information: [www.walter-tools.com](http://www.walter-tools.com) | Bodies and assembly parts are included in the scope of delivery

## Assembly parts

	Type h = h <sub>1</sub> [mm]	SN .. 1204 .. 20–25	SN .. 1906 .. 32
	Shim	AP141-SN1216	AP143-SN1924
	Lever	KN102	KN106
	Clamping screw Tightening torque	FS352 (SW 3) 5 Nm	FS356 (SW 4) 10 Nm
	Shim pin	RS102	RS104
	Tapered assembly pin	MD101	MD102
	Allen key	ISO2936-3 (SW 3)	ISO2936-4 (SW 4)

## Accessories

	Type	SN .. 1204 ..	SN .. 1906 ..
	Shim	AP141-SN1208	AP143-SN1912

## Shank tool – Rigid clamping

DSSN 

Walter Turn

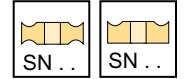
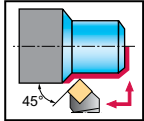

Tool	Designation		h = h <sub>1</sub> mm	b mm	f mm	f <sub>1</sub> mm	h <sub>1</sub> mm	l <sub>4</sub> mm	l <sub>20</sub> mm	γ	λ <sub>s</sub>	Type	
 Square shank	DSSNR2020K12		12	20	20	25	16,7	125	27,5	133,3	-8°	0°	SN .. 1204 ..
	DSSNR2525M12		12	25	25	32	23,7	150	27,5	158,3	-8°	0°	
	DSSNR3225P12		12	32	25	32	23,7	170	27,5	178,3	-8°	0°	
	DSSNR2525M15		15	25	25	32	21,8	150	32	160,2	-8°	0°	SN .. 1506 ..
	DSSNR3232P15		15	32	32	40	29,8	170	32	180,2	-8°	0°	
	DSSNR3232P19		19	32	32	40	27,5	170	37	182,5	-8°	0°	SN .. 1906 ..
	DSSNL2020K12		12	20	20	25	16,7	125	27,5	133,3	-8°	0°	SN .. 1204 ..
	DSSNL2525M12		12	25	25	32	23,7	150	27,5	158,3	-8°	0°	
	DSSNL3225P12		12	32	25	32	23,7	170	27,9	178,3	-8°	0°	
	DSSNL2525M15		15	25	25	32	21,8	150	32	160,2	-8°	0°	SN .. 1506 ..
	DSSNL3232P15		15	32	32	40	29,8	170	32	180,2	-8°	0°	
	DSSNL3232P19		19	32	32	40	27,5	170	37	182,5	-8°	0°	SN .. 1906 ..

Dimensional drawing shows right-hand version. | Measured with master insert: SN .. 120408 / SN .. 150612 / SN .. 190612 | Refer to the Walter online catalogue for more product information: [www.walter-tools.com](http://www.walter-tools.com) | Bodies and assembly parts are included in the scope of delivery

Assembly parts		SN .. 1204 .. 20–32	SN .. 1506 .. 25–32	SN .. 1906 .. 32
	Shim Type h = h <sub>1</sub> [mm]	AP308-SN12	AP309-SN15	AP310-SN19
	Screw for shim Tightening torque	FS1461 (T15IP) 2,5 Nm	FS1463 (T20IP) 5 Nm	FS1463 (T20IP) 5 Nm
	Clamp	PK241	PK242	PK243
	Screw for clamp Tightening torque	FS1473 (T15IP) 3,9 Nm	FS1474 (T20IP) 6,4 Nm	FS1474 (T20IP) 6,4 Nm
	Pressure spring	FS1470	FS1471	FS1471
	Pin	RS117	RS117	RS117
	Torx key	FS1465 (T15IP)		
	Allen key		FS1464 (T20IP)	FS1464 (T20IP)

Accessories		SN .. 1204 ..	SN .. 1506 ..	SN .. 1906 ..
	(standard assembly parts) Clamp set	PK241-SET	PK242-SET	PK243-SET
	Insert with hole Carbide clamp set	PK245-SET	PK246-SET	
	Insert with hole Carbide clamp set	PK254-SET		
	Shim for SN .. 1207 ..	AP413-SN1207		

## Shank tool – Rigid clamping

DSSN inch

Walter Turn

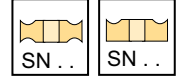
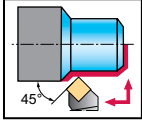

## Tool

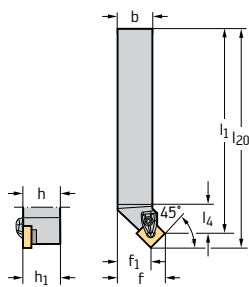

Square shank

Designation		h = h <sub>1</sub> inch	b inch	f inch	f <sub>1</sub> inch	h <sub>1</sub> inch	l <sub>4</sub> inch	l <sub>20</sub> inch	γ	λ <sub>s</sub>	Type	
DSSNR164D		12	1,000	1,000	1,250	0,922	6,000	0,748	6,328	-8°	0°	SN .. 1204 .. SN .. 43 ..
DSSNR165D		15	1,000	1,000	1,250	0,847	6,000	0,898	6,403	-8°	0°	SN .. 1506 .. SN .. 54 ..
DSSNL164D		12	1,000	1,000	1,250	0,922	6,000	0,748	6,328	-8°	0°	SN .. 1204 .. SN .. 43 ..
DSSNL165D		15	1,000	1,000	1,250	0,847	6,000	0,898	6,403	-8°	0°	SN .. 1506 .. SN .. 54 ..

Dimensional drawing shows right-hand version. | Measured with master insert: SN .. 120408 / SN .. 150612 | Refer to the Walter online catalogue for more product information: [www.walter-tools.com](http://www.walter-tools.com) | Bodies and assembly parts are included in the scope of delivery

## Assembly parts

	Type h = h <sub>1</sub> [inch]	SN .. 1204 .. 1	SN .. 1506 .. 1
	Shim	AP308-SN12	AP309-SN15
	Screw for shim Tightening torque	FS1461 (T15IP) 1,844 lbs	FS1463 (T20IP) 3,688 lbs
	Clamp	PK241	PK242
	Screw for clamp Tightening torque	FS1473 (T15IP) 2,876 lbs	FS1474 (T20IP) 4,72 lbs
	Pressure spring	FS1470	FS1471
	Pin	RS117	RS117
	Torx key	FS1465 (T15IP)	
	Allen key		FS1464 (T20IP)

## Accessories

	Type	SN .. 1204 ..	SN .. 1506 ..
	(standard assembly parts) Clamp set	PK241-SET	PK242-SET
	Insert with hole Carbide clamp set	PK245-SET	PK246-SET
	Insert with hole Carbide clamp set	PK254-SET	
	Shim for SN .. 1207 ..	AP413-SN1207	

# Shank tool – Rigid clamping

DSSN...-P mm

**Walter Turn**



– Precision cooling

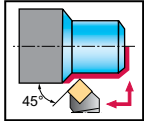

Tool	Designation		h = h <sub>1</sub> mm	b mm	f mm	f <sub>1</sub> mm	l <sub>1</sub> mm	l <sub>4</sub> mm	l <sub>20</sub> mm	γ	λ <sub>s</sub>	Type
	DSSNR2525X12-P	12	25	25	32	23,7	130	48	138,7	-8°	0°	SN .. 1204 ..
	DSSNL2525X12-P	12	25	25	32	23,7	130	48	138,7	-8°	0°	SN .. 1204 ..

Square shank

Dimensional drawing shows right-hand version. | Measured with master insert: SN .. 120408 | For the connection set for internal coolant supply with G1/8" thread, see „Assembly parts and accessories“ | The maximum recommended coolant pressure is 150 bar (2175 psi) | Refer to the Walter online catalogue for more product information: [www.walter-tools.com](http://www.walter-tools.com) | Bodies and assembly parts are included in the scope of delivery

Assembly parts		Type	SN .. 1204 ..
		h = h <sub>1</sub> [mm]	25
	Shim		AP308-SN12
	Screw for shim Tightening torque		FS1461 (T15IP) 2,5 Nm
	Right clamp		PK265R
	Left clamp		PK265L
	Screw for clamp Tightening torque		FS1473 (T15IP) 3,9 Nm
	Pressure spring		FS2188
	G 1/8" threaded plug		FS2258 (SW 2)
	M6 threaded plug		FS2288 (SW 3)
	Torx key		FS1465 (T15IP)

Accessories		Type	SN .. 1204 ..
	(standard assembly parts) Right clamp set		PK265R-SET
	(standard assembly parts) Left clamp set		PK265L-SET

## Shank tool – Lever clamping

PSSN 

Walter Turn

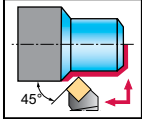

## Tool

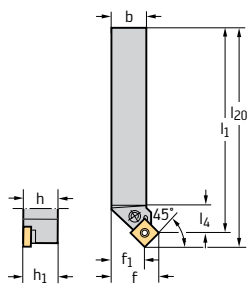

Square shank

Designation		h = h <sub>1</sub> mm	b mm	f mm	f <sub>1</sub> mm	l <sub>1</sub> mm	l <sub>4</sub> mm	l <sub>20</sub> mm	γ	λ <sub>s</sub>	Type
PSSNR1616H09		9	16	20,4	13,9	100	19	106,1	-8°	0°	SN .. 0903 ..
PSSNR2020K12		12	20	25	16,7	125	20,2	133,3	-8°	0°	SN .. 1204 ..
PSSNR2525M12		12	25	32	23,7	150	20,2	158,3	-8°	0°	
PSSNR3225P12		12	32	32	23,7	170	20,2	178,3	-8°	0°	
PSSNR2525M15		15	25	32	21,8	150	25,3	160,2	-8°	0°	SN .. 1506 ..
PSSNR3232P19		19	32	40	27,5	170	28	182,5	-8°	0°	SN .. 1906 ..
PSSNL1616H09		9	16	20,4	13,9	100	19	106,1	-8°	0°	SN .. 0903 ..
PSSNL2020K12		12	20	25	16,7	125	20,2	133,3	-8°	0°	SN .. 1204 ..
PSSNL2525M12		12	25	32	23,7	150	20,2	158,3	-8°	0°	
PSSNL3225P12		12	32	32	23,7	170	25,3	178,3	-8°	0°	
PSSNL2525M15		15	25	32	21,8	150	25,3	160,2	-8°	0°	SN .. 1506 ..
PSSNL3232P19		19	32	40	27,5	170	28	182,5	-8°	0°	SN .. 1906 ..

Dimensional drawing shows right-hand version. | Measured with master insert: SN .. 090308 / SN .. 120408 / SN .. 150612 / SN .. 190612 | Refer to the Walter online catalogue for more product information: [www.walter-tools.com](http://www.walter-tools.com) | Bodies and assembly parts are included in the scope of delivery

## Assembly parts

Type h = h <sub>1</sub> [mm]	SN .. 0903 .. 16	SN .. 1204 .. 20–32	SN .. 1506 .. 25	SN .. 1906 .. 32
Shim	AP409-SN0908	AP141-SN1216	AP142-SN1524	AP143-SN1924
Lever	KN101	KN102	KN104	KN106
Clamping screw Tightening torque	FS351 (SW 2,5) 2 Nm	FS352 (SW 3) 5 Nm	FS354 (SW 3) 5 Nm	FS356 (SW 4) 10 Nm
Shim pin	RS120	RS102	RS103	RS104
Tapered assembly pin	MD101	MD101	MD102	MD102
Allen key	ISO2936-2,5 (SW 2,5)	ISO2936-3 (SW 3)	ISO2936-3 (SW 3)	ISO2936-4 (SW 4)

## Accessories

Type	SN .. 0903 ..	SN .. 1204 ..	SN .. 1506 ..	SN .. 1906 ..
Shim		AP141-SN1208	AP142-SN1516	AP143-SN1912

## Shank tool – Rigid clamping

DSDN 



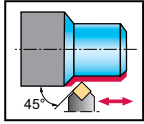

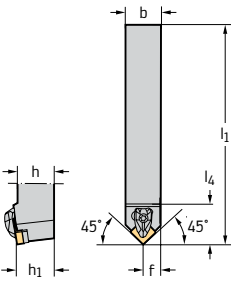

Walter Turn





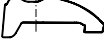

Tool	Designation		h = h <sub>1</sub> mm	b mm	l <sub>1</sub> mm	l <sub>4</sub> mm	f mm	γ	λ <sub>s</sub>	Type
	DSDNN2020K12	12	20	20	125	36,5	10,3	-6°	-6°	SN .. 1204 ..
	DSDNN2525M12	12	25	25	150	36,5	12,8	-6°	-6°	
	DSDNN3225P12	12	32	25	170	36,5	12,8	-6°	-6°	
	DSDNN2525M15	15	25	25	150	44,8	12,8	-6°	-6°	SN .. 1506 ..
	DSDNN3225P19	19	32	25	170	49,5	13	-6°	-6°	SN .. 1906 ..

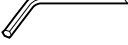
Square shank

Measured with master insert: SN .. 120408 / SN .. 150612 / SN .. 190612 | Refer to the Walter online catalogue for more product information: [www.walter-tools.com](http://www.walter-tools.com) | Bodies and assembly parts are included in the scope of delivery

Assembly parts		SN .. 1204 .. 20–32	SN .. 1506 .. 25	SN .. 1906 .. 32
	Shim	AP308-SN12	AP309-SN15	AP310-SN19
	Screw for shim Tightening torque	FS1461 (T15IP) 2,5 Nm	FS1463 (T20IP) 5 Nm	FS1463 (T20IP) 5 Nm
	Clamp	PK241	PK242	PK243
	Screw for clamp Tightening torque	FS1473 (T15IP) 3,9 Nm	FS1474 (T20IP) 6,4 Nm	FS1474 (T20IP) 6,4 Nm
	Pressure spring	FS1470	FS1471	FS1471
	Pin	RS117	RS117	RS117
	Torx key	FS1465 (T15IP)		
	Allen key		FS1464 (T20IP)	FS1464 (T20IP)

Accessories		SN .. 1204 ..	SN .. 1506 ..	SN .. 1906 ..
	(standard assembly parts) Clamp set	PK241-SET	PK242-SET	PK243-SET
	Insert with hole Carbide clamp set	PK245-SET	PK246-SET	
	Insert with hole Carbide clamp set	PK254-SET		
	Shim for SN .. 1207 ..	AP413-SN1207		

## Shank tool – Rigid clamping

DSDN inch

Walter Turn

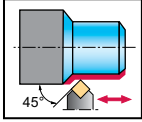

## Tool

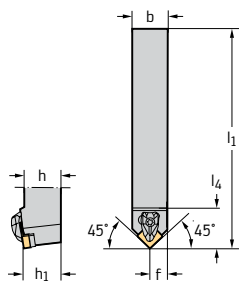

Square shank

Designation		h = h <sub>1</sub> inch	b inch	l <sub>1</sub> inch	l <sub>4</sub> inch	f inch	γ	λ <sub>s</sub>	Type
DSDNN103A		9	0,625	4,000	1,106	0,326	-6°	-6°	SN .. 0903 .. SN .. 32 ..
DSDNN124B		12	0,750	4,500	1,450	0,386	-6°	-6°	SN .. 1204 .. SN .. 43 ..
DSDNN164D		12	1,000	6,000	1,450	0,512	-6°	-6°	
DSDNN204D		12	1,250	6,000	1,450	0,638	-6°	-6°	
DSDNN165D		15	1,000	6,000	1,760	0,520	-6°	-6°	SN .. 1506 .. SN .. 54 ..
DSDNN205D		15	1,250	6,000	1,106	0,326	-6°	-6°	SN .. 1906 .. SN .. 64 ..
DSDNN206D		19	1,250	6,000	1,969	0,646	-6°	-6°	
DSDNN248D		25	1,500	6,000	2,260	0,791	-6°	-6°	SN .. 2507 .. SN .. 85 ..

Measured with master insert: SN .. 090308 / SN .. 120408 / SN .. 150612 / SN .. 150608 / SN .. 190612 / SN .. 250724 | Refer to the Walter online catalogue for more product information: [www.walter-tools.com](http://www.walter-tools.com) | Bodies and assembly parts are included in the scope of delivery

## Assembly parts

Type h = h <sub>1</sub> [inch]	SN .. 0903 .. 0,625	SN .. 1204 .. 0,75–1,25	SN .. 1506 .. 1–1,25	SN .. 1906 .. 1,25	SN .. 2507 .. 1,5
Shim	AP415-SN09	AP308-SN12	AP309-SN15	AP310-SN19	AP351-SN25
Screw for shim Tightening torque	FS1462 (T9IP) 1,106 lbs	FS1461 (T15IP) 1,844 lbs	FS1463 (T20IP) 3,688 lbs	FS1463 (T20IP) 3,688 lbs	FS1589 (T25IP) 7,007 lbs
Clamp	PK240	PK241	PK242	PK243	PK301
Screw for clamp Tightening torque	FS1472 (T9IP) 1,254 lbs	FS1473 (T15IP) 2,876 lbs	FS1474 (T20IP) 4,72 lbs	FS1474 (T20IP) 4,72 lbs	FS1591 (T25IP) 7,007 lbs
Pressure spring	FS1469	FS1470	FS1471	FS1471	FS1590
Pin	RS116	RS117	RS117	RS117	RS117
Torx key	FS1466 (T9IP)	FS1465 (T15IP)			
Allen key			FS1464 (T20IP)	FS1464 (T20IP)	FS1592 (T25IP)

## Accessories

Type	SN .. 0903 ..	SN .. 1204 ..	SN .. 1506 ..	SN .. 1906 ..	SN .. 2507 ..
(standard assembly parts) Clamp set	PK240-SET	PK241-SET	PK242-SET	PK243-SET	PK301-SET
Insert with hole Carbide clamp set		PK245-SET	PK246-SET		
Shim for SN .. 2509 ..					AP351-SN2509
Insert with hole Carbide clamp set		PK254-SET			
Shim for SN .. 1207 ..		AP413-SN1207			



## Shank tool – Lever clamping

PSDN 

Walter Turn

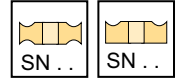
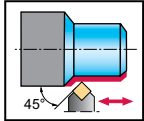

Tool	Designation		h = h <sub>1</sub> mm	b mm	f mm	l <sub>4</sub> mm	l <sub>1</sub> mm	γ	λ <sub>s</sub>	Type
	PSDNN1212F09	9	12	12	6,3	20	80	-6°	-6°	SN .. 0903 ..
	PSDNN1616H09	9	16	16	8,3	21	100	-6°	-6°	
	PSDNN2020K12	12	20	20	10,3	27,6	125	-6°	-6°	SN .. 1204 ..
	PSDNN2525M12	12	25	25	12,8	27,6	150	-6°	-6°	
	PSDNN3225P12	12	32	25	12,8	27,6	170	-6°	-6°	
	PSDNN3225P15	15	32	25	12,5	36	170	-6°	-6°	SN .. 1506 ..
	PSDNN3232P19	19	32	32	16,3	40,4	170	-6°	-6°	SN .. 1906 ..
	PSDNN4040S25	25	40	40	21	48,8	250	-6°	-6°	SN .. 2507 ..

Square shank

Measured with master insert: SN .. 090308 / SN .. 120408 / SN .. 150612 / SN .. 190612 / SN .. 250724 | Refer to the Walter online catalogue for more product information: [www.walter-tools.com](http://www.walter-tools.com) | Bodies and assembly parts are included in the scope of delivery

Assembly parts		SN .. 0903 .. 12	SN .. 0903 .. 16	SN .. 1204 .. 20-32	SN .. 1506 .. 32	SN .. 1906 .. 32	SN .. 2507 .. 40
	Shim Type h = h <sub>1</sub> (mm)		AP409-SN0908	AP141-SN1216	AP142-SN1524	AP143-SN1924	AP144-SN2524
	Lever	KN126	KN101	KN102	KN104	KN106	KN107
	Clamping screw Tightening torque	FS2182 (SW 2) 2 Nm	FS351 (SW 2,5) 2 Nm	FS352 (SW 3) 5 Nm	FS354 (SW 3) 5 Nm	FS356 (SW 4) 10 Nm	FS357 (SW 5) 14 Nm
	Shim pin		RS120	RS102	RS103	RS104	RS105
	Tapered assembly pin		MD101	MD101	MD102	MD102	MD103
	Allen key	ISO2936-2 (SW 2)	ISO2936-2,5 (SW 2,5)	ISO2936-3 (SW 3)	ISO2936-3 (SW 3)	ISO2936-4 (SW 4)	ISO2936-5 (SW 5)

Accessories		SN .. 0903 ..	SN .. 1204 ..	SN .. 1506 ..	SN .. 1906 ..	SN .. 2507 ..
	Shim		AP141-SN1208	AP142-SN1516	AP143-SN1912	AP191-SN250924

## Shank tool – Wedge clamping

MTJN 

Walter Turn

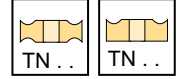
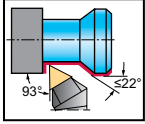
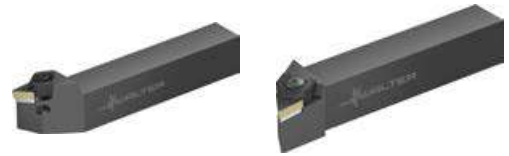

## Tool

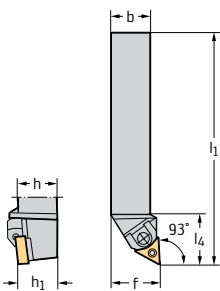

Square shank

Designation		h = h <sub>1</sub> mm	b mm	l <sub>1</sub> mm	l <sub>4</sub> mm	f mm	γ	λ <sub>s</sub>	Type
MTJNR2020K16	16	20	20	125	30,8	25	-6°	-6°	TN .. 1604 ..
MTJNR2525M16	16	25	25	150	30,8	32	-6°	-6°	
MTJNR3225P16	16	32	25	170	30,8	32	-6°	-6°	
MTJNR2525M22	22	25	25	150	34,8	32	-6°	-6°	TN .. 2204 ..
MTJNR3225P22	22	32	25	170	34,8	32	-6°	-6°	
MTJNL2020K16	16	20	20	125	30,8	25	-6°	-6°	TN .. 1604 ..
MTJNL2525M16	16	25	25	150	30,8	32	-6°	-6°	
MTJNL3225P16	16	32	25	170	30,8	32	-6°	-6°	
MTJNL2525M22	22	25	25	150	34,8	32	-6°	-6°	TN .. 2204 ..
MTJNL3225P22	22	32	25	170	34,8	32	-6°	-6°	

Dimensional drawing shows right-hand version. | Measured with master insert: TN .. 160408 / TN .. 220408 | Refer to the Walter online catalogue for more product information: [www.walter-tools.com](http://www.walter-tools.com) | Bodies and assembly parts are included in the scope of delivery

## Assembly parts

Type h = h <sub>1</sub> [mm]	TN .. 1604 .. 20–32	TN .. 2204 .. 25–32
Shim	AP147	AP148
Clamping wedge set	FK303	FK304
Pin	RS106	RS107
Clamping screw Tightening torque	FS358 (SW 3) 5 Nm	FS358 (SW 3) 5 Nm
Allen key	ISO2936-3 (SW 3)	ISO2936-3 (SW 3)

## Accessories

Type	TN .. 1604 ..	TN .. 2204 ..
Shim		AP149

# Shank tool – Rigid clamping

DTFN inch

Walter Turn

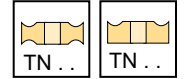
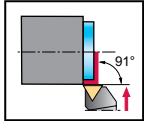

Tool			h = h <sub>1</sub> inch	b inch	l <sub>1</sub> inch	l <sub>4</sub> inch	f inch	γ	λ <sub>s</sub>	Type
<p>Square shank</p>	Designation									
	DTFNR164D	22	1,000	1,000	6,000	1,228	1,250	-6°	-6°	TN .. 2204 .. TN .. 43 ..
	DTFNL164D	22	1,000	1,000	6,000	1,228	1,250	-6°	-6°	TN .. 2204 .. TN .. 43 ..

Dimensional drawing shows right-hand version. | Measured with master insert: TN .. 220408 | Refer to the Walter online catalogue for more product information: [www.walter-tools.com](http://www.walter-tools.com) | Bodies and assembly parts are included in the scope of delivery

Assembly parts		Type	TN .. 2204 ..
		h = h <sub>1</sub> [inch]	1
	Shim		AP322-TN22
	Screw for shim Tightening torque		FS1461 (T15IP) 1,844 lbs
	Clamp		PK241
	Screw for clamp Tightening torque		FS1473 (T15IP) 2,876 lbs
	Pressure spring		FS1470
	Pin		RS117
	Torx key		FS1465 (T15IP)

Accessories		Type	TN .. 2204 ..
	(standard assembly parts) Clamp set		PK241-SET
	Insert without hole Carbide clamp set		PK245-SET
	Insert without hole Carbide clamp set		PK254-SET

## Shank tool – Rigid clamping

DTGN 

Walter Turn

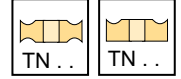
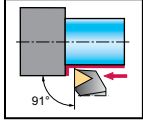

## Tool

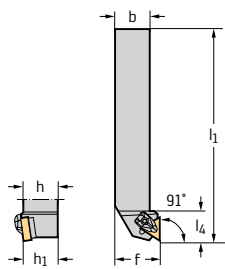

Designation		h = h <sub>1</sub> mm	b mm	l <sub>1</sub> mm	l <sub>4</sub> mm	f mm	γ	λ <sub>s</sub>	Type
DTGNR2020K16		20	20	125	25,4	25	-6°	-6°	TN .. 1604 ..
DTGNR2525M16		25	25	150	24,6	32	-6°	-6°	
DTGNR3225P16		32	25	170	25,3	32	-6°	-6°	
DTGNR2525M22		25	25	150	32,1	32	-6°	-6°	TN .. 2204 ..
DTGNL2020K16		20	20	125	25,4	25	-6°	-6°	TN .. 1604 ..
DTGNL2525M16		25	25	150	24,6	32	-6°	-6°	
DTGNL3225P16		32	25	170	25,3	32	-6°	-6°	
DTGNL2525M22		25	25	150	32,1	32	-6°	-6°	TN .. 2204 ..

Square shank

Dimensional drawing shows right-hand version. | Measured with master insert: TN .. 160408 / TN .. 220408 | Refer to the Walter online catalogue for more product information: [www.walter-tools.com](http://www.walter-tools.com) | Bodies and assembly parts are included in the scope of delivery

## Assembly parts

Type	Type	TN .. 1604 .. 20–32	TN .. 2204 .. 25
	Shim	AP321-TN16	AP322-TN22
	Screw for shim Tightening torque	FS1462 (T9IP) 1,5 Nm	FS1461 (T15IP) 2,5 Nm
	Clamp	PK240	PK241
	Screw for clamp Tightening torque	FS1472 (T9IP) 1,7 Nm	FS1473 (T15IP) 3,9 Nm
	Pressure spring	FS1469	FS1470
	Pin	RS116	RS117
	Torx key	FS1466 (T9IP)	FS1465 (T15IP)

## Accessories

Type	Type	TN .. 1604 ..	TN .. 2204 ..
	(standard assembly parts) Clamp set	PK240-SET	PK241-SET
	Insert without hole Carbide clamp set		PK245-SET
	Insert without hole Carbide clamp set		PK254-SET

## Shank tool – Rigid clamping

DTGN...-P 

Walter Turn



– Precision cooling

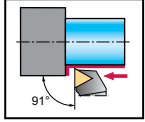

## Tool

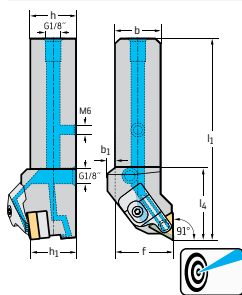

Designation		h = h <sub>1</sub> mm	b mm	b <sub>1</sub> mm	l <sub>1</sub> mm	l <sub>4</sub> mm	f mm	γ	λ <sub>s</sub>	Type
DTGNR2020X16-P		16	20	5	115	38,5	25	-6°	-6°	TN .. 1604 ..
DTGNR2525X16-P		16	25		130	38,5	32	-6°	-6°	
DTGNL2020X16-P		16	20	5	115	38,5	25	-6°	-6°	TN .. 1604 ..
DTGNL2525X16-P		16	25		130	38,5	32	-6°	-6°	

Square shank

Dimensional drawing shows right-hand version. | Measured with master insert: TN .. 160408 | For the connection set for internal coolant supply with G1/8" thread, see „Assembly parts and accessories“ | The maximum recommended coolant pressure is 150 bar (2175 psi) | Refer to the Walter online catalogue for more product information: [www.walter-tools.com](http://www.walter-tools.com) | Bodies and assembly parts are included in the scope of delivery

## Assembly parts

Type	h = h <sub>1</sub> [mm]	TN .. 1604 ..
	Shim	AP321-TN16
	Screw for shim Tightening torque	FS1462 (T9IP) 1,5 Nm
	Left clamp	PK261L
	Right clamp	PK261R
	Screw for clamp Tightening torque	FS1473 (T15IP) 3,9 Nm
	Pressure spring	FS2188
	G 1/8" threaded plug	FS2258 (SW 2)
	M6 threaded plug	FS2288 (SW 3)
	Torx key	FS1465 (T15IP)

## Accessories

Type	TN .. 1604 ..
(standard assembly parts) Left clamp set	PK261L-SET
(standard assembly parts) Right clamp set	PK261R-SET

## Shank tool – Rigid clamping

DTJN inch

Walter Turn

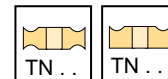
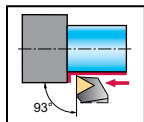

## Tool

Designation		h = h <sub>1</sub> inch	b inch	l <sub>1</sub> inch	l <sub>4</sub> inch	f inch	γ	λ <sub>s</sub>	Type
DTJNR123B		0,750	0,750	4,500	0,953	1,000	-6°	-6°	TN .. 1604 .. TN .. 33 ..
DTJNR163D		1,000	1,000	6,000	0,980	1,250	-6°	-6°	
DTJNR164D		1,000	1,000	6,000	1,283	1,250	-6°	-6°	TN .. 2204 .. TN .. 43 ..
DTJNR205D		1,250	1,250	6,000	1,566	1,500	-6°	-6°	TN .. 2706 .. TN .. 54 ..
DTJNL123B		0,750	0,750	4,500	0,953	1,000	-6°	-6°	TN .. 1604 .. TN .. 33 ..
DTJNL163D		1,000	1,000	6,000	0,980	1,250	-6°	-6°	
DTJNL164D		1,000	1,000	6,000	1,283	1,250	-6°	-6°	TN .. 2204 .. TN .. 43 ..
DTJNL205D		1,250	1,250	6,000	1,566	1,500	-6°	-6°	TN .. 2706 .. TN .. 54 ..

Square shank

Dimensional drawing shows right-hand version. | Measured with master insert: TN .. 160408 / TN .. 220408 / TN .. 270612 | Refer to the Walter online catalogue for more product information: [www.walter-tools.com](http://www.walter-tools.com) | Bodies and assembly parts are included in the scope of delivery

## Assembly parts

Type	Type	TN .. 1604 .. 0,75–1	TN .. 2204 .. 1	TN .. 2706 .. 1,25
	Shim	AP321-TN16	AP322-TN22	AP323-TN27
	Screw for shim		FS1461 (T15IP) 1,844 lbs	FS1463 (T20IP) 3,688 lbs
	Clamping screw Tightening torque	FS1462 (T9IP) 1,106 lbs		
	Clamp	PK240	PK241	PK242
	Screw for clamp Tightening torque	FS1472 (T9IP) 1,254 lbs	FS1473 (T15IP) 2,876 lbs	FS1474 (T20IP) 4,72 lbs
	Pressure spring	FS1469	FS1470	FS1471
	Pin	RS116	RS117	RS117
	Torx key	FS1466 (T9IP)	FS1465 (T15IP)	
	Allen key			FS1464 (T20IP)

## Accessories

Type	Type	TN .. 1604 ..	TN .. 2204 ..	TN .. 2706 ..
	(standard assembly parts) Clamp set	PK240-SET	PK241-SET	PK242-SET
	Insert without hole Carbide clamp set		PK245-SET	
	Insert without hole Carbide clamp set		PK254-SET	

# Shank tool – Lever clamping

PTGN

Walter Turn

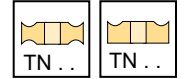
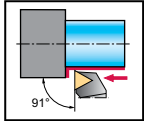

Tool			$h = h_1$ mm	b mm	f mm	$l_4$ mm	$l_1$ mm	$\gamma$	$\lambda_s$	Type
<p>Square shank</p>	Designation									
	PTGNR1616H11		11	16	20	18	100	-6°	-6°	TN .. 1103 ..
	PTGNR1616H16		16	16	20	20,2	100	-6°	-6°	TN .. 1604 ..
	PTGNR2020K16		16	20	25	20,2	125	-6°	-6°	
	PTGNR2525M16		16	25	32	22,2	150	-6°	-6°	
	PTGNR3225P16		16	32	32	22,2	170	-6°	-6°	
	PTGNR4040S27		27	40	50	34	250	-6°	-6°	TN .. 2706 ..
	PTGNL1616H11		11	16	20	18	100	-6°	-6°	TN .. 1103 ..
	PTGNL1616H16		16	16	20	20,2	100	-6°	-6°	TN .. 1604 ..
	PTGNL2020K16		16	20	25	20,2	125	-6°	-6°	
	PTGNL2525M16		16	25	32	22,2	150	-6°	-6°	
	PTGNL3225P16		16	32	32	22,2	170	-6°	-6°	
PTGNL4040S27		27	40	50	34	250	-6°	-6°	TN .. 2706 ..	

Dimensional drawing shows right-hand version. | Measured with master insert: TN .. 110304 / TN .. 160408 / TN .. 270612 | Refer to the Walter online catalogue for more product information: [www.walter-tools.com](http://www.walter-tools.com) | Bodies and assembly parts are included in the scope of delivery

Assembly parts		TN .. 1103 .. 16	TN .. 1604 .. 16-32	TN .. 2706 .. 40
	Shim		AP137-TN1616	AP193-TN2716
	Lever	KN127	KN101	KN125
	Clamping screw Tightening torque	FS2182 (SW 2) 2 Nm	FS351 (SW 2,5) 2 Nm	FS2156 (SW 3) 5 Nm
	Shim pin		RS101	RS103
	Tapered assembly pin		MD101	MD102
	Allen key	ISO2936-2 (SW 2)	ISO2936-2,5 (SW 2,5)	ISO2936-3 (SW 3)

Accessories		TN .. 1103 ..-TN .. 2706 ..	TN .. 1604 ..
	Shim		AP137-TN1608

## Shank tool – Lever clamping

PTFN 

Walter Turn

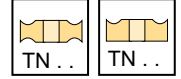
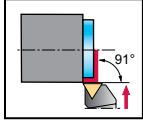

## Tool

Designation		$h = h_1$ mm	$b$ mm	$f$ mm	$l_4$ mm	$l_1$ mm	$\gamma$	$\lambda_s$	Type
PTFNR1616H16		16	16	20	19,7	100	-6°	-6°	TN .. 1604 ..
PTFNR2020K16		16	20	25	20,2	125	-6°	-6°	
PTFNR2525M16		16	25	32	20,2	150	-6°	-6°	
PTFNL1616H16		16	16	20	19,7	100	-6°	-6°	TN .. 1604 ..
PTFNL2020K16		16	20	25	20,2	125	-6°	-6°	
PTFNL2525M16		16	25	32	20,2	150	-6°	-6°	

Square shank

Dimensional drawing shows right-hand version. | Measured with master insert: TN .. 160408 | Refer to the Walter online catalogue for more product information: [www.walter-tools.com](http://www.walter-tools.com) | Bodies and assembly parts are included in the scope of delivery

## Assembly parts

Type	$h = h_1$ [mm]	TN .. 1604 .. 16–25
	Shim	AP137-TN1616
	Lever	KN101
	Clamping screw Tightening torque	FS351 (SW 2,5) 2 Nm
	Shim pin	RS101
	Tapered assembly pin	MD101
	Allen key	ISO2936-2,5 (SW 2,5)

## Accessories

Type	TN .. 1604 ..
	AP137-TN1608



## Shank tool – Rigid clamping

DVPN 

Walter Turn

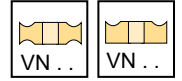
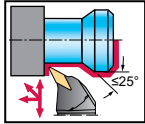

## Tool

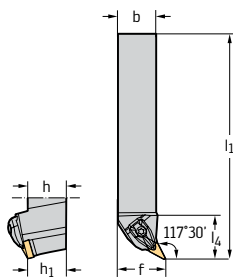

Square shank

Designation

 $h = h_1$   
mmb  
mm $l_1$   
mm $l_4$   
mmf  
mm $\gamma$  $\lambda_s$ 

Type

DVPNR2525M16

16

25

25

150

39,2

32

 $-4^\circ$  $-13^\circ$ 

VN .. 1604 ..

DVPNR3225P16

16

32

25

170

39,2

32

 $-4^\circ$  $-13^\circ$ 

VN .. 1604 ..

DVPNL2525M16

16

25

25

150

39,2

32

 $-4^\circ$  $-13^\circ$ 

VN .. 1604 ..

DVPNL3225P16

16

32

25

170

39,2

32

 $-4^\circ$  $-13^\circ$ 

VN .. 1604 ..

Dimensional drawing shows right-hand version. | Measured with master insert: VN .. 160408 | Refer to the Walter online catalogue for more product information: [www.walter-tools.com](http://www.walter-tools.com) | Bodies and assembly parts are included in the scope of delivery

## Assembly parts

Type  
h = h<sub>1</sub> [mm]VN .. 1604 ..  
25-32

Shim

AP312-VN16

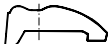
Screw for shim  
Tightening torqueFS1467 (T15IP)  
3 Nm

Clamp

PK244

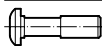
Screw for clamp  
Tightening torqueFS1473 (T15IP)  
3,9 Nm

Pressure spring

FS1470



Pin

RS117



Torx key

FS1465 (T15IP)

## Accessories

Type

VN .. 1604 ..

(standard assembly parts)  
Clamp set

PK244-SET

## Shank tool – Rigid clamping

DVJN 

Walter Turn

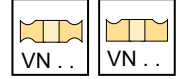
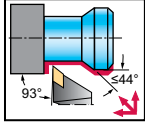

## Tool

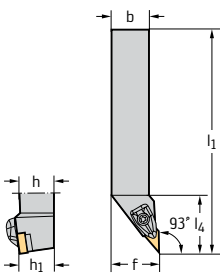

Square shank

Designation		h = h <sub>1</sub> mm	b mm	l <sub>1</sub> mm	l <sub>4</sub> mm	f mm	γ	λ <sub>s</sub>	Type
DVJNR2020K16		16	20	125	46,6	25	-4°	-13°	VN .. 1604 ..
DVJNR2525M16		16	25	150	46,6	32	-4°	-13°	
DVJNR3225P16		16	32	170	46,6	32	-4°	-13°	
DVJNL2020K16		16	20	125	46,6	25	-4°	-13°	VN .. 1604 ..
DVJNL2525M16		16	25	150	46,6	32	-4°	-13°	
DVJNL3225P16		16	32	170	46,6	32	-4°	-13°	

Dimensional drawing shows right-hand version. | Measured with master insert:VN .. 160408 | Refer to the Walter online catalogue for more product information: [www.walter-tools.com](http://www.walter-tools.com) | Bodies and assembly parts are included in the scope of delivery

## Assembly parts

	Type h = h <sub>1</sub> [mm]	VN .. 1604 .. 20-32
	Shim	AP312-VN16
	Screw for shim Tightening torque	FS1467 (T15IP) 3 Nm
	Clamp	PK244
	Screw for clamp Tightening torque	FS1473 (T15IP) 3,9 Nm
	Pressure spring	FS1470
	Pin	RS117
	Torx key	FS1465 (T15IP)

## Accessories

	Type	VN .. 1604 ..
	(standard assembly parts) Clamp set	PK244-SET

## Shank tool – Rigid clamping

DVJN inch

Walter Turn

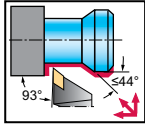

## Tool

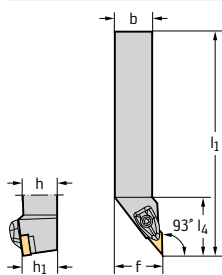

Designation		h = h <sub>1</sub> inch	b inch	l <sub>1</sub> inch	l <sub>4</sub> inch	f inch	γ	λ <sub>s</sub>	Type
DVJNR123B	16	0,750	0,750	4,500	1,830	1,000	-4°	-13°	VN .. 1604 .. VN .. 33 ..
DVJNR163D	16	1,000	1,000	6,000	1,830	1,250	-4°	-13°	
DVJNR203D	16	1,250	1,250	6,000	1,830	1,500	-4°	-13°	
DVJNL123B	16	0,750	0,750	4,500	1,830	1,000	-4°	-13°	VN .. 1604 .. VN .. 33 ..
DVJNL163D	16	1,000	1,000	6,000	1,830	1,250	-4°	-13°	
DVJNL203D	16	1,250	1,250	6,000	1,830	1,500	-4°	-13°	

Square shank

Dimensional drawing shows right-hand version. | Measured with master insert: VN .. 160408 | Refer to the Walter online catalogue for more product information: [www.walter-tools.com](http://www.walter-tools.com) | Bodies and assembly parts are included in the scope of delivery

## Assembly parts

	Type	VN .. 1604 .. 0,75–1,25
	Shim	AP312-VN16
	Screw for shim Tightening torque	FS1467 (T15IP) 2,213 lbs
	Clamp	PK244
	Screw for clamp Tightening torque	FS1473 (T15IP) 2,876 lbs
	Pressure spring	FS1470
	Pin	RS117
	Torx key	FS1465 (T15IP)

## Accessories

	Type	VN .. 1604 ..
	(standard assembly parts) Clamp set	PK244-SET

## Shank tool – Rigid clamping

DVJN...-P 

Walter Turn



– Precision cooling

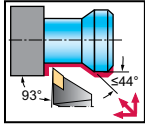

## Tool

Designation		$h = h_1$ mm	b mm	$l_1$ mm	$l_4$ mm	f mm	$\gamma$	$\lambda_s$	Type
DVJNR2020X16-P		16	20	125	48,5	25	-4°	-13°	VN .. 1604 ..
DVJNR2525X16-P		16	25	140	48	32	-4°	-13°	
DVJNL2020X16-P		16	20	125	48,5	25	-4°	-13°	VN .. 1604 ..
DVJNL2525X16-P		16	25	140	48	32	-4°	-13°	

Square shank

Dimensional drawing shows right-hand version. | Measured with master insert: VN .. 160408 | The maximum recommended coolant pressure is 150 bar (2175 psi) | For the connection set for internal coolant supply with G1/8" thread, see „Assembly parts and accessories“ | Refer to the Walter online catalogue for more product information: [www.walter-tools.com](http://www.walter-tools.com) | Bodies and assembly parts are included in the scope of delivery

## Assembly parts

Type	h = h <sub>1</sub> [mm]	VN .. 1604 ..
	Shim	AP312-VN16
	Screw for shim Tightening torque	FS1467 (T15IP) 3 Nm
	Right clamp	PK261R
	Left clamp	PK261L
	Screw for clamp Tightening torque	FS1473 (T15IP) 3,9 Nm
	Pressure spring	FS2188
	G 1/8" threaded plug	FS2258 (SW 2)
	M6 threaded plug	FS2288 (SW 3)
	Torx key	FS1465 (T15IP)

## Accessories

Type	VN .. 1604 ..
(standard assembly parts) Right clamp set	PK261R-SET
(standard assembly parts) Left clamp set	PK261L-SET

# Shank tool – Rigid clamping

DVJN...-P inch

**Walter Turn**



– Precision cooling

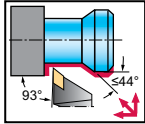

Tool		Designation		h = h <sub>1</sub> inch	b inch	l <sub>1</sub> inch	l <sub>4</sub> inch	f inch	γ	λ <sub>s</sub>	Type
		DVJNR123B-P	16	0,750	0,750	4,496	1,906	1,000	-4°	-13°	VN .. 1604 .. VN .. 33 ..
		DVJNR163D-P	16	1,000	1,000	5,996	1,906	1,250	-4°	-13°	
		DVJNL123B-P	16	0,750	0,750	4,496	1,906	1,000	-4°	-13°	VN .. 1604 .. VN .. 33 ..
		DVJNL163D-P	16	1,000	1,000	5,996	1,906	1,250	-4°	-13°	

Square shank

Dimensional drawing shows right-hand version. | Measured with master insert: VN .. 160408 | For the connection set for internal coolant supply with G1/8" thread, see „Assembly parts and accessories“ | The maximum recommended coolant pressure is 150 bar (2175 psi) | Refer to the Walter online catalogue for more product information: [www.walter-tools.com](http://www.walter-tools.com) | Bodies and assembly parts are included in the scope of delivery

Assembly parts		Type	VN .. 1604 .. 0,75-1
	Shim		AP312-VN16
	Screw for shim Tightening torque		FS1467 (T15IP) 2,213 lbs
	Right clamp		PK261R
	Left clamp		PK261L
	Screw for clamp Tightening torque		FS1473 (T15IP) 2,876 lbs
	Pressure spring		FS2188
	G 1/8" threaded plug		FS2258 (SW 2)
	M6 threaded plug		FS2288 (SW 3)
	Torx key		FS1465 (T15IP)

Accessories		Type	VN .. 1604 ..
	(standard assembly parts) Right clamp set		PK261R-SET
	(standard assembly parts) Left clamp set		PK261L-SET

## Shank tool – Rigid clamping

DVVN 

Walter Turn

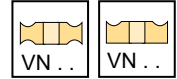
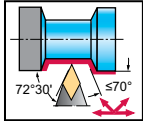

## Tool

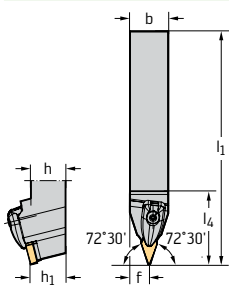

Designation

h = h<sub>1</sub>  
mmb  
mml<sub>1</sub>  
mml<sub>4</sub>  
mmf  
mm

γ

λ<sub>s</sub>

Type

DVVNN2020K16

16

20

20

125

47,8

10,6

-4°

-13°

VN .. 1604 ..

DVVNN2525M16

16

25

25

150

47,8

13,1

-4°

-13°

DVVNN3225P16

16

32

25

170

47,8

13,1

-4°

-13°

Square shank

Measured with master insert: VN .. 160408 | Refer to the Walter online catalogue for more product information: [www.walter-tools.com](http://www.walter-tools.com) | Bodies and assembly parts are included in the scope of delivery

## Assembly parts

Type  
h = h<sub>1</sub> [mm]VN .. 1604 ..  
20–32

Shim

AP312-VN16

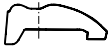
Screw for shim  
Tightening torqueFS1467 (T15IP)  
3 Nm

Clamp

PK244

Screw for clamp  
Tightening torqueFS1473 (T15IP)  
3,9 Nm

Pressure spring

FS1470



Pin

RS117



Torx key

FS1465 (T15IP)

## Accessories

Type

VN .. 1604 ..

(standard assembly parts)  
Clamp set

PK244-SET

## Shank tool – Rigid clamping

DVVN inch

Walter Turn

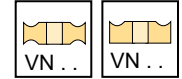
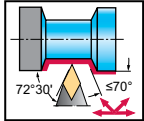

## Tool

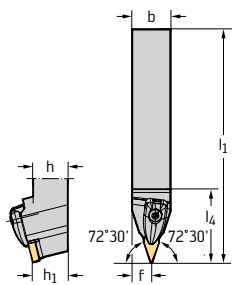

Square shank

Designation

h = h<sub>1</sub>  
inchb  
inchl<sub>1</sub>  
inchl<sub>4</sub>  
inchf  
inch

γ

λ<sub>s</sub>

Type

DVVNN123B	16	0,750	0,750	4,500	1,880	0,398	-4°	-13°	VN .. 1604 .. VN .. 33 ..
DVVNN163D	16	1,000	1,000	6,000	1,880	0,524	-4°	-13°	
DVVNN203D	16	1,250	1,250	6,000	1,880	0,650	-4°	-13°	

Measured with master insert: VN .. 160408 | Refer to the Walter online catalogue for more product information: [www.walter-tools.com](http://www.walter-tools.com) | Bodies and assembly parts are included in the scope of delivery

## Assembly parts

Type  
h = h<sub>1</sub> [inch]VN .. 1604 ..  
0,75-1,25

Shim

AP312-VN16

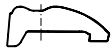
Screw for shim  
Tightening torqueFS1467 (T15IP)  
2,213 lbs

Clamp

PK244

Screw for clamp  
Tightening torqueFS1473 (T15IP)  
2,876 lbs

Pressure spring

FS1470



Pin

RS117



Torx key

FS1465 (T15IP)

## Accessories

Type

VN .. 1604 ..

(standard assembly parts)  
Clamp set

PK244-SET

## Shank tool – Rigid clamping

DVTN inch

Walter Turn

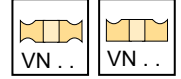
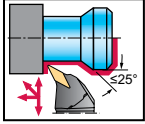

## Tool

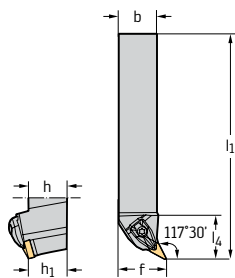

Square shank

Designation		$h = h_1$ inch	$b$ inch	$l_1$ inch	$l_4$ inch	$f$ inch	$\gamma$	$\lambda_s$	Type
DVTNR123B		0,750	0,750	4,500	1,543	1,000	-4°	-13°	VN .. 1604 .. VN .. 33 ..
DVTNR163D		1,000	1,000	6,000	1,544	1,250	-4°	-13°	
DVTNR203D		1,250	1,250	6,000	1,544	1,500	-4°	-13°	
DVTNL123B		0,750	0,750	4,500	1,543	1,000	-4°	-13°	VN .. 1604 .. VN .. 33 ..
DVTNL163D		1,000	1,000	6,000	1,544	1,250	-4°	-13°	
DVTNL203D		1,250	1,250	6,000	1,544	1,500	-4°	-13°	

Dimensional drawing shows right-hand version. | Measured with master insert: VN .. 160408 | Refer to the Walter online catalogue for more product information: [www.walter-tools.com](http://www.walter-tools.com) | Bodies and assembly parts are included in the scope of delivery

## Assembly parts

	Type $h = h_1$ [inch]	VN .. 1604 .. 0,75–1,25
	Shim	AP312-VN16
	Screw for shim Tightening torque	FS1467 (T15IP) 2,213 lbs
	Clamp	PK244
	Screw for clamp Tightening torque	FS1473 (T15IP) 2,876 lbs
	Pressure spring	FS1470
	Pin	RS117
	Torx key	FS1465 (T15IP)

## Accessories

	Type	VN .. 1604 ..
	(standard assembly parts) Clamp set	PK244-SET



## Shank tool – Rigid clamping

DWLN 

Walter Turn

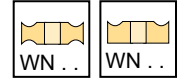
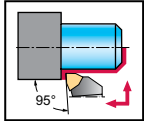

## Tool

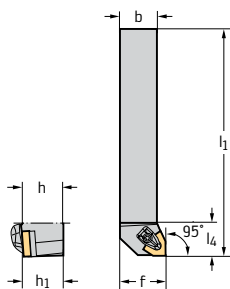

Square shank

Designation		$h = h_1$ mm	b mm	$l_1$ mm	$l_4$ mm	f mm	$\gamma$	$\lambda_s$	Type
DWLN1616H06		6	16	100	26,4	20	-6°	-6°	WN .. 0604 ..
DWLN2020K06		6	20	125	27,1	25	-6°	-6°	
DWLN2525M06		6	25	150	27,1	32	-6°	-6°	
DWLN2020K08		8	20	125	34,3	25	-6°	-6°	WN .. 0804 ..
DWLN2525M08		8	25	150	35	32	-6°	-6°	
DWLN3225P08		8	32	170	35	32	-6°	-6°	
DWLN2525M10		10	25	150	40,3	32	-6°	-6°	WN .. 1006 ..
DWLN3225P10		10	32	170	40,3	32	-6°	-6°	
DWLN3232P10		10	32	170	41,8	40	-6°	-6°	
DWLN1616H06		6	16	100	26,4	20	-6°	-6°	WN .. 0604 ..
DWLN2020K06		6	20	125	27,1	25	-6°	-6°	
DWLN2525M06		6	25	150	27,1	32	-6°	-6°	
DWLN2020K08		8	20	125	34,3	25	-6°	-6°	WN .. 0804 ..
DWLN2525M08		8	25	150	35	32	-6°	-6°	
DWLN3225P08		8	32	170	35	32	-6°	-6°	
DWLN2525M10		10	25	150	40,3	32	-6°	-6°	WN .. 1006 ..
DWLN3225P10		10	32	170	40,3	32	-6°	-6°	
DWLN3232P10		10	32	170	41,8	40	-6°	-6°	

Dimensional drawing shows right-hand version. | Measured with master insert: WN .. 060408 / WN .. 080408 / WN .. 100612 | Refer to the Walter online catalogue for more product information: [www.walter-tools.com](http://www.walter-tools.com) | Bodies and assembly parts are included in the scope of delivery

## Assembly parts

Type $h = h_1$ [mm]	WN .. 0604 .. 16-25	WN .. 0804 .. 20-32	WN .. 1006 .. 25-32
Shim	AP306-WN06	AP307-WN08	AP311-WN10
Screw for shim Tightening torque	FS1462 (T9IP) 1,5 Nm	FS1461 (T15IP) 2,5 Nm	FS1463 (T20IP) 5 Nm
Clamp	PK240	PK241	PK242
Screw for clamp Tightening torque	FS1472 (T9IP) 1,7 Nm	FS1473 (T15IP) 3,9 Nm	FS1474 (T20IP) 6,4 Nm
Pressure spring	FS1469	FS1470	FS1471
Pin	RS116	RS117	RS117
Torx key	FS1466 (T9IP)	FS1465 (T15IP)	
Allen key			FS1464 (T20IP)

## Accessories

Type	WN .. 0604 ..	WN .. 0804 ..	WN .. 1006 ..
(standard assembly parts) Clamp set	PK240-SET	PK241-SET	PK242-SET
Insert with hole Carbide clamp set		PK245-SET	PK246-SET
Insert with hole Carbide clamp set		PK254-SET	

### Shank tool – Rigid clamping

DWLN inch

Walter Turn

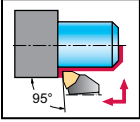

#### Tool

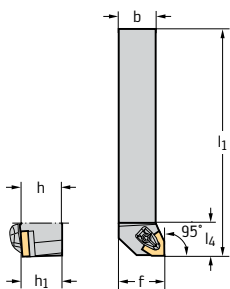

Square shank

Designation		h = h <sub>1</sub> inch	b inch	l <sub>1</sub> inch	l <sub>4</sub> inch	f inch	γ	λ <sub>s</sub>	Type
DWLNR123C	6	0,750	0,750	5,000	1,950	1,000	-6°	-6°	WN .. 0604 .. WN .. 33 ..
DWLNR163D	6	1,000	1,000	6,000	1,950	1,250	-6°	-6°	
DWLNR124C	8	0,750	0,750	5,000	1,378	1,000	-6°	-6°	WN .. 0804 .. WN .. 43 ..
DWLNR164D	8	1,000	1,000	6,000	1,35	1,250	-6°	-6°	
DWLNR204D	8	1,250	1,250	6,000	1,378	1,500	-6°	-6°	
DWLNR165D	10	1,000	1,000	6,000	1,54	1,000	-6°	-6°	WN .. 1006 .. WN .. 54 ..
DWLNL123C	6	0,750	0,750	5,000	1,950	1,000	-6°	-6°	WN .. 0604 .. WN .. 33 ..
DWLNL163D	6	1,000	1,000	6,000	1,950	1,250	-6°	-6°	
DWLNL124C	8	0,750	0,750	5,000	1,378	1,000	-6°	-6°	WN .. 0804 .. WN .. 43 ..
DWLNL164D	8	1,000	1,000	6,000	1,35	1,250	-6°	-6°	
DWLNL204D	8	1,250	1,250	6,000	1,378	1,500	-6°	-6°	
DWLNL165D	10	1,000	1,000	6,000	1,54	1,000	-6°	-6°	WN .. 1006 .. WN .. 54 ..

Dimensional drawing shows right-hand version. | Measured with master insert: WN .. 060408 / WN .. 080408 / WN .. 100612 | Refer to the Walter online catalogue for more product information: [www.walter-tools.com](http://www.walter-tools.com) | Bodies and assembly parts are included in the scope of delivery

#### Assembly parts

Type	Type h = h <sub>1</sub> [inch]	WN .. 0604 .. 0,75–1	WN .. 0804 .. 0,75–1,25	WN .. 1006 .. 1
	Shim	AP306-WN06	AP307-WN08	AP311-WN10
	Screw for shim Tightening torque	FS1462 (T9IP) 1,106 lbs	FS1461 (T15IP) 1,844 lbs	FS1463 (T20IP) 3,688 lbs
	Clamp	PK240	PK241	PK242
	Screw for clamp Tightening torque	FS1472 (T9IP) 1,254 lbs	FS1473 (T15IP) 2,876 lbs	FS1474 (T20IP) 4,72 lbs
	Pressure spring	FS1469	FS1470	FS1471
	Pin	RS116	RS117	RS117
	Torx key	FS1466 (T9IP)	FS1465 (T15IP)	
	Allen key			FS1464 (T20IP)

#### Accessories

Type	Type	WN .. 0604 ..	WN .. 0804 ..	WN .. 1006 ..
	(standard assembly parts) Clamp set	PK240-SET	PK241-SET	PK242-SET
	Insert with hole Carbide clamp set		PK245-SET	PK246-SET
	Insert with hole Carbide clamp set		PK254-SET	

## Shank tool – Rigid clamping

DWLN...-P 

Walter Turn



– Precision cooling

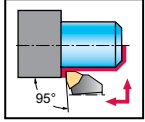

## Tool

Designation		h = h <sub>1</sub> mm	b mm	b <sub>1</sub> mm	l <sub>1</sub> mm	l <sub>4</sub> mm	f mm	γ	λ <sub>s</sub>	Type
DWLN2020X08-P		8	20	0	120	43,5	25	-6,5°	-5,5°	WN .. 0804 ..
DWLN2525X08-P		8	25	0	135	43,5	32	-6,5°	-5,5°	
DWLN2020X08-P		8	20	0	120	43,5	25	-6,5°	-5,5°	WN .. 0804 ..
DWLN2525X08-P		8	25	0	135	43,5	32	-6,5°	-5,5°	

Square shank

Dimensional drawing shows right-hand version. | Measured with master insert: WN .. 080408 | For the connection set for internal coolant supply with G1/8" thread, see „Assembly parts and accessories“ | The maximum recommended coolant pressure is 150 bar (2175 psi) | Refer to the Walter online catalogue for more product information: [www.walter-tools.com](http://www.walter-tools.com) | Bodies and assembly parts are included in the scope of delivery

## Assembly parts

Type	h = h <sub>1</sub> [mm]	WN .. 0804 ..
	Shim	AP307-WN08
	Screw for shim Tightening torque	FS1461 (T15IP) 2,5 Nm
	Right clamp	PK266R
	Left clamp	PK266L
	Screw for clamp Tightening torque	FS1473 (T15IP) 3,9 Nm
	Pressure spring	FS2188
	G 1/8" threaded plug	FS2258 (SW 2)
	M6 threaded plug	FS2288 (SW 3)
	Torx key	FS1465 (T15IP)

## Accessories

Type	WN .. 0804 ..	
	(standard assembly parts) Right clamp set	PK266R-SET
	(standard assembly parts) Left clamp set	PK266L-SET

## Shank tool – Rigid clamping

DWLN...-P inch

Walter Turn



– Precision cooling

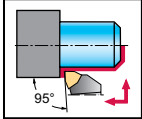

## Tool

Designation	8	$h = h_1$ inch	b inch	$b_1$ inch	$h_1$ inch	$l_4$ inch	f inch	$\gamma$	$\lambda_s$	Type
DWLN124B-P		0,750	0,750	0	4,500	1,713	1,000	-5,5°	-6°	WN .. 0804 .. WN .. 43 ..
DWLN164D-P		1,000	1,000	0	6,000	1,713	1,250	-6,5°	-5,5°	
DWLN124B-P		0,750	0,750	0	4,500	1,713	1,000	-5,5°	-6°	WN .. 0804 .. WN .. 43 ..
DWLN164D-P		1,000	1,000	0	6,000	1,713	1,250	-6,5°	-5,5°	

Square shank

Dimensional drawing shows right-hand version. | Measured with master insert: WN .. 080408 | The maximum recommended coolant pressure is 150 bar (2175 psi) | For the connection set for internal coolant supply with G1/8" thread, see „Assembly parts and accessories“ | Refer to the Walter online catalogue for more product information: [www.walter-tools.com](http://www.walter-tools.com) | Bodies and assembly parts are included in the scope of delivery

## Assembly parts

Type	h = h <sub>1</sub> [inch]	WN .. 0804 .. 0,75–1
Shim		AP307-WN08
Screw for shim Tightening torque		FS1461 (T15IP) 1,844 lbs
Right clamp		PK266R
Left clamp		PK266L
Screw for clamp Tightening torque		FS1473 (T15IP) 2,876 lbs
Pressure spring		FS2188
G 1/8" threaded plug		FS2258 (SW 2)
M6 threaded plug		FS2288 (SW 3)
Torx key		FS1465 (T15IP)

## Accessories

Type	WN .. 0804 ..
(standard assembly parts) Right clamp set	PK266R-SET
(standard assembly parts) Left clamp set	PK266L-SET

## Shank tool – Lever clamping

PWLN 

Walter Turn

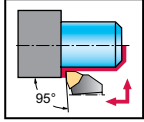

## Tool

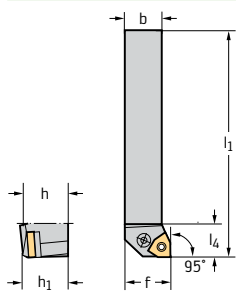

Square shank

Designation		h = h <sub>1</sub> mm	b mm	f mm	l <sub>4</sub> mm	l <sub>1</sub> mm	γ	λ <sub>s</sub>	Type
PWLN1616H06		6	16	20	18,5	100	-6°	-6°	WN .. 0604 ..
PWLN2020K06		6	20	25	18,5	125	-6°	-6°	
PWLN2525M06		6	25	32	18,5	150	-6°	-6°	
PWLN2020K08		8	20	25	22	125	-6°	-6°	WN .. 0804 ..
PWLN2525M08		8	25	32	22	150	-6°	-6°	
PWLN3225P08		8	32	32	22	170	-6°	-6°	
PWLN2525M10		10	25	32	22	150	-6°	-6°	WN .. 1006 ..
PWLN3225P10		10	32	32	22	170	-6°	-6°	
PWLN1616H06		6	16	20	18,5	100	-6°	-6°	WN .. 0604 ..
PWLN2020K06		6	20	25	18,5	125	-6°	-6°	
PWLN2525M06		6	25	32	18,5	150	-6°	-6°	
PWLN2020K08		8	20	25	22	125	-6°	-6°	WN .. 0804 ..
PWLN2525M08		8	25	32	22	150	-6°	-6°	
PWLN3225P08		8	32	32	22	170	-6°	-6°	
PWLN2525M10		10	25	32	22	150	-6°	-6°	WN .. 1006 ..
PWLN3225P10		10	32	32	22	170	-6°	-6°	

Dimensional drawing shows right-hand version. | Measured with master insert: WN .. 060408 / WN .. 080408 / WN .. 100612 | Refer to the Walter online catalogue for more product information: [www.walter-tools.com](http://www.walter-tools.com) | Bodies and assembly parts are included in the scope of delivery

## Assembly parts

Type h = h <sub>1</sub> (mm)	WN .. 0604 .. 16–25	WN .. 0804 .. 20–32	WN .. 1006 .. 25–32
Shim	AP172-WN0612	AP170-WN0816	AP174-WN1016
Lever	KN101	KN102	KN104
Clamping screw Tightening torque	FS351 (SW 2,5) 2 Nm	FS352 (SW 3) 5 Nm	FS354 (SW 3) 5 Nm
Shim pin	RS101	RS102	RS103
Tapered assembly pin	MD101	MD101	MD102
Allen key	ISO2936-2,5 (SW 2,5)	ISO2936-3 (SW 3)	ISO2936-3 (SW 3)

## Accessories

Type	WN .. 0604 ..–WN .. 1006 ..	WN .. 0804 ..
Shim		AP170-WN0808

## Shank tool – Screw clamping

SCLC 

Walter Turn

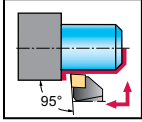

## Tool

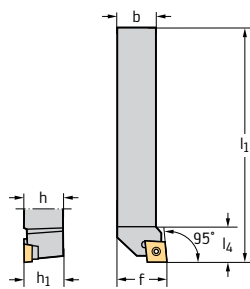

Square shank

Designation		h = h <sub>1</sub> mm	b mm	f mm	l <sub>1</sub> mm	l <sub>4</sub> mm	γ	λ <sub>s</sub>	Type
SCLCR1010E06		6	10	12	70	11	0°	0°	CC .. 0602 ..
SCLCR1212F06		6	12	16	80	10	0°	0°	
SCLCR1616H06		6	16	20	100	12	0°	0°	
SCLCR2020K06		6	20	25	125	12	0°	0°	
SCLCR1212F09		9	12	16	80	15,6	0°	0°	CC .. 09T3 ..
SCLCR1616H09		9	16	20	100	16,8	0°	0°	
SCLCR2020K09		9	20	25	125	17,8	0°	0°	
SCLCR2525M09		9	25	32	150	17	0°	0°	
SCLCR2020K12		12	20	25	125	21,7	0°	0°	CC .. 1204 ..
SCLCR2525M12		12	25	32	150	23,7	0°	0°	
SCLCL1010E06		6	10	12	70	11	0°	0°	CC .. 0602 ..
SCLCL1212F06		6	12	16	80	10	0°	0°	
SCLCL1616H06		6	16	20	100	12	0°	0°	
SCLCL2020K06		6	20	25	125	12	0°	0°	
SCLCL1212F09		9	12	16	80	15,6	0°	0°	CC .. 09T3 ..
SCLCL1616H09		9	16	20	100	16,8	0°	0°	
SCLCL2020K09		9	20	25	125	17,8	0°	0°	
SCLCL2525M09		9	25	32	150	17	0°	0°	
SCLCL2020K12		12	20	25	125	21,7	0°	0°	CC .. 1204 ..
SCLCL2525M12		12	25	32	150	23,7	0°	0°	

Dimensional drawing shows right-hand version. | Measured with master insert: CC .. 060204 / CC .. 09T308 / CC .. 120408 | Refer to the Walter online catalogue for more product information: [www.walter-tools.com](http://www.walter-tools.com) | Bodies and assembly parts are included in the scope of delivery

## Assembly parts

Type h = h <sub>1</sub> [mm]	CC .. 0602 .. 10–20	CC .. 09T3 .. 12	CC .. 09T3 .. 16–25	CC .. 1204 .. 20–25
Clamping screw for indexable insert Tightening torque	FS2061 (T7IP) 0,9 Nm	FS2063 (T15IP) 3 Nm	FS2060 (T15IP) 3 Nm	FS2065 (T15IP) 3 Nm
Shim			AP313-CC0908	AP314-CC1212
Screw for shim			FS2068 (SW 3,5)	FS2069 (SW 4)
Torx key	FS1490 (T7IP)	FS1465 (T15IP)	FS1465 (T15IP)	FS1496 (T15IP)

# Shank tool – Screw clamping

SCLC inch

Walter Turn

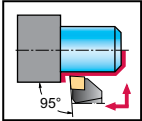

## Tool

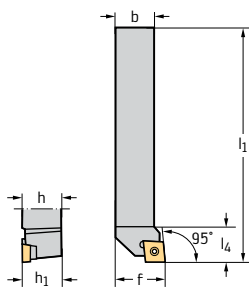

Square shank

Designation		h = h <sub>1</sub> inch	b inch	f inch	l <sub>1</sub> inch	l <sub>4</sub> inch	γ	λ <sub>s</sub>	Type
SCLCR062		6	0,375	0,375	0,500	2,500	0°	0°	CC .. 0602 .. CC .. 2(1.5) ..
SCLCR082B		6	0,500	0,500	0,625	4,500	0°	0°	
SCLCR083		9	0,500	0,500	0,625	3,500	0°	0°	CC .. 09T3 .. CC .. 3(2.5) ..
SCLCR103		9	0,625	0,625	0,750	4,000	0°	0°	
SCLCR123B		9	0,750	0,750	1,000	4,500	0°	0°	
SCLCR163D		9	1,000	1,000	1,250	6,000	0°	0°	
SCLCR164D		12	1,000	1,000	1,250	6,000	0°	0°	CC .. 1204 .. CC .. 43 ..
SCLCR204D		12	1,250	1,250	1,500	6,000	0°	0°	
SCLCL062		6	0,375	0,375	0,500	2,500	0°	0°	CC .. 0602 .. CC .. 2(1.5) ..
SCLCL082B		6	0,500	0,500	0,625	4,500	0°	0°	
SCLCL083		9	0,500	0,500	0,625	3,500	0°	0°	CC .. 09T3 .. CC .. 3(2.5) ..
SCLCL103		9	0,625	0,625	0,750	4,000	0°	0°	
SCLCL123B		9	0,750	0,750	1,000	4,500	0°	0°	
SCLCL163D		9	1,000	1,000	1,250	6,000	0°	0°	
SCLCL164D		12	1,000	1,000	1,250	6,000	0°	0°	CC .. 1204 .. CC .. 43 ..
SCLCL204D		12	1,250	1,250	1,500	6,000	0°	0°	

Dimensional drawing shows right-hand version. | Measured with master insert: CC .. 060204 / CC .. 09T308 / CC .. 09T304 / CC .. 120408 | Refer to the Walter online catalogue for more product information: [www.walter-tools.com](http://www.walter-tools.com) | Bodies and assembly parts are included in the scope of delivery

## Assembly parts

	Type h = h <sub>1</sub> [inch]	CC .. 0602 .. 0,375–0,5	CC .. 09T3 .. 0,5	CC .. 09T3 .. 0,625–1	CC .. 1204 .. 1–1,25
	Clamping screw for indexable insert Tightening torque	FS2061 (T7IP) 0,664 lbs	FS2063 (T15IP) 2,213 lbs	FS2060 (T15IP) 2,213 lbs	FS2065 (T15IP) 2,213 lbs
	Shim			AP313-CC0908	AP314-CC1212
	Screw for shim			FS2068 (SW 3,5)	FS2069 (SW 4)
	Torx key	FS1490 (T7IP)	FS1465 (T15IP)	FS1465 (T15IP)	FS1496 (T15IP)

## Shank tool – Screw clamping

SCLC...-P 

## Walter Turn

– Precision cooling

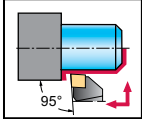

## Tool

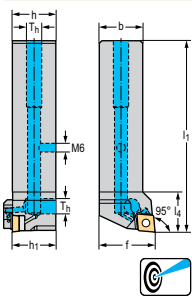

Designation	h = h <sub>1</sub> mm	b mm	f mm	h <sub>1</sub> mm	l <sub>4</sub> mm	γ	λ <sub>s</sub>	T <sub>h</sub>	Type
SCLCR2020X09-P	9	20	25	95	18,5	0°	0°	G1/8"	CC .. 09T3 ..
SCLCR2525X09-P	9	25	25	110	18,5	0°	0°	G1/8"	
SCLCL2020X09-P	9	20	25	95	18,5	0°	0°	G1/8"	CC .. 09T3 ..
SCLCL2525X09-P	9	25	25	110	18,5	0°	0°	G1/8"	

Square shank

Dimensional drawing shows right-hand version. | Measured with master insert: CC .. 09T308 | The maximum recommended coolant pressure is 150 bar (2175 psi) | Refer to the Walter online catalogue for more product information: [www.walter-tools.com](http://www.walter-tools.com) | Bodies and assembly parts are included in the scope of delivery

## Assembly parts

	Type h = h <sub>1</sub> [mm]	CC .. 09T3 .. 20–25
	Clamping screw for indexable insert Tightening torque	FS2060 (T15IP) 3 Nm
	Shim	AP313-CC0908
	Screw for shim	FS2068 (SW 3,5)
	M6 threaded plug	FS2288 (SW 3)
	G 1/8" threaded plug	FS2258 (SW 2)
	Torx key	FS1465 (T15IP)



## Shank tool – Screw clamping

SCLC...-P inch

Walter Turn



– Precision cooling

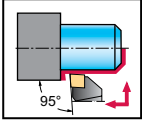

## Tool

Designation		h = h <sub>1</sub> inch	b inch	f inch	l <sub>1</sub> inch	l <sub>4</sub> inch	γ	λ <sub>s</sub>	T <sub>h</sub>	Type
SCLCR123B-P		9	0,750	0,750	1,000	4,500	0°	0°	G1/8"	CC .. 09T3 .. CC .. 3(2.5) ..
SCLCR163D-P		9	1,000	1,000	1,250	6,000	0°	0°	G1/8"	
SCLCL123B-P		9	0,750	0,750	1,000	4,500	0°	0°	G1/8"	CC .. 09T3 .. CC .. 3(2.5) ..
SCLCL163D-P		9	1,000	1,000	1,250	6,000	0°	0°	G1/8"	

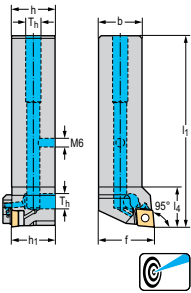

Square shank

Dimensional drawing shows right-hand version. | Measured with master insert: CC .. 09T308 / CC .. 09T304 | The maximum recommended coolant pressure is 150 bar (2175 psi) | Refer to the Walter online catalogue for more product information: [www.walter-tools.com](http://www.walter-tools.com) | Bodies and assembly parts are included in the scope of delivery

## Assembly parts

	Type h = h <sub>1</sub> [inch]	CC .. 09T3 .. 0,75–1
	Clamping screw for indexable insert Tightening torque	FS2060 (T15IP) 2,213 lbs
	Shim	AP313-CC0908
	Screw for shim	FS2068 (SW 3,5)
	M6 threaded plug	FS2288 (SW 3)
	G 1/8" threaded plug	FS2258 (SW 2)
	Torx key	FS1465 (T15IP)

## Shank tool – Screw clamping





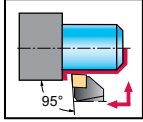
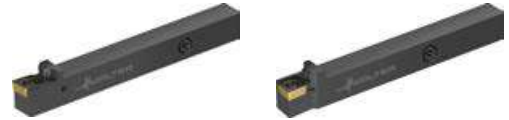

SCLC...-S-P 

## Walter Turn

- Precision cooling
- For Swiss Machining









## Tool

Designation		$h = h_1$ mm	$b$ mm	$f$ mm	$l_1$ mm	$l_4$ mm	$\gamma$	$\lambda_s$	$T_h$	Type
SCLCR1010H06-S-P		6	10	10	100	16	0°	0°	M6	CC .. 0602 ..
SCLCR1212J09-S-P		9	12	12	110	18	0°	0°	M8X1	CC .. 09T3 ..
SCLCR1616X09-S-P		9	16	16	120	18	0°	0°	G1/8"	CC .. 09T3 ..
SCLCL1010H06-S-P		6	10	10	100	16	0°	0°	M6	CC .. 0602 ..
SCLCL1212J09-S-P		9	12	12	110	18	0°	0°	M8X1	CC .. 09T3 ..
SCLCL1616X09-S-P		9	16	16	120	18	0°	0°	G1/8"	CC .. 09T3 ..



Square shank

Dimensional drawing shows right-hand version. | Measured with master insert: CC .. 060204 / CC .. 09T308 | The maximum recommended coolant pressure is 150 bar (2175 psi) | Refer to the Walter online catalogue for more product information: [www.walter-tools.com](http://www.walter-tools.com) | Bodies and assembly parts are included in the scope of delivery

## Assembly parts

Type $h = h_1$ [mm]	CC .. 0602 .. 10	CC .. 09T3 .. 12	CC .. 09T3 .. 16
 Clamping screw for indexable insert Tightening torque	FS2061 (T7IP) 0,9 Nm	FS2119 (T15IP) 3 Nm	FS2119 (T15IP) 3 Nm
 G 1/8" threaded plug			FS2258 (SW 2)
 M8X1 threaded plug		FS2587 (SW 4)	
 Torx key		FS1496 (T15IP)	FS1496 (T15IP)
 M6 threaded plug	FS2288 (SW 3)		
 Torx key	FS1490 (T7IP)		

## Accessories

Type $h = h_1$ [mm]	CC .. 0602 ..-CC .. 09T3 .. 10-16	CC .. 09T3 .. 12
 M8x1 angle connection		FS2596
 M8x1 connection element		FS2597
 Copper gasket		FS2598

# Shank tool – Screw clamping

SDHC

Walter Turn

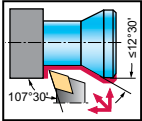

Tool	Designation		h = h <sub>1</sub> mm	b mm	f mm	l <sub>1</sub> mm	l <sub>4</sub> mm	γ	λ <sub>s</sub>	Type
										Type
<p>Square shank</p>	SDHCR1212F07	7	12	12	16	80	14,3	0°	0°	DC .. 0702 ..
	SDHCR1616H11	11	16	16	20	100	17,9	0°	0°	DC .. 11T3 ..
	SDHCR2020K11	11	20	20	25	125	17,9	0°	0°	
	SDHCR2525M11	11	25	25	32	150	20	0°	0°	
	SDHCL1212F07	7	12	12	16	80	14,3	0°	0°	DC .. 0702 ..
	SDHCL1616H11	11	16	16	20	100	17,9	0°	0°	DC .. 11T3 ..
	SDHCL2020K11	11	20	20	20	125	17,9	0°	0°	
	SDHCL2525M11	11	25	25	32	150	19,7	0°	0°	

Dimensional drawing shows right-hand version. | Measured with master insert: DC .. 070204 / DC .. 11T308 | Refer to the Walter online catalogue for more product information: [www.walter-tools.com](http://www.walter-tools.com) | Bodies and assembly parts are included in the scope of delivery

Assembly parts		DC .. 0702 .. 12	DC .. 11T3 .. 16–25
	Clamping screw for indexable insert Tightening torque	FS2061 (T7IP) 0,9 Nm	FS2060 (T15IP) 3 Nm
	Shim		AP315-DC1108
	Screw for shim		FS2068 (SW 3,5)
	Torx key	FS1490 (T7IP)	FS1465 (T15IP)

Accessories		DC .. 0702 ..	DC .. 11T3 ..
	Shim		AP329-DC1112

## Shank tool – Screw clamping

SDJC 

Walter Turn

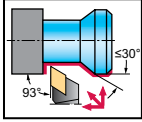

## Tool

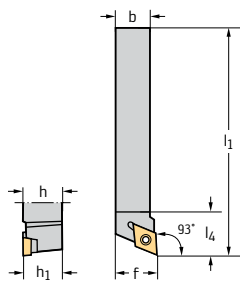

Square shank

Designation		h = h <sub>1</sub> mm	b mm	f mm	l <sub>1</sub> mm	l <sub>4</sub> mm	γ	λ <sub>s</sub>	Type
SDJCR1010E07		7	10	12	70	15,7	0°	0°	DC .. 0702 ..
SDJCR1212F07		7	12	16	80	15,5	0°	0°	
SDJCR1616H11		11	16	20	100	20,3	0°	0°	DC .. 11T3 ..
SDJCR2020K11		11	20	25	125	21,9	0°	0°	
SDJCR2525M11		11	25	32	150	24,4	0°	0°	
SDJCL1010E07		7	10	12	70	15,7	0°	0°	DC .. 0702 ..
SDJCL1212F07		7	12	16	80	15,5	0°	0°	DC .. 11T3 ..
SDJCL1616H11		11	16	20	100	20,3	0°	0°	
SDJCL2020K11		11	20	25	125	21,9	0°	0°	
SDJCL2525M11		11	25	32	150	24,4	0°	0°	

Dimensional drawing shows right-hand version. | Measured with master insert: DC .. 070204 / DC .. 11T308 | Refer to the Walter online catalogue for more product information: [www.walter-tools.com](http://www.walter-tools.com) | Bodies and assembly parts are included in the scope of delivery

## Assembly parts

	Type h = h <sub>1</sub> [mm]	DC .. 0702 .. 10–12	DC .. 11T3 .. 16–25
	Clamping screw for indexable insert Tightening torque	FS2061 (T7IP) 0,9 Nm	FS2060 (T15IP) 3 Nm
	Shim		AP315-DC1108
	Screw for shim		FS2068 (SW 3,5)
	Torx key	FS1490 (T7IP)	FS1465 (T15IP)

## Accessories

	Type	DC .. 0702 ..	DC .. 11T3 ..
	Shim		AP329-DC1112

# Shank tool – Screw clamping

SDJC inch

Walter Turn

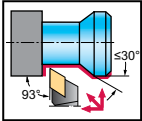

## Tool

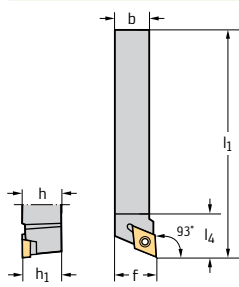

Square shank

Designation		h = h <sub>1</sub> inch	b inch	f inch	l <sub>1</sub> inch	l <sub>4</sub> inch	γ	λ <sub>s</sub>	Type
SDJCR062		7	0,375	0,375	0,500	2,500	0°	0°	DC .. 0702 .. DC .. 2(1.5) ..
SDJCR082		7	0,500	0,500	0,625	3,500	0°	0°	
SDJCR102		7	0,625	0,625	0,750	4,000	0°	0°	DC .. 11T3 .. DC .. 3(2.5) ..
SDJCR123B		11	0,750	0,750	1,000	4,500	0°	0°	
SDJCR163C		11	1,000	1,000	1,250	5,000	0°	0°	DC .. 11T3 .. DC .. 3(2.5) ..
SDJCR163D		11	1,000	1,000	1,250	6,000	0°	0°	
SDJCL062		7	0,375	0,375	0,500	2,500	0°	0°	DC .. 0702 .. DC .. 2(1.5) ..
SDJCL082		7	0,500	0,500	0,625	3,500	0°	0°	
SDJCL102		7	0,625	0,625	0,750	4,000	0°	0°	DC .. 11T3 .. DC .. 3(2.5) ..
SDJCL123B		11	0,750	0,750	1,000	4,500	0°	0°	
SDJCL163C		11	1,000	1,000	1,250	5,000	0°	0°	DC .. 11T3 .. DC .. 3(2.5) ..
SDJCL163D		11	1,000	1,000	1,250	6,000	0°	0°	

Dimensional drawing shows right-hand version. | Measured with master insert: DC .. 070204 / DC .. 11T308 | Refer to the Walter online catalogue for more product information: [www.walter-tools.com](http://www.walter-tools.com) | Bodies and assembly parts are included in the scope of delivery

## Assembly parts

	Type h = h <sub>1</sub> [inch]	DC .. 0702 .. 0,375–0,625	DC .. 11T3 .. 0,75–1
	Clamping screw for indexable insert Tightening torque	FS2061 (T7IP) 0,664 lbs	FS2060 (T15IP) 2,213 lbs
	Shim		AP315-DC1108
	Screw for shim		FS2068 (SW 3,5)
	Torx key	FS1490 (T7IP)	FS1465 (T15IP)

## Accessories

	Type	DC .. 0702 ..	DC .. 11T3 ..
	Shim		AP329-DC1112

## Shank tool – Screw clamping

SDJC...-P 

## Walter Turn

– Precision cooling

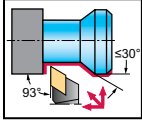

## Tool

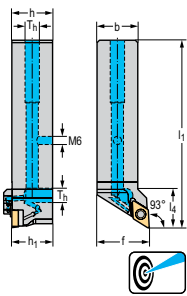

Designation

h = h<sub>1</sub>  
mmb  
mmf  
mml<sub>1</sub>  
mml<sub>4</sub>  
mm

γ

λ<sub>s</sub>T<sub>h</sub>

Type

SDJCR2020X11-P

11

20

20

25

100

23,5

0°

0°

G1/8"

DC .. 11T3 ..

SDJCR2525X11-P

11

25

25

32

115

23,5

0°

0°

G1/8"

SDJCL2020X11-P

11

20

20

25

100

23,5

0°

0°

G1/8"

DC .. 11T3 ..

SDJCL2525X11-P

11

25

25

32

115

23,5

0°

0°

G1/8"

Square shank

Dimensional drawing shows right-hand version. | Measured with master insert: DC .. 11T308 | The maximum recommended coolant pressure is 150 bar (2175 psi) | Refer to the Walter online catalogue for more product information: [www.walter-tools.com](http://www.walter-tools.com) | Bodies and assembly parts are included in the scope of delivery

## Assembly parts

Type  
h = h<sub>1</sub> [mm]DC .. 11T3 ..  
20–25Clamping screw for indexable insert  
Tightening torqueFS2060 (T15IP)  
3 Nm

Shim

AP315-DC1108



Screw for shim

FS2068 (SW 3,5)



M6 threaded plug

FS2288 (SW 3)



G 1/8" threaded plug

FS2258 (SW 2)

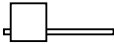

Torx key

FS1465 (T15IP)

# Shank tool – Screw clamping

SDJC...-P inch

**Walter Turn**



– Precision cooling

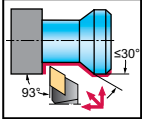

Tool			$h = h_1$ inch	$b$ inch	$f$ inch	$l_1$ inch	$l_2$ inch	$\gamma$	$\lambda_s$	$T_h$	Type
	SDJCR123B-P	11	0,750	0,750	1,000	4,500	0,925	0°	0°	G1/8"	DC .. 11T3 .. DC .. 3(2.5) ..
	SDJCR163D-P	11	1,000	1,000	1,250	6,000	0,925	0°	0°	G1/8"	
	SDJCL123B-P	11	0,750	0,750	1,000	4,500	0,925	0°	0°	G1/8"	DC .. 11T3 .. DC .. 3(2.5) ..
	SDJCL163D-P	11	1,000	1,000	1,250	6,000	0,925	0°	0°	G1/8"	

Square shank

Dimensional drawing shows right-hand version. | Measured with master insert: DC .. 11T308 | The maximum recommended coolant pressure is 150 bar (2175 psi) | Refer to the Walter online catalogue for more product information: [www.walter-tools.com](http://www.walter-tools.com) | Bodies and assembly parts are included in the scope of delivery

Assembly parts		Type $h = h_1$ [inch]	DC .. 11T3 .. 0,75–1
	Clamping screw for indexable insert Tightening torque		FS2060 (T15IP) 2,213 lbs
	Shim		AP315-DC1108
	Screw for shim		FS2068 (SW 3,5)
	M6 threaded plug		FS2288 (SW 3)
	G 1/8" threaded plug		FS2258 (SW 2)
	Torx key		FS1465 (T15IP)

## Shank tool – Screw clamping

SDJC...-S-P 

## Walter Turn

- Precision cooling
- For Swiss Machining

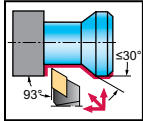

## Tool

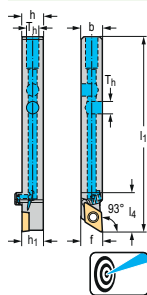

Designation	h = h <sub>1</sub> mm	b mm	f mm	l <sub>1</sub> mm	l <sub>4</sub> mm	γ	λ <sub>s</sub>	T <sub>h</sub>	Type
SDJCR1010H07-S-P	7	10	10	100	17	0°	0°	M6	DC .. 0702 ..
SDJCR1212J07-S-P	7	12	12	110	17	0°	0°	M8X1	
SDJCR1212J11-S-P	11	12	12	110	22	0°	0°	M8X1	DC .. 11T3 ..
SDJCR1616X11-S-P	11	16	16	120	22	0°	0°	G1/8"	
SDJCL1010H07-S-P	7	10	10	100	17	0°	0°	M6	DC .. 0702 ..
SDJCL1212J07-S-P	7	12	12	110	17	0°	0°	M8X1	
SDJCL1212J11-S-P	11	12	12	110	22	0°	0°	M8X1	DC .. 11T3 ..
SDJCL1616X11-S-P	11	16	16	120	22	0°	0°	G1/8"	

Square shank

Dimensional drawing shows right-hand version. | Measured with master insert: DC .. 070204 / DC .. 11T308 | The maximum recommended coolant pressure is 150 bar (2175 psi) | Refer to the Walter online catalogue for more product information: [www.walter-tools.com](http://www.walter-tools.com) | Bodies and assembly parts are included in the scope of delivery

## Assembly parts

Type h = h <sub>1</sub> [mm]	DC .. 0702 .. 10	DC .. 0702 .. 12	DC .. 11T3 .. 12	DC .. 11T3 .. 16
Clamping screw for indexable insert Tightening torque	FS2061 (T7IP) 0,9 Nm	FS2061 (T7IP) 0,9 Nm	FS2119 (T15IP) 3 Nm	FS2119 (T15IP) 3 Nm
G 1/8" threaded plug				FS2258 (SW 2)
Torx key			FS1496 (T15IP)	FS1496 (T15IP)
M6 threaded plug	FS2288 (SW 3)			
M8X1 threaded plug		FS2587 (SW 4)	FS2587 (SW 4)	
Torx key	FS1490 (T7IP)	FS1490 (T7IP)		

## Accessories

Type h = h <sub>1</sub> [mm]	DC .. 0702 ..–DC .. 11T3 .. 10–16	DC .. 11T3 .. 12
M8x1 angle connection		FS2596
M8x1 connection element		FS2597
Copper gasket		FS2598



## Shank tool – Rigid clamping

DDJC...-P 

Walter Turn



– Precision cooling

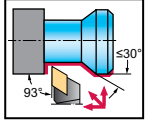

## Tool

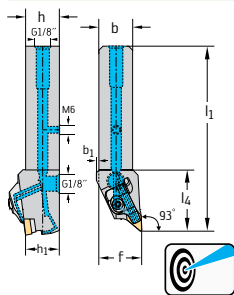

Designation		h = h <sub>1</sub> mm	b mm	b <sub>1</sub> mm	f mm	l <sub>1</sub> mm	l <sub>4</sub> mm	γ	λ <sub>s</sub>	Type	
DDJCR2020X11-P		11	20	20	6	25	125	48,5	-3°	-7°	DC .. 11T3 ..
DDJCR2525X11-P		11	25	25	0	32	140	48,5	-3°	-7°	
DDJCL2020X11-P		11	20	20	6	25	125	48,5	-3°	-7°	DC .. 11T3 ..
DDJCL2525X11-P		11	25	25	0	32	140	48,5	-3°	-7°	

Square shank

Dimensional drawing shows right-hand version. | Measured with master insert: DC .. 11T308 | For the connection set for internal coolant supply with G1/8" thread, see „Assembly parts and accessories“ | The maximum recommended coolant pressure is 150 bar (2175 psi) | Refer to the Walter online catalogue for more product information: [www.walter-tools.com](http://www.walter-tools.com) | Bodies and assembly parts are included in the scope of delivery

## Assembly parts

	Type h = h <sub>1</sub> [mm]	DC .. 11T3 .. 20–25
	Shim	AP315-DC1108
	Screw for shim	FS2068 (SW 3,5)
	Right clamp	PK261R
	Left clamp	PK261L
	Screw for clamp Tightening torque	FS1473 (T15IP) 3,9 Nm
	Pressure spring	FS2188
	G 1/8" threaded plug	FS2258 (SW 2)
	M6 threaded plug	FS2288 (SW 3)
	Torx key	FS1465 (T15IP)

## Accessories

	Type	DC .. 11T3 ..
	(standard assembly parts) Right clamp set	PK261R-SET
	(standard assembly parts) Left clamp set	PK261L-SET

## Shank tool – Screw clamping

SDNC 

Walter Turn

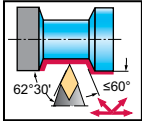

## Tool

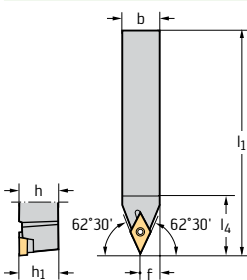

Designation

 $h = h_1$   
mmb  
mmf  
mm $l_1$   
mm $l_4$   
mm $\gamma$  $\lambda_s$ 

Type

SDNCN1010E07	7	10	10	5,2	70	14,5	0°	0°	DC .. 0702 ..
SDNCN1212F07	7	12	12	6,2	80	14,5	0°	0°	
SDNCN1616H11	11	16	16	8,5	100	21,9	0°	0°	DC .. 11T3 ..
SDNCN2020K11	11	20	20	10,5	125	21,9	0°	0°	
SDNCN2525M11	11	25	25	13	150	22,2	0°	0°	

Square shank

Measured with master insert: DC .. 070204 / DC .. 11T308 | Refer to the Walter online catalogue for more product information: [www.walter-tools.com](http://www.walter-tools.com) | Bodies and assembly parts are included in the scope of delivery

## Assembly parts



Type

 $h = h_1$  [mm]

DC .. 0702 ..

10–12

DC .. 11T3 ..

16–25

Clamping screw for indexable insert  
Tightening torqueFS2061 (T7IP)  
0,9 NmFS2060 (T15IP)  
3 Nm

Shim

AP315-DC1108



Screw for shim

FS2068 (SW 3,5)



Torx key

FS1490 (T7IP)

FS1465 (T15IP)

## Accessories



Type

Shim

DC .. 0702 ..

DC .. 11T3 ..

AP329-DC1112

## Shank tool – Screw clamping

SDNC...-P 

## Walter Turn

- Precision cooling
- For Swiss Machining

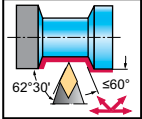

## Tool

Designation												
	$h = h_1$ mm	$h_4$ mm	$b$ mm	$f$ mm	$l_1$ mm	$l_4$ mm	$\gamma$	$\lambda_s$	$T_h$	Type		
SDNCN1212J07-P	7	12	4	12	6	110	18	0°	0°	M8X1	DC .. 0702 ..	
SDNCN1212J11-P	11	12	4	12	6	110	24	0°	0°	M8X1	DC .. 11T3 ..	
SDNCN1616X11-P	11	16	4	16	8	120	24	0°	0°	G1/8"		

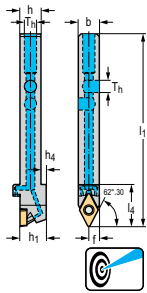

Square shank

Measured with master insert: DC .. 070204 / DC .. 11T308 | The maximum recommended coolant pressure is 150 bar (2175 psi) | Refer to the Walter online catalogue for more product information: [www.walter-tools.com](http://www.walter-tools.com) | Bodies and assembly parts are included in the scope of delivery

## Assembly parts

Type $h = h_1$ (mm)	DC .. 0702 .. 12	DC .. 11T3 .. 12	DC .. 11T3 .. 16
 Clamping screw for indexable insert Tightening torque	FS2061 (T7IP) 0,9 Nm	FS2119 (T15IP) 3 Nm	FS2119 (T15IP) 3 Nm
 G 1/8" threaded plug			FS2258 (SW 2)
 M8X1 threaded plug	FS2587 (SW 4)	FS2587 (SW 4)	
 Torx key	FS1490 (T7IP)	FS1465 (T15IP)	FS1465 (T15IP)

## Shank tool – Screw clamping

SRAC inch

Walter Turn

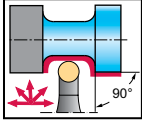

## Tool

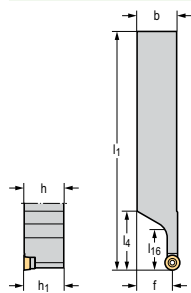

Square shank

Designation		h = h <sub>1</sub> inch	b inch	f inch	h <sub>1</sub> inch	l <sub>4</sub> inch	h <sub>16</sub> inch	γ	λ <sub>s</sub>	Type
SRACR162D	6	1,000	1,000	1,075	6,000	1,548	1,000	0°	0°	RC .. 0603 .. RC .. 22 ..
SRACR163D	9	1,000	1,000	1,075	6,000	1,548	1,000	0°	0°	RC .. 09T3 .. RC .. 3(2.5) ..
SRACR164D	12	1,000	1,000	1,075	6,000	1,548	1,000	0°	0°	RC .. 1204 .. RC .. 43 ..
SRACR204D	12	1,250	1,250	1,075	6,000	1,548	1,000	0°	0°	
SRACL162D	6	1,000	1,000	1,075	6,000	1,548	1,000	0°	0°	RC .. 0603 .. RC .. 22 ..
SRACL163D	9	1,000	1,000	1,075	6,000	1,548	1,000	0°	0°	RC .. 09T3 .. RC .. 3(2.5) ..
SRACL164D	12	1,000	1,000	1,075	6,000	1,548	1,000	0°	0°	RC .. 1204 .. RC .. 43 ..
SRACL204D	12	1,250	1,250	1,075	6,000	1,548	1,000	0°	0°	

Dimensional drawing shows right-hand version. | Measured with master insert: RC .. 060300 / RC .. 09T300 / RC .. 120400 | Refer to the Walter online catalogue for more product information: [www.walter-tools.com](http://www.walter-tools.com) | Bodies and assembly parts are included in the scope of delivery

## Assembly parts

	Type h = h <sub>1</sub> [inch]	RC .. 0603 .. 1	RC .. 09T3 .. 1	RC .. 1204 .. 1-1,25
	Clamping screw for indexable insert Tightening torque	FS2061 (T7IP) 0,664 lbs	FS2116 (T9IP) 1,106 lbs	FS2117 (T15IP) 2,213 lbs
	Shim		AP190-RC09T3	AP189-RC1204
	Torx key	FS1490 (T7IP)	FS1466 (T9IP)	FS1465 (T15IP)

## Shank tool – Screw clamping

SRDC 

Walter Turn

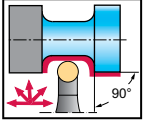

## Tool

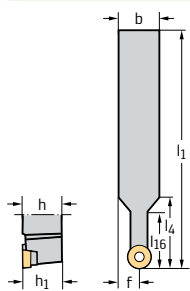

Square shank

Designation		h = h <sub>1</sub> mm	b mm	f mm	l <sub>1</sub> mm	l <sub>4</sub> mm	l <sub>16</sub> mm	γ	λ <sub>s</sub>	Type
SRDCN1212F06	6	12	12	6	80	17	12	0°	0°	RC .. T0602M0 ..
SRDCN2020K06	6	20	20	10	125	32	24	0°	0°	
SRDCN2525M06	6	25	25	12,5	150	54	25	0°	0°	
SRDCN1616H08	8	16	16	8	100	21,5	16	0°	0°	RC .. T0803M0 ..
SRDCN2020K08	8	20	20	10	125	32	24	0°	0°	
SRDCN2525M08	8	25	25	12,5	150	33	25	0°	0°	
SRDCN2020K10	10	20	20	10	125	31	25	0°	0°	RC .. T10T3M0 ..
SRDCN2525M10	10	25	25	12,5	150	32	25	0°	0°	
SRDCN2020K12	12	20	20	10	125	31	25	0°	0°	RC .. T1204M0 ..
SRDCN2525M12	12	25	25	12,5	150	35	28	0°	0°	
SRDCN3225P12	12	32	25	12,5	170	35	28	0°	0°	
SRDCN3225P16	16	32	25	12,5	170	40	35	0°	0°	RC .. T1606M0 ..

Measured with master insert: RC .. 0602M0 / RC .. 0803M0 / RC .. 10T3M0 / RC .. 1204M0 / RC .. 1606M0 | Refer to the Walter online catalogue for more product information: [www.walter-tools.com](http://www.walter-tools.com) | Bodies and assembly parts are included in the scope of delivery

## Assembly parts

Type h = h <sub>1</sub> [mm]	RC .. T0602M0 .. 12–25	RC .. T0803M0 .. 16–25	RC .. T10T3M0 .. 20–25	RC .. T1204M0 .. 20–32	RC .. T1606M0 .. 32
Clamping screw for indexable insert Tightening torque	FS2061 (T7IP) 0,9 Nm	FS1462 (T9IP) 1,5 Nm	FS2063 (T15IP) 3 Nm	FS2060 (T15IP) 3 Nm	FS2090 (T20IP) 6,4 Nm
Shim			AP324-RC10T3	AP325-RC1204	AP326-RC1606
Screw for shim			FS2068 (SW 3,5)	FS2068 (SW 3,5)	FS2091 (SW 5)
Torx key	FS1490 (T7IP)	FS1466 (T9IP)	FS1465 (T15IP)	FS1465 (T15IP)	
Allen key					FS1464 (T20IP)

## Shank tool – Screw clamping

SRDC inch

Walter Turn

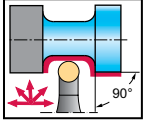

## Tool

Designation		h = h <sub>1</sub> inch	b inch	f inch	l <sub>1</sub> inch	l <sub>4</sub> inch	l <sub>16</sub> inch	γ	λ <sub>s</sub>	Type
SRDCN082	6	0,500	0,500	0,246	3,500	0,500	0,701	0°	0°	RC .. 0603 .. RC .. 22 ..
SRDCN103	9	0,625	0,625	0,312	4,000	0,625	0,774	0°	0°	RC .. 09T3 .. RC .. 3(2.5) ..
SRDCN123B	9	0,750	0,750	0,375	4,500	0,935	0,750	0°	0°	
SRDCN163D	9	1,000	1,000	0,500	6,000	1,257	1,000	0°	0°	RC .. 1204 .. RC .. 43 ..
SRDCN164D	12	1,000	1,000	0,500	6,000	1,257	1,000	0°	0°	
SRDCN204D	12	1,250	1,250	0,625	6,000	1,287	1,000	0°	0°	

Square shank

Measured with master insert: RC .. 060300 / RC .. 09T300 / RC .. 120400 | Refer to the Walter online catalogue for more product information: [www.walter-tools.com](http://www.walter-tools.com) | Bodies and assembly parts are included in the scope of delivery

## Assembly parts

Type h = h <sub>1</sub> [inch]	RC .. 0603 .. 0,5	RC .. 09T3 .. 0,625-1	RC .. 1204 .. 1-1,25
Clamping screw for indexable insert Tightening torque	FS2061 (T7IP) 0,664 lbs	FS2116 (T9IP) 1,106 lbs	FS2117 (T15IP) 2,213 lbs
Shim		AP190-RC09T3	AP189-RC1204
Torx key	FS1490 (T7IP)	FS1466 (T9IP)	FS1465 (T15IP)

## Shank tool – Lever clamping

PRDC 

Walter Turn

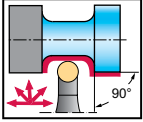

Tool	Designation		h = h <sub>1</sub> mm	b mm	f mm	l <sub>1</sub> mm	l <sub>4</sub> mm	l <sub>6</sub> mm	γ	λ <sub>s</sub>	Type
	PRDCN2020K10		10	20	10	125	30	25	0°	0°	RC .. T10T3M0 ..
	PRDCN2525M10		10	25	12,5	150	32	25	0°	0°	RC .. T1204M0 ..
	PRDCN2525M12		12	25	12,5	150	33	28	0°	0°	RC .. T1605M0 ..
	PRDCN3225P12		12	32	12,5	170	33	28	0°	0°	RC .. T2006M0 ..
	PRDCN3225P16		16	32	12,5	170	40	35	0°	0°	RC .. T2507M0 ..
	PRDCN3232P20		20	32	16	170	45	40	0°	0°	RC .. 3209 ..
	PRDCN4040S25		25	40	20	250	55	50	0°	0°	
	PRDCN5050U32		32	50	25	350	60	55	0°	0°	

Square shank

Measured with master insert: RC .. 10T3M0 / RC .. 1204M0 / RC .. 1605M0 / RC .. 2006M0 / RC .. 2507M0 / RC .. 3209M0 | Refer to the Walter online catalogue for more product information: [www.walter-tools.com](http://www.walter-tools.com) | Bodies and assembly parts are included in the scope of delivery

Assembly parts		Type h = h <sub>1</sub> (mm)	RC .. T10T3M0 .. 20–25	RC .. T1204M0 .. 25–32	RC .. T1605M0 .. 32	RC .. T2006M0 .. 32	RC .. T2507M0 .. 40	RC .. 3209 .. 50
	Shim		AP407-RC10T3	AP402-RC1204	AP403-RC1606	AP404-RC2006	AP405-RC2507	AP406-RC3209
	Lever		KN122	KN123	KN111	KN112	KN113	KN124
	Clamping screw Tightening torque		FS2155 (SW 2) 0,6 Nm	FS351 (SW 2,5) 2 Nm	FS344 (SW 2,5) 2,5 Nm	FS2156 (SW 3) 5 Nm	FS2145 (SW 4) 10 Nm	FS357 (SW 5) 14 Nm
	Shim pin		RS101	RS120	RS118	RS103	RS104	RS105
	Tapered assembly pin		MD101	MD101	MD101	MD102	MD102	MD103
	Allen key		ISO2936-2 (SW 2)	ISO2936-2,5 (SW 2,5)	ISO2936-2,5 (SW 2,5)	ISO2936-3 (SW 3)	ISO2936-4 (SW 4)	ISO2936-5 (SW 5)

Accessories		Type	RC .. T10T3M0 ..	RC .. T1204M0 ..–RC .. 3209 ..	RC .. T1605M0 ..
	Shim for RC .. 1003 ..		AP401-RC1003		
	Shim for RC .. 1605 ..				AP403-RC1605

## Shank tool – Screw clamping

SRSC 

Walter Turn

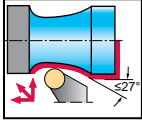

## Tool

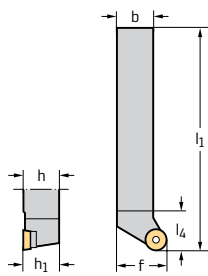

Square shank

Designation		$h = h_1$ mm	b mm	f mm	$l_1$ mm	$l_4$ mm	$\gamma$	$\lambda_s$	Type
SRSCR2020K06	6	20	20	25	125	20	0°	0°	RC .. T0602M0 ..
SRSCR2525M06	6	25	25	32	150	20	0°	0°	
SRSCR2020K08	8	20	20	25	125	20	0°	0°	RC .. T0803M0 ..
SRSCR2525M08	8	25	25	32	150	20	0°	0°	
SRSCR2020K10	10	20	20	25	125	20	0°	0°	RC .. T10T3M0 ..
SRSCR2525M10	10	25	25	32	150	28	0°	0°	
SRSCR2020K12	12	20	20	25	125	22	0°	0°	RC .. T1204M0 ..
SRSCR2525M12	12	25	25	32	150	28	0°	0°	
SRSCR3225P12	12	32	25	32	170	32	0°	0°	
SRSCR3225P16	16	32	25	32	170	32	0°	0°	RC .. T1606M0 ..
SRSCL2020K06	6	20	20	25	125	20	0°	0°	RC .. T0602M0 ..
SRSCL2525M06	6	25	25	32	150	20	0°	0°	
SRSCL2020K08	8	20	20	25	125	20	0°	0°	RC .. T0803M0 ..
SRSCL2525M08	8	25	25	32	150	20	0°	0°	
SRSCL2020K10	10	20	20	25	125	20	0°	0°	RC .. T10T3M0 ..
SRSCL2525M10	10	25	25	32	150	28	0°	0°	
SRSCL2020K12	12	20	20	25	125	22	0°	0°	RC .. T1204M0 ..
SRSCL2525M12	12	25	25	32	150	28	0°	0°	
SRSCL3225P12	12	32	25	32	170	32	0°	0°	
SRSCL3225P16	16	32	25	32	170	32	0°	0°	RC .. T1606M0 ..

Dimensional drawing shows right-hand version. | Measured with master insert: RC .. 0602M0 / RC .. 0803M0 / RC .. 10T3M0 / RC .. 1204M0 / RC .. 1606M0 | Refer to the Walter online catalogue for more product information: [www.walter-tools.com](http://www.walter-tools.com) | Bodies and assembly parts are included in the scope of delivery

## Assembly parts

Type h = h <sub>1</sub> [mm]	RC .. T0602M0 .. 20–25	RC .. T0803M0 .. 20–25	RC .. T10T3M0 .. 20–25	RC .. T1204M0 .. 20–32	RC .. T1606M0 .. 32
Clamping screw for indexable insert Tightening torque	FS2061 (T7IP) 0,9 Nm	FS1462 (T9IP) 1,5 Nm	FS2063 (T15IP) 3 Nm	FS2060 (T15IP) 3 Nm	FS2090 (T20IP) 6,4 Nm
Shim			AP324-RC10T3	AP325-RC1204	AP326-RC1606
Screw for shim			FS2068 (SW 3,5)	FS2068 (SW 3,5)	FS2091 (SW 5)
Torx key	FS1490 (T7IP)	FS1466 (T9IP)	FS1465 (T15IP)	FS1465 (T15IP)	
Allen key					FS1464 (T20IP)



# Shank tool – Screw clamping

SRSC inch

Walter Turn

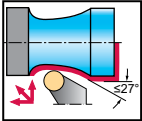

Tool			$h = h_1$ inch	b inch	f inch	$l_1$ inch	$l_4$ inch	$\gamma$	$\lambda_s$	Type
<p>Square shank</p>	SRSCR162D	6	1,000	1,000	1,250	6,000	1,113	0°	0°	RC .. 0603 .. RC .. 22 ..
	SRSCR163D	9	1,000	1,000	1,250	6,000	1,331	0°	0°	RC .. 09T3 .. RC .. 3(2.5) ..
	SRSCR164D	12	1,000	1,000	1,250	6,000	1,446	0°	0°	RC .. 1204 .. RC .. 43 ..
	SRSCL162D	6	1,000	1,000	1,250	6,000	1,113	0°	0°	RC .. 0603 .. RC .. 22 ..
	SRSCL163D	9	1,000	1,000	1,250	6,000	1,331	0°	0°	RC .. 09T3 .. RC .. 3(2.5) ..
	SRSCL164D	12	1,000	1,000	1,250	6,000	1,446	0°	0°	RC .. 1204 .. RC .. 43 ..

Dimensional drawing shows right-hand version. | Measured with master insert: RC .. 060300 / RC .. 09T300 / RC .. 120400 | Refer to the Walter online catalogue for more product information: [www.walter-tools.com](http://www.walter-tools.com) | Bodies and assembly parts are included in the scope of delivery

Assembly parts		Type $h = h_1$ (inch)	RC .. 0603 .. 1	RC .. 09T3 .. 1	RC .. 1204 .. 1
	Clamping screw for indexable insert Tightening torque		FS2061 (T7IP) 0,664 lbs	FS2116 (T9IP) 1,106 lbs	FS2117 (T15IP) 2,213 lbs
	Shim			AP190-RC09T3	AP189-RC1204
	Torx key		FS1490 (T7IP)	FS1466 (T9IP)	FS1465 (T15IP)

## Shank tool – Screw clamping

SRGC inch

Walter Turn

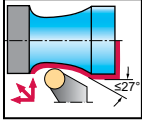

## Tool

Designation		h = h <sub>1</sub> inch	b inch	f inch	l <sub>1</sub> inch	l <sub>4</sub> inch	γ	λ <sub>s</sub>	Type
SRGCR164C	12	1,000	1,000	1,250	5,000	1,331	0°	0°	RC .. 1204 .. RC .. 43 ..
SRGCL164C	12	1,000	1,000	1,250	5,000	1,331	0°	0°	RC .. 1204 .. RC .. 43 ..

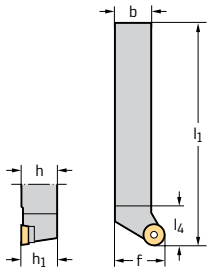

Square shank

Dimensional drawing shows right-hand version. | Measured with master insert: RC .. 120400 | Refer to the Walter online catalogue for more product information: [www.walter-tools.com](http://www.walter-tools.com) | Bodies and assembly parts are included in the scope of delivery

## Assembly parts

	Type h = h <sub>1</sub> [inch]	RC .. 1204 .. 1
	Clamping screw for indexable insert Tightening torque	FS2117 (T15IP) 2,213 lbs
	Shim	AP189-RC1204
	Torx key	FS1465 (T15IP)

## Shank tool – Lever clamping

PRGC 

Walter Turn

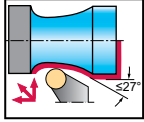

## Tool

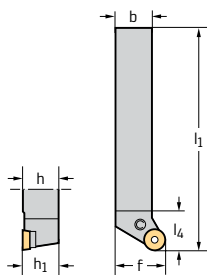







Square shank



Designation		h = h <sub>1</sub> mm	b mm	f mm	l <sub>1</sub> mm	l <sub>4</sub> mm	γ	λ <sub>s</sub>	Type
PRGCR2525M10	10	25	25	32	150	27,2	0°	0°	RC .. T10T3M0 ..
PRGCR2525M12	12	25	25	32	150	27,2	0°	0°	RC .. T1204M0 ..
PRGCR3225P12	12	32	25	32	170	32	0°	0°	
PRGCR3225P16	16	32	25	32	170	33,2	0°	0°	RC .. T1605M0 ..
PRGCR3232P20	20	32	32	40	170	38	0°	0°	RC .. T2006M0 ..
PRGCR4040S25	25	40	40	50	250	50,5	0°	0°	RC .. T2507M0 ..
PRGCL2020K10	10	20	20	25	125	20,8	0°	0°	RC .. T10T3M0 ..
PRGCL2525M10	10	25	25	32	150	27,2	0°	0°	
PRGCL2525M12	12	25	25	32	150	27,2	0°	0°	RC .. T1204M0 ..
PRGCL3225P12	12	32	25	32	170	32	0°	0°	
PRGCL3225P16	16	32	25	32	170	33,2	0°	0°	RC .. T1605M0 ..
PRGCL3232P20	20	32	32	40	170	38	0°	0°	RC .. T2006M0 ..
PRGCL4040S25	25	40	40	50	250	50,5	0°	0°	RC .. T2507M0 ..

Dimensional drawing shows right-hand version. | Measured with master insert: RC .. T10T3M0 / RC .. T1204M0 / RC .. T1605M0 / RC .. T2006M0 / RC .. T2507M0 | Refer to the Walter online catalogue for more product information: [www.walter-tools.com](http://www.walter-tools.com) | Bodies and assembly parts are included in the scope of delivery

## Assembly parts

Type h = h <sub>1</sub> [mm]	RC .. T10T3M0 .. 20–25	RC .. T1204M0 .. 25–32	RC .. T1605M0 .. 32	RC .. T2006M0 .. 32	RC .. T2507M0 .. 40
 Shim	AP407-RC10T3	AP402-RC1204	AP403-RC1606	AP404-RC2006	AP405-RC2507
 Lever	KN122	KN123	KN111	KN112	KN113
 Clamping screw Tightening torque	FS2155 (SW 2) 0,6 Nm	FS351 (SW 2,5) 2 Nm	FS344 (SW 2,5) 2,5 Nm	FS2156 (SW 3) 5 Nm	FS2145 (SW 4) 10 Nm
 Shim pin	RS101	RS120	RS118	RS103	RS104
 Tapered assembly pin	MD101	MD101	MD101	MD102	MD102
 Allen key	ISO2936-2 (SW 2)	ISO2936-2,5 (SW 2,5)	ISO2936-2,5 (SW 2,5)	ISO2936-3 (SW 3)	ISO2936-4 (SW 4)

## Accessories

Type	RC .. T10T3M0 ..	RC .. T1204M0 ..–RC .. T2507M0 ..	RC .. T1605M0 ..
 Shim for RC .. 1003 ..	AP401-RC1003		
 Shim for RC .. 1605 ..			AP403-RC1605

## Shank tool – Screw clamping

SSDC 

Walter Turn

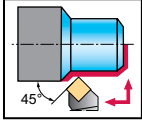

## Tool

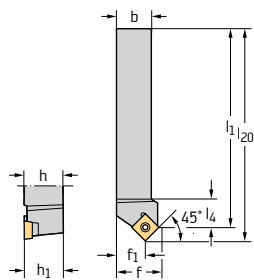

Designation		h = h <sub>1</sub> mm	b mm	f mm	h <sub>1</sub> mm	l <sub>4</sub> mm	l <sub>20</sub> mm	γ	λ <sub>s</sub>	Type
SSDCR1616H09		9	16	10,9	100	9,1	100	0°	0°	SC .. 09T3 ..
SSDCR2020K09		9	20	15,9	125	12	125	0°	0°	SC .. 1204 ..
SSDCR2020K12		12	20	13,7	125	13,7	125	0°	0°	
SSDCR2525M12		12	25	18,7	150	13,7	150	0°	0°	SC .. 09T3 ..
SSDCL1616H09		9	16	10,9	100	9,1	100	0°	0°	
SSDCL2020K09		9	20	15,9	125	12	125	0°	0°	SC .. 1204 ..
SSDCL2020K12		12	20	13,7	125	13,7	125	0°	0°	
SSDCL2525M12		12	25	18,7	150	13,7	150	0°	0°	

Square shank

Dimensional drawing shows right-hand version. | Measured with master insert: SC .. 09T308 / SC .. 120408 | Refer to the Walter online catalogue for more product information: [www.walter-tools.com](http://www.walter-tools.com) | Bodies and assembly parts are included in the scope of delivery

## Assembly parts

Type	h = h <sub>1</sub> [mm]	SC .. 09T3 .. 16–20	SC .. 1204 .. 20–25
Clamping screw for indexable insert Tightening torque		FS2060 (T15IP) 3 Nm	FS2065 (T15IP) 3 Nm
Shim		AP328-SC0908	AP319-SC1212
Screw for shim		FS2068 (SW 3,5)	FS2069 (SW 4)
Torx key		FS1465 (T15IP)	FS1496 (T15IP)

# Shank tool – Screw clamping

SSDCN inch

Walter Turn

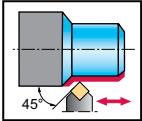

## Tool

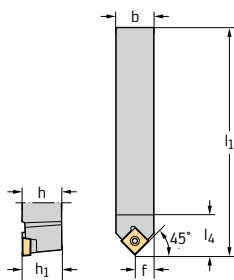

Square shank

Designation		h = h <sub>1</sub> inch	b inch	f inch	l <sub>1</sub> inch	l <sub>4</sub> inch	γ	λ <sub>s</sub>	Type
SSDCN062	6	0,375	0,375	0,191	3,000	0,512	0°	0°	SC .. 0602 .. SC .. 2(1.5) ..
SSDCN082B	6	0,500	0,500	0,254	0,563	0,512	0°	0°	
SSDCN083	9	0,500	0,500	0,261	3,500	0,594	0°	0°	SC .. 09T3 .. SC .. 3(2.5) ..
SSDCN103	9	0,625	0,625	0,323	4,000	0,594	0°	0°	
SSDCN123B	9	0,750	0,750	0,385	4,500	0,594	0°	0°	

Measured with master insert: SC .. 09T308 | Refer to the Walter online catalogue for more product information: [www.walter-tools.com](http://www.walter-tools.com) | Bodies and assembly parts are included in the scope of delivery

## Assembly parts

Type	h = h <sub>1</sub> [inch]	SC .. 0602 .. 0,375–0,5	SC .. 09T3 .. 0,5–0,75
Clamping screw for indexable insert Tightening torque		FS2061 (T7IP) 0,664 lbs	FS2060 (T15IP) 2,213 lbs
Shim			AP328-SC0908
Screw for shim			FS2068 (SW 3,5)
Torx key		FS1490 (T7IP)	FS1465 (T15IP)

## Shank tool – Screw clamping

SSDCN 

Walter Turn

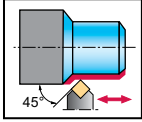

## Tool

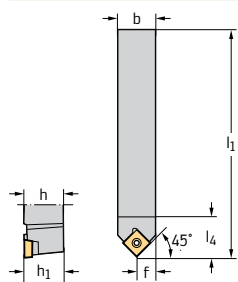

Square shank

Designation

h = h<sub>1</sub>  
mmb  
mmf  
mml<sub>1</sub>  
mml<sub>4</sub>  
mm

γ

λ<sub>s</sub>

Type

SSDCN1212F09

9

12

12

6

80

15,1

0°

0°

SC .. 09T3 ..

SSDCN1616H09

9

16

16

8

100

15,1

0°

0°

SC .. 1204 ..

SSDCN2020K12

12

20

20

10

125

22

0°

0°

SC .. 1204 ..

SSDCN2525M12

12

25

25

12,5

150

22

0°

0°

SC .. 1204 ..

Measured with master insert: SC .. 09T308 / SC .. 120408 | Refer to the Walter online catalogue for more product information: [www.walter-tools.com](http://www.walter-tools.com) | Bodies and assembly parts are included in the scope of delivery

## Assembly parts

Type  
h = h<sub>1</sub> [mm]SC .. 09T3 ..  
12SC .. 09T3 ..  
16SC .. 1204 ..  
20–25Clamping screw for indexable insert  
Tightening torqueFS2063 (T15IP)  
3 NmFS2060 (T15IP)  
3 NmFS2065 (T15IP)  
3 Nm

Shim

AP328-SC0908

AP319-SC1212



Screw for shim

FS2068 (SW 3,5)

FS2069 (SW 4)

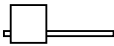

Torx key

FS1465 (T15IP)

FS1465 (T15IP)

FS1496 (T15IP)

# Shank tool – Screw clamping

STGC

Walter Turn

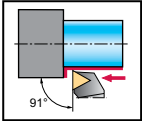

Tool	Designation		h = h <sub>1</sub> mm	b mm	f mm	l <sub>1</sub> mm	l <sub>4</sub> mm	γ	λ <sub>s</sub>	Type
<p>Square shank</p>	STGCR1212F11	11	12	12	16	80	14,1	0°	0°	TC .. 1102 ..
	STGCR1616H16	16	16	16	20	100	20,1	0°	0°	TC .. 16T3 ..
	STGCR2020K16	16	20	20	25	125	20,4	0°	0°	
	STGCR2525M16	16	25	25	32	150	20,9	0°	0°	
	STGCL1212F11	11	12	12	16	80	14,1	0°	0°	TC .. 1102 ..
	STGCL1616H16	16	16	16	20	100	20,1	0°	0°	TC .. 16T3 ..
	STGCL2020K16	16	20	20	25	125	20,4	0°	0°	
	STGCL2525M16	16	25	25	32	150	20,9	0°	0°	

Dimensional drawing shows right-hand version. | Measured with master insert:TC .. 110204 / TC .. 16T308 | Refer to the Walter online catalogue for more product information: [www.walter-tools.com](http://www.walter-tools.com) | Bodies and assembly parts are included in the scope of delivery

Assembly parts	Type h = h <sub>1</sub> [mm]	TC .. 1102 .. 12	TC .. 16T3 .. 16-25
	Clamping screw for indexable insert Tightening torque	FS2061 (T7IP) 0,9 Nm	FS2060 (T15IP) 3 Nm
	Shim		AP317-TC1612
	Screw for shim		FS2068 (SW 3,5)
	Torx key	FS1490 (T7IP)	FS1465 (T15IP)

## Shank tool – Screw clamping

STGC inch

Walter Turn

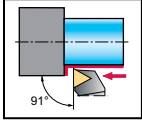

## Tool

Designation		h = h <sub>1</sub> inch	b inch	f inch	l <sub>1</sub> inch	l <sub>4</sub> inch	γ	λ <sub>s</sub>	Type
STGCR062	11	0,375	0,375	0,500	2,500	0,543	0°	0°	TC .. 1102 .. TC .. 2(1.5) ..
STGCR082B	11	0,500	0,500	0,625	3,500	0,598	0°	0°	
STGCR103	16	0,625	0,625	0,750	4,000	0,823	0°	0°	TC .. 16T3 .. TC .. 3(2.5) ..
STGCR123B	16	0,750	0,750	1,000	4,500	0,815	0°	0°	
STGCR163D	16	1,000	1,000	1,250	6,000	0,815	0°	0°	
STGCL062	11	0,375	0,375	0,500	2,500	0,543	0°	0°	TC .. 1102 .. TC .. 2(1.5) ..
STGCL082B	11	0,500	0,500	0,625	3,500	0,598	0°	0°	
STGCL103	16	0,625	0,625	0,750	4,000	0,823	0°	0°	TC .. 16T3 .. TC .. 3(2.5) ..
STGCL123B	16	0,750	0,750	1,000	4,500	0,815	0°	0°	
STGCL163D	16	1,000	1,000	1,250	6,000	0,815	0°	0°	

Dimensional drawing shows right-hand version. | Measured with master insert: TC .. 110204 / TC .. 16T308 | Refer to the Walter online catalogue for more product information: [www.walter-tools.com](http://www.walter-tools.com) | Bodies and assembly parts are included in the scope of delivery

## Assembly parts

	Type h = h <sub>1</sub> [inch]	TC .. 1102 .. 0,375–0,5	TC .. 16T3 .. 0,625–1
	Clamping screw for indexable insert Tightening torque	FS2061 (T7IP) 0,664 lbs	FS2060 (T15IP) 2,213 lbs
	Shim		AP317-TC1612
	Screw for shim		FS2068 (SW 3,5)
	Torx key	FS1490 (T7IP)	FS1465 (T15IP)



# Shank tool – Screw clamping

SVHB

Walter Turn

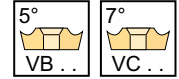
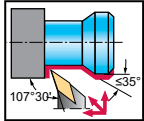

## Tool

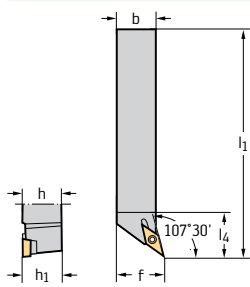

Square shank

Designation		h = h <sub>1</sub> mm	b mm	f mm	l <sub>1</sub> mm	l <sub>4</sub> mm	γ	λ <sub>s</sub>	Type
SVHBR1616H11		11	16	20	100	18	0°	0°	VB .. 1103 ..
SVHBR2020K11		11	20	25	125	19	0°	0°	
SVHBR2525M11		11	25	32	150	27	0°	0°	
SVHBR2020K16		16	20	25	125	27,6	0°	0°	VB .. 1604 ..
SVHBR2525M16		16	25	32	150	27,6	0°	0°	
SVHBR3225P16		16	32	32	170	27,6	0°	0°	
SVHBL1616H11		11	16	20	100	18	0°	0°	VB .. 1103 ..
SVHBL2020K11		11	20	25	125	19	0°	0°	
SVHBL2525M11		11	25	32	150	27	0°	0°	
SVHBL2020K16		16	20	25	125	27,6	0°	0°	VB .. 1604 ..
SVHBL2525M16		16	25	32	150	27,6	0°	0°	
SVHBL3225P16		16	32	32	170	27,6	0°	0°	

Dimensional drawing shows right-hand version. | Measured with master insert: VB .. 110304 / VB .. 160408 | Refer to the Walter online catalogue for more product information: [www.walter-tools.com](http://www.walter-tools.com) | Bodies and assembly parts are included in the scope of delivery

## Assembly parts

	Type h = h <sub>1</sub> [mm]	VB .. 1103 .. 16–25	VB .. 1604 .. 20–32
	Clamping screw for indexable insert Tightening torque	FS2061 (T7IP) 0,9 Nm	FS2060 (T15IP) 3 Nm
	Shim		AP316-VB1608
	Screw for shim		FS2068 (SW 3,5)
	Torx key	FS1490 (T7IP)	FS1465 (T15IP)

## Accessories

	Type	VB .. 1103 ..	VB .. 1604 ..
	Shim		AP330-VB1612

## Shank tool – Lever clamping

PVHB 

Walter Turn

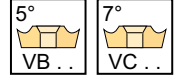
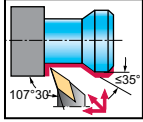

## Tool

Designation		$h = h_1$ mm	b mm	f mm	$l_1$ mm	$l_4$ mm	$\gamma$	$\lambda_s$	Type
PVHBR1616H11		11	16	20	100	25	0°	0°	VB .. 1103 ..
PVHBR2020K11		11	20	25	125	25	0°	0°	
PVHBR2525M11		11	25	32	150	32	0°	0°	
PVHBR2020K16		16	20	25	125	28	0°	0°	VB .. 1604 ..
PVHBR2525M16		16	25	32	150	28	0°	0°	
PVHBR3225P16		16	32	32	170	28	0°	0°	
PVHBL1616H11		11	16	20	100	25	0°	0°	VB .. 1103 ..
PVHBL2020K11		11	20	25	125	25	0°	0°	
PVHBL2525M11		11	25	32	150	32	0°	0°	
PVHBL2020K16		16	20	25	125	28	0°	0°	VB .. 1604 ..
PVHBL2525M16		16	25	32	150	28	0°	0°	
PVHBL3225P16		16	32	32	170	28	0°	0°	

Square shank

Dimensional drawing shows right-hand version. | Measured with master insert: VB .. 110304 / VB .. 160408 | Refer to the Walter online catalogue for more product information: [www.walter-tools.com](http://www.walter-tools.com) | Bodies and assembly parts are included in the scope of delivery

## Assembly parts

Type	h = h <sub>1</sub> [mm]	VB .. 1103 .. 16–25	VB .. 1604 .. 20–32
	Shim		AP153
	Shim pin		RS101
	Lever	KN118	KN110
	Clamping screw Tightening torque	FS347 (SW 2) 0,6 Nm	FS351 (SW 2,5) 2 Nm
	Tapered assembly pin		MD101
	Allen key	ISO2936-2 (SW 2)	ISO2936-2,5 (SW 2,5)

## Accessories

Type	VB .. 1103 ..	VB .. 1604 ..
	Shim	AP154

## Shank tool – Screw clamping

SVJB 

Walter Turn

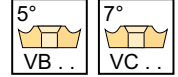
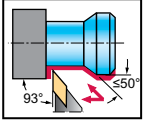

## Tool

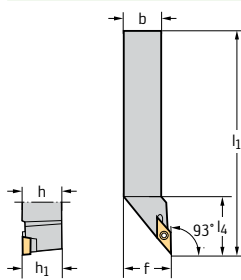

Square shank

Designation		$h = h_1$ mm	b mm	f mm	$l_1$ mm	$l_4$ mm	$\gamma$	$\lambda_s$	Type
SVJBR1212F11		11	12	16	80	20,6	0°	0°	VB .. 1103 ..
SVJBR1616H11		11	16	20	100	21,2	0°	0°	
SVJBR2020K11		11	20	25	125	21,2	0°	0°	
SVJBR2525M11		11	25	32	150	21,2	0°	0°	VB .. 1604 ..
SVJBR1616H16		16	16	20	100	27	0°	0°	
SVJBR2020K16		16	20	25	125	31,1	0°	0°	
SVJBR2525M16		16	25	32	150	31,5	0°	0°	
SVJBR3225P16		16	32	32	170	31,5	0°	0°	VB .. 1103 ..
SVJBL1212F11		11	12	16	80	20,6	0°	0°	
SVJBL1616H11		11	16	20	100	21,2	0°	0°	
SVJBL2020K11		11	20	25	125	21,2	0°	0°	
SVJBL2525M11		11	25	32	150	21,2	0°	0°	
SVJBL1616H16		16	16	20	100	27	0°	0°	
SVJBL2020K16		16	20	25	125	31,1	0°	0°	
SVJBL2525M16		16	25	32	150	31,5	0°	0°	VB .. 1604 ..
SVJBL3225P16		16	32	32	170	31,5	0°	0°	

Dimensional drawing shows right-hand version. | Measured with master insert: VB .. 110304 / VB .. 160408 | Refer to the Walter online catalogue for more product information: [www.walter-tools.com](http://www.walter-tools.com) | Bodies and assembly parts are included in the scope of delivery

## Assembly parts

	Type $h = h_1$ (mm)	VB .. 1103 .. 12–25	VB .. 1103 .. 16	VB .. 1604 .. 16	VB .. 1604 .. 20–32
	Clamping screw for indexable insert Tightening torque	FS2061 (T7IP) 0,9 Nm	FS2061 (T7IP) 0,9 Nm	FS2063 (T15IP) 3 Nm	FS2060 (T15IP) 3 Nm
	Shim		AP316-VB1608		AP316-VB1608
	Screw for shim		FS2068 (SW 3,5)		FS2068 (SW 3,5)
	Torx key	FS1490 (T7IP)	FS1490 (T7IP)	FS1465 (T15IP)	FS1465 (T15IP)

## Accessories

Type	VB .. 1103 ..–VB .. 1604 ..
Shim for radius	AP330-VB1612

## Shank tool – Screw clamping

SVJB inch

Walter Turn

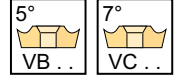
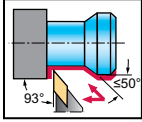

## Tool

Designation		h = h <sub>1</sub> inch	b inch	f inch	l <sub>1</sub> inch	l <sub>4</sub> inch	γ	λ <sub>s</sub>	Type	
SVJBR082	<p>Square shank</p>	11	0,500	0,500	0,625	3,500	0°	0°	VB .. 1103 .. VB .. 22 ..	
SVJBR102		11	0,625	0,625	0,750	4,000	0,835	0°		0°
SVJBR122B		11	0,750	0,750	1,000	4,500	0,835	0°	0°	VB .. 1604 .. VB .. 33 ..
SVJBR123B		16	0,750	0,750	1,000	4,500	1,228	0°	0°	
SVJBR163C		16	1,000	1,000	1,250	5,000	1,24	0°	0°	
SVJBR163D		16	1,000	1,000	1,250	6,000	1,24	0°	0°	
SVJBL082		11	0,500	0,500	0,625	3,500	0,799	0°	0°	VB .. 1103 .. VB .. 22 ..
SVJBL102		11	0,625	0,625	0,750	4,000	0,835	0°	0°	
SVJBL122B		11	0,750	0,750	1,000	4,500	0,835	0°	0°	VB .. 1604 .. VB .. 33 ..
SVJBL123B		16	0,750	0,750	1,000	4,500	1,228	0°	0°	
SVJBL163C		16	1,000	1,000	1,250	5,000	1,24	0°	0°	
SVJBL163D		16	1,000	1,000	1,250	6,000	1,24	0°	0°	

Dimensional drawing shows right-hand version. | Measured with master insert: VB .. 110304 / VB .. 160408 | Refer to the Walter online catalogue for more product information: [www.walter-tools.com](http://www.walter-tools.com) | Bodies and assembly parts are included in the scope of delivery

## Assembly parts

Type	h = h <sub>1</sub> [inch]	VB .. 1103 .. 0,5–0,75	VB .. 1604 .. 0,75–1
Clamping screw for indexable insert Tightening torque		FS2061 (T7IP) 0,664 lbs	FS2060 (T15IP) 2,213 lbs
Shim			AP316-VB1608
Screw for shim			FS2068 (SW 3,5)
Torx key		FS1490 (T7IP)	FS1465 (T15IP)

## Accessories

Type	VB .. 1103 ..	VB .. 1604 ..
Shim		AP330-VB1612

## Shank tool – Screw clamping

SVJB...-P 

## Walter Turn

– Precision cooling

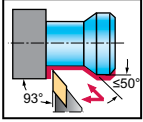

## Tool

Designation	h = h <sub>1</sub> mm	b mm	f mm	l <sub>1</sub> mm	l <sub>4</sub> mm	γ	λ <sub>s</sub>	T <sub>h</sub>	Type
SVJBR2020X16-P	16	20	25	110	33,5	0°	0°	G1/8"	VB .. 1604 ..
SVJBR2525X16-P	16	25	32	125	33,5	0°	0°	G1/8"	
SVJBL2020X16-P	16	20	25	110	33,5	0°	0°	G1/8"	VB .. 1604 ..
SVJBL2525X16-P	16	25	32	125	33,5	0°	0°	G1/8"	

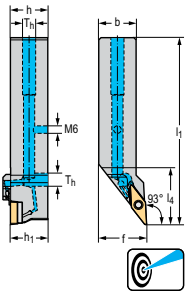

Square shank

Dimensional drawing shows right-hand version. | Measured with master insert: VB .. 160408 | The maximum recommended coolant pressure is 150 bar (2175 psi) | Refer to the Walter online catalogue for more product information: [www.walter-tools.com](http://www.walter-tools.com) | Bodies and assembly parts are included in the scope of delivery

## Assembly parts

Assembly parts	Type h = h <sub>1</sub> (mm)	VB .. 1604 .. 20–25
	Clamping screw for indexable insert Tightening torque	FS2060 (T15IP) 3 Nm
	Shim	AP316-VB1608
	Screw for shim	FS2068 (SW 3,5)
	M6 threaded plug	FS2288 (SW 3)
	G 1/8" threaded plug	FS2258 (SW 2)
	Torx key	FS1465 (T15IP)

## Shank tool – Screw clamping

SVJB...-S-P 

## Walter Turn

- Precision cooling
- For Swiss Machining

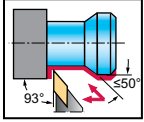

## Tool

Designation	h = h <sub>1</sub> mm	b mm	f mm	l <sub>1</sub> mm	l <sub>4</sub> mm	γ	λ <sub>s</sub>	T <sub>h</sub>	Type
SVJBR1010H11-S-P	11	10	10	100	22	0°	0°	M6	VB .. 1103 ..
SVJBR1212J11-S-P	11	12	12	110	22	0°	0°	M8X1	
SVJBR1616X11-S-P	11	16	16	120	22	0°	0°	G1/8"	
SVJBL1010H11-S-P	11	10	10	100	22	0°	0°	M6	VB .. 1103 ..
SVJBL1212J11-S-P	11	12	12	110	22	0°	0°	M8X1	
SVJBL1616X11-S-P	11	16	16	120	22	0°	0°	G1/8"	

Square shank

Dimensional drawing shows right-hand version. | Measured with master insert: VB .. 110304 | The maximum recommended coolant pressure is 150 bar (2175 psi) | Refer to the Walter online catalogue for more product information: [www.walter-tools.com](http://www.walter-tools.com) | Bodies and assembly parts are included in the scope of delivery

## Assembly parts

Type h = h <sub>1</sub> [mm]	VB .. 1103 .. 10	VB .. 1103 .. 12	VB .. 1103 .. 16
Clamping screw for indexable insert Tightening torque	FS2061 (T7IP) 0,9 Nm	FS2061 (T7IP) 0,9 Nm	FS2061 (T7IP) 0,9 Nm
G 1/8" threaded plug			FS2258 (SW 2)
M8X1 threaded plug		FS2587 (SW 4)	
M6 threaded plug	FS2288 (SW 3)		
Torx key	FS1490 (T7IP)	FS1490 (T7IP)	FS1490 (T7IP)

## Accessories

Type h = h <sub>1</sub> [mm]	VB .. 1103 .. 10-16	VB .. 1103 .. 12
M8x1 angle connection		FS2596
M8x1 connection element		FS2597
Copper gasket		FS2598

# Shank tool – Rigid clamping

DVJB...-P mm

**Walter Turn**



– Precision cooling

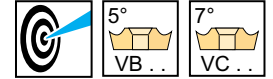
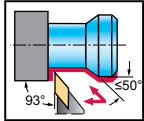

Tool	Designation	 $h = h_1$ mm		b mm	$b_1$ mm	f mm	$l_1$ mm	$l_4$ mm	$\gamma$	$\lambda_s$	Type
		h	h <sub>1</sub>								
	DVJBR2020X16-P	16	20	20	4	25	125	48,5	-2°	-7°	VB .. 1604 ..
	DVJBR2525X16-P	16	25	25	0	32	140	48,5	-2°	-7°	
	DVJBL2020X16-P	16	20	20	4	25	125	48,5	-2°	-7°	VB .. 1604 ..
	DVJBL2525X16-P	16	25	25	0	32	140	48,5	-2°	-7°	

Square shank

Dimensional drawing shows right-hand version. | Measured with master insert: VB .. 160408 | For the connection set for internal coolant supply with G1/8" thread, see „Assembly parts and accessories“ | The maximum recommended coolant pressure is 150 bar (2175 psi) | Refer to the Walter online catalogue for more product information: [www.walter-tools.com](http://www.walter-tools.com) | Bodies and assembly parts are included in the scope of delivery

Assembly parts		Type	VB .. 1604 ..
		h = h <sub>1</sub> [mm]	20–25
	Shim		AP312-VN16
	Screw for shim Tightening torque		FS1467 (T15IP) 3 Nm
	Right clamp		PK261R
	Left clamp		PK261L
	Screw for clamp Tightening torque		FS1473 (T15IP) 3,9 Nm
	Pressure spring		FS2188
	G 1/8" threaded plug		FS2258 (SW 2)
	M6 threaded plug		FS2288 (SW 3)
	Torx key		FS1465 (T15IP)

Accessories		Type	VB .. 1604 ..
	(standard assembly parts) Right clamp set		PK261R-SET
	(standard assembly parts) Left clamp set		PK261L-SET

## Shank tool – Lever clamping

PVJB 

Walter Turn

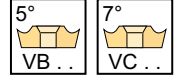
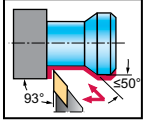
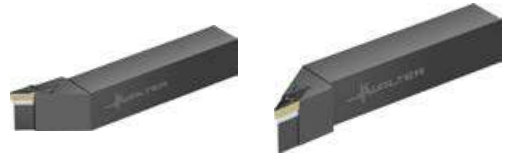

## Tool

Designation		$h = h_1$ mm	b mm	f mm	$l_1$ mm	$l_4$ mm	$\gamma$	$\lambda_s$	Type
PVJBR1616H11		11	16	20	100	25	0°	0°	VB .. 1103 ..
PVJBR2020K11		11	20	25	125	25	0°	0°	
PVJBR2525M11		11	25	32	150	32	0°	0°	
PVJBR1616H16		16	16	20	100	32	0°	0°	VB .. 1604 ..
PVJBR2020K16		16	20	25	125	34	0°	0°	
PVJBR2525M16		16	25	32	150	38	0°	0°	
PVJBR3225P16		16	32	32	170	38	0°	0°	VB .. 1103 ..
PVJBL1616H11		11	16	20	100	25	0°	0°	
PVJBL2020K11		11	20	25	125	25	0°	0°	
PVJBL2525M11		11	25	32	150	32	0°	0°	VB .. 1604 ..
PVJBL1616H16		16	16	20	100	32	0°	0°	
PVJBL2020K16		16	20	25	125	34	0°	0°	
PVJBL2525M16		16	25	32	150	38	0°	0°	
PVJBL3225P16		16	32	32	170	38	0°	0°	

Square shank

Dimensional drawing shows right-hand version. | Measured with master insert: VB .. 110304 / VB .. 160408 | Refer to the Walter online catalogue for more product information: [www.walter-tools.com](http://www.walter-tools.com) | Bodies and assembly parts are included in the scope of delivery

## Assembly parts

Type $h = h_1$ [mm]	VB .. 1103 .. 16–25	VB .. 1604 .. 16	VB .. 1604 .. 20–32
Shim		AP153	AP153
Shim pin		RS101	RS101
Lever	KN118	KN110	KN110
Clamping screw Tightening torque	FS347 (SW 2) 0,6 Nm	FS332 (SW 2,5) 2,5 Nm	FS351 (SW 2,5) 2 Nm
Tapered assembly pin		MD101	MD101
Allen key	ISO2936-2 (SW 2)	ISO2936-2,5 (SW 2,5)	ISO2936-2,5 (SW 2,5)

## Accessories

Type	VB .. 1103 ..	VB .. 1604 ..
Shim		AP154



# Shank tool – Screw clamping

SVVB

Walter Turn

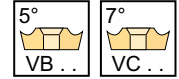
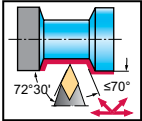

Tool	Designation		h = h <sub>1</sub> mm	b mm	f mm	l <sub>1</sub> mm	l <sub>4</sub> mm	γ	λ <sub>s</sub>	Type
	SVVBN1212F11	11	12	12	6,3	80	21,1	0°	0°	VB .. 1103 ..
	SVVBN1616H11	11	16	16	8,3	100	21,1	0°	0°	
	SVVBN2020K11	11	20	20	10,3	125	21,1	0°	0°	
	SVVBN2525M11	11	25	25	12,8	150	21,1	0°	0°	
	SVVBN2020K16	16	20	20	10,6	125	31,5	0°	0°	VB .. 1604 ..
	SVVBN2525M16	16	25	25	13,1	150	31,5	0°	0°	
	SVVBN3225P16	16	32	25	13,1	170	31,5	0°	0°	

Square shank

Measured with master insert: VB .. 110304 / VB .. 160408 | Refer to the Walter online catalogue for more product information: [www.walter-tools.com](http://www.walter-tools.com) | Bodies and assembly parts are included in the scope of delivery

Assembly parts		VB .. 1103 .. 12–25	VB .. 1604 .. 20–32
	Clamping screw for indexable insert Tightening torque	FS2061 (T7IP) 0,9 Nm	FS2060 (T15IP) 3 Nm
	Shim		AP316-VB1608
	Screw for shim		FS2068 (SW 3,5)
	Torx key	FS1490 (T7IP)	FS1465 (T15IP)

Accessories		VB .. 1103 ..	VB .. 1604 ..
	Shim		AP330-VB1612

## Shank tool – Screw clamping

SVVB inch

Walter Turn

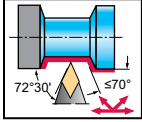

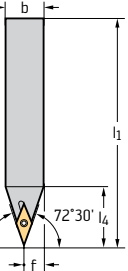
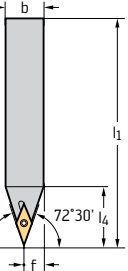

## Tool

Designation		$h = h_1$ inch	b inch	f inch	$l_1$ inch	$l_4$ inch	$\gamma$	$\lambda_s$	Type	
SVVBN123B		16	0,750	0,750	0,395	4,500	1,24	0°	0°	VB .. 1604 ..
SVVBN163D		16	1,000	1,000	0,52	6,000	1,24	0°	0°	VB .. 33 ..

Square shank

Measured with master insert: VB .. 160408 | Refer to the Walter online catalogue for more product information: [www.walter-tools.com](http://www.walter-tools.com) | Bodies and assembly parts are included in the scope of delivery

## Assembly parts

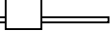
	Type $h = h_1$ [inch]	VB .. 1604 .. 0,75-1
	Clamping screw for indexable insert Tightening torque	FS2060 (T15IP) 2,213 lbs
	Shim	AP316-VB1608
	Screw for shim	FS2068 (SW 3,5)
	Torx key	FS1465 (T15IP)

## Accessories

	Type	VB .. 1604 ..
	Shim	AP330-VB1612

# Shank tool – Lever clamping

PVVB

Walter Turn

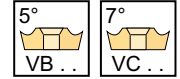
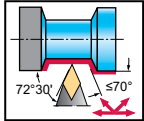

Tool	Designation		h = h <sub>1</sub> mm	b mm	f mm	l <sub>1</sub> mm	l <sub>4</sub> mm	γ	λ <sub>s</sub>	Type
<p>Square shank</p>	PVVBN2020K11		11	20	10	125	25	0°	0°	VB .. 1103 ..
	PVVBN2525M11		11	25	12,5	150	25	0°	0°	
	PVVBN2020K16		16	20	10	125	34	0°	0°	VB .. 1604 ..
	PVVBN2525M16		16	25	12,5	150	34	0°	0°	
	PVVBN3225P16		16	32	12,5	170	34	0°	0°	

Measured with master insert: VB .. 110304 / VB .. 160408 | Refer to the Walter online catalogue for more product information: [www.walter-tools.com](http://www.walter-tools.com) | Bodies and assembly parts are included in the scope of delivery

Assembly parts	Type h = h <sub>1</sub> [mm]	VB .. 1103 .. 20–25	VB .. 1604 .. 20–32
	Shim		AP153
	Lever	KN118	KN110
	Clamping screw Tightening torque	FS347 (SW 2) 0,6 Nm	FS351 (SW 2,5) 2 Nm
	Shim pin		RS101
	Tapered assembly pin		MD101
	Allen key	ISO2936-2 (SW 2)	ISO2936-2.5 (SW 2,5)

Accessories	Type	VB .. 1103 ..	VB .. 1604 ..
	Shim		AP154

## Shank tool – Screw clamping

SWLC 

Walter Turn

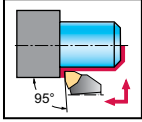

## Tool

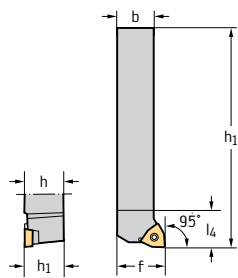

Square shank

Designation		h = h <sub>1</sub> mm	b mm	f mm	l <sub>1</sub> mm	l <sub>4</sub> mm	γ	λ <sub>s</sub>	Type
SWLCR1212F04		4	12	16	80	11	0°	0°	WC .. 0402 ..
SWLCR1616H06		6	16	20	100	15	0°	0°	WC .. 06T3 ..
SWLCR2020K06		6	20	25	125	15	0°	0°	
SWLCR2525M06		6	25	32	150	17	0°	0°	
SWLCR2020K08		8	20	25	125	20	0°	0°	WC .. 0804 ..
SWLCR2525M08		8	25	32	150	21	0°	0°	
SWLCL1212F04		4	12	16	80	11	0°	0°	WC .. 0402 ..
SWLCL1616H06		6	16	20	100	15	0°	0°	WC .. 06T3 ..
SWLCL2020K06		6	20	25	125	15	0°	0°	
SWLCL2525M06		6	25	32	150	17	0°	0°	
SWLCL2020K08		8	20	25	125	20	0°	0°	WC .. 0804 ..
SWLCL2525M08		8	25	32	150	21	0°	0°	

Dimensional drawing shows right-hand version. | Measured with master insert: WC .. 040204 / WC .. 06T308 / WC .. 080408 | Refer to the Walter online catalogue for more product information: [www.walter-tools.com](http://www.walter-tools.com) | Bodies and assembly parts are included in the scope of delivery

## Assembly parts

	Type h = h <sub>1</sub> [mm]	WC .. 0402 .. 12	WC .. 06T3 .. 16–25	WC .. 0804 .. 20–25
	Clamping screw for indexable insert Tightening torque	FS2067 (T7IP) 0,9 Nm	FS2063 (T15IP) 3 Nm	FS2065 (T15IP) 3 Nm
	Shim		AP318-WC0608	AP320-WC0812
	Screw for shim		FS2068 (SW 3,5)	FS2069 (SW 4)
	Torx key	FS1490 (T7IP)	FS1465 (T15IP)	FS1496 (T15IP)

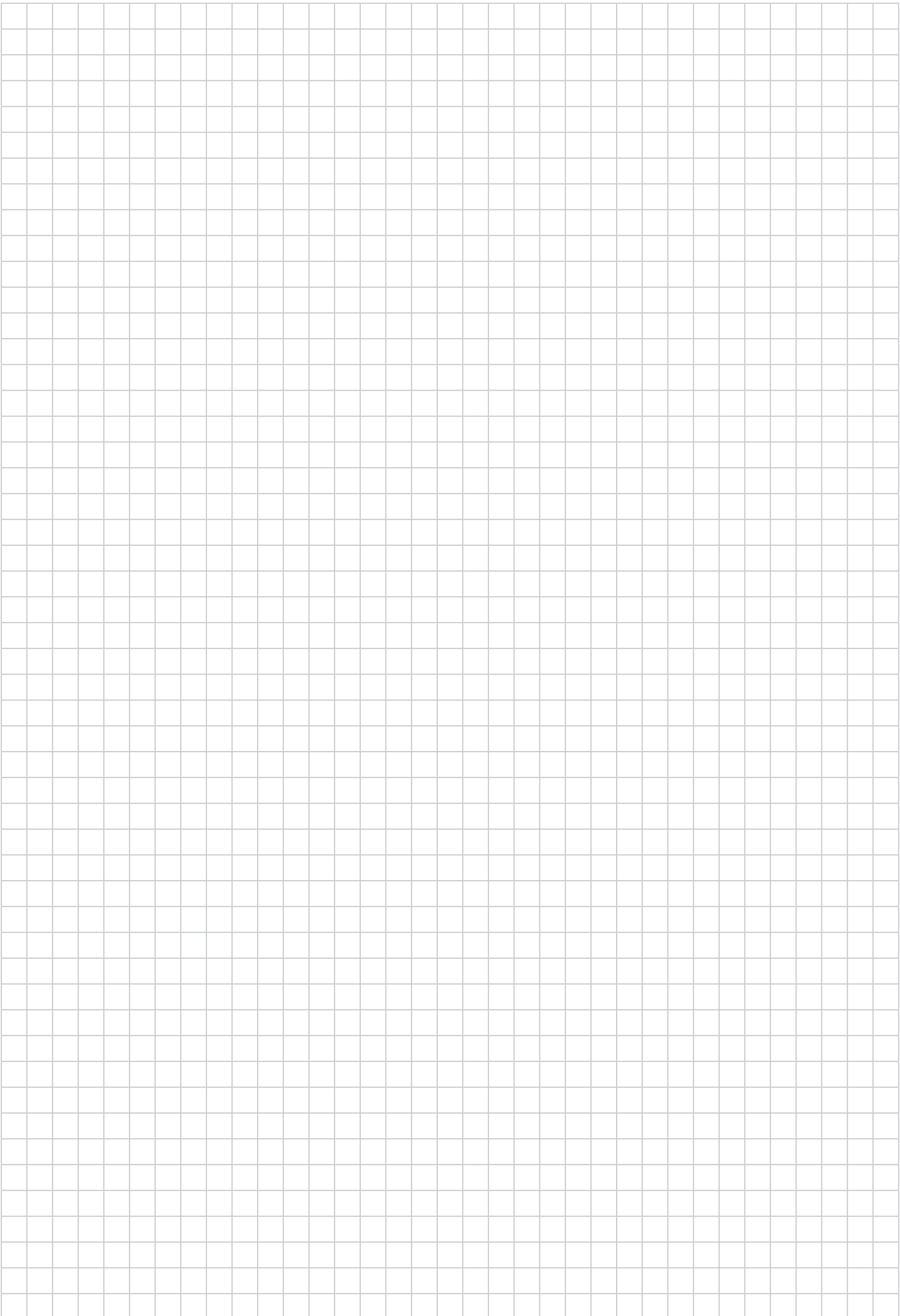

## Shank tool – Copy turning system

W1011 

Walter Turn



– With WL form-fit system

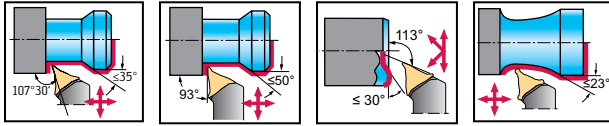

## Tool

		Designation		h = h <sub>1</sub> mm	b mm	f mm	l <sub>1</sub> mm	l <sub>4</sub> mm	γ	λ <sub>s</sub>	Type
		W1011-1616R-WL25		25	16	20	100	33,5	0°	0°	WL25..
		W1011-2020R-WL25		25	20	25	125	33,5	0°	0°	
		W1011-2525R-WL25		25	25	32	150	33,5	0°	0°	
		W1011-1616L-WL25		25	16	20	100	33,5	0°	0°	WL25..
		W1011-2020L-WL25		25	20	25	125	33,5	0°	0°	
		W1011-2525L-WL25		25	25	32	150	33,5	0°	0°	

Square shank

Dimensional drawing shows right-hand version. | Measured with master insert:WL25-VC0708N-MM4 | Refer to the Walter online catalogue for more product information: [www.walter-tools.com](http://www.walter-tools.com) | Bodies and assembly parts are included in the scope of delivery

## Assembly parts

	Type	WL25..
	Clamping screw for indexable insert Tightening torque	FS1495 (T20IP) 5 Nm
	Allen key	FS1464 (T20IP)

# Shank tool – Copy turning system

W1011...-P

## Walter Turn



- Precision cooling
- With WL form-fit system

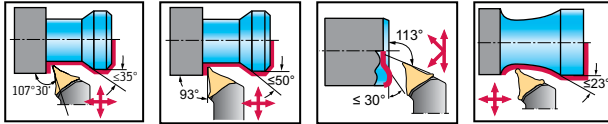

Tool	Designation		h = h <sub>1</sub> mm	b mm	f mm	l <sub>1</sub> mm	l <sub>4</sub> mm	γ	λ <sub>s</sub>	Type
<p>Square shank</p>	W1011-2020R-WL17-P	17	20	20	25	125	25	0°	0°	WL17..
	W1011-1616R-WL25-P	25	16	16	20	115	30	0°	0°	WL25..
	W1011-2020R-WL25-P	25	20	20	25	115	33,5	0°	0°	
	W1011-2525R-WL25-P	25	25	25	32	130	33,5	0°	0°	
	W1011-3225R-WL25-P	25	32	25	32	140	36,5	0°	0°	
	W1011-2020L-WL17-P	17	20	20	25	125	25	0°	0°	WL17..
	W1011-1616L-WL25-P	25	16	16	20	115	30	0°	0°	WL25..
	W1011-2020L-WL25-P	25	20	20	25	115	33,5	0°	0°	
	W1011-2525L-WL25-P	25	25	25	32	130	33,5	0°	0°	
	W1011-3225L-WL25-P	25	32	25	32	140	36,5	0°	0°	

Dimensional drawing shows right-hand version. | Measured with master insert: WL25-VC0708N-MM4 / WL17-VC050804N-FM4 | For the connection set for internal coolant supply with G1/8" thread, see „Assembly parts and accessories“ | The maximum recommended coolant pressure is 150 bar (2175 psi) | Refer to the Walter online catalogue for more product information: [www.walter-tools.com](http://www.walter-tools.com) | Bodies and assembly parts are included in the scope of delivery

Assembly parts		WL17..	WL25..
	Clamping screw for indexable insert Tightening torque	FS1457 (T9IP) 2 Nm	FS1495 (T20IP) 5 Nm
	G 1/8" threaded plug	FS2258 (SW 2)	FS2258 (SW 2)
	M6 threaded plug	FS2288 (SW 3)	FS2288 (SW 3)
	Allen key		FS1464 (T20IP)
	Torx key	FS1466 (T9IP)	

●● Primary application   ● Other application  
 Best tool for → Good = 😊 → Average = 😐 → Poor = 😞 machining conditions

## Shank tool – Copy turning system

W1011...-P inch

Walter Turn



- Precision cooling
- With WL form-fit system

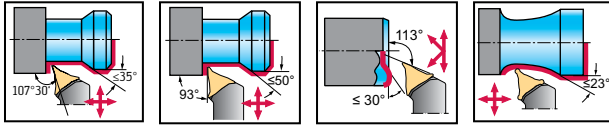

### Tool

	Designation		h = h <sub>1</sub> inch	b inch	f inch	l <sub>1</sub> inch	l <sub>4</sub> inch	γ	λ <sub>s</sub>	Type
										WL25..
	W1011.12R-WL25-P		25	0,750	1,000	4,500	1,319	0°	0°	WL25..
	W1011.16R-WL25-P		25	1,000	1,250	6,000	1,319	0°	0°	WL25..
	W1011.12L-WL25-P		25	0,750	1,000	4,500	1,319	0°	0°	WL25..
	W1011.16L-WL25-P		25	1,000	1,250	6,000	1,319	0°	0°	WL25..

Square shank

Dimensional drawing shows right-hand version. | Measured with master insert:WL25-VC0708N-MM4 | For the connection set for internal coolant supply with G1/8" thread, see „Assembly parts and accessories“ | The maximum recommended coolant pressure is 150 bar (2175 psi) | Refer to the Walter online catalogue for more product information: [www.walter-tools.com](http://www.walter-tools.com) | Bodies and assembly parts are included in the scope of delivery

### Assembly parts

	Type	WL25..
	Clamping screw for indexable insert Tightening torque	FS1495 (T20IP) 3,688 lbs
	G 1/8" threaded plug	FS2258 (SW 2)
	M6 threaded plug	FS2288 (SW 3)
	Allen key	FS1464 (T20IP)

WALTER  
SELECT

●● Primary application ● Other application  
Best tool for → Good = 😊 → Average = 😐 → Poor = ☹️ machining conditions



# Shank tool – Copy turning system

W1011...-S-P mm

Walter Turn

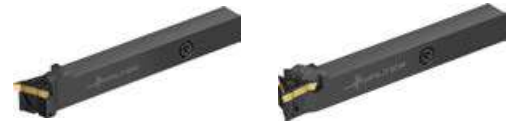

- Precision cooling
- For Swiss Machining

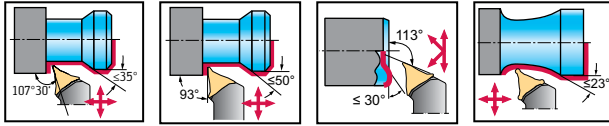

Tool	Designation		h = h <sub>1</sub> mm	b mm	f mm	l <sub>1</sub> mm	l <sub>4</sub> mm	γ	λ <sub>s</sub>	T <sub>h</sub>	Type
											WL17..
	W1011-1212R-WL17-S-P		17	12	12	110	22	0°	0°	M8X1	WL17..
	W1011-1616R-WL17-S-P		17	16	16	110	22	0°	0°	G1/8"	
	W1011-1212L-WL17-S-P		17	12	12	110	22	0°	0°	M8X1	WL17..
	W1011-1616L-WL17-S-P		17	16	16	110	22	0°	0°	G1/8"	

Square shank

Dimensional drawing shows right-hand version. | Measured with master insert:WL17-VC050804R-FM4 | The maximum recommended coolant pressure is 150 bar (2175 psi) | Refer to the Walter online catalogue for more product information: [www.walter-tools.com](http://www.walter-tools.com) | Bodies and assembly parts are included in the scope of delivery

Assembly parts		
Type	WL17..	
	Clamping screw for indexable insert Tightening torque	FS1457 (T9IP) 2 Nm
	G 1/8" threaded plug	FS2258 (SW 2)
	M8X1 threaded plug	FS2587 (SW 4)
	Torx key	FS1466 (T9IP)

Accessories		
Type	WL17..	
	M8x1 angle connection	FS2596
	M8x1 connection element	FS2597
	Copper gasket	FS2598

**WALTER SELECT** ●● Primary application ● Other application

Best tool for → Good = 😊 → Average = 😐 → Poor = ☹️ machining conditions

## Shank tool – Copy turning system

W1010...-P 

Walter Turn



- Precision cooling
- With WL form-fit system

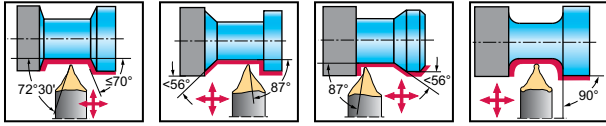

## Tool

Designation		h = h <sub>1</sub> mm	b mm	f mm	l <sub>1</sub> mm	l <sub>4</sub> mm	$\gamma$	$\lambda_s$	Type
W1010-1616N-WL17-P		17	16	8	120	22	0°	0°	WL17..
W1010-2020N-WL25-P		25	20	10	115	33,5	0°	0°	WL25..
W1010-2525N-WL25-P		25	25	13	130	33,5	0°	0°	WL25..

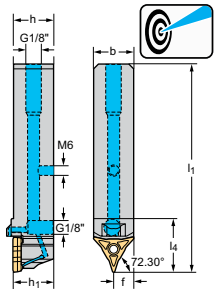

Square shank

Measured with master insert: WL17-VC050804N-FM4 / WL25-VC0708N-MM4 | The maximum recommended coolant pressure is 150 bar (2175 psi) | For the connection set for internal coolant supply with G1/8" thread, see „Assembly parts and accessories“ | Refer to the Walter online catalogue for more product information: [www.walter-tools.com](http://www.walter-tools.com) | Bodies and assembly parts are included in the scope of delivery

## Assembly parts

Type	WL17..	WL25..
Clamping screw for indexable insert Tightening torque	FS1457 (T9IP) 2 Nm	FS1495 (T20IP) 5 Nm
G 1/8" threaded plug	FS2258 (SW 2)	FS2258 (SW 2)
M6 threaded plug		FS2288 (SW 3)
Torx key	FS1466 (T9IP)	
Allen key		FS1464 (T20IP)

**WALTER  
SELECT**

●● Primary application ● Other application  
Best tool for → Good = 😊 → Average = 😐 → Poor = 😞 machining conditions

# Shank tool – Copy turning system

W1010...-P inch

Walter Turn



- Precision cooling
- With WL form-fit system

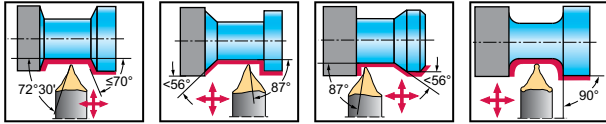

Tool		Designation		h = h <sub>1</sub> inch	b inch	f inch	l <sub>1</sub> inch	l <sub>4</sub> inch	γ	λ <sub>s</sub>	Type
		W1010.12N-WL25-P	25	0,750	0,750	0,375	4,500	1,319	0°	0°	WL25..
		W1010.16N-WL25-P	25	1,000	1,000	0,500	6,000	1,319	0°	0°	

Square shank

Measured with master insert:WL25-VC0708N-MM4 | The maximum recommended coolant pressure is 150 bar (2175 psi) | For the connection set for internal coolant supply with G1/8" thread, see „Assembly parts and accessories“ | Refer to the Walter online catalogue for more product information: [www.walter-tools.com](http://www.walter-tools.com) | Bodies and assembly parts are included in the scope of delivery

Assembly parts		Type	WL25..
	Clamping screw for indexable insert Tightening torque		FS1495 (T20IP) 3,688 lbs
	G 1/8" threaded plug		FS2258 (SW 2)
	M6 threaded plug		FS2288 (SW 3)
	Allen key		FS1464 (T20IP)

WALTER SELECT

●● Primary application ● Other application

Best tool for → Good = 😊 → Average = 😐 → Poor = 😞 machining conditions

## Shank tool – Rigid clamping

CRSN

### Walter Turn

- For ceramic indexable inserts
- Claw clamping with carbide shoe

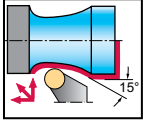

#### Tool

Designation		$h = h_1$ mm	b mm	$l_1$ mm	$l_4$ mm	f mm	$\gamma$	$\lambda_s$	Type
CRSNR2525M12-ID		12	25	150	28	32	-6°	-6°	RNGN1207 ..
CRSNR3225P12-ID		12	32	170	28	32	-6°	-6°	
CRSNR3232P15-ID		15	32	170	30	40	-6°	-6°	RN .. 1507 ..
CRSNL2525M12-ID		12	25	150	28	32	-6°	-6°	RNGN1207 ..
CRSNL3225P12-ID		12	32	170	28	32	-6°	-6°	
CRSNL3232P15-ID		15	32	170	30	40	-6°	-6°	RN .. 1507 ..

Square shank

Dimensional drawing shows right-hand version. | Measured with master insert: RN .. 120700 / RN .. 150700 | Refer to the Walter online catalogue for more product information: [www.walter-tools.com](http://www.walter-tools.com) | Bodies and assembly parts are included in the scope of delivery

#### Assembly parts

Type	h = h <sub>1</sub> [mm]	RN .. 1507 .. 32	RNGN1207 .. 25-32
	Shim	AP419-RN1507	
	Shim for RN .. 1207 ..		AP418-RN1207
	Screw for shim Tightening torque	FS2242 (SW 2) 2 Nm	FS2241 (T20) 5 Nm
	Clamp with screw	PK258-SET	PK258-SET
	Carbide clamping plate	FK380	FK380
	Allen key for clamp	ISO2936-4 (SW 4)	ISO2936-4 (SW 4)
	Torx key for shim		FS256 (T20)
	Allen key for shim	ISO2936-2 (SW 2)	

#### Accessories

Type	RN .. 1507 ..	RNGN1207 ..
	Shim for RN .. 1204 ..	AP421-RN1204

## Shank tool - Rigid clamping

CRSN...-P 

## Walter Turn

- Precision cooling
- For ceramic indexable inserts

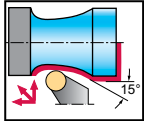

## Tool

Designation		h = h <sub>1</sub> mm	b mm	b <sub>1</sub> mm	l <sub>1</sub> mm	l <sub>4</sub> mm	f mm	γ	λ <sub>s</sub>	Type
CRSNR2525X12-P		12	25	10	130	38,5	32	-6°	-6°	RNGN1207 ..
CRSNL2525X12-P		12	25	10	130	38,5	32	-6°	-6°	RNGN1207 ..

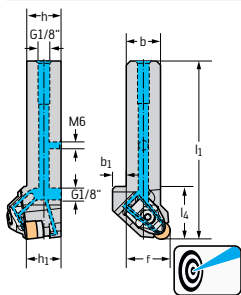

Square shank

Dimensional drawing shows right-hand version. | Measured with master insert: RN .. 120700 | For the connection set for internal coolant supply with G1/8" thread, see „Assembly parts and accessories“ | The maximum recommended coolant pressure is 150 bar (2175 psi) | Refer to the Walter online catalogue for more product information: [www.walter-tools.com](http://www.walter-tools.com) | Bodies and assembly parts are included in the scope of delivery

## Assembly parts

Type	h = h <sub>1</sub> [mm]	RNGN1207 ..
	Shim for RN .. 1207 ..	AP418-RN1207
	Screw for shim Tightening torque	FS2241 (T20) 5 Nm
	Clamp	PK268
	Screw for clamp Tightening torque	FS1474 (T20IP) 6,4 Nm
	Pressure spring	FS2298
	G 1/8" threaded plug	FS2258 (SW 2)
	M6 threaded plug	FS2288 (SW 3)
	Allen key	FS1464 (T20IP)

## Accessories

Type	RNGN1207 ..
 (standard assembly parts) Clamp set	PK268-SET
	Shim for RN .. 1204 ..

## Shank tool – Rigid clamping

CRDN

### Walter Turn

- For ceramic indexable inserts
- Claw clamping with carbide shoe

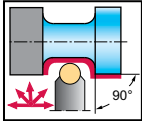

#### Tool

Designation		h = h <sub>1</sub> mm	b mm	l <sub>1</sub> mm	l <sub>4</sub> mm	f mm	γ	λ <sub>s</sub>	Type
CRDNN2525M12-ID	12	25	25	150	32	18,8	-8°	0°	RNGN1207 ..
CRDNN3225P12-ID	12	32	25	170	32	18,8	-8°	0°	

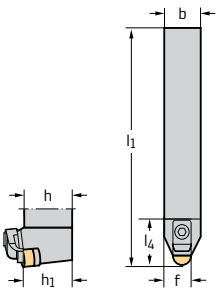

Square shank

Measured with master insert: RN .. 120700 | Refer to the Walter online catalogue for more product information: [www.walter-tools.com](http://www.walter-tools.com) | Bodies and assembly parts are included in the scope of delivery

#### Assembly parts

Type	h = h <sub>1</sub> [mm]	RNGN1207 .. 25-32
	Shim for RN .. 1207 ..	AP418-RN1207
	Screw for shim Tightening torque	FS2241 (T20) 5 Nm
	Clamp with screw	PK258-SET
	Carbide clamping plate	FK380
	Allen key for clamp	ISO2936-4 (SW 4)
	Torx key	FS256 (T20)

#### Accessories

Type	RNGN1207 ..
	Shim for RN .. 1204 .. AP421-RN1204

## Shank tool – Rigid clamping

CRDC

### Walter Turn



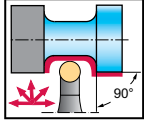

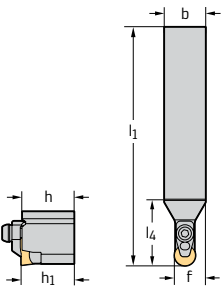
- For ceramic indexable inserts
- Claw clamping with carbide shoe



Tool	Designation		h = h <sub>1</sub> mm	b mm	f mm	l <sub>1</sub> mm	l <sub>4</sub> mm	γ	λ <sub>s</sub>	Type
	CRDCN3225P09-A	9	32	25	17,2	170	31	0°	0°	RC . X0907 .. RP . X0907 ..
	CRDCN3225P12-A	12	32	25	18,8	170	40	0°	0°	RC . X1207 .. RP . X1207 ..

Square shank

Measured with master insert: RC .. 090700 / RC .. 120700 | Refer to the Walter online catalogue for more product information: [www.walter-tools.com](http://www.walter-tools.com) | Bodies and assembly parts are included in the scope of delivery

Assembly parts	Type h = h <sub>1</sub> (mm)	RC . X0907 ..	RC . X1207 ..
		32	32
	Shim	AP416-RC0907	AP417-RC1207
	Clamping sleeve	RS121	RS122
	Clamp with screw	PK257-SET	PK257-SET
	Screw for clamp Tightening torque	FS2240 (SW 4) 8 Nm	FS2240 (SW 4) 8 Nm
	Allen key for clamp	ISO2936-4 (SW 4)	ISO2936-4 (SW 4)

## Turning tools – Rigid clamping

C...-DCLN 

## Walter Turn

– Walter Capto™

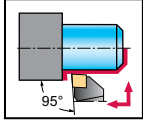

## Tool

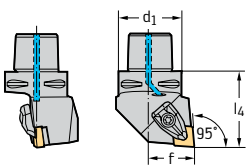

Walter Capto™ in acc. with ISO 26623





Designation		d <sub>1</sub>	f mm	l <sub>4</sub> mm	D <sub>min</sub> mm	D <sub>min2</sub> mm	γ	λ <sub>s</sub>	Type
C4-DCLNR-27050-12	12	C4	27	50	110	140	-6°	-6°	CN .. 1204 ..
C5-DCLNR-35060-12	12	C5	35	60	110	165	-6°	-6°	
C6-DCLNR-45065-12	12	C6	45	65	110	190	-6°	-6°	
C8-DCLNR-55080-12	12	C8	55	80	110	250	-6°	-6°	
C4-DCLNR-27055-16	16	C4	27	55	125	145	-6°	-6°	CN .. 1606 ..
C5-DCLNR-35060-16	16	C5	35	60	125	165	-6°	-6°	
C6-DCLNR-45065-16	16	C6	45	65	125	190	-6°	-6°	
C8-DCLNR-55080-16	16	C8	55	80	125	250	-6°	-6°	
C5-DCLNR-35060-19	19	C5	35	60	80	165	-6°	-6°	CN .. 1906 ..
C6-DCLNR-45065-19	19	C6	45	65	81	190	-6°	-6°	
C8-DCLNR-55080-19	19	C8	55	80	100	250	-6°	-6°	
C4-DCLNL-27050-12	12	C4	27	50	110	140	-6°	-6°	CN .. 1204 ..
C5-DCLNL-35060-12	12	C5	35	60	110	165	-6°	-6°	
C6-DCLNL-45065-12	12	C6	45	65	110	190	-6°	-6°	
C8-DCLNL-55080-12	12	C8	55	80	110	250	-6°	-6°	
C4-DCLNL-27055-16	16	C4	27	55	125	145	-6°	-6°	CN .. 1606 ..
C5-DCLNL-35060-16	16	C5	35	60	125	165	-6°	-6°	
C6-DCLNL-45065-16	16	C6	45	65	125	190	-6°	-6°	
C8-DCLNL-55080-16	16	C8	55	80	125	250	-6°	-6°	
C5-DCLNL-35060-19	19	C5	35	60	80	165	-6°	-6°	CN .. 1906 ..
C6-DCLNL-45065-19	19	C6	45	65	81	190	-6°	-6°	
C8-DCLNL-55080-19	19	C8	55	80	100	50	-6°	-6°	

Dimensional drawing shows right-hand version. | Measured with master insert: CN .. 120408 / CN .. 160612 / CN .. 190612 | Refer to the Walter online catalogue for more product information: [www.walter-tools.com](http://www.walter-tools.com) | Bodies and assembly parts are included in the scope of delivery

## Assembly parts

	Type d <sub>1</sub>	CN .. 1204 .. C4–C8	CN .. 1606 .. C4–C8	CN .. 1906 .. C5–C8
	Shim	AP301-CN12	AP302-CN16	AP303-CN19
	Screw for shim Tightening torque	FS1461 (T15IP) 2,5 Nm	FS1463 (T20IP) 5 Nm	FS1463 (T20IP) 5 Nm
	Clamp	PK241	PK242	PK243
	Screw for clamp Tightening torque	FS1473 (T15IP) 3,9 Nm	FS1474 (T20IP) 6,4 Nm	FS1474 (T20IP) 6,4 Nm
	Pressure spring	FS1470	FS1471	FS1471
	Pin	RS117	RS117	RS117
	Cooling nozzle	FS1475	FS1475	FS1475
	Torx key	FS1465 (T15IP)		
	Allen key		FS1464 (T20IP)	FS1464 (T20IP)



Accessories				
	Type	CN .. 1204 ..	CN .. 1606 ..	CN .. 1906 ..
	(standard assembly parts) Clamp set	PK241-SET	PK242-SET	PK243-SET
	Insert with hole Carbide clamp set	PK245-SET	PK246-SET	
	Insert with hole Carbide clamp set	PK254-SET		
	Shim for CN .. 1207 ..	AP411-CN1207		

## Turning tools – Rigid clamping

C...-DCLN...-P 

## Walter Turn

- Precision cooling
- Walter Capto™

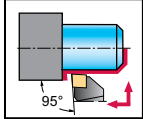

## Tool

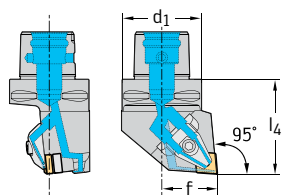

Walter Capto™ in acc. with ISO 26623

Designation		d <sub>1</sub>	f mm	l <sub>4</sub> mm	D <sub>min</sub> mm	D <sub>min2</sub> mm	γ	λ <sub>s</sub>	Type
C4-DCLNR-27050-12-P	12	C4	27	50	500	500	-6°	-6°	CN .. 1204 ..
C5-DCLNR-35060-12-P	12	C5	35	60	600	600	-6°	-6°	
C6-DCLNR-45065-12-P	12	C6	45	65	600	600	-6°	-6°	
C8-DCLNR-55080-12-P	12	C8	55	80	700	700	-6°	-6°	
C5-DCLNR-35060-16-P	16	C5	35	60	600	600	-5,5°	-6,4°	CN .. 1606 ..
C6-DCLNR-45065-16-P	16	C6	45	65	600	600	-6°	-6°	
C8-DCLNR-55080-16-P	16	C8	55	80	700	700	-5,5°	-6,4°	
C4-DCLNL-27050-12-P	12	C4	27	50	500	500	-6°	-6°	CN .. 1204 ..
C5-DCLNL-35060-12-P	12	C5	35	60	600	600	-6°	-6°	
C6-DCLNL-45065-12-P	12	C6	45	65	600	600	-6°	-6°	
C8-DCLNL-55080-12-P	12	C8	55	80	700	700	-6°	-6°	
C5-DCLNL-35060-16-P	16	C5	35	60	600	600	-5,5°	-6,4°	CN .. 1606 ..
C6-DCLNL-45065-16-P	16	C6	45	65	600	600	-6°	-6°	
C8-DCLNL-55080-16-P	16	C8	55	80	700	700	-5,5°	-6,4°	

Dimensional drawing shows right-hand version. | Measured with master insert: CN .. 120408 / CN .. 160612 | The maximum recommended coolant pressure is 150 bar (2175 psi) | Refer to the Walter online catalogue for more product information: [www.walter-tools.com](http://www.walter-tools.com) | Bodies and assembly parts are included in the scope of delivery

## Assembly parts

Type	d <sub>1</sub>	CN .. 1204 .. C4-C8	CN .. 1606 .. C5-C8
	Shim	AP301-CN12	AP302-CN16
	Screw for shim Tightening torque	FS1461 (T15IP) 2,5 Nm	FS1463 (T20IP) 5 Nm
	Clamp	PK255	PK267
	Screw for clamp Tightening torque	FS1473 (T15IP) 3,9 Nm	FS1474 (T20IP) 6,4 Nm
	Pressure spring	FS2188	FS2298
	Torx key	FS1465 (T15IP)	
	Allen key		FS1464 (T20IP)

## Accessories

Type	CN .. 1204 ..	CN .. 1606 ..
 (standard assembly parts) Clamp set	PK255-SET	PK267-SET

## Turning tools – Lever clamping

C...-PCLN 

## Walter Turn

– Walter Capto™

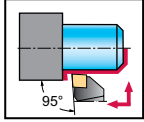

Tool		Designation		$d_1$	f mm	$l_4$ mm	$D_{min}$ mm	$D_{min2}$ mm	$\gamma$	$\lambda_s$	Type	
  Walter Capto™ in acc. with ISO 26623		C3-PCLNR-22040-12		12	C3	22	40	60	116	-6°	-6°	CN .. 1204 ..
		C4-PCLNR-27050-12		12	C4	27	50	60	140	-6°	-6°	
		C5-PCLNR-35060-12		12	C5	35	60	65	165	-6°	-6°	
		C6-PCLNR-45065-12		12	C6	45	65	81	190	-6°	-6°	
		C8-PCLNR-55080-12		12	C8	55	80	100	250	-6°	-6°	
		C4-PCLNR-27050-16		16	C4	27	50	80	140	-6°	-6°	CN .. 1606 ..
		C5-PCLNR-35060-16		16	C5	35	60	80	165	-6°	-6°	
		C6-PCLNR-45065-16		16	C6	45	65	81	190	-6°	-6°	
		C8-PCLNR-55080-16		16	C8	55	80	100	250	-6°	-6°	
		C6-PCLNR-45065-19		19	C6	45	65	81	190	-6°	-6°	CN .. 1906 ..
	C8-PCLNR-55080-19		19	C8	55	80	100	250	-6°	-6°		
	C8-PCLNR-55080-25		25	C8	55	80	150	250	-6°	-6°	CN .. 2509 ..	
	C3-PCLNL-22040-12		12	C3	22	40	60	116	-6°	-6°	CN .. 1204 ..	
	C4-PCLNL-27050-12		12	C4	27	50	60	140	-6°	-6°		
	C5-PCLNL-35060-12		12	C5	35	60	65	165	-6°	-6°		
	C6-PCLNL-45065-12		12	C6	45	65	81	190	-6°	-6°		
	C8-PCLNL-55080-12		12	C8	55	80	100	250	-6°	-6°		
	C4-PCLNL-27050-16		16	C4	27	50	80	140	-6°	-6°	CN .. 1606 ..	
	C5-PCLNL-35060-16		16	C5	35	60	80	165	-6°	-6°		
	C6-PCLNL-45065-16		16	C6	45	65	81	190	-6°	-6°		
	C8-PCLNL-55080-16		16	C8	55	80	100	250	-6°	-6°		
	C6-PCLNL-45065-19		19	C6	45	65	1	190	-6°	-6°	CN .. 1906 ..	
	C8-PCLNL-55080-19		19	C8	55	80	100	250	-6°	-6°		
	C8-PCLNL-55080-25		25	C8	55	80	150	250	-6°	-6°	CN .. 2509 ..	

Dimensional drawing shows right-hand version. | Measured with master insert: CN .. 120408 / CN .. 160612 / CN .. 190612 / CN .. 250924 | Refer to the Walter online catalogue for more product information: [www.walter-tools.com](http://www.walter-tools.com) | Bodies and assembly parts are included in the scope of delivery

Assembly parts		CN .. 1204 .. C3-C4	CN .. 1204 .. C5-C6	CN .. 1204 .. C8	CN .. 1606 .. C4	CN .. 1606 .. C5-C6	CN .. 1606 .. C8	CN .. 1906 .. C6	CN .. 1906 .. C8	CN .. 2509 .. C8
	Shim	AP134-CN1216	AP134-CN1216	AP134-CN1216	AP135-CN1624	AP135-CN1624	AP135-CN1624	AP136-CN1924	AP136-CN1924	AP192-CN2524
	Lever	KN102	KN102	KN102	KN104	KN104	KN104	KN106	KN106	KN107
	Clamping screw Tightening torque	FS352 (SW 3) 5 Nm	FS352 (SW 3) 5 Nm	FS352 (SW 3) 5 Nm	FS354 (SW 3) 5 Nm	FS354 (SW 3) 5 Nm	FS354 (SW 3) 5 Nm	FS356 (SW 4) 10 Nm	FS356 (SW 4) 10 Nm	FS357 (SW 5) 14 Nm
	Shim pin	RS102	RS102	RS102	RS103	RS103	RS103	RS104	RS104	RS105
	Tapered assembly pin	MD101	MD101	MD101	MD102	MD102	MD102	MD102	MD102	MD103
	Cooling nozzle	FS1477	FS1476	FS1479	FS1477	FS1476	FS1479	FS1476	FS1479	FS1479
	Allen key	ISO2936-3 (SW 3)	ISO2936-3 (SW 3)	ISO2936-3 (SW 3)	ISO2936-3 (SW 3)	ISO2936-3 (SW 3)	ISO2936-3 (SW 3)	ISO2936-4 (SW 4)	ISO2936-4 (SW 4)	ISO2936-5 (SW 5)

Accessories		CN .. 1204 ..	CN .. 1606 ..	CN .. 1906 ..	CN .. 2509 ..
	Shim	AP134-CN1208	AP135-CN1616	AP136-CN1912	

## Turning tools – Rigid clamping

C...-DDHN...-P 

## Walter Turn

- Precision cooling
- Walter Capto™

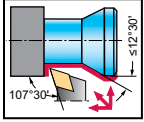

## Tool

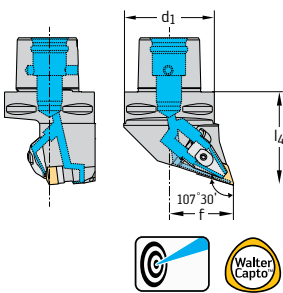

Designation		d <sub>1</sub>	f mm	l <sub>4</sub> mm	D <sub>min</sub> mm	D <sub>min2</sub> mm	γ	λ <sub>s</sub>	Type
C6-DDHNR-45065-15-P	15	C6	45	65	500	700	-6°	7°	DN .. 1506 ..
C6-DDHNL-45065-15-P	15	C6	45	65	500	700	-6°	-7°	DN .. 1506 ..

Walter Capto™ in acc. with ISO 26623

Dimensional drawing shows right-hand version. | Measured with master insert: DN .. 150608 | The maximum recommended coolant pressure is 150 bar (2175 psi) | Refer to the Walter online catalogue for more product information: [www.walter-tools.com](http://www.walter-tools.com) | Bodies and assembly parts are included in the scope of delivery

## Assembly parts

Type	d <sub>1</sub>	DN .. 1506 .. C6
	Shim	AP304-DN15
	Screw for shim Tightening torque	FS1461 (T15IP) 2,5 Nm
	Clamp	PK256
	Screw for clamp Tightening torque	FS1473 (T15IP) 3,9 Nm
	Pressure spring	FS2188
	Torx key	FS1465 (T15IP)

## Accessories

Type	DN .. 1506 ..
 (standard assembly parts) Clamp set	PK256-SET
	Shim for DN .. 1504 .. AP304-DN1504

## Turning tools – Rigid clamping

C...-DDJN 

## Walter Turn

– Walter Capto™

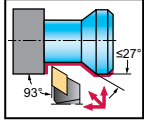

Tool	Designation		d <sub>1</sub>	f mm	l <sub>4</sub> mm	D <sub>min</sub> mm	D <sub>min2</sub> mm	γ	λ <sub>s</sub>	Type
	C4-DDJNR-27050-11	11	C4	27	50	60	140	-6°	-7°	DN .. 1104 ..
	C5-DDJNR-35060-11	11	C5	35	60	65	165	-6°	-7°	
	C6-DDJNR-45065-11	11	C6	45	65	81	190	-6°	-7°	
	C4-DDJNR-27055-15	15	C4	27	55	110	145	-6°	-7°	DN .. 1506 ..
	C5-DDJNR-35060-15	15	C5	35	60	110	165	-6°	-7°	
	C6-DDJNR-45065-15	15	C6	45	65	110	190	-6°	-7°	
	C8-DDJNR-55080-15	15	C8	55	80	110	250	-6°	-7°	
Walter Capto™ in acc. with ISO 26623	C4-DDJNL-27050-11	11	C4	27	50	60	140	-6°	-7°	DN .. 1104 ..
	C5-DDJNL-35060-11	11	C5	35	60	65	165	-6°	-7°	
	C6-DDJNL-45065-11	11	C6	45	65	81	190	-6°	-7°	
	C4-DDJNL-27055-15	15	C4	27	55	110	145	-6°	-7°	DN .. 1506 ..
	C5-DDJNL-35060-15	15	C5	35	60	110	165	-6°	-7°	
	C6-DDJNL-45065-15	15	C6	45	65	110	190	-6°	-7°	
	C8-DDJNL-55080-15	15	C8	55	80	110	250	-6°	-7°	

Dimensional drawing shows right-hand version. | Measured with master insert: DN .. 110408 / DN .. 150608 | Refer to the Walter online catalogue for more product information: [www.walter-tools.com](http://www.walter-tools.com) | Bodies and assembly parts are included in the scope of delivery

Assembly parts	Type d <sub>1</sub>	DN .. 1104 .. C4	DN .. 1104 .. C5-C6	DN .. 1506 .. C4	DN .. 1506 .. C5	DN .. 1506 .. C6	DN .. 1506 .. C8
	Shim	AP305-DN11	AP305-DN11	AP304-DN15	AP304-DN15	AP304-DN15	AP304-DN15
	Screw for shim Tightening torque	FS1462 (T9IP) 1,5 Nm	FS1462 (T9IP) 1,5 Nm	FS1461 (T15IP) 2,5 Nm	FS1461 (T15IP) 2,5 Nm	FS1461 (T15IP) 2,5 Nm	FS1461 (T15IP) 2,5 Nm
	Clamp	PK240	PK240	PK241	PK241	PK241	PK241
	Screw for clamp Tightening torque	FS1472 (T9IP) 1,7 Nm	FS1472 (T9IP) 1,7 Nm	FS1473 (T15IP) 3,9 Nm	FS1473 (T15IP) 3,9 Nm	FS1473 (T15IP) 3,9 Nm	FS1473 (T15IP) 3,9 Nm
	Pressure spring	FS1469	FS1469	FS1470	FS1470	FS1470	FS1470
	Pin	RS116	RS116	RS117	RS117	RS117	RS117
	Cooling nozzle	FS1477	FS1476	FS1477	FS1475	FS1476	FS1479
	Torx key	FS1466 (T9IP)	FS1466 (T9IP)	FS1465 (T15IP)	FS1465 (T15IP)	FS1465 (T15IP)	FS1465 (T15IP)

Accessories	Type	DN .. 1104 ..	DN .. 1506 ..
	(standard assembly parts) Clamp set	PK240-SET	PK241-SET
	Insert without hole Carbide clamp set		PK245-SET
	Insert without hole Carbide clamp set		PK254-SET
	Shim for DN .. 1504 ..		AP304-DN1504
	Shim for DN .. 1507 ..		AP412-DN1507

## Turning tools – Rigid clamping

C...-DDJN...-P 

## Walter Turn

- Precision cooling
- Walter Capto™

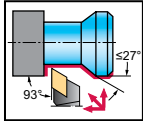

## Tool

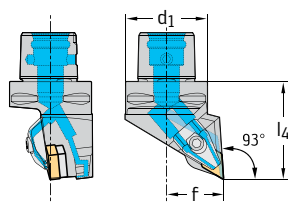

## Designation

 $d_1$ f  
mm $l_4$   
mm $D_{min}$   
mm $D_{min2}$   
mm $\gamma$  $\lambda_s$ 

Type

C4-DDJNR-27055-11-P

11

C4

27

55

500

500

-6°

-7°

DN .. 1104 ..

C4-DDJNR-27055-15-P

15

C4

27

55

500

500

-6°

-7°

DN .. 1506 ..

C5-DDJNR-35060-15-P

15

C5

35

60

500

600

-6°

-7°

C6-DDJNR-45065-15-P

15

C6

45

65

500

600

-6°

-7°

C8-DDJNR-55080-15-P

15

C8

55

80

1.100

700

-6°

-7°

C4-DDJNL-27055-11-P

11

C4

27

55

500

500

-6°

-7°

DN .. 1104 ..

C4-DDJNL-27055-15-P

15

C4

27

55

500

500

-6°

-7°

DN .. 1506 ..

C5-DDJNL-35060-15-P

15

C5

35

60

500

600

-6°

-7°

C6-DDJNL-45065-15-P

15

C6

45

65

500

600

-6°

-7°

C8-DDJNL-55080-15-P

15

C8

55

80

1.100

700

-6°

-7°

Walter Capto™ in acc. with ISO 26623

Dimensional drawing shows right-hand version. | Measured with master insert: DN .. 110408 / DN .. 150608 | The maximum recommended coolant pressure is 150 bar (2175 psi) | Refer to the Walter online catalogue for more product information: [www.walter-tools.com](http://www.walter-tools.com) | Bodies and assembly parts are included in the scope of delivery

## Assembly parts

	Type $d_1$	DN .. 1104 .. C4	DN .. 1506 .. C4-C8
	Shim	AP305-DN11	AP304-DN15
	Screw for shim Tightening torque	FS1462 (T9IP) 1,5 Nm	FS1461 (T15IP) 2,5 Nm
	Clamp	PK255	PK256
	Screw for clamp Tightening torque	FS1473 (T15IP) 3,9 Nm	FS1473 (T15IP) 3,9 Nm
	Pressure spring	FS2188	FS2188
	Torx key	FS1465 (T15IP)	FS1465 (T15IP)

## Accessories

	Type	DN .. 1104 ..	DN .. 1506 ..
	(standard assembly parts) Clamp set	PK255-SET	PK256-SET
	Shim for DN .. 1504 ..		AP304-DN1504

## Turning tools – Lever clamping

C...-PDJN 

## Walter Turn

– Walter Capto™

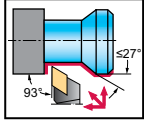

## Tool

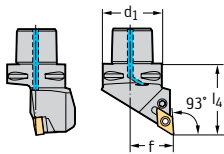

Walter Capto™ in acc. with ISO 26623

Designation		d <sub>1</sub>	f mm	l <sub>4</sub> mm	D <sub>min</sub> mm	D <sub>min2</sub> mm	γ	λ <sub>s</sub>	Type	
C3-PDJNR-22045-11		11	C3	22	45	80	116	-6°	-7°	DN .. 1104 ..
C4-PDJNR-27050-11		11	C4	27	50	80	140	-6°	-7°	
C5-PDJNR-35060-11		11	C5	35	60	80	165	-6°	-7°	
C4-PDJNR-27050-15		15	C4	27	50	80	140	-6°	-7°	DN .. 1506 ..
C5-PDJNR-35060-15		15	C5	35	60	80	165	-6°	-7°	
C6-PDJNR-45065-15		15	C6	45	65	80	190	-6°	-7°	
C3-PDJNL-22045-11		11	C3	22	45	80	116	-6°	-7°	DN .. 1104 ..
C4-PDJNL-27050-11		11	C4	27	50	80	140	-6°	-7°	
C5-PDJNL-35060-11		11	C5	35	60	80	165	-6°	-7°	
C4-PDJNL-27050-15		15	C4	27	50	80	140	-6°	-7°	DN .. 1506 ..
C5-PDJNL-35060-15		15	C5	35	60	80	165	-6°	-7°	
C6-PDJNL-45065-15		15	C6	45	65	80	190	-6°	-7°	

Dimensional drawing shows right-hand version. | Measured with master insert: DN .. 110408 / DN .. 150608 | Refer to the Walter online catalogue for more product information: [www.walter-tools.com](http://www.walter-tools.com) | Bodies and assembly parts are included in the scope of delivery

## Assembly parts

Type d <sub>1</sub>	DN .. 1104 .. C3–C4	DN .. 1104 .. C5	DN .. 1506 .. C4	DN .. 1506 .. C5–C6	
	Shim	AP171-DN1112	AP171-DN1112	AP145-DN1516	AP145-DN1516
	Lever	KN119	KN119	KN103	KN103
	Clamping screw Tightening torque	FS351 (SW 2,5) 2 Nm	FS351 (SW 2,5) 2 Nm	FS355 (SW 3) 5 Nm	FS355 (SW 3) 5 Nm
	Shim pin	RS101	RS101	RS102	RS102
	Tapered assembly pin	MD101	MD101	MD101	MD101
	Cooling nozzle	FS1477	FS1476	FS1477	FS1476
	Allen key	ISO2936-2,5 (SW 2,5)	ISO2936-2,5 (SW 2,5)	ISO2936-3 (SW 3)	ISO2936-3 (SW 3)

## Accessories

Type	DN .. 1104 ..	DN .. 1506 ..	
	Shim	AP171-DN1108	AP145-DN1508
	Shim for DN .. 1504 ..		AP357-DN1508
	Shim for DN .. 1504 ..		AP357-DN1516

## Turning tools – Rigid clamping

C...-DDUN 

## Walter Turn

– Walter Capto™

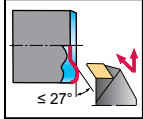

## Tool

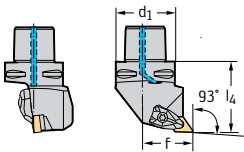

Walter Capto™ in acc. with ISO 26623

Designation		d <sub>1</sub>	f mm	l <sub>4</sub> mm	D <sub>min</sub> mm	D <sub>min2</sub> mm	γ	λ <sub>s</sub>	Type
C4-DDUNR-27050-15	15	C4	27	50	110	140	-6°	-7°	DN .. 1506 ..
C5-DDUNR-35060-15	15	C5	35	60	110	165	-6°	-7°	
C6-DDUNR-45065-15	15	C6	45	65	110	190	-6°	-7°	
C8-DDUNR-55080-15	15	C8	55	80	110	250	-6°	-7°	
C4-DDUNL-27050-15	15	C4	27	50	110	140	-6°	-7°	DN .. 1506 ..
C5-DDUNL-35060-15	15	C5	35	60	110	165	-6°	-7°	
C6-DDUNL-45065-15	15	C6	45	65	110	190	-6°	-7°	
C8-DDUNL-55080-15	15	C8	55	80	110	250	-6°	-7°	

Dimensional drawing shows right-hand version. | Measured with master insert: DN .. 150608 | Refer to the Walter online catalogue for more product information: [www.walter-tools.com](http://www.walter-tools.com) | Bodies and assembly parts are included in the scope of delivery

## Assembly parts

	Type d <sub>1</sub>	DN .. 1506 .. C4	DN .. 1506 .. C5-C6	DN .. 1506 .. C8
	Shim	AP304-DN15	AP304-DN15	AP304-DN15
	Screw for shim Tightening torque	FS1461 (T15IP) 2,5 Nm	FS1461 (T15IP) 2,5 Nm	FS1461 (T15IP) 2,5 Nm
	Clamp	PK241	PK241	PK241
	Screw for clamp Tightening torque	FS1473 (T15IP) 3,9 Nm	FS1473 (T15IP) 3,9 Nm	FS1473 (T15IP) 3,9 Nm
	Pressure spring	FS1471	FS1471	FS1471
	Pin	RS117	RS117	RS117
	Cooling nozzle	FS1477	FS1476	FS1479
	Torx key	FS1465 (T15IP)	FS1465 (T15IP)	FS1465 (T15IP)

## Accessories

	Type	DN .. 1506 ..
	(standard assembly parts) Clamp set	PK241-SET
	Insert without hole Carbide clamp set	PK245-SET
	Insert without hole Carbide clamp set	PK254-SET
	Shim for DN .. 1504 ..	AP304-DN1504
	Shim for DN .. 1507 ..	AP412-DN1507





## Turning tools – Rigid clamping

C...-DDUN...-P mm

### Walter Turn

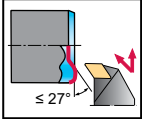

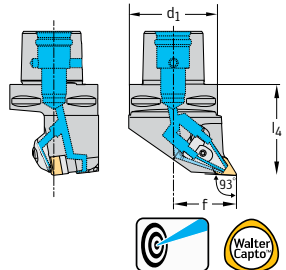

- Precision cooling
- Walter Capto™



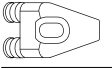
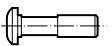

Tool		Designation		$d_1$	f mm	$l_4$ mm	$D_{min}$ mm	$D_{min2}$ mm	$\gamma$	$\lambda_s$	Type
		C6-DDUNR-45065-15-P	15	C6	45	65	500	600	-6,5°	-6°	DN .. 1506 ..
		C6-DDUNL-45065-15-P	15	C6	45	65	500	600	-6,5°	-6°	DN .. 1506 ..

Walter Capto™ in acc. with ISO 26623

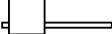
Dimensional drawing shows right-hand version. | Measured with master insert: DN .. 150608 | The maximum recommended coolant pressure is 150 bar (2175 psi) | Refer to the Walter online catalogue for more product information: [www.walter-tools.com](http://www.walter-tools.com) | Bodies and assembly parts are included in the scope of delivery

Assembly parts		Type	DN .. 1506 .. C6
	Shim		AP304-DN15
	Screw for shim Tightening torque		FS1461 (T15IP) 2,5 Nm
	Clamp		PK256
	Screw for clamp Tightening torque		FS1473 (T15IP) 3,9 Nm
	Pressure spring		FS2188
	Torx key		FS1465 (T15IP)

Accessories		Type	DN .. 1506 ..
	(standard assembly parts) Clamp set		PK256-SET
	Shim for DN .. 1504 ..		AP304-DN1504

## Turning tools – Rigid clamping

C...-DSRN 

## Walter Turn

– Walter Capto™

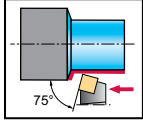

## Tool

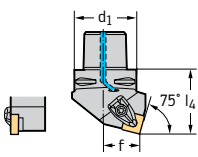





Walter Capto™ in acc. with ISO 26623

Designation		d <sub>1</sub>	f mm	l <sub>4</sub> mm	D <sub>min</sub> mm	D <sub>min2</sub> mm	γ	λ <sub>s</sub>	Type
C4-DSRNR-22050-12	12	C4	22	50		140	-6°	-6°	SN .. 1204 ..
C5-DSRNR-27060-12	12	C5	27	60		165	-6°	-6°	
C6-DSRNR-35065-12	12	C6	35	65		190	-6°	-6°	
C5-DSRNR-27060-15	15	C5	27	60		165	-6°	-6°	SN .. 1506 ..
C6-DSRNR-35065-15	15	C6	35	65		190	-6°	-6°	
C6-DSRNR-35065-19	19	C6	35	65		190	-6°	-6°	SN .. 1906 ..
C8-DSRNR-45080-19	19	C8	45	80		250	-6°	-6°	
C8-DSRNR-45080-25	25	C8	45	80		250	-6°	-6°	SN .. 2507 ..
C4-DSRNL-22050-12	12	C4	22	50		140	-6°	-6°	SN .. 1204 ..
C5-DSRNL-27060-12	12	C5	27	60		165	-6°	-6°	
C6-DSRNL-35065-12	12	C6	35	65		190	-6°	-6°	
C5-DSRNL-27060-15	15	C5	27	60		165	-6°	-6°	SN .. 1506 ..
C6-DSRNL-35065-15	15	C6	35	65		190	-6°	-6°	
C6-DSRNL-35065-19	19	C6	35	65		190	-6°	-6°	SN .. 1906 ..
C8-DSRNL-45080-19	19	C8	45	80		250	-6°	-6°	
C8-DSRNL-45080-25	25	C8	45	80		250	-6°	-6°	SN .. 2507 ..

Dimensional drawing shows right-hand version. | Measured with master insert: SN .. 120408 / SN .. 150612 / SN .. 190612 / SN .. 250724 | Refer to the Walter online catalogue for more product information: [www.walter-tools.com](http://www.walter-tools.com) | Bodies and assembly parts are included in the scope of delivery

## Assembly parts

Type d <sub>1</sub>	SN .. 1204 .. C4–C6	SN .. 1506 .. C5–C6	SN .. 1906 .. C6–C8	SN .. 2507 .. C8	
	Shim	AP308-SN12	AP309-SN15	AP310-SN19	AP351-SN25
	Screw for shim Tightening torque	FS1461 (T15IP) 2,5 Nm	FS1463 (T20IP) 5 Nm	FS1463 (T20IP) 5 Nm	FS1589 (T25IP) 9,5 Nm
	Clamp	PK241	PK242	PK243	PK301
	Screw for clamp Tightening torque	FS1473 (T15IP) 3,9 Nm	FS1474 (T20IP) 6,4 Nm	FS1474 (T20IP) 6,4 Nm	FS1591 (T25IP) 9,5 Nm
	Pressure spring	FS1470	FS1471	FS1471	FS1471
	Pin	RS117	RS117	RS117	RS117
	Cooling nozzle	FS1475	FS1475	FS1475	FS1475
	Torx key	FS1465 (T15IP)			
	Allen key		FS1464 (T20IP)	FS1464 (T20IP)	FS1592 (T25IP)

Accessories					
	Type	SN .. 1204 ..	SN .. 1506 ..	SN .. 1906 ..	SN .. 2507 ..
	(standard assembly parts) Clamp set	PK241-SET	PK242-SET	PK243-SET	PK301-SET
	Insert with hole Carbide clamp set	PK245-SET	PK246-SET		
	Insert with hole Carbide clamp set	PK254-SET			
	Shim for SN .. 1207 ..	AP413-SN1207			
	Shim for SN .. 2509 ..				AP351-SN2509

## Turning tools – Lever clamping

C...-PSRN 

## Walter Turn

– Walter Capto™

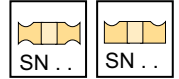
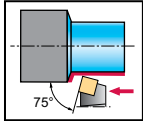

## Tool

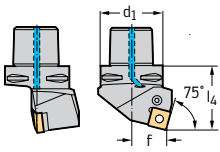

Designation		d <sub>1</sub>	f mm	l <sub>4</sub> mm	D <sub>min</sub> mm	D <sub>min2</sub> mm	γ	λ <sub>s</sub>	Type
C6-PSRNR-35065-19		19	C6	35	65		-6°	-6°	SN .. 1906 ..
C8-PSRNR-45080-19		19	C8	45	80		-6°	-6°	
C8-PSRNR-45080-25		25	C8	45	80		-6°	-6°	SN .. 2507 ..
C6-PSRNL-35065-19		19	C6	35	65		-6°	-6°	SN .. 1906 ..
C8-PSRNL-45080-19		19	C8	45	80		-6°	-6°	
C8-PSRNL-45080-25		25	C8	45	80		-6°	-6°	SN .. 2507 ..

Walter Capto™ in acc. with ISO 26623

Dimensional drawing shows right-hand version. | Measured with master insert: SN .. 190612 / SN .. 250724 | Refer to the Walter online catalogue for more product information: [www.walter-tools.com](http://www.walter-tools.com) | Bodies and assembly parts are included in the scope of delivery

## Assembly parts

Type	SN .. 1906 .. C6	SN .. 1906 .. C8	SN .. 2507 .. C8
Shim	AP143-SN1924	AP143-SN1924	AP144-SN2524
Lever	KN106	KN106	KN107
Clamping screw Tightening torque	FS356 (SW 4) 10 Nm	FS356 (SW 4) 10 Nm	FS357 (SW 5) 14 Nm
Shim pin	RS104	RS104	RS105
Tapered assembly pin	MD102	MD102	MD103
Allen key	ISO2936-4 (SW 4)	ISO2936-4 (SW 4)	ISO2936-5 (SW 5)
Cooling nozzle	FS1476	FS1479	FS1479

## Accessories

Type	SN .. 1906 ..	SN .. 2507 ..
Shim	AP143-SN1912	AP191-SN250924

## Turning tools – Rigid clamping

C...-DSKN 

## Walter Turn

– Walter Capto™

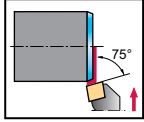

Tool	Designation		d <sub>1</sub>	f mm	l <sub>4</sub> mm	D <sub>min</sub> mm	D <sub>min2</sub> mm	γ	λ <sub>s</sub>	Type
 Walter Capto™ in acc. with ISO 26623	C4-DSKNR-27050-12	12	C4	27	50	110		-6°	-6°	SN .. 1204 ..
	C5-DSKNR-35060-12	12	C5	35	60	110		-6°	-6°	
	C6-DSKNR-45065-12	12	C6	45	65	110		-6°	-6°	
	C6-DSKNR-45065-19	19	C6	45	65	125		-6°	-6°	SN .. 1906 ..
	C8-DSKNR-55080-19	19	C8	55	80	125		-6°	-6°	
	C4-DSKNL-27050-12	12	C4	27	50	110		-6°	-6°	SN .. 1204 ..
	C5-DSKNL-35060-12	12	C5	35	60	110		-6°	-6°	
	C6-DSKNL-45065-12	12	C6	45	65	110		-6°	-6°	
C6-DSKNL-45065-19	19	C6	45	65	125		-6°	-6°	SN .. 1906 ..	
C8-DSKNL-55080-19	19	C8	55	80	125		-6°	-6°		

Dimensional drawing shows right-hand version. | Measured with master insert: SN .. 120408 / SN .. 190612 | Refer to the Walter online catalogue for more product information: [www.walter-tools.com](http://www.walter-tools.com) | Bodies and assembly parts are included in the scope of delivery

Assembly parts	Type d <sub>1</sub>	SN .. 1204 .. C4	SN .. 1204 .. C5–C6	SN .. 1906 .. C6	SN .. 1906 .. C8
	Shim	AP308-SN12	AP308-SN12	AP310-SN19	AP310-SN19
	Screw for shim Tightening torque	FS1461 (T15IP) 2,5 Nm	FS1461 (T15IP) 2,5 Nm	FS1463 (T20IP) 5 Nm	FS1463 (T20IP) 5 Nm
	Clamp	PK241	PK241	PK243	PK243
	Screw for clamp Tightening torque	FS1473 (T15IP) 3,9 Nm	FS1473 (T15IP) 3,9 Nm	FS1474 (T20IP) 6,4 Nm	FS1474 (T20IP) 6,4 Nm
	Pressure spring	FS1470	FS1470	FS1471	FS1471
	Pin	RS117	RS117	RS117	RS117
	Cooling nozzle	FS1477	FS1476	FS1476	FS1479
	Torx key	FS1465 (T15IP)	FS1465 (T15IP)		
	Allen key			FS1464 (T20IP)	FS1464 (T20IP)

Accessories	Type	SN .. 1204 ..	SN .. 1906 ..
	(standard assembly parts) Clamp set	PK241-SET	PK243-SET
	Insert without hole Carbide clamp set	PK245-SET	
	Insert without hole Carbide clamp set	PK254-SET	
	Shim for SN .. 1207 ..	AP413-SN1207	

## Turning tools – Lever clamping

C...-PSKN 

## Walter Turn

– Walter Capto™

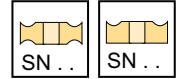
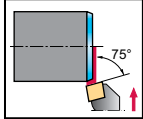

## Tool

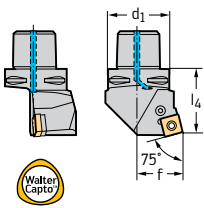





Designation		$d_1$	f mm	$l_4$ mm	$D_{min}$ mm	$D_{min2}$ mm	$\gamma$	$\lambda_s$	Type	
C6-PSKNR-45065-15		15	C6	45	65	81	190	-6°	-6°	SN .. 1506 ..
C6-PSKNR-45065-19		19	C6	45	65	81	190	-6°	-6°	SN .. 1906 ..
C8-PSKNR-55080-19		19	C8	55	80	100	250	-6°	-6°	
C6-PSKNL-45065-15		15	C6	45	65	81	190	-6°	-6°	SN .. 1506 ..
C6-PSKNL-45065-19		19	C6	45	65	81	190	-6°	-6°	SN .. 1906 ..
C8-PSKNL-55080-19		19	C8	55	80	100	250	-6°	-6°	

Walter Capto™ in acc. with ISO 26623

Dimensional drawing shows right-hand version. | Measured with master insert: SN .. 150612 / SN .. 190612 | Refer to the Walter online catalogue for more product information: [www.walter-tools.com](http://www.walter-tools.com) | Bodies and assembly parts are included in the scope of delivery

## Assembly parts

	Type $d_1$	SN .. 1506 .. C6	SN .. 1906 .. C6	SN .. 1906 .. C8
	Shim	AP142-SN1524	AP143-SN1924	AP143-SN1924
	Lever	KN104	KN106	KN106
	Clamping screw Tightening torque	FS354 (SW 3) 5 Nm	FS356 (SW 4) 10 Nm	FS356 (SW 4) 10 Nm
	Shim pin	RS103	RS104	RS104
	Tapered assembly pin	MD102	MD102	MD102
	Cooling nozzle	FS1476	FS1476	FS1479
	Allen key	ISO2936-3 (SW 3)	ISO2936-4 (SW 4)	ISO2936-4 (SW 4)

## Accessories

	Type	SN .. 1506 ..	SN .. 1906 ..
	Shim	AP142-SN1516	AP143-SN1912

## Turning tools – Rigid clamping

C...-DSSN 

## Walter Turn

– Walter Capto™

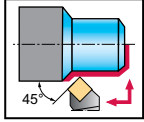

Tool	Designation		d <sub>1</sub>	f mm	f <sub>1</sub> mm	l <sub>4</sub> mm	l <sub>20</sub> mm	D <sub>min</sub> mm	D <sub>min2</sub> mm	γ	λ <sub>s</sub>	Type
 Walter Capto™ in acc. with ISO 26623	C4-DSSNR-27042-12	12	C4	27	19	42	50	110	140	-8°	0°	SN .. 1204 ..
	C5-DSSNR-35052-12	12	C5	35	27	52	60	110	165	-8°	0°	
	C6-DSSNR-45056-12	12	C6	45	37	56	64	110	190	-8°	0°	
	C4-DSSNR-27045-15	15	C4	27	17	45	55	125	145	-8°	0°	SN .. 1506 ..
	C5-DSSNR-35050-15	15	C5	35	25	50	60	125	165	-8°	0°	
	C6-DSSNR-45054-15	15	C6	45	35	54	60	125	190	-8°	0°	
	C6-DSSNR-45052-19	19	C6	45	33	52	64	125	190	-8°	0°	SN .. 1906 ..
	C4-DSSNL-27042-12	12	C4	27	19	42	50	110	140	-8°	0°	SN .. 1204 ..
	C5-DSSNL-35052-12	12	C5	35	27	52	60	110	165	-8°	0°	
	C6-DSSNL-45056-12	12	C6	45	37	56	64	110	190	-8°	0°	
	C4-DSSNL-27045-15	15	C4	27	17	45	55	125	145	-8°	0°	SN .. 1506 ..
	C5-DSSNL-35050-15	15	C5	35	25	50	60	125	165	-8°	0°	
	C6-DSSNL-45054-15	15	C6	45	35	54	60	125	190	-8°	0°	
	C6-DSSNL-45052-19	19	C6	45	33	52	64	125	190	-8°	0°	SN .. 1906 ..

Dimensional drawing shows right-hand version. | Measured with master insert: SN .. 120408 / SN .. 150612 / SN .. 190612 | Refer to the Walter online catalogue for more product information: [www.walter-tools.com](http://www.walter-tools.com) | Bodies and assembly parts are included in the scope of delivery

Assembly parts	Type	SN .. 1204 ..	SN .. 1204 ..	SN .. 1204 ..	SN .. 1506 ..	SN .. 1506 ..	SN .. 1506 ..	SN .. 1906 ..
		d <sub>1</sub>	C4	C5	C6	C4	C5	C6
	Shim	AP308-SN12	AP308-SN12	AP308-SN12	AP309-SN15	AP309-SN15	AP309-SN15	AP310-SN19
	Screw for shim Tightening torque	FS1461 (T15IP) 2,5 Nm	FS1461 (T15IP) 2,5 Nm	FS1461 (T15IP) 2,5 Nm	FS1463 (T20IP) 5 Nm	FS1463 (T20IP) 5 Nm	FS1463 (T20IP) 5 Nm	FS1463 (T20IP) 5 Nm
	Clamp	PK241	PK241	PK241	PK242	PK242	PK242	PK243
	Screw for clamp Tightening torque	FS1473 (T15IP) 3,9 Nm	FS1473 (T15IP) 3,9 Nm	FS1473 (T15IP) 3,9 Nm	FS1474 (T20IP) 6,4 Nm	FS1474 (T20IP) 6,4 Nm	FS1474 (T20IP) 6,4 Nm	FS1474 (T20IP) 6,4 Nm
	Pressure spring	FS1470	FS1470	FS1470	FS1471	FS1471	FS1471	FS1471
	Pin	RS117	RS117	RS117	RS117	RS117	RS117	RS117
	Cooling nozzle	FS1477	FS1476	FS1475	FS1477	FS1476	FS1475	FS1476
	Torx key	FS1465 (T15IP)	FS1465 (T15IP)	FS1465 (T15IP)				
	Allen key				FS1464 (T20IP)	FS1464 (T20IP)	FS1464 (T20IP)	FS1464 (T20IP)

Accessories	Type	SN .. 1204 ..	SN .. 1506 ..	SN .. 1906 ..
		(standard assembly parts) Clamp set	PK241-SET	PK242-SET
Insert with hole Carbide clamp set	PK245-SET	PK246-SET		
Insert with hole Carbide clamp set	PK254-SET			
Shim for SN .. 1207 ..	AP413-SN1207			

## Turning tools – Rigid clamping

C...-DSDN 

## Walter Turn



– Walter Capto™

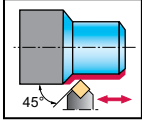

Tool	Designation		d <sub>1</sub>	f mm	l <sub>4</sub> mm	D <sub>min</sub> mm	D <sub>min2</sub> mm	γ	λ <sub>s</sub>	Type
	C4-DSDNN-00050-12	12	C4	0	50		140	-6°	-6°	SN .. 1204 ..
	C5-DSDNN-00060-12	12	C5	0	60		165	-6°	-6°	
	C6-DSDNN-00065-12	12	C6	0	65		190	-6°	-6°	
	C6-DSDNN-00070-19	19	C6	1	70		195	-6°	-6°	SN .. 1906 ..
	C8-DSDNN-00080-25	25	C8	1	80		250	-6°	-6°	SN .. 2507 ..

Walter Capto™ in acc. with ISO 26623

Measured with master insert: SN .. 120408 / SN .. 190612 / SN .. 250724 | Refer to the Walter online catalogue for more product information: [www.walter-tools.com](http://www.walter-tools.com) | Bodies and assembly parts are included in the scope of delivery

Assembly parts	Type d <sub>1</sub>	SN .. 1204 .. C4	SN .. 1204 .. C5–C6	SN .. 1906 .. C6	SN .. 2507 .. C8
	Shim	AP308-SN12	AP308-SN12	AP310-SN19	AP351-SN25
	Screw for shim Tightening torque	FS1461 (T15IP) 2,5 Nm	FS1461 (T15IP) 2,5 Nm	FS1463 (T20IP) 5 Nm	FS1589 (T25IP) 9,5 Nm
	Clamp	PK241	PK241	PK243	PK301
	Screw for clamp Tightening torque	FS1473 (T15IP) 3,9 Nm	FS1473 (T15IP) 3,9 Nm	FS1474 (T20IP) 6,4 Nm	FS1591 (T25IP) 9,5 Nm
	Pressure spring	FS1470	FS1470	FS1471	FS1471
	Pin	RS117	RS117	RS117	RS117
	Cooling nozzle	FS1477	FS1475	FS1475	FS1475
	Torx key	FS1465 (T15IP)	FS1465 (T15IP)		
	Allen key			FS1464 (T20IP)	FS1592 (T25IP)

Accessories	Type	SN .. 1204 ..	SN .. 1906 ..	SN .. 2507 ..
	(standard assembly parts) Clamp set	PK241-SET	PK243-SET	PK301-SET
	Insert without hole Carbide clamp set	PK245-SET		
	Insert without hole Carbide clamp set	PK254-SET		
	Shim for SN .. 1207 ..	AP413-SN1207		
	Shim for SN .. 2509 ..			AP351-SN2509



# Turning tools – Wedge clamping

C...-MTJN mm

## Walter Turn

– Walter Capto™

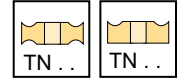
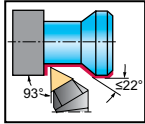

Tool	Designation		d <sub>1</sub>	f mm	l <sub>4</sub> mm	D <sub>min</sub> mm	D <sub>min2</sub> mm	γ	λ <sub>s</sub>	Type	
  Walter Capto™ in acc. with ISO 26623	C4-MTJNR-27050-16		16	C4	27	50			-6°	-6°	TN .. 1604 ..
	C5-MTJNR-35060-16		16	C5	35	60			-6°	-6°	
	C4-MTJNR-27050-22		22	C4	27	50			-6°	-6°	TN .. 2204 ..
	C5-MTJNR-35060-22		22	C5	35	60			-6°	-6°	
	C6-MTJNR-45065-22		22	C6	45	65			-6°	-6°	
	C4-MTJNL-27050-16		16	C4	27	50			-6°	-6°	TN .. 1604 ..
C5-MTJNL-35060-16		16	C5	35	60			-6°	-6°		
C4-MTJNL-27050-22		22	C4	27	50			-6°	-6°	TN .. 2204 ..	
C5-MTJNL-35060-22		22	C5	35	60			-6°	-6°		
C6-MTJNL-45065-22		22	C6	45	65			-6°	-6°		

Dimensional drawing shows right-hand version. | Measured with master insert: TN .. 160408 / TN .. 220408 | Refer to the Walter online catalogue for more product information: [www.walter-tools.com](http://www.walter-tools.com) | Bodies and assembly parts are included in the scope of delivery

Assembly parts	Type d <sub>1</sub>	TN .. 1604 .. C4	TN .. 1604 .. C5	TN .. 2204 .. C4	TN .. 2204 .. C5-C6
	Shim	AP147	AP147	AP148	AP148
	Pin	RS106	RS106	RS107	RS107
	Clamping wedge set	FK303	FK303	FK304	FK304
	Allen key			ISO2936-3 (SW 3)	ISO2936-3 (SW 3)
	Allen key	ISO2936-2,5 (SW 2,5)	ISO2936-2,5 (SW 2,5)		
	Cooling nozzle		FS1476	FS1477	FS1476
	Clamping screw Tightening torque	FS358 (SW 3) 5 Nm	FS358 (SW 3) 5 Nm	FS358 (SW 3) 5 Nm	FS358 (SW 3) 5 Nm
	Cooling nozzle	FS1018			

Accessories	Type	TN .. 1604 ..	TN .. 2204 ..
	Shim		AP149

## Turning tools – Rigid clamping

C...-DTGN...-P 

## Walter Turn

- Precision cooling
- Walter Capto™

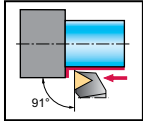

## Tool

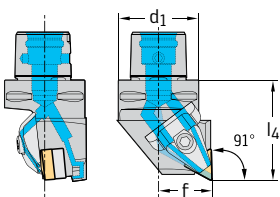

Walter Capto™ in acc. with ISO 26623

Designation		d <sub>1</sub>	f mm	l <sub>4</sub> mm	D <sub>min</sub> mm	D <sub>min2</sub> mm	γ	λ <sub>s</sub>	Type
C4-DTGNR-27050-16-P	16	C4	27	50	600	1.400	-6°	-6°	TN .. 1604 ..
C4-DTGNL-27050-16-P	16	C4	27	50	600	1.400	-6°	-6°	TN .. 1604 ..

Dimensional drawing shows right-hand version. | Measured with master insert: TN .. 160408 | The maximum recommended coolant pressure is 150 bar (2175 psi) | Refer to the Walter online catalogue for more product information: [www.walter-tools.com](http://www.walter-tools.com) | Bodies and assembly parts are included in the scope of delivery

## Assembly parts

Type	d <sub>1</sub>	TN .. 1604 ..
	Shim	AP321-TN16
	Screw for shim Tightening torque	FS1462 (T9IP) 1,5 Nm
	Clamp	PK255
	Screw for clamp Tightening torque	FS1473 (T15IP) 3,9 Nm
	Pressure spring	FS2188
	Torx key	FS1465 (T15IP)

## Accessories

Type	TN .. 1604 ..
 (standard assembly parts) Clamp set	PK255-SET

## Turning tools – Rigid clamping

C...-DVJN 

## Walter Turn

– Walter Capto™

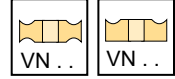
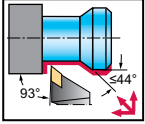

## Tool

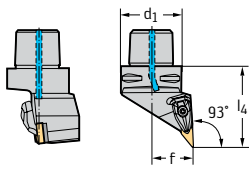

Walter Capto™ in acc. with ISO 26623

Designation		$d_1$	f mm	$l_4$ mm	$D_{min}$ mm	$D_{min2}$ mm	$\gamma$	$\lambda_s$	Type
C4-DVJNR-27062-16	16	C4	27	62	60	152	-4°	-13°	VN .. 1604 ..
C5-DVJNR-35065-16	16	C5	35	65	65	170	-4°	-13°	
C6-DVJNR-45065-16	16	C6	45	65	81	190	-4°	-13°	
C8-DVJNR-55080-16	16	C8	55	80	100	250	-4°	-13°	
C4-DVJNL-27062-16	16	C4	27	62	60	152	-4°	-13°	VN .. 1604 ..
C5-DVJNL-35065-16	16	C5	35	65	65	170	-4°	-13°	
C6-DVJNL-45065-16	16	C6	45	65	81	190	-4°	-13°	
C8-DVJNL-55080-16	16	C8	55	80	100	250	-4°	-13°	

Dimensional drawing shows right-hand version. | Measured with master insert: VN .. 160408 | Refer to the Walter online catalogue for more product information: [www.walter-tools.com](http://www.walter-tools.com) | Bodies and assembly parts are included in the scope of delivery

## Assembly parts

Type	$d_1$	VN .. 1604 .. C4	VN .. 1604 .. C5–C6	VN .. 1604 .. C8
	Shim	AP312-VN16	AP312-VN16	AP312-VN16
	Screw for shim Tightening torque	FS1467 (T15IP) 3 Nm	FS1467 (T15IP) 3 Nm	FS1467 (T15IP) 3 Nm
	Clamp	PK244	PK244	PK244
	Screw for clamp Tightening torque	FS1473 (T15IP) 3,9 Nm	FS1473 (T15IP) 3,9 Nm	FS1473 (T15IP) 3,9 Nm
	Pressure spring	FS1470	FS1470	FS1470
	Pin	RS117	RS117	RS117
	Cooling nozzle	FS1477	FS1476	FS1479
	Torx key	FS1465 (T15IP)	FS1465 (T15IP)	FS1465 (T15IP)

## Accessories

Type	VN .. 1604 ..
 (standard assembly parts) Clamp set	PK244-SET

## Turning tools - Rigid clamping

C...-DVJN...-P 

## Walter Turn

- Precision cooling
- Walter Capto™

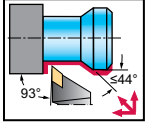

## Tool

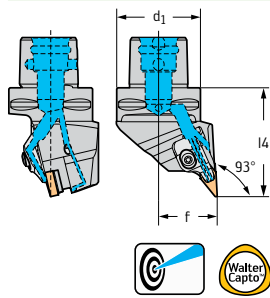

Designation		$d_1$	f mm	$l_4$ mm	$D_{min}$ mm	$D_{min2}$ mm	$\gamma$	$\lambda_s$	Type
C4-DVJNR-27062-16-P	16	C4	27	62	500	125	-4°	-13°	VN .. 1604 ..
C5-DVJNR-35065-16-P	16	C5	35	65	600	150	-4°	-13°	
C6-DVJNR-45065-16-P	16	C6	45	65	700	150	-4°	-13°	
C4-DVJNL-27062-16-P	16	C4	27	62	500	125	-4°	-13°	VN .. 1604 ..
C5-DVJNL-35065-16-P	16	C5	35	65	600	150	-4°	-13°	
C6-DVJNL-45065-16-P	16	C6	45	65	700	150	-4°	-13°	

Walter Capto™ in acc. with ISO 26623

Dimensional drawing shows right-hand version. | Measured with master insert: VN .. 160408 | The maximum recommended coolant pressure is 150 bar (2175 psi) | Refer to the Walter online catalogue for more product information: [www.walter-tools.com](http://www.walter-tools.com) | Bodies and assembly parts are included in the scope of delivery

## Assembly parts

	Type $d_1$	VN .. 1604 .. C4-C6
	Shim	AP312-VN16
	Screw for shim Tightening torque	FS1467 (T15IP) 3 Nm
	Right clamp	PK261R
	Left clamp	PK261L
	Screw for clamp Tightening torque	FS1473 (T15IP) 3,9 Nm
	Pressure spring	FS2188
	Torx key	FS1465 (T15IP)

## Accessories

	Type	VN .. 1604 ..
	Right clamp set	PK261R-SET
	Left clamp set	PK261L-SET

## Turning tools – Rigid clamping

C...-DWLN 

## Walter Turn

– Walter Capto™

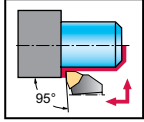

## Tool

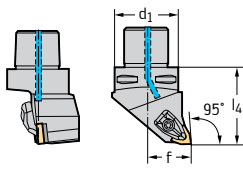

Walter Capto™ in acc. with ISO 26623

Designation		d <sub>1</sub>	f mm	l <sub>4</sub> mm	D <sub>min</sub> mm	D <sub>min2</sub> mm	γ	λ <sub>s</sub>	Type	
C4-DWLN-27050-06		6	C4	27	50	60	140	-6°	-6°	WN .. 0604 ..
C4-DWLN-27050-08		8	C4	27	50	110	140	-6°	-6°	WN .. 0804 ..
C5-DWLN-35060-08		8	C5	35	60	110	165	-6°	-6°	WN .. 1006 ..
C6-DWLN-45065-08		8	C6	45	65	110	190	-6°	-6°	
C5-DWLN-35060-10		10	C5	35	60	115	170	-6°	-6°	WN .. 1006 ..
C6-DWLN-45065-10		10	C6	45	65	115	195	-6°	-6°	
C4-DWLN-27050-06		6	C4	27	50	60	140	-6°	-6°	WN .. 0604 ..
C4-DWLN-27050-08		8	C4	27	50	110	140	-6°	-6°	WN .. 0804 ..
C5-DWLN-35060-08		8	C5	35	60	110	165	-6°	-6°	WN .. 1006 ..
C6-DWLN-45065-08		8	C6	45	65	110	190	-6°	-6°	
C5-DWLN-35060-10		10	C5	35	60	115	170	-6°	-6°	WN .. 1006 ..
C6-DWLN-45065-10		10	C6	45	65	115	195	-6°	-6°	

Dimensional drawing shows right-hand version. | Measured with master insert: WN .. 060408 / WN .. 080408 / WN .. 100612 | Refer to the Walter online catalogue for more product information: [www.walter-tools.com](http://www.walter-tools.com) | Bodies and assembly parts are included in the scope of delivery

## Assembly parts

Type d <sub>1</sub>	WN .. 0604 .. C4	WN .. 0804 .. C4	WN .. 0804 .. C5-C6	WN .. 1006 .. C5-C6
Shim	AP306-WN06	AP307-WN08	AP307-WN08	AP311-WN10
Screw for shim Tightening torque	FS1462 (T9IP) 1,5 Nm	FS1461 (T15IP) 2,5 Nm	FS1461 (T15IP) 2,5 Nm	FS1463 (T20IP) 5 Nm
Clamp	PK240	PK241	PK241	PK242
Screw for clamp Tightening torque	FS1472 (T9IP) 1,7 Nm	FS1473 (T15IP) 3,9 Nm	FS1473 (T15IP) 3,9 Nm	FS1474 (T20IP) 6,4 Nm
Pressure spring	FS1469	FS1470	FS1470	FS1471
Pin	RS116	RS117	RS117	RS117
Cooling nozzle	FS1477	FS1477	FS1475	FS1475
Torx key	FS1466 (T9IP)	FS1465 (T15IP)	FS1465 (T15IP)	
Allen key				FS1464 (T20IP)

## Accessories

Type	WN .. 0604 ..	WN .. 0804 ..	WN .. 1006 ..
(standard assembly parts) Clamp set	PK240-SET	PK241-SET	PK242-SET
Insert with hole Carbide clamp set		PK245-SET	PK246-SET
Insert with hole Carbide clamp set		PK254-SET	

## Turning tools – Rigid clamping

C...-DWLN...-P 

## Walter Turn

- Precision cooling
- Walter Capto™

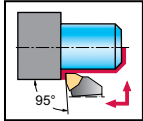

## Tool

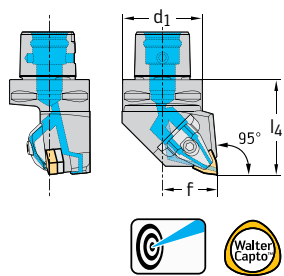

Designation		d <sub>1</sub>	f mm	l <sub>4</sub> mm	D <sub>min</sub> mm	D <sub>min2</sub> mm	γ	λ <sub>s</sub>	Type
C4-DWLN-27050-08-P	8	C4	27	50	500	500	-6°	-6°	WN .. 0804 ..
C5-DWLN-35060-08-P	8	C5	35	60	600	600	-6°	-6°	
C6-DWLN-45065-08-P	8	C6	45	65	600	600	-6°	-6°	
C4-DWLN-27050-08-P	8	C4	27	50	500	500	-6°	-6°	WN .. 0804 ..
C5-DWLN-35060-08-P	8	C5	35	60	600	600	-6°	-6°	
C6-DWLN-45065-08-P	8	C6	45	65	600	600	-6°	-6°	

Walter Capto™ in acc. with ISO 26623

Dimensional drawing shows right-hand version. | Measured with master insert:WN .. 080408 | The maximum recommended coolant pressure is 150 bar (2175 psi) | Refer to the Walter online catalogue for more product information: [www.walter-tools.com](http://www.walter-tools.com) | Bodies and assembly parts are included in the scope of delivery

## Assembly parts

Type	d <sub>1</sub>	WN .. 0804 .. C4–C6
	Shim	AP307-WN08
	Screw for shim Tightening torque	FS1461 (T15IP) 2,5 Nm
	Clamp	PK255
	Screw for clamp Tightening torque	FS1473 (T15IP) 3,9 Nm
	Pressure spring	FS2188
	Torx key	FS1465 (T15IP)

## Accessories

Type	WN .. 0804 ..
	(standard assembly parts) Clamp set
	PK255-SET

## Turning tools – Lever clamping

C...-PWLN 

## Walter Turn

– Walter Capto™

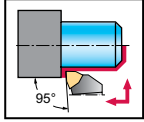

## Tool

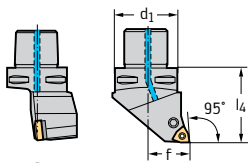

Walter Capto™ in acc. with ISO 26623

Designation		d <sub>1</sub>	f mm	l <sub>4</sub> mm	D <sub>min</sub> mm	D <sub>min2</sub> mm	γ	λ <sub>s</sub>	Type
C3-PWLNR-22040-06	6	C3	22	40	60	116	-6°	-6°	WN .. 0604 ..
C4-PWLNR-27050-06	6	C4	27	50	60	140	-6°	-6°	WN .. 0804 ..
C4-PWLNR-27050-08	8	C4	27	50	60	140	-6°	-6°	
C5-PWLNR-35060-08	8	C5	35	60	65	165	-6°	-6°	WN .. 1006 ..
C6-PWLNR-45065-08	8	C6	45	65	81	190	-6°	-6°	
C5-PWLNR-35060-10	10	C5	35	60	80	165	-6°	-6°	WN .. 0604 ..
C6-PWLNR-45065-10	10	C6	45	65	81	190	-6°	-6°	
C3-PWLNL-22040-06	6	C3	22	40	60	116	-6°	-6°	WN .. 0804 ..
C4-PWLNL-27050-06	6	C4	27	50	60	140	-6°	-6°	
C4-PWLNL-27050-08	8	C4	27	50	60	140	-6°	-6°	WN .. 1006 ..
C5-PWLNL-35060-08	8	C5	35	60	65	165	-6°	-6°	
C6-PWLNL-45065-08	8	C6	45	65	81	190	-6°	-6°	WN .. 0604 ..
C5-PWLNL-35060-10	10	C5	35	60	80	165	-6°	-6°	
C6-PWLNL-45065-10	10	C6	45	65	81	190	-6°	-6°	

Dimensional drawing shows right-hand version. | Measured with master insert: WN .. 060408 / WN .. 080408 / WN .. 100612 | Refer to the Walter online catalogue for more product information: [www.walter-tools.com](http://www.walter-tools.com) | Bodies and assembly parts are included in the scope of delivery

## Assembly parts

Type d <sub>1</sub>	WN .. 0604 .. C3–C4	WN .. 0804 .. C4	WN .. 0804 .. C5–C6	WN .. 1006 .. C5–C6
Shim	AP172-WN0612	AP170-WN0816	AP170-WN0816	AP174-WN1016
Lever	KN101	KN102	KN102	KN104
Clamping screw Tightening torque	FS351 (SW 2,5) 2 Nm	FS352 (SW 3) 5 Nm	FS352 (SW 3) 5 Nm	FS354 (SW 3) 5 Nm
Shim pin	RS101	RS102	RS102	RS103
Tapered assembly pin	MD101	MD101	MD101	MD102
Cooling nozzle	FS1477	FS1477	FS1476	FS1476
Allen key	ISO2936-2,5 (SW 2,5)	ISO2936-3 (SW 3)	ISO2936-3 (SW 3)	ISO2936-3 (SW 3)

## Accessories

Type	WN .. 0604 ..–WN .. 1006 ..	WN .. 0804 ..
Shim		AP170-WN0808

## Turning tools – Screw clamping

C...-SCLC 

## Walter Turn

– Walter Capto™

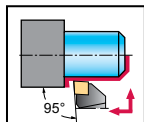

## Tool

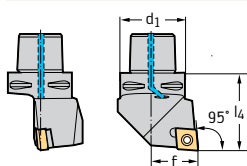

Walter Capto™ in acc. with ISO 26623

Designation		d <sub>1</sub>	f mm	l <sub>4</sub> mm	D <sub>min</sub> mm	D <sub>min2</sub> mm	γ	λ <sub>s</sub>	Type
C3-SCLCR-22040-09	9	C3	22	40	130	116	0°	0°	CC .. 09T3 ..
C4-SCLCR-27050-09	9	C4	27	50	130	140	0°	0°	
C5-SCLCR-35060-09	9	C5	35	60	130	165	0°	0°	
C6-SCLCR-45065-09	9	C6	45	65	130	190	0°	0°	CC .. 1204 ..
C4-SCLCR-27050-12	12	C4	27	50	125	140	0°	0°	
C5-SCLCR-35060-12	12	C5	35	60	125	165	0°	0°	
C6-SCLCR-45065-12	12	C6	45	65	125	190	0°	0°	CC .. 09T3 ..
C3-SCLCL-22040-09	9	C3	22	40	130	116	0°	0°	
C4-SCLCL-27050-09	9	C4	27	50	130	140	0°	0°	
C5-SCLCL-35060-09	9	C5	35	60	130	165	0°	0°	CC .. 1204 ..
C6-SCLCL-45065-09	9	C6	45	65	130	190	0°	0°	
C4-SCLCL-27050-12	12	C4	27	50	125	140	0°	0°	
C5-SCLCL-35060-12	12	C5	35	60	125	165	0°	0°	CC .. 1204 ..
C6-SCLCL-45065-12	12	C6	45	65	125	190	0°	0°	

Dimensional drawing shows right-hand version. | Measured with master insert: CC .. 09T308 / CC .. 120408 | Refer to the Walter online catalogue for more product information: [www.walter-tools.com](http://www.walter-tools.com) | Bodies and assembly parts are included in the scope of delivery

## Assembly parts

Type d <sub>1</sub>	CC .. 09T3 .. C3–C4	CC .. 09T3 .. C5–C6	CC .. 1204 .. C4	CC .. 1204 .. C5–C6
Clamping screw for indexable insert Tightening torque	FS2060 (T15IP) 3 Nm	FS2060 (T15IP) 3 Nm	FS2065 (T15IP) 3 Nm	FS2065 (T15IP) 3 Nm
Shim	AP313-CC0908	AP313-CC0908	AP314-CC1212	AP314-CC1212
Screw for shim	FS2068 (SW 3,5)	FS2068 (SW 3,5)	FS2069 (SW 4)	FS2069 (SW 4)
Torx key	FS1465 (T15IP)	FS1465 (T15IP)	FS1496 (T15IP)	FS1496 (T15IP)
Cooling nozzle	FS1477	FS1476	FS1477	FS1476



## Turning tools - Rigid clamping

C...-DDJC...-P 

## Walter Turn

- Precision cooling
- Walter Capto™

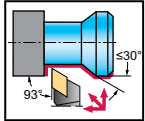

## Tool

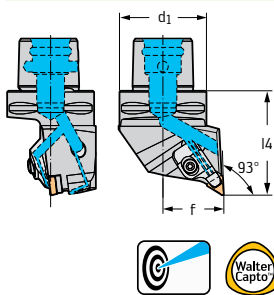

Designation		d <sub>1</sub>	f mm	l <sub>4</sub> mm	D <sub>min</sub> mm	D <sub>min2</sub> mm	γ	λ <sub>s</sub>	Type
C4-DDJCR-27050-11-P	11	C4	27	50	1.200	250	-3°	-7°	DC .. 11T3 ..
C5-DDJCR-35060-11-P	11	C5	35	60	1.400	300	-3°	-7°	
C4-DDJCL-27050-11-P	11	C4	27	50	1.200	250	-3°	-7°	DC .. 11T3 ..
C5-DDJCL-35060-11-P	11	C5	35	60	1.400	300	-3°	-7°	

Walter Capto™ in acc. with ISO 26623

Dimensional drawing shows right-hand version. | Measured with master insert: DC .. 11T308 | The maximum recommended coolant pressure is 150 bar (2175 psi) | Refer to the Walter online catalogue for more product information: [www.walter-tools.com](http://www.walter-tools.com) | Bodies and assembly parts are included in the scope of delivery

## Assembly parts

	Type d <sub>1</sub>	DC .. 11T3 .. C4-C5
	Shim	AP315-DC1108
	Screw for shim	FS2068 (SW 3,5)
	Right clamp	PK261R
	Left clamp	PK261L
	Screw for clamp Tightening torque	FS1473 (T15IP) 3,9 Nm
	Pressure spring	FS2188
	Torx key	FS1465 (T15IP)

## Accessories

	Type	DC .. 11T3 ..
	(standard assembly parts) Right clamp set	PK261R-SET
	(standard assembly parts) Left clamp set	PK261L-SET

## Turning tools – Screw clamping

C...-SDJC 

## Walter Turn

– Walter Capto™

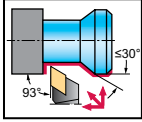

## Tool

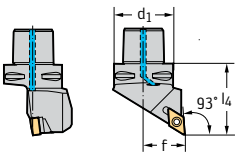

Walter Capto™ in acc. with ISO 26623

Designation		d <sub>1</sub>	f mm	l <sub>4</sub> mm	D <sub>min</sub> mm	D <sub>min2</sub> mm	γ	λ <sub>s</sub>	Type
C3-SDJCR-22040-07	7	C3	22	40	70	116	0°	0°	DC .. 0702 ..
C4-SDJCR-27050-07	7	C4	27	50	70	140	0°	0°	
C3-SDJCR-22040-11	11	C3	22	40	140	116	0°	0°	DC .. 11T3 ..
C4-SDJCR-27050-11	11	C4	27	50	140	140	0°	0°	
C5-SDJCR-35060-11	11	C5	35	60	140	190	0°	0°	
C6-SDJCR-45065-11	11	C6	45	65	140	165	0°	0°	
C3-SDJCL-22040-07	7	C3	22	40	70	116	0°	0°	DC .. 0702 ..
C4-SDJCL-27050-07	7	C4	27	50	70	140	0°	0°	
C3-SDJCL-22040-11	11	C3	22	40	140	116	0°	0°	DC .. 11T3 ..
C4-SDJCL-27050-11	11	C4	27	50	140	140	0°	0°	
C5-SDJCL-35060-11	11	C5	35	60	140	165	0°	0°	
C6-SDJCL-45065-11	11	C6	45	65	140	190	0°	0°	

Dimensional drawing shows right-hand version. | Measured with master insert: DC .. 070204 / DC .. 11T308 | Refer to the Walter online catalogue for more product information: [www.walter-tools.com](http://www.walter-tools.com) | Bodies and assembly parts are included in the scope of delivery

## Assembly parts

Type	d <sub>1</sub>	DC .. 0702 .. C3–C4	DC .. 11T3 .. C3–C4	DC .. 11T3 .. C5–C6
	Clamping screw for indexable insert Tightening torque	FS2061 (T7IP) 0,9 Nm	FS2060 (T15IP) 3 Nm	FS2060 (T15IP) 3 Nm
	Shim		AP315-DC1108	AP315-DC1108
	Screw for shim		FS2068 (SW 3,5)	FS2068 (SW 3,5)
	Torx key	FS1490 (T7IP)	FS1465 (T15IP)	FS1465 (T15IP)
	Cooling nozzle	FS1477	FS1477	FS1476

## Accessories

Type	DC .. 0702 ..	DC .. 11T3 ..
	Shim	AP329-DC1112

## Turning tools – Screw clamping

C...-SDNC 

## Walter Turn

– Walter Capto™

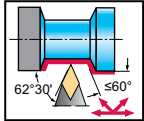

## Tool

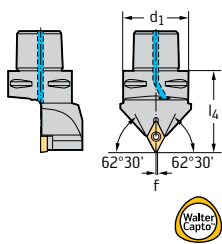

## Designation

d<sub>1</sub>f  
mml<sub>4</sub>  
mmD<sub>min</sub>  
mmD<sub>min2</sub>  
mm

γ

λ<sub>s</sub>

Type

C3-SDNCN-00040-11

11

C3

1

40

116

0°

0°

DC .. 11T3 ..

C4-SDNCN-00050-11

11

C4

1

50

140

0°

0°

C5-SDNCN-00060-11

11

C5

1

60

165

0°

0°

Walter Capto™ in acc. with ISO 26623

Measured with master insert: DC .. 11T308 | Refer to the Walter online catalogue for more product information: [www.walter-tools.com](http://www.walter-tools.com) | Bodies and assembly parts are included in the scope of delivery

## Assembly parts

Type  
d<sub>1</sub>DC .. 11T3 ..  
C3–C4DC .. 11T3 ..  
C5Clamping screw for indexable insert  
Tightening torqueFS2060 (T15IP)  
3 NmFS2060 (T15IP)  
3 Nm

Shim

AP315-DC1108

AP315-DC1108



Screw for shim

FS2068 (SW 3,5)

FS2068 (SW 3,5)

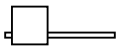

Torx key

FS1465 (T15IP)

FS1465 (T15IP)



Cooling nozzle

FS1477

FS1476

## Accessories

Type

DC .. 11T3 ..



Shim for radius

AP329-DC1112

## Turning tools – Screw clamping

C...-SRDC 

## Walter Turn



– Walter Capto™

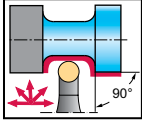

Tool	Designation		d <sub>1</sub>	f mm	l <sub>4</sub> mm	D <sub>min</sub> mm	D <sub>min2</sub> mm	γ	λ <sub>s</sub>	Type
 Walter Capto™ in acc. with ISO 26623	C4-SRDCN-00050-06	6	C4	3	50			0°	0°	RC .. T0602M0 ..
	C5-SRDCN-00060-06	6	C5	3	60			0°	0°	
	C3-SRDCN-00040-08	8	C3	4	40			0°	0°	RC .. T0803M0 ..
	C4-SRDCN-00050-08	8	C4	4	50			0°	0°	
	C5-SRDCN-00060-08	8	C5	4	60			0°	0°	
	C4-SRDCN-00050-10	10	C4	5	50			0°	0°	RC .. T10T3M0 ..
	C5-SRDCN-00060-10	10	C5	5	60			0°	0°	
	C6-SRDCN-00065-10	10	C6	5	65			0°	0°	
	C4-SRDCN-00050-12	12	C4	6	50			0°	0°	RC .. T1204M0 ..
	C5-SRDCN-00060-12	12	C5	6	60			0°	0°	
	C6-SRDCN-00065-12	12	C6	6	65			0°	0°	
	C5-SRDCN-00060-16	16	C5	8	60			0°	0°	RC .. T1606M0 ..
C6-SRDCN-00065-16	16	C6	8	65			0°	0°		

Measured with master insert: RC .. 0803M0 / RC .. 0602M0 / RC .. 10T3M0 / RC .. 1204M0 / RC .. 1606M0 | Refer to the Walter online catalogue for more product information: [www.walter-tools.com](http://www.walter-tools.com) | Bodies and assembly parts are included in the scope of delivery

Assembly parts	Type d <sub>1</sub>	RC .. T0602M0 ..	RC .. T0602M0 ..	RC .. T0803M0 ..	RC .. T0803M0 ..	RC .. T10T3M0 ..	RC .. T10T3M0 ..	RC .. T1204M0 ..	RC .. T1204M0 ..	RC .. T1606M0 ..
		C4	C5	C3-C4	C5	C4	C5-C6	C4	C5-C6	C5-C6
Clamping screw for indexable insert Tightening torque		FS2061 (T7IP) 0,9 Nm	FS2061 (T7IP) 0,9 Nm	FS1462 (T9IP) 1,5 Nm	FS1462 (T9IP) 1,5 Nm	FS2063 (T15IP) 3 Nm	FS2063 (T15IP) 3 Nm	FS2060 (T15IP) 3 Nm	FS2060 (T15IP) 3 Nm	FS2090 (T20IP) 6,4 Nm
Shim						AP324- RC10T3	AP324- RC10T3	AP325- RC1204	AP325- RC1204	AP326- RC1606
Screw for shim						FS2068 (SW 3,5)	FS2068 (SW 3,5)	FS2068 (SW 3,5)	FS2068 (SW 3,5)	FS2091 (SW 5)
Torx key		FS1490 (T7IP)	FS1490 (T7IP)	FS1466 (T9IP)	FS1466 (T9IP)	FS1465 (T15IP)	FS1465 (T15IP)	FS1465 (T15IP)	FS1465 (T15IP)	
Allen key										FS1464 (T20IP)
Cooling nozzle		FS1477	FS1476	FS1477	FS1476	FS1477	FS1476	FS1477	FS1476	FS1476

# Turning tools – Screw clamping

C...-SRSC

## Walter Turn

– Walter Capto™

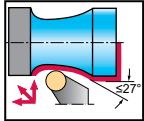

Tool	Designation		d <sub>1</sub>	f mm	l <sub>4</sub> mm	D <sub>min</sub> mm	D <sub>min2</sub> mm	γ	λ <sub>s</sub>	Type
  Walter Capto™ in acc. with ISO 26623	C4-SRSCR-27050-06	6	C4	27	50	160	140	0°	0°	RC . T0602M0 ..
	C4-SRSCR-27050-08	8	C4	27	50	110	140	0°	0°	RC . T0803M0 ..
	C5-SRSCR-35060-08	8	C5	35	60	110	165	0°	0°	RC . T10T3M0 ..
	C4-SRSCR-27050-10	10	C4	27	50	150	140	0°	0°	
	C5-SRSCR-35060-10	10	C5	35	60	150	165	0°	0°	RC . T1204M0 ..
	C6-SRSCR-45065-10	10	C6	45	65	150	190	0°	0°	
	C4-SRSCR-27050-12	12	C4	27	50	150	140	0°	0°	RC . T1606M0 ..
	C5-SRSCR-35060-12	12	C5	35	60	150	165	0°	0°	
	C6-SRSCR-45065-12	12	C6	45	65	175	190	0°	0°	RC . T10T3M0 ..
	C6-SRSCR-45065-16	16	C6	45	65	175	190	0°	0°	
	C4-SRSCCL-27050-06	6	C4	27	50	160	140	0°	0°	RC . T0602M0 ..
	C4-SRSCCL-27050-08	8	C4	27	50	110	140	0°	0°	RC . T0803M0 ..
C5-SRSCCL-35060-08	8	C5	35	60	110	165	0°	0°	RC . T10T3M0 ..	
C4-SRSCCL-27050-10	10	C4	27	50	150	140	0°	0°		
C5-SRSCCL-35060-10	10	C5	35	60	150	165	0°	0°	RC . T1204M0 ..	
C6-SRSCCL-45065-10	10	C6	45	65	150	190	0°	0°		
C4-SRSCCL-27050-12	12	C4	27	50	150	140	0°	0°	RC . T1606M0 ..	
C5-SRSCCL-35060-12	12	C5	35	60	150	165	0°	0°		
C6-SRSCCL-45065-12	12	C6	45	65	150	190	0°	0°	RC . T1606M0 ..	
C6-SRSCCL-45065-16	16	C6	45	65	175	190	0°	0°		

Dimensional drawing shows right-hand version. | Measured with master insert: RC .. 0602M0 / RC .. 0803M0 / RC .. 10T3M0 / RC .. 1204M0 / RC .. 1606M0 | Refer to the Walter online catalogue for more product information: [www.walter-tools.com](http://www.walter-tools.com) | Bodies and assembly parts are included in the scope of delivery

Assembly parts	Type d <sub>1</sub>	RC . T0602M0 .. C4	RC . T0803M0 .. C4	RC . T0803M0 .. C5	RC . T10T3M0 .. C4	RC . T10T3M0 .. C5-C6	RC . T1204M0 .. C4	RC . T1204M0 .. C5-C6	RC . T1606M0 .. C6
	Clamping screw for indexable insert Tightening torque	FS2061 (T7IP) 0,9 Nm	FS1462 (T9IP) 1,5 Nm	FS1462 (T9IP) 1,5 Nm	FS2063 (T15IP) 3 Nm	FS2063 (T15IP) 3 Nm	FS2060 (T15IP) 3 Nm	FS2060 (T15IP) 3 Nm	FS2090 (T20IP) 6,4 Nm
	Shim				AP324- RC10T3	AP324- RC10T3	AP325- RC1204	AP325- RC1204	AP326- RC1606
	Screw for shim				FS2068 (SW 3,5)	FS2068 (SW 3,5)	FS2068 (SW 3,5)	FS2068 (SW 3,5)	FS2091 (SW 5)
	Torx key	FS1490 (T7IP)	FS1466 (T9IP)	FS1466 (T9IP)	FS1465 (T15IP)	FS1465 (T15IP)	FS1465 (T15IP)	FS1465 (T15IP)	
	Allen key								FS1464 (T20IP)
	Cooling nozzle	FS1477	FS1477	FS1476	FS1477	FS1476	FS1477	FS1476	FS1476

## Turning tools – Lever clamping

C...-PRSC 

## Walter Turn

– Walter Capto™

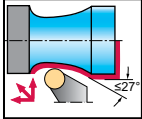

## Tool

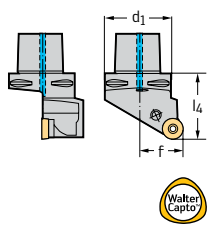

Walter Capto™ in acc. with ISO 26623

Designation		d <sub>1</sub>	f mm	l <sub>4</sub> mm	D <sub>min</sub> mm	D <sub>min2</sub> mm	γ	λ <sub>s</sub>	Type
C5-PRSCR-35060-16	16	C5	35	60			0°	0°	RC .. T1605M0 ..
C5-PRSCR-35060-20	20	C5	35	60			0°	0°	RC .. T2006M0 ..
C6-PRSCR-45065-20	20	C6	45	65			0°	0°	
C8-PRSCR-55080-20	20	C8	55	80	150	250	0°	0°	
C6-PRSCR-45065-25	25	C6	45	65	200	190	0°	0°	RC .. T2507M0 ..
C8-PRSCR-55080-25	25	C8	55	80	200	250	0°	0°	
C5-PRSL-35060-16	16	C5	35	60			0°	0°	RC .. T1605M0 ..
C5-PRSL-35060-20	20	C5	35	60			0°	0°	RC .. T2006M0 ..
C6-PRSL-45065-20	20	C6	45	65			0°	0°	
C8-PRSL-55080-20	20	C8	55	80	150	250	0°	0°	
C6-PRSL-45065-25	25	C6	45	65	200	190	0°	0°	RC .. T2507M0 ..
C8-PRSL-55080-25	25	C8	55	80	200	1.250	0°	0°	

Dimensional drawing shows right-hand version. | Measured with master insert: RC .. 1605M0 / RC .. 2006M0 / RC .. 2507M0 | Refer to the Walter online catalogue for more product information: [www.walter-tools.com](http://www.walter-tools.com) | Bodies and assembly parts are included in the scope of delivery

## Assembly parts

Type d <sub>1</sub>	RC .. T1605M0 .. C5	RC .. T2006M0 .. C5-C6	RC .. T2006M0 .. C8	RC .. T2507M0 .. C6	RC .. T2507M0 .. C8	
	Shim	AP157	AP158	AP404-RC2006	AP405-RC2507	AP405-RC2507
	Lever	KN111	KN112	KN112	KN113	KN113
	Clamping screw Tightening torque	FS344 (SW 2,5) 2,5 Nm	FS2156 (SW 3) 5 Nm	FS2156 (SW 3) 5 Nm	FS2145 (SW 4) 10 Nm	FS2145 (SW 4) 10 Nm
	Shim pin	RS108	RS103	RS103	RS104	RS104
	Tapered assembly pin	MD102	MD102	MD103	MD102	MD102
	Cooling nozzle	FS1019	FS1019	FS1479	FS1476	FS1479
	Allen key	ISO2936-2,5 (SW 2,5)	ISO2936-3 (SW 3)	ISO2936-3 (SW 3)	ISO2936-4 (SW 4)	ISO2936-4 (SW 4)

## Accessories

Type	RC .. T1605M0 ..	RC .. T2006M0 ..-RC .. T2507M0 ..
	Shim for RC .. 1606 ..	AP188

# Turning tools – Screw clamping

C...-STGC mm

## Walter Turn

– Walter Capto™

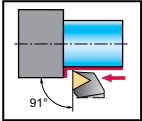
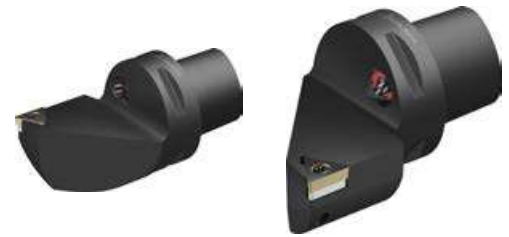

Tool	Designation		d <sub>1</sub>	f mm	l <sub>4</sub> mm	D <sub>min</sub> mm	D <sub>min2</sub> mm	γ	λ <sub>s</sub>	Type
	C4-STGCR-27050-11	11	C4	27	50	90	140	0°	0°	TC .. 1102 ..
	C4-STGCR-27050-16	16	C4	27	50	140	140	0°	0°	TC .. 16T3 ..
	C5-STGCR-35060-16	16	C5	35	60	140	165	0°	0°	
	C4-STGCL-27050-11	11	C4	27	50	90	140	0°	0°	TC .. 1102 ..
	C4-STGCL-27050-16	16	C4	27	50	140	140	0°	0°	TC .. 16T3 ..
	C5-STGCL-35060-16	16	C5	35	60	140	165	0°	0°	

Walter Capto™ in acc. with ISO 26623

Dimensional drawing shows right-hand version. | Measured with master insert: TC .. 110204 / TC .. 16T308 | Refer to the Walter online catalogue for more product information: [www.walter-tools.com](http://www.walter-tools.com) | Bodies and assembly parts are included in the scope of delivery

Assembly parts	Type d <sub>1</sub>	TC .. 1102 ..	TC .. 16T3 ..	TC .. 16T3 ..
		C4	C4	C5
	Clamping screw for indexable insert Tightening torque	FS2061 (T7IP) 0,9 Nm	FS2060 (T15IP) 3 Nm	FS2060 (T15IP) 3 Nm
	Shim		AP317-TC1612	AP317-TC1612
	Screw for shim		FS2068 (SW 3,5)	FS2068 (SW 3,5)
	Torx key	FS1490 (T7IP)	FS1465 (T15IP)	FS1465 (T15IP)
	Cooling nozzle	FS1477	FS1477	FS1476

## Turning tools – Screw clamping

C...-SVHB 

## Walter Turn

– Walter Capto™

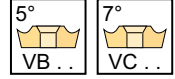
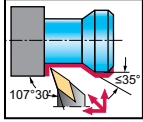

## Tool

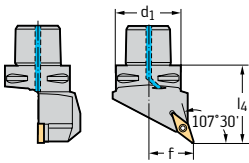

Walter Capto™ in acc. with ISO 26623

Designation		$d_1$	f mm	$l_4$ mm	$D_{min}$ mm	$D_{min2}$ mm	$\gamma$	$\lambda_s$	Type
C3-SVHBR-22040-11	11	C3	22	40	55	114	0°	0°	VB .. 1103 ..
C4-SVHBR-27050-11	11	C4	27	50	55	140	0°	0°	
C4-SVHBR-27050-16	16	C4	27	50	95	140	0°	0°	VB .. 1604 ..
C5-SVHBR-35060-16	16	C5	35	60	95	165	0°	0°	
C6-SVHBR-45065-16	16	C6	45	65	95	190	0°	0°	
C3-SVHBL-22040-11	11	C3	22	40	55	114	0°	0°	VB .. 1103 ..
C4-SVHBL-27050-11	11	C4	27	50	55	140	0°	0°	
C4-SVHBL-27050-16	16	C4	27	50	95	140	0°	0°	VB .. 1604 ..
C5-SVHBL-35060-16	16	C5	35	60	95	165	0°	0°	
C6-SVHBL-45065-16	16	C6	45	65	95	190	0°	0°	

Dimensional drawing shows right-hand version. | Measured with master insert: VB .. 110304 / VB .. 160408 | Refer to the Walter online catalogue for more product information: [www.walter-tools.com](http://www.walter-tools.com) | Bodies and assembly parts are included in the scope of delivery

## Assembly parts

	Type $d_1$	VB .. 1103 .. C3–C4	VB .. 1604 .. C4	VB .. 1604 .. C5–C6
	Clamping screw for indexable insert Tightening torque	FS2061 (T7IP) 0,9 Nm	FS2060 (T15IP) 3 Nm	FS2060 (T15IP) 3 Nm
	Shim		AP316-VB1608	AP316-VB1608
	Screw for shim		FS2068 (SW 3.5)	FS2068 (SW 3.5)
	Torx key	FS1490 (T7IP)	FS1465 (T15IP)	FS1465 (T15IP)
	Cooling nozzle	FS1477	FS1477	FS1476

## Accessories

Type	VB .. 1103 ..	VB .. 1604 ..
		AP330-VB1612



# Turning tools – Screw clamping

C...-SVJB

## Walter Turn

– Walter Capto™

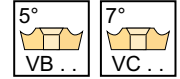
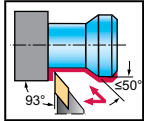

Tool	Designation		d <sub>1</sub>	f mm	l <sub>4</sub> mm	D <sub>min</sub> mm	D <sub>min2</sub> mm	γ	λ <sub>s</sub>	Type	
  Walter Capto™ in acc. with ISO 26623	C3-SVJBR-22040-11	11	C3	22	40	55	116	0°	0°	VB .. 1103 ..	
	C4-SVJBR-27050-11	11	C4	27	50	55	150	0°	0°	VB .. 1604 ..	
	C4-SVJBR-27050-16	16	C4	27	50	155	140	0°	0°		
	C5-SVJBR-35060-16	16	C5	35	60	155	165	0°	0°		
	C6-SVJBR-45065-16	16	C6	C6	45	65	155	190	0°	0°	
	C3-SVJBL-22040-11	11	C3	22	40	55	116	116	0°	0°	VB .. 1103 ..
C4-SVJBL-27050-11	11	C4	27	50	55	150	150	0°	0°	VB .. 1604 ..	
C4-SVJBL-27050-16	16	C4	27	50	155	140	140	0°	0°		
C5-SVJBL-35060-16	16	C5	35	60	155	165	165	0°	0°		
C6-SVJBL-45065-16	16	C6	C6	45	65	155	190	0°	0°		

Dimensional drawing shows right-hand version. | Measured with master insert: VB .. 110304 / VB .. 160408 | Refer to the Walter online catalogue for more product information: [www.walter-tools.com](http://www.walter-tools.com) | Bodies and assembly parts are included in the scope of delivery

Assembly parts		VB .. 1103 .. C3–C4	VB .. 1604 .. C4	VB .. 1604 .. C5–C6
	Clamping screw for indexable insert Tightening torque	FS2061 (T7IP) 0,9 Nm	FS2060 (T15IP) 3 Nm	FS2060 (T15IP) 3 Nm
	Shim		AP316-VB1608	AP316-VB1608
	Screw for shim		FS2068 (SW 3,5)	FS2068 (SW 3,5)
	Torx key	FS1490 (T7IP)	FS1465 (T15IP)	FS1465 (T15IP)
	Cooling nozzle	FS1477	FS1477	FS1476

Accessories		VB .. 1103 ..	VB .. 1604 ..
	Shim		AP330-VB1612

## Turning tools – Rigid clamping

C...-DVJB...-P 

## Walter Turn

- Precision cooling
- Walter Capto™

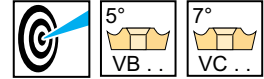
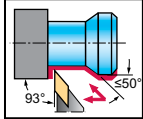

## Tool

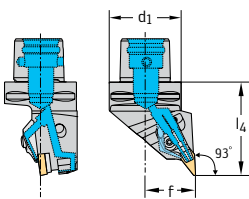

Designation		$d_1$	f mm	$l_4$ mm	$D_{min}$ mm	$D_{min2}$ mm	$\gamma$	$\lambda_s$	Type	
C4-DVJBR-27062-16-P		16	C4	27	62	2.200	250	-2°	-7°	VB .. 1604 ..
C5-DVJBR-35065-16-P		16	C5	35	65	2.400	300	-2°	-7°	
C6-DVJBR-45065-16-P		16	C6	45	65	2.500	350	-2°	-7°	
C8-DVJBR-55080-16-P		16	C8	55	65	2.800	400	-2°	-7°	
C4-DVJBL-27062-16-P		16	C4	27	62	2.200	250	-2°	-7°	VB .. 1604 ..
C5-DVJBL-35065-16-P		16	C5	35	65	2.400	300	-2°	-7°	
C6-DVJBL-45065-16-P		16	C6	45	65	2.500	350	-2°	-7°	
C8-DVJBL-55080-16-P		16	C8	55	65	2.800	400	-2°	-7°	

Walter Capto™ in acc. with ISO 26623

Dimensional drawing shows right-hand version. | Measured with master insert:VB .. 160408 | The maximum recommended coolant pressure is 150 bar (2175 psi) | Refer to the Walter online catalogue for more product information: [www.walter-tools.com](http://www.walter-tools.com) | Bodies and assembly parts are included in the scope of delivery

## Assembly parts

	Type $d_1$	VB .. 1604 .. C4-C8
	Shim	AP312-VN16
	Screw for shim Tightening torque	FS1467 (T15IP) 3 Nm
	Right clamp	PK261R
	Left clamp	PK261L
	Screw for clamp Tightening torque	FS1473 (T15IP) 3,9 Nm
	Pressure spring	FS2188
	Torx key	FS1465 (T15IP)

## Accessories

	Type	VB .. 1604 ..
	(standard assembly parts) Right clamp set	PK261R-SET
	(standard assembly parts) Left clamp set	PK261L-SET

## Turning tools – Screw clamping

C...-SVVB 

## Walter Turn

– Walter Capto™

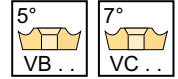
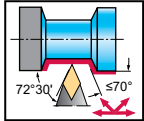

## Tool

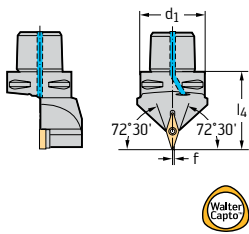

## Designation

Designation		$d_1$	f mm	$l_4$ mm	$D_{min}$ mm	$D_{min2}$ mm	$\gamma$	$\lambda_s$	Type
C4-SVVBN-00050-11		11	0	50		140	0°	0°	VB .. 1103 ..
C4-SVVBN-00050-16		16	1	50		140	0°	0°	VB .. 1604 ..
C5-SVVBN-00060-16		16	1	60		165	0°	0°	
C6-SVVBN-00065-16		16	1	65		190	0°	0°	

Walter Capto™ in acc. with ISO 26623

Measured with master insert: VB .. 110304 / VB .. 160408 | Refer to the Walter online catalogue for more product information: [www.walter-tools.com](http://www.walter-tools.com) | Bodies and assembly parts are included in the scope of delivery

## Assembly parts

	Type $d_1$	VB .. 1103 .. C4	VB .. 1604 .. C4	VB .. 1604 .. C5–C6
	Clamping screw for indexable insert Tightening torque	FS2061 (T7IP) 0,9 Nm	FS2060 (T15IP) 3 Nm	FS2060 (T15IP) 3 Nm
	Shim		AP316-VB1608	AP316-VB1608
	Screw for shim		FS2068 (SW 3,5)	FS2068 (SW 3,5)
	Torx key	FS1490 (T7IP)	FS1465 (T15IP)	FS1465 (T15IP)
	Cooling nozzle	FS1477	FS1477	FS1476

## Accessories

	Type	VB .. 1103 ..	VB .. 1604 ..
	Shim		AP330-VB1612

## Turning tools – Copy turning system

W1011-C...-P

Walter Turn



- Precision cooling
- Walter Capto™

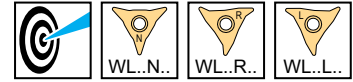
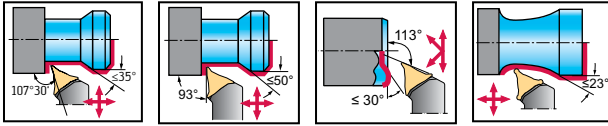

### Tool

Designation		$l_4$ mm	$D_{min2}$ mm	$f$ mm	$\gamma$	$\lambda_s$	Type
W1011-C4R-WL25-P	25	50	200	27	0°	0°	WL25..
W1011-C5R-WL25-P	25	60	200	35	0°	0°	
W1011-C6R-WL25-P	25	65	200	45	0°	0°	
W1011-C4L-WL25-P	25	50	200	27	0°	0°	WL25..
W1011-C5L-WL25-P	25	60	200	35	0°	0°	
W1011-C6L-WL25-P	25	65	200	45	0°	0°	

Walter Capto™ in acc. with ISO 26623

Dimensional drawing shows right-hand version. | Measured with master insert:WL25-VC0708N-MM4 | The maximum recommended coolant pressure is 150 bar (2175 psi) | Refer to the Walter online catalogue for more product information: [www.walter-tools.com](http://www.walter-tools.com) | Bodies and assembly parts are included in the scope of delivery

### Assembly parts

Type	WL25..
 Clamping screw for indexable insert Tightening torque	FS1495 (T20IP) 5 Nm
 Allen key	FS1464 (T20IP)

# Turning tools – Copy turning system

W1010-C...-P

Walter Turn



- Precision cooling
- Walter Capto™

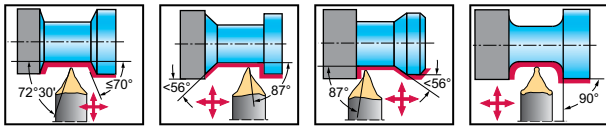

Tool	Designation		$d_1$	f mm	$l_4$ mm	$D_{min2}$ mm	$\gamma$	$\lambda_s$	Type
	W1010-C4N-WL25-P	25	C4	0	50	200	0°	0°	WL25..
	W1010-C5N-WL25-P	25	C5	0	60	200	0°	0°	
	W1010-C6N-WL25-P	25	C6	0	65	200	0°	0°	

Walter Capto™ in acc. with ISO 26623

Measured with master insert:WL25-VC0708N-MM4 | The maximum recommended coolant pressure is 150 bar (2175 psi) | Refer to the Walter online catalogue for more product information: [www.walter-tools.com](http://www.walter-tools.com) | Bodies and assembly parts are included in the scope of delivery

Assembly parts		Type	WL25..
	Clamping screw for indexable insert Tightening torque		FS1495 (T20IP) 5 Nm
	Allen key		FS1464 (T20IP)

**WALTER SELECT** ●● Primary application ● Other application

Best tool for → Good = 😊 → Average = 😐 → Poor = ☹️ machining conditions

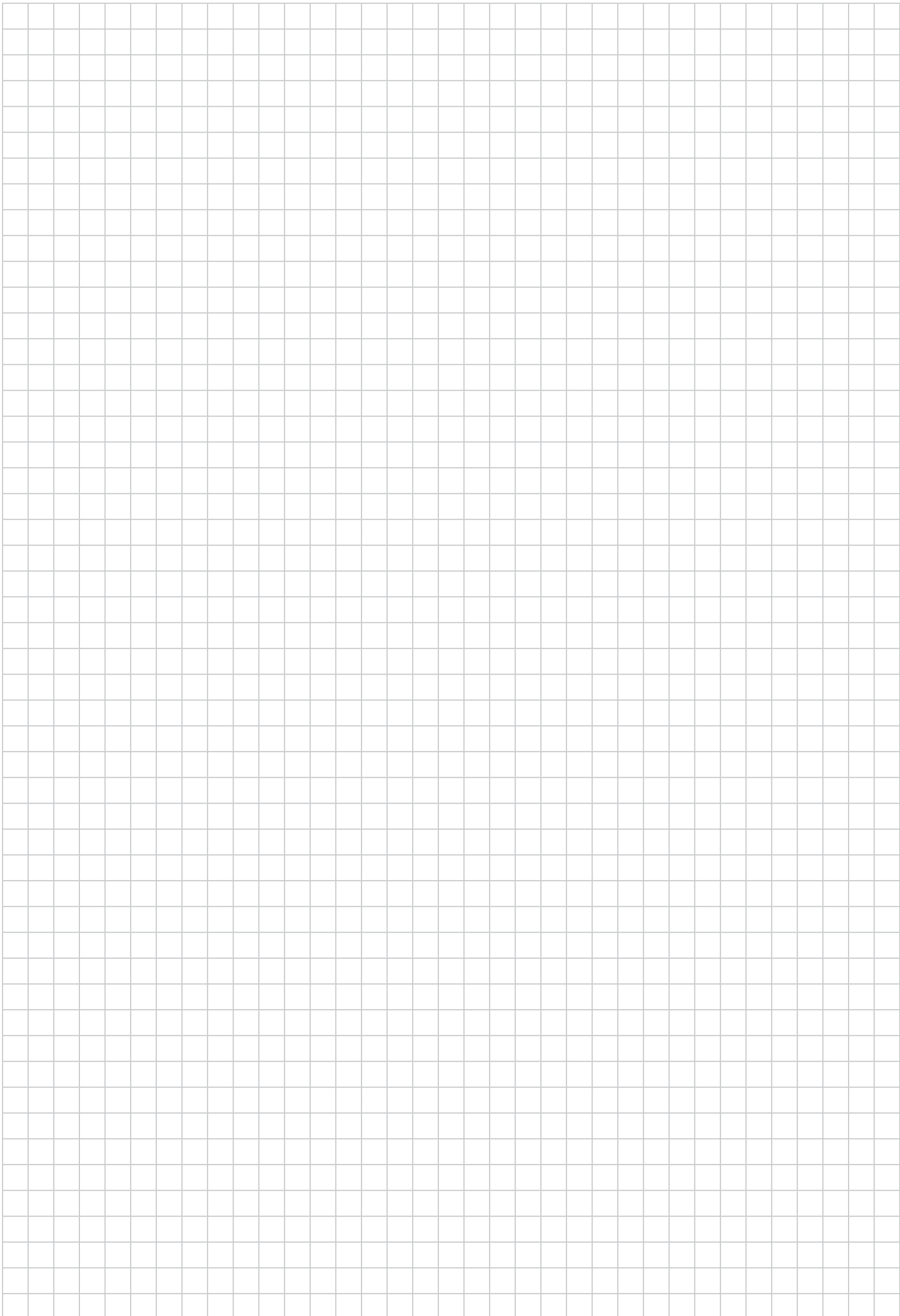

## Turning tools - Rigid clamping

C...-CRSN...-P 

## Walter Turn

- Precision cooling
- For ceramic indexable inserts

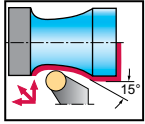

Tool	Designation		$d_1$	f mm	$l_4$ mm	$D_{min}$ mm	$D_{min2}$ mm	$\gamma$	$\lambda_s$	Type
	C6-CRSNR-45065-12-P	12	C6	45	65	600	700	-6°	-6°	RNGN1207 ..
	C6-CRSNL-45065-12-P	12	C6	45	65	600	700	-6°	-6°	RNGN1207 ..

Walter Capto™ in acc. with ISO 26623

Dimensional drawing shows right-hand version. | Measured with master insert:RN .. 120700 | The maximum recommended coolant pressure is 150 bar (2175 psi) | Refer to the Walter online catalogue for more product information: [www.walter-tools.com](http://www.walter-tools.com) | Bodies and assembly parts are included in the scope of delivery

Assembly parts	Type	RNGN1207 ..
	Type $d_1$	C6
	Shim for RN .. 1207 ..	AP418-RN1207
	Screw for shim Tightening torque	FS2241 (T20) 5 Nm
	Clamp	PK268
	Screw for clamp Tightening torque	FS1474 (T20IP) 6,4 Nm
	Pressure spring	FS2298
	Allen key	FS1464 (T20IP)

Accessories	Type	RNGN1207 ..
	(standard assembly parts) Clamp set	PK268-SET
	Shim for RN .. 1204 ..	AP421-RN1204



## 45° turning tools – Rigid clamping

**C...-DCMN** 

### Walter Turn

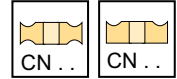
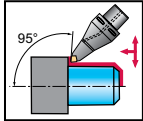

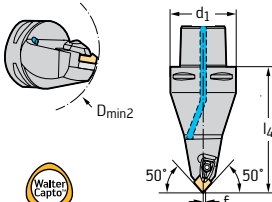



- Walter Capto™
- Toolholders for turning and milling centres





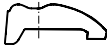

Tool	Designation		d <sub>1</sub>	f mm	l <sub>4</sub> mm	D <sub>min</sub> mm	D <sub>min2</sub> mm	γ	λ <sub>s</sub>	Type	
 	C5-DCMNN-00105-12		12	0	105		110	-6°	-6°	CN .. 1204 ..	
	C6-DCMNN-00090-12		12	0	90		110	-6°	-6°		
	C6-DCMNN-00115-12		12	0	115		110	-6°	-6°		
	C6-DCMNN-00090-16		16	C6	1	90		110	-6°	-6°	CN .. 1606 ..
	C8-DCMNN-00150-16		16	C8	1	150		115	-6°	-6°	

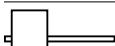
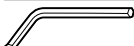
Walter Capto™ in acc. with ISO 26623

 Measured with master insert: CN .. 120408 / CN .. 160612 | Refer to the Walter online catalogue for more product information: [www.walter-tools.com](http://www.walter-tools.com) | Bodies and assembly parts are included in the scope of delivery

Assembly parts		CN .. 1204 .. C5	CN .. 1204 .. C6	CN .. 1606 .. C6-C8
	Shim	AP301-CN12	AP301-CN12	AP302-CN16
	Screw for shim Tightening torque	FS1461 (T15IP) 2,5 Nm	FS1461 (T15IP) 2,5 Nm	FS1463 (T20IP) 5 Nm
	Clamp	PK241	PK241	PK242
	Screw for clamp Tightening torque	FS1473 (T15IP) 3,9 Nm	FS1473 (T15IP) 3,9 Nm	FS1474 (T20IP) 6,4 Nm
	Pressure spring	FS1470	FS1470	FS1471
	Pin	RS117	RS117	RS117
	Cooling nozzle	FS1476	FS1479	FS1479
	Torx key	FS1465 (T15IP)	FS1465 (T15IP)	
	Allen key			FS1464 (T20IP)

Accessories		CN .. 1204 ..	CN .. 1606 ..
	(standard assembly parts) Clamp set	PK241-SET	PK242-SET
	Insert with hole Carbide clamp set	PK245-SET	PK246-SET
	Insert with hole Carbide clamp set	PK254-SET	
	Shim for CN .. 1207 ..	AP411-CN1207	



## 45° turning tools – Rigid clamping

C...-DDMN

### Walter Turn

- Walter Capto™
- Toolholders for turning and milling centres

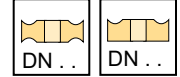
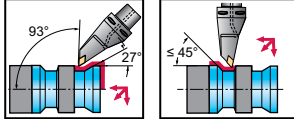

#### Tool

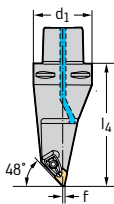
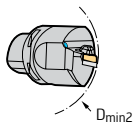

Walter Capto™ in acc. with ISO 26623

Designation		d <sub>1</sub>	f mm	l <sub>4</sub> mm	D <sub>min</sub> mm	D <sub>min2</sub> mm	γ	λ <sub>s</sub>	Type
C5-DDMNL-00115-15		15	C5	1	115		-5°	-6°	DN .. 1506 ..
C6-DDMNL-00130-15		15	C6	1	130		-5°	-6°	
C6-DDMNL-33120-15		15	C6	33	120		-5°	-6°	
C8-DDMNL-00160-15		15	C8	1	160		-5°	-6°	

Measured with master insert: DN .. 150608 | Refer to the Walter online catalogue for more product information: [www.walter-tools.com](http://www.walter-tools.com) | Bodies and assembly parts are included in the scope of delivery

#### Assembly parts

Type	DN .. 1506 .. C5	DN .. 1506 .. C6-C8
Shim	AP304-DN15	AP304-DN15
Screw for shim Tightening torque	FS1461 (T15IP) 2,5 Nm	FS1461 (T15IP) 2,5 Nm
Clamp	PK241	PK241
Screw for clamp Tightening torque	FS1473 (T15IP) 3,9 Nm	FS1473 (T15IP) 3,9 Nm
Pressure spring	FS1470	FS1470
Pin	RS117	RS117
Cooling nozzle	FS1476	FS1479
Torx key	FS1465 (T15IP)	FS1465 (T15IP)

#### Accessories

Type	DN .. 1506 ..
(standard assembly parts) Clamp set	PK241-SET
Insert without hole Carbide clamp set	PK245-SET
Insert without hole Carbide clamp set	PK254-SET
Shim for DN .. 1504 ..	AP304-DN1504
Shim for DN .. 1507 ..	AP412-DN1507

## 45° turning tools – Rigid clamping

C...-DVMN

### Walter Turn

- Walter Capto™
- Toolholders for turning and milling centres

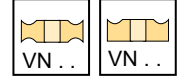
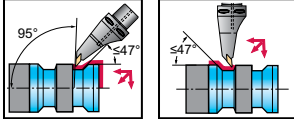

#### Tool

Designation		$d_1$	f mm	$l_4$ mm	$D_{min}$ mm	$D_{min2}$ mm	$\gamma$	$\lambda_s$	Type
C8-DVMNL-00160-16	16	C8	1	160		110	-4°	-14°	VN .. 1604 ..

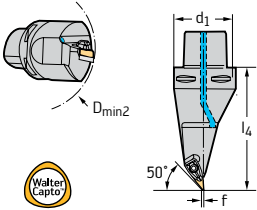

Walter Capto™ in acc. with ISO 26623

Measured with master insert: VN .. 160408 | Refer to the Walter online catalogue for more product information: [www.walter-tools.com](http://www.walter-tools.com) | Bodies and assembly parts are included in the scope of delivery

#### Assembly parts

Type	$d_1$	VN .. 1604 ..
	Shim	AP312-VN16
	Screw for shim Tightening torque	FS1467 (T15IP) 3 Nm
	Clamp	PK244
	Screw for clamp Tightening torque	FS1473 (T15IP) 3,9 Nm
	Pressure spring	FS1470
	Pin	RS117
	Cooling nozzle	FS1479
	Torx key	FS1465 (T15IP)

#### Accessories

Type	VN .. 1604 ..
(standard assembly parts) Clamp set	PK244-SET

# 45° turning tools – Screw clamping

C...-SCMC

## Walter Turn

- Walter Capto™
- Toolholders for turning and milling centres

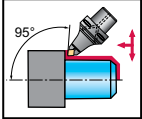

Tool		Designation		$d_1$	f mm	$l_4$ mm	$D_{min}$ mm	$D_{min2}$ mm	$\gamma$	$\lambda_s$	Type
 		C6-SCMCN-00090-12	12	C6	1	90		100	0°	0°	CC .. 1204 ..

Walter Capto™ in acc. with ISO 26623

Measured with master insert: CC .. 120408 | Refer to the Walter online catalogue for more product information: [www.walter-tools.com](http://www.walter-tools.com) | Bodies and assembly parts are included in the scope of delivery

Assembly parts		Type	CC .. 1204 ..
		$d_1$	C6
	Clamping screw for indexable insert Tightening torque		FS2065 (T15IP) 3 Nm
	Shim		AP319-SC1212
	Screw for shim		FS2069 (SW 4)
	Torx key		FS1496 (T15IP)

## 45° turning tools – Screw clamping

C...-SRDC

### Walter Turn

- Walter Capto™
- Toolholders for turning and milling centres

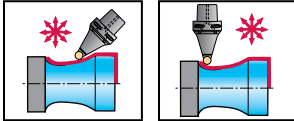

#### Tool

Designation		$d_1$	$f$ mm	$l_4$ mm	$D_{min}$ mm	$D_{min2}$ mm	$\gamma$	$\lambda_s$	Type
C6-SRDCN-00100-10		10	5	100		110	0°	0°	RC..T10T3M0..
C6-SRDCN-00100-16		16	8	100		110	0°	0°	RC..T1606M0..

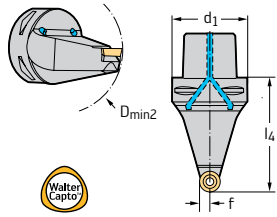

Walter Capto™ in acc. with ISO 26623

Measured with master insert: RC..10T3M0 / RC..1606M0 | Refer to the Walter online catalogue for more product information: [www.walter-tools.com](http://www.walter-tools.com) | Bodies and assembly parts are included in the scope of delivery

#### Assembly parts

Type $d_1$	RC..T10T3M0.. C6	RC..T1606M0.. C6
Clamping screw for indexable insert Tightening torque	FS2063 (T15IP) 3 Nm	FS2090 (T20IP) 6,4 Nm
Shim	AP324-RC10T3	AP326-RC1606
Screw for shim	FS2068 (SW 3,5)	FS2091 (SW 5)
Torx key	FS1465 (T15IP)	
Allen key		FS1464 (T20IP)

## 45° turning tools – Screw clamping

C...-SVMB

### Walter Turn

- Walter Capto™
- Toolholders for turning and milling centres

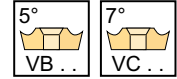
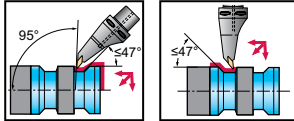

Tool											
		Designation		$d_1$	f mm	$l_4$ mm	$D_{min}$ mm	$D_{min2}$ mm	$\gamma$	$\lambda_s$	Type
		C5-SVMBL-00115-16		16	1	115		110	0°	0°	VB .. 1604 ..
		C6-SVMBL-00130-16		16	1	130		110	0°	0°	
		C6-SVMBL-33120-16		16	33	120		110	0°	0°	

Walter Capto™ in acc. with ISO 26623

Measured with master insert: VB .. 160408 | Refer to the Walter online catalogue for more product information: [www.walter-tools.com](http://www.walter-tools.com) | Bodies and assembly parts are included in the scope of delivery

Assembly parts		Type	VB .. 1604 .. C5–C6
		$d_1$	
	Clamping screw for indexable insert Tightening torque		FS2060 (T15IP) 3 Nm
	Shim		AP316-VB1608
	Screw for shim		FS2068 (SW 3,5)
	Torx key		FS1465 (T15IP)

Accessories		Type	VB .. 1604 ..
	Shim		FS1476

## Boring bars – Negative basic shape

Type		
Machining		



Designation	A...-DCLN	A...-PCLN	A...-DDUN	A...-PDUN
Approach angle	95°	95°	93°	93°
Clamping system	Claw	Lever-type	Claw	Lever-type
Coolant supply	axial	axial	axial	axial
Boring bar $\emptyset d_1$ [mm]	25–50	16–40	25–50	25–40
Boring bar $\emptyset d_1$ [inch]	0,750–2,000		0,750–2,000	
Insert size l [mm]	9–16	9–16	11–15	11–15
Page in catalogue	A 274	A 276	A 277	A 280

QR code				
	<a href="http://www.walter-tools.com/woc/A-DCLN">www.walter-tools.com/woc/A-DCLN</a>	<a href="http://www.walter-tools.com/woc/A-PCLN">www.walter-tools.com/woc/A-PCLN</a>	<a href="http://www.walter-tools.com/woc/A-DDUN">www.walter-tools.com/woc/A-DDUN</a>	<a href="http://www.walter-tools.com/woc/A-PDUN">www.walter-tools.com/woc/A-PDUN</a>

Type			
Machining			



Designation	A...-DDXN	A...-DSKN	A...-PSKN	A...-DTFN
Approach angle	62,5°	75°	75°	91°
Clamping system	Claw	Claw	Lever-type	Claw
Coolant supply	axial	axial	axial	axial
Boring bar $\emptyset d_1$ [mm]	32–40	25–40	25–32	25–50
Boring bar $\emptyset d_1$ [inch]				0,750–2,000
Insert size l [mm]	11–15	12–15	12	16–22
Page in catalogue	A 279	A 281	A 282	A 283

QR code				
	<a href="http://www.walter-tools.com/woc/A-DDXN">www.walter-tools.com/woc/A-DDXN</a>	<a href="http://www.walter-tools.com/woc/A-DSKN">www.walter-tools.com/woc/A-DSKN</a>	<a href="http://www.walter-tools.com/woc/A-PSKN">www.walter-tools.com/woc/A-PSKN</a>	<a href="http://www.walter-tools.com/woc/A-DTFN">www.walter-tools.com/woc/A-DTFN</a>

## Boring bars – Negative basic shape

Type			
Machining			



Designation	A...-PTFN	A...-DVUN	A...-DWLN	A...-PWLN
Approach angle	91°	93°	95°	95°
Clamping system	Lever-type	Claw	Claw	Lever-type
Coolant supply	axial	axial	axial	axial
Boring bar Ø d <sub>1</sub> [mm]	16–32	40	25–50	20–32
Boring bar Ø d <sub>1</sub> [inch]		1,250–1,500	1,000–2,000	
Insert size l [mm]	11–16	16	6–10	6–8
Page in catalogue	A 285	A 286	A 288	A 290

QR code				
<a href="http://www.walter-tools.com/woc/">www.walter-tools.com/woc/</a>	A-PTFN	A-DVUN	A-DWLN	A-PWLN

## Boring bars – Positive basic shape

Type



Machining

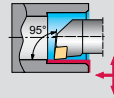

Designation	A...-SCLC	A...-SCLC...-R	E...-SCLC	E...-SCLC...-R
Approach angle	95°	95°	95°	95°
Clamping system	Screw	Screw	Screw	Screw
Coolant supply	axial	axial	axial	axial
Boring bar $\varnothing d_1$ [mm]	8–32	8–20		8–25
Boring bar $\varnothing d_1$ [inch]	0,375–1,250		0,375–1,000	
Insert size l [mm]	6–12	6–9	6–9	6–9
Page in catalogue	A 291	A 291	A 291	A 291

QR code

[www.walter-tools.com/woc/](http://www.walter-tools.com/woc/)

A-SCLC

A-SCLC-R

E-SCLC

E-SCLC-R

Type



Machining

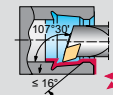
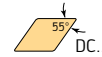
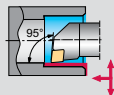

Designation	A...-SCLP	E...-SCLP	A...-SDQC	A...-SDQC...-R
Approach angle	95°	95°	107,5°	107,5°
Clamping system	Screw	Screw	Screw	Screw
Coolant supply	axial	axial	axial	axial
Boring bar $\varnothing d_1$ [mm]			12–25	12–20
Boring bar $\varnothing d_1$ [inch]	0,312–1,000	0,375–0,500		
Insert size l [mm]	6–9	6	7–11	7–11
Page in catalogue	A 296	A 296	A 298	A 298

QR code

[www.walter-tools.com/woc/](http://www.walter-tools.com/woc/)

A-SCLP-E-SCLP

E-SCLP

A-SDQC

A-SDQC-R



## Boring bars – Positive basic shape

Type				
Machining				
Designation	A...-SDUC...-R	A...-SDJC	A...-SDUC	A...-SDUC...-X
Approach angle	93°	93°	93°	93°
Clamping system	Screw	Screw	Screw	Screw
Coolant supply	axial	axial	axial	axial
Boring bar Ø d <sub>1</sub> [mm]	10–20	16–25	10–32	16–32
Boring bar Ø d <sub>1</sub> [inch]			0,375–1,000	1,000–1,250
Insert size l [mm]	7–11	7–11	7–11	7–11
Page in catalogue	A 300	A 307	A 300	A 303
QR code				
	<a href="http://www.walter-tools.com/woc/A-SDUC-R">www.walter-tools.com/woc/A-SDUC-R</a>	<a href="http://www.walter-tools.com/woc/A-SDJC">www.walter-tools.com/woc/A-SDJC</a>	<a href="http://www.walter-tools.com/woc/A-SDUC">www.walter-tools.com/woc/A-SDUC</a>	<a href="http://www.walter-tools.com/woc/A-SDUC-X">www.walter-tools.com/woc/A-SDUC-X</a>

Type				
Machining				
Designation	E...-SDUC	E...-SDUC...-R	A...-SDXC...	A...-SSKC
Approach angle	93°	93°	62,5°	75°
Clamping system	Screw	Screw	Screw	Screw
Coolant supply	axial	axial	axial	axial
Boring bar Ø d <sub>1</sub> [mm]		10–25	12–25	16–25
Boring bar Ø d <sub>1</sub> [inch]	0,375–1,000			
Insert size l [mm]	7–11	7–11	7–11	9–12
Page in catalogue	A 300	A 300	A 308	A 309
QR code				
	<a href="http://www.walter-tools.com/woc/E-SDUC">www.walter-tools.com/woc/E-SDUC</a>	<a href="http://www.walter-tools.com/woc/E-SDUC-R">www.walter-tools.com/woc/E-SDUC-R</a>	<a href="http://www.walter-tools.com/woc/A-SDXC">www.walter-tools.com/woc/A-SDXC</a>	<a href="http://www.walter-tools.com/woc/A-SSKC">www.walter-tools.com/woc/A-SSKC</a>

## Boring bars – Positive basic shape

Type



Machining

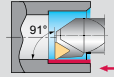

Designation	A...-STFC	A...-STFC...-R	E...-STFC	E...-STFC...-R
Approach angle	91°	91°	91°	91°
Clamping system	Screw	Screw	Screw	Screw
Coolant supply	axial	axial	axial	axial
Boring bar Ø d <sub>1</sub> [mm]	6–32	6–16		6–25
Boring bar Ø d <sub>1</sub> [inch]	0,375–1,250		0,375–1,000	
Insert size l [mm]	6–16	6–11	9–16	6–16
Page in catalogue	A 310	A 310	A 310	A 310

QR code

[www.walter-tools.com/woc/](http://www.walter-tools.com/woc/)

A-STFC

A-STFC-R

E-STFC

E-STFC-R

Type

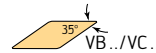

Machining

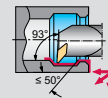
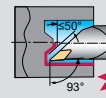
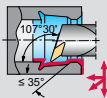

Designation	A...-SVQB	A...-SVQB...-R	A...-SVJB	A...-SVUB
Approach angle	107,5°	107,5°	93°	93°
Clamping system	Screw	Screw	Screw	Screw
Coolant supply	axial	axial	axial	axial
Boring bar Ø d <sub>1</sub> [mm]	16–40	16–20	16–20	16–40
Boring bar Ø d <sub>1</sub> [inch]				0,625–1,500
Insert size l [mm]	11–16	11	11	11–16
Page in catalogue	A 315	A 315	A 317	A 318

QR code

[www.walter-tools.com/woc/](http://www.walter-tools.com/woc/)



A-SVQB

A-SVQB-R

A-SVJB

A-SVUB

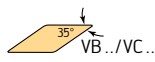
## Boring bars – Positive basic shape

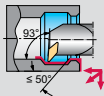
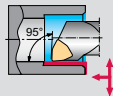
Type		
Machining		



Designation	A...-SVUB...-R	E...-SWLC	A...-SWLC
Approach angle	93°	95°	95°
Clamping system	Screw	Screw	Screw
Coolant supply	axial	axial	axial
Boring bar $\emptyset d_1$ [mm]	16–20		10–25
Boring bar $\emptyset d_1$ [inch]		0,375–0,500	0,375–1,000
Insert size l [mm]	11	4	4–8
Page in catalogue	A 318	A 321	A 321

QR code

[www.walter-tools.com/woc/](http://www.walter-tools.com/woc/)

A-SVUB-R

E-SWLC

A-SWLC

## Boring bars – WL Copy turning system

Type



Machining

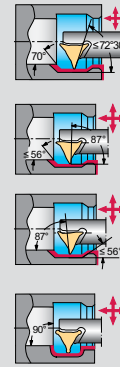
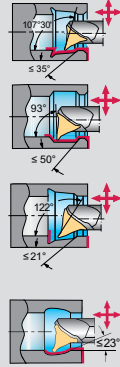

Designation	W1211	W1210	
Approach angle	107,5°	72,5°	
Clamping system	Screw	Screw	
Coolant supply	axial	axial	
Boring bar Ø d <sub>1</sub> [mm]	12–40	12–40	
Boring bar Ø d <sub>1</sub> [inch]	1,000–1,250		
Insert size l [mm]	17–25	17–25	
Page in catalogue	A 324	A 327	

QR code

[www.walter-tools.com/woc/](http://www.walter-tools.com/woc/)

W1211

W1210

## Boring bar adaptor

Type

Machining



Designation

A2140-W

Approach angle

Clamping system

null\_x\_

Coolant supply

axial

Shank size h [mm]

14,2-38,5

Shank size h [Inch]

Insert size l [mm]

Page in catalogue

A 329

QR code

[www.walter-tools.com/woc/](http://www.walter-tools.com/woc/)

A2140-W

## Walter Capto™ boring bars – Negative basic shape

Type		
Machining		



Designation	C...-DCLN	C...-PCLN	C...-DDUN	C...-PDUN
Approach angle	95°	95°	93°	93°
Clamping system	Claw	Lever-type	Claw	Lever-type
Coolant supply	Internal	axial	Internal	axial
Walter Capto™ size	C4–C6	C3–C6	C4–C6	C3–C6
Boring bar Ø d <sub>2</sub> [mm]	25–40	25–50	25–40	25–50
Insert size l [mm]	12–16	12–16	11–15	11–15
Page in catalogue	A 330	A 331	A 333	A 334

QR code				
	<a href="http://www.walter-tools.com/woc/C-DCLN">www.walter-tools.com/woc/C-DCLN</a>	<a href="http://www.walter-tools.com/woc/C-PCLN">www.walter-tools.com/woc/C-PCLN</a>	<a href="http://www.walter-tools.com/woc/C-DDUN">www.walter-tools.com/woc/C-DDUN</a>	<a href="http://www.walter-tools.com/woc/C-PDUN">www.walter-tools.com/woc/C-PDUN</a>

Type			
Machining			



Designation	C...-PSKN	C...-PTFN	C...-DWLN	C...-PWLN
Approach angle	75°	91°	95°	95°
Clamping system	Lever-type	Lever-type	Claw	Lever-type
Coolant supply	axial	axial	Internal	Internal
Walter Capto™ size	C5–C6	C4–C6	C4–C6	C3–C6
Boring bar Ø d <sub>2</sub> [mm]	40–50	25–50	20–40	20–50
Insert size l [mm]	12–15	16–22	6–10	6–8
Page in catalogue	A 336	A 337	A 338	A 339

QR code				
	<a href="http://www.walter-tools.com/woc/C-PSKN">www.walter-tools.com/woc/C-PSKN</a>	<a href="http://www.walter-tools.com/woc/C-PTFN">www.walter-tools.com/woc/C-PTFN</a>	<a href="http://www.walter-tools.com/woc/C-DWLN">www.walter-tools.com/woc/C-DWLN</a>	<a href="http://www.walter-tools.com/woc/C-PWLN">www.walter-tools.com/woc/C-PWLN</a>

## Walter Capto™ boring bars – Positive basic shape

Type				
Machining				



Designation	C...-SCLC	C...-SDUC	C...-STFC	C...-SVQB
Approach angle	95°	93°	91°	107,5°
Clamping system	Screw	Screw	Screw	Screw
Coolant supply	axial	axial	axial	axial
Walter Capto™ size	C3–C5	C3–C5	C4–C5	C3–C6
Boring bar Ø d <sub>2</sub> [mm]	16–40	16–40	16–32	16–50
Insert size l [mm]	9–12	7–11	11–16	11–16
Page in catalogue	A 340	A 341	A 342	A 343

QR code				
<a href="http://www.walter-tools.com/woc/">www.walter-tools.com/woc/</a>	C-SCLC	C-SDUC	C-STFC	C-SVQB

## Vibration-damped boring bar adaptor



Cylinder shaft adaptor –  
vibration damped







Cylinder shaft adaptor –  
vibration damped



Walter Capto™ Adaptor –  
vibration damped



Walter Capto™ Adaptor –  
vibration damped



Designation	A3000	A3001	A3000-C	A3001-C
Machine-side	Parallel shank with clamping surface	Cylindrical shank	Walter Capto™ in acc. with ISO 26623	Walter Capto™ in acc. with ISO 26623
Tool-side	Q25 - Q50	QL60 - QL100	Q25 - Q50	QL60 - QL80
Page in catalogue	A 344	A 346	A 348	A 349
QR code				
<a href="http://www.walter-tools.com/woc/">www.walter-tools.com/woc/</a>	A3000	A3001	A3000-C	A3001-C



HSK-T adaptor – vibration  
damped



HSK-T adaptor – vibration  
damped

Designation	A3000-HSK-T	A3001-HSK-T
Machine-side	HSK DIN 69893-7	HSK DIN 69893-7
Tool-side	Q25 - Q50	QL60 - QL80
Page in catalogue	A 350	A 351
QR code		
<a href="http://www.walter-tools.com/woc/">www.walter-tools.com/woc/</a>	A3000-HSK-T	A3001-HSK-T



## Boring bar adaptor – QuadFit



Cylindrical shank - QuadFit

<b>Designation</b>	A2100	
<b>Machine-side</b>	Parallel shank with clamping surface	
<b>Tool-side</b>	Q40 - QL60	
<b>Page in catalogue</b>	A 352	
<b>QR code</b>		
<a href="http://www.walter-tools.com/woc/">www.walter-tools.com/woc/</a>	A2100	

## Intermediate adaptors – QuadFit Large

Type

Machining



Designation

A2201

Approach angle

Clamping system

Coolant supply

axial

Shank size h [mm]

QL100–QL80

Shank size h [Inch]

QL64–QL76

Insert size l [mm]

Page in catalogue

A 354

QR code

[www.walter-tools.com/woc/](http://www.walter-tools.com/woc/)

A2201

## QuadFit exchangeable head – Negative basic shape

Type			
Machining			



Designation	Q...-DCLN	Q...-DDUN	Q...-DWLN
Approach angle	95°	93°	95°
Clamping system	Claw	Claw	Claw
Coolant supply	axial	axial	axial
QuadFit size	Q32–Q50	Q32–Q50	Q32–Q50
Insert size l [mm]	12–16	11–15	6–8
Page in catalogue	A 356	A 357	A 358

QR code			
<a href="http://www.walter-tools.com/woc/">www.walter-tools.com/woc/</a>	Q-DCLN	Q-DDUN	Q-DWLN

## QuadFit exchangeable head – Positive basic shape

Type				
Machining				
Designation	Q...-SCLC	Q...-SDUC	Q...-SDXC	Q...-SDUC...-X
Approach angle	95°	93°	62,5°	32°
Clamping system	Screw	Screw	Screw	Screw
Coolant supply	axial	axial	axial	axial
QuadFit size	Q25–Q50	Q25–Q50	Q25–Q50	Q25–Q50
Insert size l [mm]	9–12	11	11	11
Page in catalogue	A 359	A 360	A 362	A 360
QR code				
	<a href="http://www.walter-tools.com/woc/Q-SCLC">www.walter-tools.com/woc/Q-SCLC</a>	<a href="http://www.walter-tools.com/woc/Q-SDUC">www.walter-tools.com/woc/Q-SDUC</a>	<a href="http://www.walter-tools.com/woc/Q-SDXC">www.walter-tools.com/woc/Q-SDXC</a>	<a href="http://www.walter-tools.com/woc/Q-SDUC-X">www.walter-tools.com/woc/Q-SDUC-X</a>

Type		
Machining		
Designation	Q...-STFC	Q...-SVUB
Approach angle	91°	93°
Clamping system	Screw	Screw
Coolant supply	axial	axial
QuadFit size	Q25–Q50	Q25–Q50
Insert size l [mm]	11–16	11–16
Page in catalogue	A 363	A 364
QR code		
	<a href="http://www.walter-tools.com/woc/Q-STFC">www.walter-tools.com/woc/Q-STFC</a>	<a href="http://www.walter-tools.com/woc/Q-SVUB">www.walter-tools.com/woc/Q-SVUB</a>

## QuadFit exchangeable head – WL copy turning system

Type



Machining

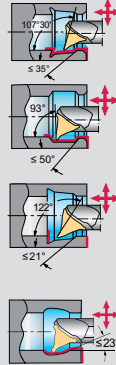

Designation	W1211-Q...
Approach angle	107,5°
Clamping system	Screw
Coolant supply	Precision cooling
Shank size h [mm]	Q32–Q50
Shank size h [Inch]	
Insert size l [mm]	25
Page in catalogue	A 365

QR code

[www.walter-tools.com/woc/](http://www.walter-tools.com/woc/)

W1211-Q

## Boring bar – Rigid clamping

A...-DCLN 

## Walter Turn



– A = Steel version with internal cooling

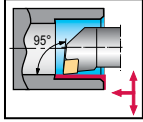

Tool	Designation		$D_{min}$ mm	$d_1$ mm	$f$ mm	$h$ mm	$l_1$ mm	$\gamma$	$\lambda_s$	Type
	A25T-DCLNR12	12	32	25	17	23	300	-6°	-12°	CN .. 1204 ..
	A32T-DCLNR12	12	40	32	22	30	300	-6°	-10°	
	A40T-DCLNR12	12	50	40	27	37	300	-6°	-15°	
	A40T-DCLNR16	16	50	40	27	37	300	-6°	-16°	CN .. 1606 ..
	A50U-DCLNR16	16	63	50	35	47	350	-6°	-13°	
	A25T-DCLNL12	12	32	25	17	23	300	-6°	-12°	CN .. 1204 ..
	A32T-DCLNL12	12	40	32	22	30	300	-6°	-10°	
	A40T-DCLNL12	12	50	40	27	37	300	-6°	-15°	
	A40T-DCLNL16	16	50	40	27	37	300	-6°	-16°	CN .. 1606 ..
	A50U-DCLNL16	16	63	50	35	47	350	-6°	-13°	

Dimensional drawing shows right-hand version. | Measured with master insert: CN .. 120408 / CN .. 160612 | Refer to the Walter online catalogue for more product information: [www.walter-tools.com](http://www.walter-tools.com) | Bodies and assembly parts are included in the scope of delivery

Assembly parts	Type $D_{min}$ [mm]	CN .. 1204 .. 32–40	CN .. 1204 .. 50	CN .. 1606 .. 50–63
	Shim	AP354-CN12	AP301-CN12	AP302-CN16
	Screw for shim Tightening torque	FS1461 (T15IP) 2,5 Nm	FS1461 (T15IP) 2,5 Nm	FS1463 (T20IP) 5 Nm
	Clamp	PK241	PK241	PK242
	Screw for clamp Tightening torque	FS1473 (T15IP) 3,9 Nm	FS1473 (T15IP) 3,9 Nm	FS1474 (T20IP) 6,4 Nm
	Pressure spring	FS1470	FS1470	FS1471
	Pin	RS117	RS117	RS117
	Torx key	FS1465 (T15IP)	FS1465 (T15IP)	
	Allen key			FS1464 (T20IP)

Accessories	Type	CN .. 1204 ..	CN .. 1606 ..
	(standard assembly parts) Clamp set	PK241-SET	PK242-SET
	Insert with hole Carbide clamp set	PK245-SET	PK246-SET
	Insert with hole Carbide clamp set	PK254-SET	

## Boring bar – Rigid clamping

A...-DCLN **inch**

Walter Turn



– A = Steel version with internal cooling

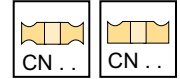
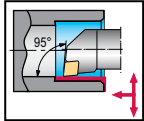

Tool	Designation		$D_{min}$ inch	$d_1$ inch	f inch	h inch	$l_1$ inch	$\gamma$	$\lambda_s$	Type	
<p>Parallel shank with clamping surface</p>	A12S-DCLNR3		9	1,000	0,750	0,64	0,709	10,000	0°	CN .. 0903 .. CN .. 32 ..	
	A16T-DCLNR4		12	1,280	1,000	0,640	0,906	12,000	-6°	-12°	CN .. 1204 .. CN .. 43 ..
	A20T-DCLNR4		12	1,469	1,250	0,765	1,181	12,000	-6°	-11°	
	A24T-DCLNR4		12	1,760	1,500	0,890	1,374	12,000	-6°	-16°	
	A24T-DCLNR5		16	1,760	1,500	0,890	1,374	12,000	-6°	-18°	CN .. 1606 .. CN .. 54 ..
	A32U-DCLNR5		16	2,402	2,000	1,281	1,874	14,000	-6°	-14°	CN .. 1606 .. CN .. 54 ..
	A12S-DCLNL3		9	1,000	0,750	0,64	0,709	10,000	0°		
	A16T-DCLNL4		12	1,280	1,000	0,640	0,906	12,000	-6°	-12°	
	A20T-DCLNL4		12	1,469	1,250	0,765	1,181	12,000	-6°	-11°	CN .. 1204 .. CN .. 43 ..
	A24T-DCLNL4		12	1,760	1,500	0,890	1,374	12,000	-6°	-16°	
	A24T-DCLNL5		16	1,760	1,500	0,890	1,374	12,000	-6°	-18°	
	A32U-DCLNL5		16	2,402	2,000	1,281	1,874	14,000	-6°	-14°	CN .. 1606 .. CN .. 54 ..

Dimensional drawing shows right-hand version. | Measured with master insert: CN .. 090308 / CN .. 120408 / CN .. 160612 | Refer to the Walter online catalogue for more product information: [www.walter-tools.com](http://www.walter-tools.com) | Bodies and assembly parts are included in the scope of delivery

Assembly parts	Type $D_{min}$ [inch]	CN .. 0903 .. 1	CN .. 1204 .. 1,28–1,76	CN .. 1606 .. 1,76–2,402
	Shim	AP414-CN09	AP354-CN12	AP302-CN16
	Screw for shim Tightening torque	FS1462 (T9IP) 1,106 lbs	FS1461 (T15IP) 1,844 lbs	FS1463 (T20IP) 3,688 lbs
	Clamp	PK240	PK241	PK242
	Screw for clamp Tightening torque	FS1472 (T9IP) 1,254 lbs	FS1473 (T15IP) 2,876 lbs	FS1474 (T20IP) 4,72 lbs
	Pressure spring	FS1469	FS1470	FS1471
	Pin	RS116	RS117	RS117
	Torx key	FS1466 (T9IP)	FS1465 (T15IP)	
	Allen key			FS1464 (T20IP)

Accessories	Type	CN .. 0903 ..	CN .. 1204 ..	CN .. 1606 ..
	(standard assembly parts) Clamp set	PK240-SET	PK241-SET	PK242-SET
	Insert with hole Carbide clamp set		PK245-SET	PK246-SET
	Insert with hole Carbide clamp set		PK254-SET	
	CN..1207.. Shim for basic shape		AP411-CN1207	

## Boring bar – Lever clamping

A...-PCLN

### Walter Turn



– A = Steel version with internal cooling

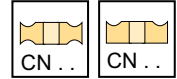
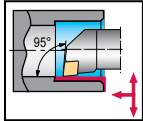

Tool	Designation		D <sub>min</sub> mm	d <sub>1</sub> mm	f mm	h mm	l <sub>1</sub> mm	γ	λ <sub>s</sub>	Type
 Parallel shank with clamping surface	A16R-PCLNR09	9	20	16	11	15	200	-6°	-13°	CN .. 0903 ..
	A20S-PCLNR09	9	25	20	13	18	250	-6°	-11°	
	A25T-PCLNR09	9	32	25	17	23	300	-6°	-10°	
	A25T-PCLNR12	12	32	25	17	23	300	-6°	-10°	CN .. 1204 ..
	A32T-PCLNR12	12	40	32	22	30	300	-6°	-11°	
	A40T-PCLNR12	12	50	40	27	37	300	-6°	-10°	
	A32T-PCLNR16	16	55	32	22	30	300	-6°	-10°	CN .. 1606 ..
	A40T-PCLNR16	16	58	40	27	37	300	-6°	-10°	
	A16R-PCLNL09	9	20	16	11	15	200	-6°	-13°	CN .. 0903 ..
	A20S-PCLNL09	9	25	20	13	18	250	-6°	-11°	
	A25T-PCLNL09	9	32	25	17	23	300	-6°	-10°	
	A25T-PCLNL12	12	32	25	17	23	300	-6°	-10°	CN .. 1204 ..
A32T-PCLNL12	12	40	32	22	30	300	-6°	-11°		
A40T-PCLNL12	12	50	40	27	37	300	-6°	-10°		
A32T-PCLNL16	16	55	32	22	30	300	-6°	-10°	CN .. 1606 ..	
A40T-PCLNL16	16	58	40	27	37	300	-6°	-10°		

Dimensional drawing shows right-hand version. | Measured with master insert: CN .. 090308 / CN .. 120408 / CN .. 160612 | Refer to the Walter online catalogue for more product information: [www.walter-tools.com](http://www.walter-tools.com) | Bodies and assembly parts are included in the scope of delivery

Assembly parts		CN .. 0903 .. 20–32	CN .. 1204 .. 32	CN .. 1204 .. 40	CN .. 1204 .. 50	CN .. 1606 .. 55–58
	Shim			AP134-CN1216	AP134-CN1216	AP135-CN1624
	Lever	KN126	KN128	KN121	KN102	KN104
	Clamping screw Tightening torque	FS2182 (SW 2) 2 Nm	FS332 (SW 2,5) 2,5 Nm	FS2129 (SW 3) 5 Nm	FS352 (SW 3) 5 Nm	FS354 (SW 3) 5 Nm
	Shim pin			RS102	RS102	RS103
	Tapered assembly pin			MD101	MD101	MD102
	Allen key	ISO2936-2 (SW 2)	ISO2936-2,5 (SW 2,5)	ISO2936-3 (SW 3)	ISO2936-3 (SW 3)	ISO2936-3 (SW 3)

Accessories		CN .. 0903 ..	CN .. 1204 ..	CN .. 1606 ..
	Shim		AP134-CN1208	AP135-CN1616



## Boring bar – Rigid clamping

A...-DDUN

### Walter Turn



– A = Steel version with internal cooling

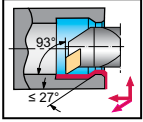

Tool	Designation		D <sub>min</sub> mm	d <sub>1</sub> mm	f mm	h mm	l <sub>1</sub> mm	γ	λ <sub>s</sub>	Type
<p>Parallel shank with clamping surface</p>	A25T-DDUNR11	11	32	25	17	23	300	-6°	-12°	DN .. 1104 ..
	A32T-DDUNR11	11	40	32	22	30	300	-6°	-10°	DN .. 1506 ..
	A32T-DDUNR15	15	40	32	22	30	300	-6°	-14°	
	A40T-DDUNR15	15	50	40	27	37	300	-6°	-11°	
	A50U-DDUNR15	15	63	50	35	47	350	-6°	-8°	
	A25T-DDUNL11	11	32	25	17	23	300	-6°	-12°	DN .. 1104 ..
	A32T-DDUNL11	11	40	32	22	30	300	-6°	-10°	DN .. 1506 ..
	A32T-DDUNL15	15	40	32	22	30	300	-6°	-14°	
	A40T-DDUNL15	15	50	40	27	37	300	-6°	-11°	
	A50U-DDUNL15	15	63	50	35	47	350	-6°	-8°	

Dimensional drawing shows right-hand version. | Measured with master insert: DN .. 110408 / DN .. 150608 | Refer to the Walter online catalogue for more product information: [www.walter-tools.com](http://www.walter-tools.com) | Bodies and assembly parts are included in the scope of delivery

Assembly parts	Type D <sub>min</sub> [mm]	DN .. 1104 ..	DN .. 1506 ..
		32–40	40–63
	Shim	AP305-DN11	AP304-DN15
	Screw for shim Tightening torque	FS1462 (T9IP) 1,5 Nm	FS1461 (T15IP) 2,5 Nm
	Clamp	PK240	PK241
	Screw for clamp Tightening torque	FS1472 (T9IP) 1,7 Nm	FS1473 (T15IP) 3,9 Nm
	Pressure spring	FS1469	FS1470
	Pin	RS116	RS117
	Torx key	FS1466 (T9IP)	FS1465 (T15IP)

Accessories	Type	DN .. 1104 ..	DN .. 1506 ..
	(standard assembly parts) Clamp set	PK240-SET	PK241-SET
	Insert without hole Carbide clamp set		PK245-SET
	Insert without hole Carbide clamp set		PK254-SET
	Shim for DN .. 1504 ..		AP304-DN1504

## Boring bar – Rigid clamping

### A...-DDUN inch

### Walter Turn



– A = Steel version with internal cooling

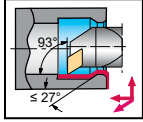

#### Tool

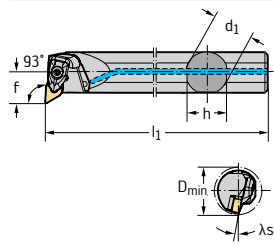

Parallel shank with clamping surface

Designation		$D_{min}$ inch	$d_1$ inch	$f$ inch	$h$ inch	$l_1$ inch	$\gamma$	$\lambda_s$	Type
A12S-DDUNR3	11	1,250	0,750	0,625	0,709	10,000	-6°		DN .. 1104 .. DN .. 33 ..
A16T-DDUNR3	11	1,299	1,000	0,750	0,906	12,000	-6°	-12°	
A16T-DDUNR4	15	1,500	1,000	0,750	0,906	12,000	-6°	-15°	DN .. 1506 .. DN .. 44 ..
A20T-DDUNR4	15	1,705	1,250	1,000	1,181	12,000	-6°	-13°	
A24T-DDUNR4	15	2,000	1,500	1,125	1,374	12,000	-6°	-11°	
A32U-DDUNR4	15	2,677	2,000	1,500	1,874	14,000	-6°	-8°	
A12S-DDUNL3	11	1,250	0,750	0,625	0,709	10,000	-6°		DN .. 1104 .. DN .. 33 ..
A16T-DDUNL3	11	1,299	1,000	0,750	0,906	12,000	-6°	-12°	
A16T-DDUNL4	15	1,500	1,000	0,750	0,906	12,000	-6°	-15°	DN .. 1506 .. DN .. 44 ..
A20T-DDUNL4	15	1,705	1,250	1,000	1,181	12,000	-6°	-13°	
A24T-DDUNL4	15	2,000	1,500	1,125	1,374	12,000	-6°	-11°	
A32U-DDUNL4	15	2,677	2,000	1,500	1,874	14,000	-6°		

Dimensional drawing shows right-hand version. | Measured with master insert: DN .. 110408 / DN .. 150608 | Refer to the Walter online catalogue for more product information: [www.walter-tools.com](http://www.walter-tools.com) | Bodies and assembly parts are included in the scope of delivery

#### Assembly parts

Type	$D_{min}$ (inch)	DN .. 1104 .. 1,25–1,299	DN .. 1506 .. 1,5–2,677
	Shim	AP305-DN11	AP304-DN15
	Screw for shim Tightening torque	FS1462 (T9IP) 1,106 lbs	FS1461 (T15IP) 1,844 lbs
	Clamp	PK240	PK241
	Screw for clamp Tightening torque	FS1472 (T9IP) 1,254 lbs	FS1473 (T15IP) 2,876 lbs
	Pressure spring	FS1469	FS1470
	Pin	RS116	RS117
	Torx key	FS1466 (T9IP)	FS1465 (T15IP)

#### Accessories

Type	DN .. 1104 ..	DN .. 1506 ..
(standard assembly parts) Clamp set	PK240-SET	PK241-SET
Insert with hole Carbide clamp set		PK245-SET
		AP304-DN1504
		AP412-DN1507

## Boring bar – Rigid clamping

A...-DDXN

### Walter Turn

- A = Steel version with internal cooling
- Additional coolant hole for blind hole machining

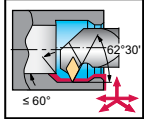

#### Tool

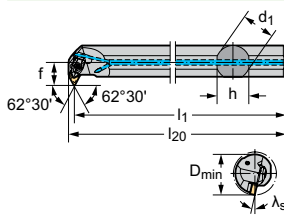

#### Designation

Designation		$D_{min}$ mm	$d_1$ mm	$f$ mm	$h$ mm	$l_1$ mm	$l_{20}$ mm	$\gamma$	$\lambda_s$	Type
A32T-DDXNR11		11	40	22	30	300	306,1	-6°	-10°	DN .. 1104 ..
A40T-DDXNR15		15	50	27	37	300	308,5	-6°	-11°	DN .. 1506 ..
A32T-DDXNL11		11	40	22	30	300	306,1	-6°	-10°	DN .. 1104 ..
A40T-DDXNL15		15	50	27	37	300	308,5	-6°	-11°	DN .. 1506 ..

Parallel shank with clamping surface

Dimensional drawing shows right-hand version. | Measured with master insert: DN .. 110408 / DN .. 150608 | Refer to the Walter online catalogue for more product information: [www.walter-tools.com](http://www.walter-tools.com) | Bodies and assembly parts are included in the scope of delivery

#### Assembly parts

	Type	DN .. 1104 .. 40	DN .. 1506 .. 50
	Shim	AP305-DN11	AP304-DN15
	Screw for shim Tightening torque	FS1462 (T9IP) 1,5 Nm	FS1461 (T15IP) 2,5 Nm
	Clamp	PK240	PK241
	Screw for clamp Tightening torque	FS1472 (T9IP) 1,7 Nm	FS1473 (T15IP) 3,9 Nm
	Pressure spring	FS1469	FS1470
	Pin	RS116	RS117
	Torx key	FS1466 (T9IP)	FS1465 (T15IP)

#### Accessories

	Type	DN .. 1104 ..	DN .. 1506 ..
	(standard assembly parts) Clamp set	PK240-SET	PK241-SET
	Insert without hole Carbide clamp set		PK245-SET
	Insert without hole Carbide clamp set		PK254-SET
	Shim for DN .. 1504 ..		AP304-DN1504

## Boring bar – Lever clamping

A...-PDUN 

## Walter Turn



– A = Steel version with internal cooling

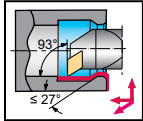

Tool	Designation		D <sub>min</sub> mm	d <sub>1</sub> mm	f mm	h mm	l <sub>1</sub> mm	γ	λ <sub>s</sub>	Type
	A25T-PDUNR11	11	32	25	17	23	300	-6°	-11°	DN .. 1104 ..
	A32T-PDUNR11	11	40	32	22	30	300	-6°	-10°	
	A40T-PDUNR11	11	50	40	27	37	300	-6°	-11°	
	A32T-PDUNR15	15	40	32	22	30	300	-6°	-12°	DN .. 1506 ..
	A40T-PDUNR15	15	50	40	27	37	300	-6°	-11°	
	A25T-PDUNL11	11	32	25	17	23	300	-6°	-11°	DN .. 1104 ..
	A32T-PDUNL11	11	40	32	22	30	300	-6°	-10°	
	A40T-PDUNL11	11	50	40	27	37	300	-6°	-11°	
	A32T-PDUNL15	15	40	32	22	30	300	-6°	-12°	DN .. 1506 ..
	A40T-PDUNL15	15	50	40	27	37	300	-6°	-11°	

Dimensional drawing shows right-hand version. | Measured with master insert: DN .. 110408 / DN .. 150608 | Refer to the Walter online catalogue for more product information: [www.walter-tools.com](http://www.walter-tools.com) | Bodies and assembly parts are included in the scope of delivery

Assembly parts	Type D <sub>min</sub> [mm]	DN .. 1104 ..	DN .. 1104 ..	DN .. 1506 ..
		32	40-50	40-50
	Shim		AP171-DN1112	AP145-DN1516
	Lever	KN120	KN119	KN103
	Clamping screw Tightening torque	FS905 (SW 2) 2 Nm	FS351 (SW 2,5) 2 Nm	FS355 (SW 3) 5 Nm
	Shim pin		RS101	RS102
	Tapered assembly pin		MD101	MD101
	Allen key	ISO2936-2 (SW 2)	ISO2936-2.5 (SW 2.5)	ISO2936-3 (SW 3)

Accessories	Type	DN .. 1104 ..	DN .. 1506 ..
	Shim	AP171-DN1108	AP145-DN1508
	Shim for DN .. 1504 ..		AP357-DN1508
	Shim for DN .. 1504 ..		AP357-DN1516

## Boring bar – Rigid clamping

A...-DSKN

### Walter Turn



– A = Steel version with internal cooling

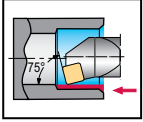

Tool	Designation		D <sub>min</sub> mm	d <sub>1</sub> mm	f mm	h mm	l <sub>1</sub> mm	γ	λ <sub>s</sub>	Type
<p>Parallel shank with clamping surface</p>	A25T-DSKNR12	12	32	25	17	23	300	-6°	-11°	SN .. 1204 ..
	A32T-DSKNR12	12	40	32	22	30	300	-6°	-9°	
	A40T-DSKNR12	12	50	40	27	37	300	-6°	-13°	
	A40T-DSKNR15	15	50	40	27	37	300	-6°	-14°	SN .. 1506 ..
	A25T-DSKNL12	12	32	25	17	23	300	-6°	-11°	SN .. 1204 ..
	A32T-DSKNL12	12	40	32	22	30	300	-6°	-9°	
	A40T-DSKNL12	12	50	40	27	37	300	-6°	-13°	
	A40T-DSKNL15	15	50	40	27	37	300	-6°	-14°	SN .. 1506 ..

Dimensional drawing shows right-hand version. | Measured with master insert: SN .. 120408 / SN .. 150612 | Refer to the Walter online catalogue for more product information: [www.walter-tools.com](http://www.walter-tools.com) | Bodies and assembly parts are included in the scope of delivery

Assembly parts	Type D <sub>min</sub> [mm]	SN .. 1204 .. 32–40	SN .. 1204 .. 50	SN .. 1506 .. 50
	Shim	AP355-SN12	AP308-SN12	AP309-SN15
	Screw for shim Tightening torque	FS1461 (T15IP) 2,5 Nm	FS1461 (T15IP) 2,5 Nm	FS1463 (T20IP) 5 Nm
	Clamp	PK241	PK241	PK242
	Screw for clamp Tightening torque	FS1473 (T15IP) 3,9 Nm	FS1473 (T15IP) 3,9 Nm	FS1474 (T20IP) 6,4 Nm
	Pressure spring	FS1470	FS1470	FS1471
	Pin	RS117	RS117	RS117
	Torx key	FS1465 (T15IP)	FS1465 (T15IP)	
	Allen key			FS1464 (T20IP)

Accessories	Type	SN .. 1204 ..	SN .. 1506 ..
	(standard assembly parts) Clamp set	PK241-SET	PK242-SET
	Insert with hole Carbide clamp set	PK245-SET	PK246-SET
	Insert with hole Carbide clamp set	PK254-SET	

## Boring bar – Lever clamping

A...-PSKN

### Walter Turn



– A = Steel version with internal cooling

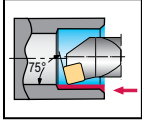

#### Tool

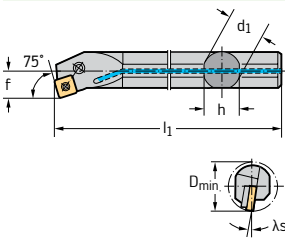

Designation		$D_{min}$ mm	$d_1$ mm	$f$ mm	$h$ mm	$l_1$ mm	$\gamma$	$\lambda_s$	Type
A25T-PSKNR12	12	32	25	17	23	300	-6°	-11°	SN .. 1204 ..
A32T-PSKNR12	12	40	32	22	30	300	-6°	-10°	
A25T-PSKNL12	12	32	25	17	23	300	-6°	-11°	SN .. 1204 ..
A32T-PSKNL12	12	40	32	22	30	300	-6°	-10°	

Parallel shank with clamping surface

Dimensional drawing shows right-hand version. | Measured with master insert: SN .. 120408 | Refer to the Walter online catalogue for more product information: [www.walter-tools.com](http://www.walter-tools.com) | Bodies and assembly parts are included in the scope of delivery

#### Assembly parts

Type	Type	SN .. 1204 .. 32	SN .. 1204 .. 40
	Shim		AP141-SN1216
	Lever	KN128	KN121
	Clamping screw Tightening torque	FS332 (SW 2,5) 2,5 Nm	FS2129 (SW 3) 5 Nm
	Shim pin		RS102
	Tapered assembly pin		MD101
	Allen key	ISO2936-2,5 (SW 2,5)	ISO2936-3 (SW 3)

#### Accessories

Type	Type	SN .. 1204 ..
	Shim	AP141-SN1208

## Boring bar – Rigid clamping

A...-DTFN

### Walter Turn



– A = Steel version with internal cooling

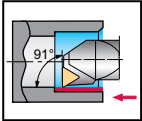

Tool	Designation		D <sub>min</sub> mm	d <sub>1</sub> mm	f mm	h mm	l <sub>1</sub> mm	γ	λ <sub>s</sub>	Type	
 Parallel shank with clamping surface	A25T-DTFNR16		16	32	25	17	23	300	-6°	-12°	TN .. 1604 ..
	A32T-DTFNR16		16	40	32	22	30	300	-6°	-10°	
	A40T-DTFNR16		16	50	40	27	37	300	-6°	-8°	
	A40T-DTFNR22		22	50	40	27	37	300	-6°	-13°	TN .. 2204 ..
	A50U-DTFNR22		22	63	50	35	47	350	-6°	-10°	
	A25T-DTFNL16		16	32	25	17	23	300	-6°	-12°	TN .. 1604 ..
	A32T-DTFNL16		16	40	32	22	30	300	-6°	-10°	
	A40T-DTFNL16		16	50	40	27	37	300	-6°	-8°	
	A40T-DTFNL22		22	50	40	27	37	300	-6°	-13°	TN .. 2204 ..
	A50U-DTFNL22		22	63	50	35	47	350	-6°	-10°	

Dimensional drawing shows right-hand version. | Measured with master insert: TN .. 160408 / TN .. 220408 | Refer to the Walter online catalogue for more product information: [www.walter-tools.com](http://www.walter-tools.com) | Bodies and assembly parts are included in the scope of delivery

Assembly parts	Type D <sub>min</sub> [mm]	TN .. 1604 .. 32–50	TN .. 2204 .. 50–63
	Shim	AP356-TN16	AP322-TN22
	Screw for shim Tightening torque	FS1462 (T9IP) 1,5 Nm	FS1461 (T15IP) 2,5 Nm
	Clamp	PK240	PK241
	Screw for clamp Tightening torque	FS1472 (T9IP) 1,7 Nm	FS1473 (T15IP) 3,9 Nm
	Pressure spring	FS1469	FS1470
	Pin	RS116	RS117
	Torx key	FS1466 (T9IP)	FS1465 (T15IP)

Accessories	Type	TN .. 1604 ..	TN .. 2204 ..
	(standard assembly parts) Clamp set	PK240-SET	PK241-SET
	Insert without hole Carbide clamp set		PK245-SET
	Insert without hole Carbide clamp set		PK254-SET

## Boring bar – Rigid clamping

### A...-DTFN inch

### Walter Turn



– A = Steel version with internal cooling

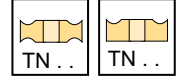
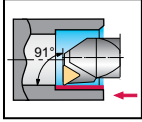

Tool	Designation		D <sub>min</sub> inch	d <sub>1</sub> inch	f inch	h inch	l <sub>1</sub> inch	γ	λ <sub>s</sub>	Type
 Parallel shank with clamping surface	A12S-DTFNR3	16	1,024	0,750	0,500	0,709	10,000	-6°	-14°	TN .. 1604 .. TN .. 33 ..
	A16T-DTFNR3	16	1,201	1,000	0,640	0,906	12,000	-6°	-12°	
	A20T-DTFNR3	16	1,469	1,250	0,765	1,181	12,000	-6°	-11°	
	A24T-DTFNR4	22	1,760	1,500	0,890	1,374	12,000	-6°	-15°	TN .. 2204 .. TN .. 43 ..
	A32U-DTFNR4	22	2,402	2,000	1,281	1,874	14,000	-6°		
	A12S-DTFNL3	16	1,024	0,750	0,500	0,709	10,000	-6°	-14°	TN .. 1604 .. TN .. 33 ..
	A16T-DTFNL3	16	1,201	1,000	0,640	0,906	12,000	-6°	-12°	
	A20T-DTFNL3	16	1,469	1,250	0,765	1,181	12,000	-6°	-11°	
	A24T-DTFNL4	22	1,760	1,500	0,890	1,374	12,000	-6°	-15°	TN .. 2204 .. TN .. 43 ..
	A32U-DTFNL4	22	2,402	2,000	1,281	1,874	14,000	-6°		

Dimensional drawing shows right-hand version. | Measured with master insert: TN .. 160408 / TN .. 220408 | Refer to the Walter online catalogue for more product information: [www.walter-tools.com](http://www.walter-tools.com) | Bodies and assembly parts are included in the scope of delivery

Assembly parts		TN .. 1604 .. 1,024–1,469	TN .. 2204 .. 1,76–2,402
	Shim	AP356-TN16	AP322-TN22
	Screw for shim Tightening torque	FS1462 (T9IP) 1,106 lbs	FS1461 (T15IP) 1,844 lbs
	Clamp	PK240	PK241
	Screw for clamp Tightening torque	FS1472 (T9IP) 1,254 lbs	FS1473 (T15IP) 2,876 lbs
	Pressure spring	FS1469	FS1470
	Pin	RS116	RS117
	Torx key	FS1466 (T9IP)	FS1465 (T15IP)

Accessories		TN .. 1604 ..	TN .. 2204 ..
	(standard assembly parts) Clamp set	PK240-SET	PK241-SET
	Insert with hole Carbide clamp set		PK245-SET



# Boring bar – Lever clamping

A...-PTFN

## Walter Turn



– A = Steel version with internal cooling

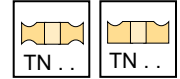
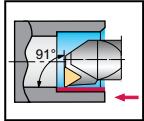

Tool	Designation		D <sub>min</sub> mm	d <sub>1</sub> mm	f mm	h mm	l <sub>1</sub> mm	γ	λ <sub>s</sub>	Type
<p>Parallel shank with clamping surface</p>	A16R-PTFNR11	11	20	16	11	15	200	-6°	-14°	TN .. 1103 ..
	A20S-PTFNR11	11	25	20	13	18	250	-6°	-12°	TN .. 1604 ..
	A25T-PTFNR16	16	32	25	17	23	300	-6°	-13°	
	A32T-PTFNR16	16	50	32	22	30	300	-6°	-12°	
	A16R-PTFNL11	11	20	16	11	15	200	-6°	-14°	TN .. 1103 ..
	A20S-PTFNL11	11	25	20	13	18	250	-6°	-12°	TN .. 1604 ..
	A25T-PTFNL16	16	32	25	17	23	300	-6°	-13°	
	A32T-PTFNL16	16	50	32	22	30	300	-6°	-12°	

Dimensional drawing shows right-hand version. | Measured with master insert: TN .. 110304 / TN .. 160408 | Refer to the Walter online catalogue for more product information: [www.walter-tools.com](http://www.walter-tools.com) | Bodies and assembly parts are included in the scope of delivery

Assembly parts	Type D <sub>min</sub> [mm]	TN .. 1103 .. 20–25	TN .. 1604 .. 32–50
	Shim		AP137-TN1616
	Lever	KN127	KN101
	Clamping screw Tightening torque	FS2182 (SW 2) 2 Nm	FS351 (SW 2,5) 2 Nm
	Shim pin		RS101
	Tapered assembly pin		MD101
	Allen key	ISO2936-2 (SW 2)	ISO2936-2.5 (SW 2,5)

Accessories	Type	TN .. 1103 ..	TN .. 1604 ..
	Shim		AP137-TN1608

## Boring bar – Rigid clamping

A...-DVUN 

## Walter Turn



– A = Steel version with internal cooling

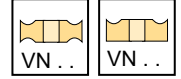
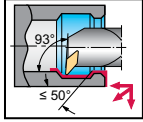

## Tool

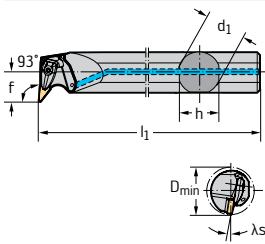

Designation		$D_{min}$ mm	$d_1$ mm	$f$ mm	$h$ mm	$l_1$ mm	$\gamma$	$\lambda_s$	Type
A40T-DVUNR16		16	50	40	27	37	-6°	-9°	VN .. 1604 ..
A40T-DVUNL16		16	50	40	27	37	-6°	-9°	VN .. 1604 ..

Parallel shank with clamping surface

Dimensional drawing shows right-hand version. | Measured with master insert: VN .. 160408 | Refer to the Walter online catalogue for more product information: [www.walter-tools.com](http://www.walter-tools.com) | Bodies and assembly parts are included in the scope of delivery

## Assembly parts

Type	$D_{min}$ [mm]	VN .. 1604 .. 50
Shim		AP312-VN16
Screw for shim Tightening torque		FS1467 (T15IP) 3 Nm
Clamp		PK244
Screw for clamp Tightening torque		FS1473 (T15IP) 3,9 Nm
Pressure spring		FS1470
Pin		RS117
Torx key		FS1465 (T15IP)

## Accessories

Type	VN .. 1604 ..
(standard assembly parts) Clamp set	PK244-SET

# Boring bar – Rigid clamping

A...-DVUN inch

**Walter Turn**



– A = Steel version with internal cooling

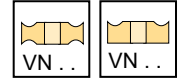
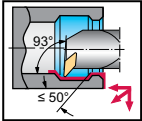

Tool	Designation		D <sub>min</sub> inch	d <sub>1</sub> inch	f inch	h inch	l <sub>1</sub> inch	γ	λ <sub>s</sub>	Type
	A20T-DVUNR3	16	1,705	1,250	1,000	1,181	12,000	-6°	-9°	VN .. 1604 .. VN .. 33 ..
	A24T-DVUNR3	16	2,000	1,500	1,125	1,374	12,000	-6°	-8°	
	A20T-DVUNL3	16	1,705	1,250	1,000	1,181	12,000	-6°	-9°	VN .. 1604 .. VN .. 33 ..
	A24T-DVUNL3	16	2,000	1,500	1,125	1,374	12,000	-6°	-8°	

Parallel shank with clamping surface

Dimensional drawing shows right-hand version. | Measured with master insert:VN .. 160408 | Refer to the Walter online catalogue for more product information: [www.walter-tools.com](http://www.walter-tools.com) | Bodies and assembly parts are included in the scope of delivery

Assembly parts	Type	D <sub>min</sub> [inch]	VN .. 1604 .. 1,705–2
	Shim		AP312-VN16
	Screw for shim Tightening torque		FS1467 (T15IP) 2,213 lbs
	Clamp		PK244
	Screw for clamp Tightening torque		FS1473 (T15IP) 2,876 lbs
	Pressure spring		FS1470
	Pin		RS117
	Torx key		FS1465 (T15IP)

Accessories	Type	VN .. 1604 ..
	(standard assembly parts) Clamp set	PK244-SET

## Boring bar – Rigid clamping

A...-DWLN

### Walter Turn



– A = Steel version with internal cooling

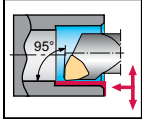

#### Tool

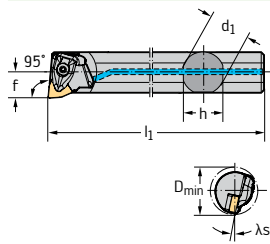

Parallel shank with clamping surface

Designation		$D_{min}$ mm	$d_1$ mm	$f$ mm	$h$ mm	$l_1$ mm	$\gamma$	$\lambda_s$	Type
A25T-DWLNRO6		6	32	25	17	23	-6°	-14°	WN .. 0604 ..
A32T-DWLNRO6		6	40	32	22	30	-6°	-11°	
A25T-DWLNRO8		8	32	25	17	23	-6°	-12°	WN .. 0804 ..
A32T-DWLNRO8		8	40	32	22	30	-6°	-10°	
A40T-DWLNRO8		8	50	40	27	37	-6°	-13°	
A50U-DWLNRO8		8	63	50	35	47	-6°	-11°	
A40T-DWLNRO10		10	50	40	27	37	-6°	-16°	WN .. 1006 ..
A25T-DWLNLO6		6	32	25	17	23	-6°	-14°	WN .. 0604 ..
A32T-DWLNLO6		6	40	32	22	30	-6°	-11°	
A25T-DWLNLO8		8	32	25	17	23	-6°	-12°	WN .. 0804 ..
A32T-DWLNLO8		8	40	32	22	30	-6°	-10°	
A40T-DWLNLO8		8	50	40	27	37	-6°	-13°	
A50U-DWLNLO8		8	63	50	35	47	-6°	-11°	
A40T-DWLNLO10		10	50	40	27	37	-6°	-16°	WN .. 1006 ..

Dimensional drawing shows right-hand version. | Measured with master insert: WN .. 060408 / WN .. 080408 / WN .. 100612 | Refer to the Walter online catalogue for more product information: [www.walter-tools.com](http://www.walter-tools.com) | Bodies and assembly parts are included in the scope of delivery

#### Assembly parts

Type	$D_{min}$ [mm]	WN .. 0604 .. 32–40	WN .. 0804 .. 32–40	WN .. 0804 .. 50–63	WN .. 1006 .. 50
	Shim	AP306-WN06	AP331-WN08	AP307-WN08	AP311-WN10
	Screw for shim Tightening torque	FS1462 (T9IP) 1,5 Nm	FS1461 (T15IP) 2,5 Nm	FS1461 (T15IP) 2,5 Nm	FS1463 (T20IP) 5 Nm
	Clamp	PK240	PK241	PK241	PK242
	Screw for clamp Tightening torque	FS1472 (T9IP) 1,7 Nm	FS1473 (T15IP) 3,9 Nm	FS1473 (T15IP) 3,9 Nm	FS1474 (T20IP) 6,4 Nm
	Pressure spring	FS1469	FS1470	FS1470	FS1471
	Pin	RS116	RS117	RS117	RS117
	Torx key	FS1466 (T9IP)	FS1465 (T15IP)	FS1465 (T15IP)	
	Allen key				FS1464 (T20IP)

#### Accessories

Type	WN .. 0604 ..	WN .. 0804 ..	WN .. 1006 ..
(standard assembly parts) Clamp set	PK240-SET	PK241-SET	PK242-SET
Insert with hole Carbide clamp set		PK245-SET	PK246-SET
Insert with hole Carbide clamp set		PK254-SET	

## Boring bar – Rigid clamping

A...-DWLN inch

**Walter Turn**



– A = Steel version with internal cooling

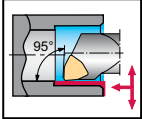

### Tool

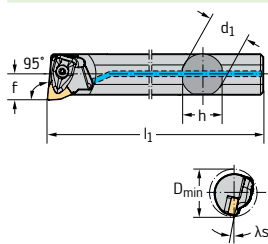

Parallel shank with clamping surface

Designation		$D_{min}$ inch	$d_1$ inch	$f$ inch	$h$ inch	$l_1$ inch	$\gamma$	$\lambda_s$	Type
A16T-DWLN3		6	1,299	1,000	0,750	0,906	-6°	-14°	WN .. 0604 .. WN .. 33 ..
A20T-DWLN3		6	1,705	1,250	1,000	1,181	-6°	-10°	
A16T-DWLN4		8	1,299	1,000	0,750	0,906	-6°	-12°	WN .. 0804 .. WN .. 43 ..
A20T-DWLN4		8	1,705	1,250	1,000	1,181	-6°	-15°	
A24T-DWLN4		8	2,000	1,500	1,000	1,374	-6°	-13°	
A32U-DWLN4		8	2,500	2,000	1,325	1,874	-6°	-11°	
A16T-DWLN3		6	1,299	1,000	0,750	0,906	-6°	-14°	WN .. 0604 .. WN .. 33 ..
A20T-DWLN3		6	1,705	1,250	1,000	1,181	-6°	-10°	
A16T-DWLN4		8	1,299	1,000	0,750	0,906	-6°	-12°	WN .. 0804 .. WN .. 43 ..
A20T-DWLN4		8	1,705	1,250	1,000	1,181	-6°	-15°	
A24T-DWLN4		8	2,000	1,500	1,000	1,374	-6°	-13°	
A32U-DWLN4		8	2,500	2,000	1,325	1,874	-6°	-11°	

Dimensional drawing shows right-hand version. | Measured with master insert: WN .. 060408 / WN .. 080408 | Refer to the Walter online catalogue for more product information: [www.walter-tools.com](http://www.walter-tools.com) | Bodies and assembly parts are included in the scope of delivery

### Assembly parts

Type	Type	WN .. 0604 .. 1,299–1,705	WN .. 0804 .. 1,299–1,705	WN .. 0804 .. 2–2,5
	Shim	AP306-WN06	AP307-WN08	AP331-WN08
	Screw for shim Tightening torque	FS1462 (T9IP) 1,106 lbs	FS1461 (T15IP) 1,844 lbs	FS1461 (T15IP) 1,844 lbs
	Clamp	PK240	PK241	PK241
	Screw for clamp Tightening torque	FS1472 (T9IP) 1,254 lbs	FS1473 (T15IP) 2,876 lbs	FS1473 (T15IP) 2,876 lbs
	Pressure spring	FS1469	FS1470	FS1470
	Pin	RS116	RS117	RS117
	Torx key	FS1466 (T9IP)	FS1465 (T15IP)	FS1465 (T15IP)

### Accessories

Type	Type	WN .. 0604 ..	WN .. 0804 ..
	(standard assembly parts) Clamp set	PK240-SET	PK241-SET
	Insert with hole Carbide clamp set		PK245-SET

## Boring bar – Lever clamping

A...-PWLN

### Walter Turn



– A = Steel version with internal cooling

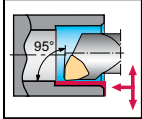

Tool	Designation		D <sub>min</sub> mm	d <sub>1</sub> mm	f mm	h mm	l <sub>1</sub> mm	γ	λ <sub>s</sub>	Type
	A20S-PWLN06	6	25	20	13	18	250	-6°	-15°	WN .. 0604 ..
	A25T-PWLN06	6	32	25	17	23	300	-6°	-12°	WN .. 0804 ..
	A25T-PWLN08	8	32	25	17	23	300	-6°	-10°	
	A32T-PWLN08	8	40	32	22	30	300	-6°	-10°	
	A20S-PWLN06	6	25	20	13	18	250	-6°	-15°	WN .. 0604 ..
	A25T-PWLN06	6	32	25	17	23	300	-6°	-12°	WN .. 0804 ..
	A25T-PWLN08	8	32	25	17	23	300	-6°	-10°	
	A32T-PWLN08	8	40	32	22	30	300	-6°	-10°	

Parallel shank with clamping surface

Dimensional drawing shows right-hand version. | Measured with master insert: WN .. 060408 / WN .. 080408 | Refer to the Walter online catalogue for more product information: [www.walter-tools.com](http://www.walter-tools.com) | Bodies and assembly parts are included in the scope of delivery

Assembly parts	Type D <sub>min</sub> [mm]	WN .. 0604 .. 25–32	WN .. 0804 .. 32	WN .. 0804 .. 40
	Shim			AP170-WN0816
	Lever	KN108	KN128	KN102
	Clamping screw Tightening torque	FS331 (SW 2) 2 Nm	FS332 (SW 2,5) 2,5 Nm	FS352 (SW 3) 5 Nm
	Shim pin			RS102
	Tapered assembly pin			MD101
	Allen key	ISO2936-2 (SW 2)	ISO2936-2,5 (SW 2,5)	ISO2936-3 (SW 3)

Accessories	Type	WN .. 0604 ..	WN .. 0804 ..
	Shim		AP170-WN0808

## Boring bar – Screw clamping

A...-SCLC

### Walter Turn



– A = Steel version with internal cooling

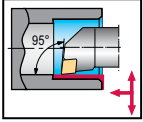

#### Tool

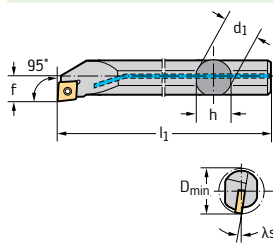

Parallel shank with clamping surface

Designation		$D_{min}$ mm	$d_1$ mm	f mm	h mm	$l_1$ mm	$\gamma$	$\lambda_s$	Type	
A08H-SCLCR06		6	10	8	5	7	100	0°	-13,8°	CC .. 0602 ..
A10K-SCLCR06		6	12	10	6	9	125	0°	-10,9°	
A12M-SCLCR06		6	16	12	9	11	150	0°	-7,3°	
A16R-SCLCR09		9	20	16	11	15	200	0°	-8,4°	CC .. 09T3 ..
A20S-SCLCR09		9	25	20	13	18	250	0°	-5,8°	
A25T-SCLCR09		9	32	25	17	23	300	0°	-3,4°	
A25T-SCLCR12		12	32	25	17	23	300	0°	-4,6°	CC .. 1204 ..
A32T-SCLCR12		12	40	32	22	30	300	0°	-9,8°	
A08H-SCLCL06		6	10	8	5	7	100	0°	-13,8°	CC .. 0602 ..
A10K-SCLCL06		6	12	10	6	9	125	0°	-10,9°	
A12M-SCLCL06		6	16	12	9	11	150	0°	-7,3°	
A16R-SCLCL09		9	20	16	11	15	200	0°	-8,4°	CC .. 09T3 ..
A20S-SCLCL09		9	25	20	13	18	250	0°	-5,8°	
A25T-SCLCL09		9	32	25	17	23	300	0°	-3,4°	
A25T-SCLCL12		12	32	25	17	23	300	0°	-4,6°	CC .. 1204 ..
A32T-SCLCL12		12	40	32	22	30	300	0°	-9,8°	

Dimensional drawing shows right-hand version. | Measured with master insert: CC .. 060204 / CC .. 09T308 / CC .. 120408 | Refer to the Walter online catalogue for more product information: [www.walter-tools.com](http://www.walter-tools.com) | Bodies and assembly parts are included in the scope of delivery

#### Assembly parts

Type	Type	CC .. 0602 .. 10–16	CC .. 09T3 .. 20–25	CC .. 09T3 .. 32	CC .. 1204 .. 32	CC .. 1204 .. 40
	Clamping screw for indexable insert Tightening torque	FS2066 (T7IP) 0,9 Nm	FS2062 (T15IP) 3 Nm	FS2063 (T15IP) 3 Nm	FS2064 (T15IP) 3 Nm	FS2065 (T15IP) 3 Nm
	Shim					AP314-CC1212
	Screw for shim					FS2069 (SW 4)
	Torx key	FS1490 (T7IP)	FS1465 (T15IP)	FS1465 (T15IP)	FS1496 (T15IP)	FS1496 (T15IP)

## Boring bar – Screw clamping

A...-SCLC...-R 

## Walter Turn



– A = Steel version with internal cooling

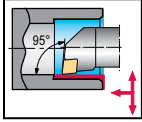

## Tool

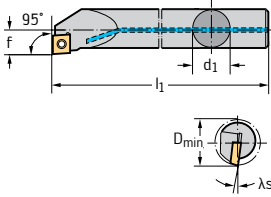
Designation		$D_{min}$ mm	$d_1$ mm	$f$ mm	$l_1$ mm	$\gamma$	$\lambda_s$	Type
A08H-SCLCR06-R		6	10	5	100	0°	-13,8°	CC .. 0602 ..
A10K-SCLCR06-R		6	12	6	125	0°	-10,9°	
A12M-SCLCR06-R		6	16	9	150	0°	-7,3°	
A16R-SCLCR09-R		9	20	11	200	0°	-8,4°	CC .. 09T3 ..
A20S-SCLCR09-R		9	25	13	250	0°	-5,8°	
A08H-SCLCL06-R		6	10	5	100	0°	-13,8°	CC .. 0602 ..
A10K-SCLCL06-R		6	12	6	125	0°	-10,9°	
A12M-SCLCL06-R		6	16	9	150	0°	-7,3°	
A16R-SCLCL09-R		9	20	11	200	0°	-8,4°	CC .. 09T3 ..
A20S-SCLCL09-R		9	25	13	250	0°	-5,8°	

Dimensional drawing shows right-hand version. | Measured with master insert: CC .. 060204 / CC .. 09T308 | Refer to the Walter online catalogue for more product information: [www.walter-tools.com](http://www.walter-tools.com) | Bodies and assembly parts are included in the scope of delivery

## Assembly parts

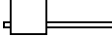
Type	Type	CC .. 0602 .. 10–16	CC .. 09T3 .. 20–25
	Clamping screw for indexable insert Tightening torque	FS2066 (T7IP) 0,9 Nm	FS2062 (T15IP) 3 Nm
	Torx key	FS1490 (T7IP)	FS1465 (T15IP)



## Boring bar – Screw clamping

E...-SCLC...-R mm

### Walter Turn



– E = Solid carbide version with internal cooling

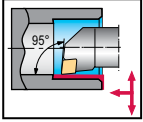

#### Tool

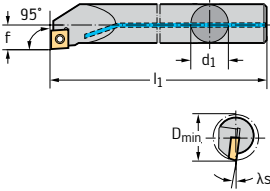
Designation		$D_{min}$ mm	$d_1$ mm	f mm	$l_1$ mm	$\gamma$	$\lambda_s$	Type		
E08K-SCLCR06-R	 <p>Cylindrical shank</p>	6	10	8	5	125	0°	-13,8°	CC .. 0602 ..	
E10M-SCLCR06-R		6	12	10	6	150	0°	-10,9°		
E12Q-SCLCR06-R		6	16	12	9	180	0°	-7,3°		
E16R-SCLCR09-R		CC .. 09T3 ..	9	20	16	11	200	0°	-8,4°	
E20S-SCLCR09-R			9	25	20	13	220	0°	-6°	
E25T-SCLCR09-R			9	32	25	17	270	0°	-3°	
E08K-SCLCL06-R			CC .. 0602 ..	6	10	8	5	125	0°	-13,8°
E10M-SCLCL06-R				6	12	10	6	150	0°	-10,9°
E12Q-SCLCL06-R		6		16	12	9	180	0°	-7,3°	
E16R-SCLCL09-R		CC .. 09T3 ..		9	20	16	11	200	0°	-8,4°
E20S-SCLCL09-R				9	25	20	13	220	0°	-6°
E25T-SCLCL09-R				9	32	25	17	270	0°	-3°

Dimensional drawing shows right-hand version. | Measured with master insert: CC .. 060204 / CC .. 09T308 | Refer to the Walter online catalogue for more product information: [www.walter-tools.com](http://www.walter-tools.com) | Bodies and assembly parts are included in the scope of delivery

#### Assembly parts

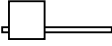
Type	Type	CC .. 0602 .. 10–16	CC .. 09T3 .. 20–25	CC .. 09T3 .. 32
 Clamping screw for indexable insert Tightening torque	FS2066 (T7IP) 0,9 Nm	FS2062 (T15IP) 3 Nm	FS2063 (T15IP) 3 Nm	
 Torx key	FS1490 (T7IP)	FS1465 (T15IP)	FS1465 (T15IP)	

## Boring bar – Screw clamping

### A...-SCLC inch

### Walter Turn



– A = Steel version with internal cooling

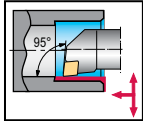

#### Tool

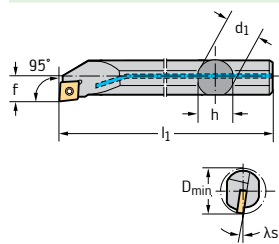

Parallel shank with clamping surface

Designation		$D_{min}$ inch	$d_1$ inch	f inch	h inch	$l_1$ inch	$\gamma$	$\lambda_s$	Type	
A06M-SCLCR2		6	0,48	0,375	0,250	0,336	6,000	0°	-10,696°	CC .. 0602 .. CC .. 2(1.5) ..
A08M-SCLCR2		6	0,598	0,500	0,312	0,460	6,000	0°	-7,86°	
A10R-SCLCR2		6	0,772	0,625	0,406	0,562	8,000	0°	-5,34°	
A10R-SCLCR3		9	0,772	0,625	0,406	0,562	8,000	0°	-8,696°	CC .. 09T3 .. CC .. 3(2.5) ..
A12S-SCLCR3		9	0,929	0,750	0,500	0,709	10,000	0°	-6,371°	
A16T-SCLCR3		9	1,201	1,000	0,640	0,906	12,000	0°	-3,834°	
A16T-SCLCR4		12	1,201	1,000	0,640	0,906	12,000	0°	-5,103°	CC .. 1204 .. CC .. 43 ..
A20T-SCLCR4		12	1,469	1,250	0,765	1,181	12,000	0°	-10,738°	
A06M-SCLCL2		6	0,48	0,375	0,250	0,336	6,000	0°	-10,696°	CC .. 0602 .. CC .. 2(1.5) ..
A08M-SCLCL2		6	0,598	0,500	0,312	0,460	6,000	0°	-7,86°	
A10R-SCLCL2		6	0,772	0,625	0,406	0,562	8,000	0°	-5,34°	
A10R-SCLCL3		9	0,772	0,625	0,406	0,562	8,000	0°	-8,696°	CC .. 09T3 .. CC .. 3(2.5) ..
A12S-SCLCL3		9	0,929	0,750	0,500	0,709	10,000	0°	-6,371°	
A16T-SCLCL3		9	1,201	1,000	0,640	0,906	12,000	0°	-3,834°	
A16T-SCLCL4		12	1,201	1,000	0,640	0,906	12,000	0°	-5,103°	CC .. 1204 .. CC .. 43 ..
A20T-SCLCL4		12	1,469	1,250	0,765	1,181	12,000	0°	-10,738°	

Dimensional drawing shows right-hand version. | Measured with master insert: CC .. 060204 / CC .. 09T308 / CC .. 120408 | Refer to the Walter online catalogue for more product information: [www.walter-tools.com](http://www.walter-tools.com) | Bodies and assembly parts are included in the scope of delivery

#### Assembly parts

Type $D_{min}$ [inch]	CC .. 0602 .. 0,48	CC .. 0602 .. 0,598–0,772	CC .. 09T3 .. 0,772	CC .. 09T3 .. 0,929–1,201	CC .. 1204 .. 1,201	CC .. 1204 .. 1,469
Clamping screw for indexable insert Tightening torque	FS2066 (T7IP) 0,664 lbs	FS2061 (T7IP) 0,664 lbs	FS2062 (T15IP) 2,213 lbs	FS2063 (T15IP) 2,213 lbs	FS2064 (T15IP) 2,213 lbs	FS2065 (T15IP) 2,213 lbs
Shim						AP314-CC1212
Clamping screw for shim						FS2069 (SW 4)
Torx key	FS1490 (T7IP)	FS1490 (T7IP)	FS1465 (T15IP)	FS1465 (T15IP)	FS1496 (T15IP)	FS1496 (T15IP)

## Boring bar – Screw clamping

### E...-SCLC inch

### Walter Turn



– E = Solid carbide version with internal cooling

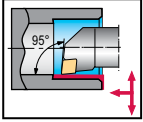

Tool	Designation		D <sub>min</sub> inch	d <sub>1</sub> inch	f inch	l <sub>1</sub> inch	γ	λ <sub>s</sub>	Type
<p>Parallel shank with clamping surface</p>	E06M-SCLCR2	6	0,48	0,375	0,250	6,000	0°	-10,696°	CC .. 0602 .. CC .. 2(1.5) ..
	E08R-SCLCR2	6	0,598	0,500	0,312	8,000	0°	-7,86°	
	E10R-SCLCR2	6	0,772	0,625	0,406	8,000	0°	-5,34°	
	E12S-SCLCR3	9	0,929	0,750	0,500	10,000	0°	-6,371°	CC .. 09T3 .. CC .. 3(2.5) ..
	E16T-SCLCR3	9	1,201	1,000	0,640	12,000	0°	-3,834°	
	E06M-SCLCL2	6	0,48	0,375	0,250	6,000	0°	-10,696°	
	E08R-SCLCL2	6	0,598	0,500	0,312	8,000	0°	-7,86°	CC .. 0602 .. CC .. 2(1.5) ..
	E10R-SCLCL2	6	0,772	0,625	0,406	8,000	0°	-5,34°	
	E12S-SCLCL3	9	0,929	0,750	0,500	10,000	0°	-6,371°	
	E16T-SCLCL3	9	1,201	1,000	0,640	12,000	0°	-3,834°	CC .. 09T3 .. CC .. 3(2.5) ..

Dimensional drawing shows right-hand version. | Measured with master insert: CC .. 060204 / CC .. 09T308 | Refer to the Walter online catalogue for more product information: [www.walter-tools.com](http://www.walter-tools.com) | Bodies and assembly parts are included in the scope of delivery

Assembly parts	Type D <sub>min</sub> [inch]	CC .. 0602 ..	CC .. 0602 ..	CC .. 09T3 ..	CC .. 09T3 ..
		0,48–0,598	0,772	0,929	1,201
<p>Clamping screw for indexable insert Tightening torque</p>		FS2066 (T7IP) 0,664 lbs	FS2061 (T7IP) 0,664 lbs	FS2062 (T15IP) 2,213 lbs	FS2063 (T15IP) 2,213 lbs
<p>Torx key</p>		FS1490 (T7IP)	FS1490 (T7IP)	FS1465 (T15IP)	FS1465 (T15IP)

## Boring bar – Screw clamping

### A...-SCLP inch

### Walter Turn

- A = Steel version with internal cooling
- E = Solid carbide version with internal cooling

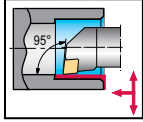

#### Tool

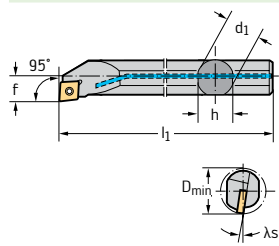

Parallel shank with clamping surface

Designation		$D_{min}$ inch	$d_1$ inch	$f$ inch	$h$ inch	$l_1$ inch	$\gamma$	$\lambda_s$	Type
A05K-SCLPR2	6	0,413	0,312	0,219	0,272	5,000	0°	-9°	CP .. 0602 ..
A06M-SCLPR2	6	0,48	0,375	0,250	0,336	6,000	4°	-6,5°	CP .. 2(1.5) ..
A08M-SCLPR2	6	0,598	0,500	0,312	0,460	6,000	6°	-2,58°	
A10R-SCLPR2	6	0,772	0,625	0,406	0,562	8,000	0°	5°	
A12S-SCLPR3	9	0,929	0,750	0,500	0,709	10,000	0°	-6,3°	CP .. 09T3 ..
A16T-SCLPR3	9	1,201	1,000	0,639	0,906	14,173	6°	1°	CP .. 3(2.5) ..
A05K-SCLPL2	6	0,413	0,312	0,219	0,272	5,000	0°	-9°	CP .. 0602 ..
A06M-SCLPL2	6	0,48	0,375	0,250	0,336	6,000	4°	-6,5°	CP .. 2(1.5) ..
A08M-SCLPL2	6	0,598	0,500	0,312	0,460	6,000	6°	-2,58°	
A10R-SCLPL2	6	0,772	0,625	0,406	0,562	8,000	0°	-5°	
A12S-SCLPL3	9	0,929	0,750	0,500	0,709	10,000	0°	-6,3°	CP .. 09T3 ..
A16T-SCLPL3	9	1,201	1,000	0,639	0,906	14,173	0°	1°	CP .. 3(2.5) ..

Dimensional drawing shows right-hand version. | Measured with master insert: CP .. 060204 / CP .. 09T304 | Refer to the Walter online catalogue for more product information: [www.walter-tools.com](http://www.walter-tools.com) | Bodies and assembly parts are included in the scope of delivery

#### Assembly parts

Type $D_{min}$ (inch)	CP .. 0602 .. 0,413	CP .. 0602 .. 0,48–0,598	CP .. 0602 .. 0,772	CP .. 09T3 .. 0,929	CP .. 09T3 .. 1,201
Clamping screw for indexable insert Tightening torque	FS2187 (T7IP) 0,664 lbs	FS2066 (T7IP) 0,664 lbs	FS2061 (T7IP) 0,664 lbs	FS2062 (T15IP) 2,213 lbs	FS2063 (T15IP) 2,213 lbs
Torx key	FS1490 (T7IP)	FS1490 (T7IP)	FS1490 (T7IP)	FS1465 (T15IP)	FS1465 (T15IP)

## Boring bar – Screw clamping

### E...-SCLP inch

### Walter Turn



– E = Solid carbide version with internal cooling

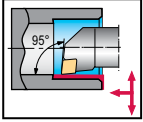

#### Tool

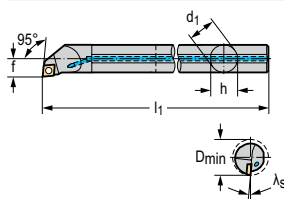



Designation		$D_{min}$ inch	$d_1$ inch	$f$ inch	$l_1$ inch	$\gamma$	$\lambda_s$	Type	
E06M-SCLPR2		6	0,48	0,375	0,250	6,000	4°	-7°	CP .. 0602 ..
E08R-SCLPR2		6	0,598	0,500	0,312	8,000	6°	-3°	CP .. 2(1.5) ..
E06M-SCLPL2		6	0,48	0,375	0,250	6,000	4°	-7°	CP .. 0602 ..
E08R-SCLPL2		6	0,598	0,500	0,312	8,000	6°	-3°	CP .. 2(1.5) ..

Parallel shank with clamping surface

Dimensional drawing shows right-hand version. | Measured with master insert: CP .. 060204 | Refer to the Walter online catalogue for more product information: [www.walter-tools.com](http://www.walter-tools.com) | Bodies and assembly parts are included in the scope of delivery

#### Assembly parts

	Type $D_{min}$ [inch]	CP .. 0602 .. 0,48–0,598
	Clamping screw for indexable insert Tightening torque	FS2066 (T7IP) 0,664 lbs
	Torx key	FS1490 (T7IP)

## Boring bar – Screw clamping

A...-SDQC

### Walter Turn



– A = Steel version with internal cooling

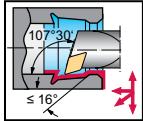

#### Tool

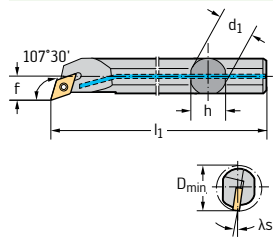

Designation		$D_{min}$ mm	$d_1$ mm	$f$ mm	$h$ mm	$l_1$ mm	$\gamma$	$\lambda_s$	Type
A12M-SDQCR07	7	16	12	9	11	150	0°	-7,1°	DC .. 0702 ..
A16R-SDQCR07	7	20	16	11	15	200	0°	-4,9°	
A20S-SDQCR11	11	25	20	13	18	250	0°	-5,9°	DC .. 11T3 ..
A25T-SDQCR11	11	32	25	17	23	300	0°	-3,5°	
A12M-SDQCL07	7	16	12	9	11	150	0°	-7,1°	DC .. 0702 ..
A16R-SDQCL07	7	20	16	11	15	200	0°	-4,9°	
A20S-SDQCL11	11	25	20	13	18	250	0°	-5,9°	DC .. 11T3 ..
A25T-SDQCL11	11	32	25	17	23	300	0°	-3,5°	

Dimensional drawing shows right-hand version. | Measured with master insert: DC .. 070204 / DC .. 11T308 | Refer to the Walter online catalogue for more product information: [www.walter-tools.com](http://www.walter-tools.com) | Bodies and assembly parts are included in the scope of delivery

#### Assembly parts

Type	Type	DC .. 0702 .. 16–20	DC .. 11T3 .. 25	DC .. 11T3 .. 32
Clamping screw for indexable insert Tightening torque	FS2061 (T7IP) 0,9 Nm	FS2062 (T15IP) 3 Nm	FS2063 (T15IP) 3 Nm	
Torx key	FS1490 (T7IP)	FS1465 (T15IP)	FS1465 (T15IP)	

# Boring bar – Screw clamping

A...-SDQC...-R

## Walter Turn



– A = Steel version with internal cooling

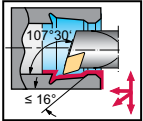

Tool	Designation		$D_{min}$ mm	$d_1$ mm	$f$ mm	$l_1$ mm	$\gamma$	$\lambda_s$	Type
<p>Cylindrical shank</p>	A12M-SDQCR07-R		7	16	9	150	0°	-7,1°	DC .. 0702 ..
	A16R-SDQCR07-R		7	20	11	200	0°	-4,9°	
	A20S-SDQCR11-R		11	25	13	250	0°	-5,9°	DC .. 11T3 ..
	A12M-SDQCL07-R		7	16	9	150	0°	-7,1°	DC .. 0702 ..
	A16R-SDQCL07-R		7	20	11	200	0°	-4,9°	
	A20S-SDQCL11-R		11	25	13	250	0°	-5,9°	DC .. 11T3 ..

Dimensional drawing shows right-hand version. | Measured with master insert: DC .. 070204 / DC .. 11T308 | Refer to the Walter online catalogue for more product information: [www.walter-tools.com](http://www.walter-tools.com) | Bodies and assembly parts are included in the scope of delivery

Assembly parts	Type $D_{min}$ [mm]	DC .. 0702 .. 16–20	DC .. 11T3 .. 25
	Clamping screw for indexable insert Tightening torque	FS2061 (T7IP) 0,9 Nm	FS2062 (T15IP) 3 Nm
	Torx key	FS1490 (T7IP)	FS1465 (T15IP)

## Boring bar – Screw clamping

A...-SDUC

### Walter Turn



– A = Steel version with internal cooling

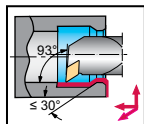

#### Tool

Designation		$D_{min}$ mm	$d_1$ mm	$f$ mm	$h$ mm	$l_1$ mm	$\gamma$	$\lambda_s$	Type
A10K-SDUCR07		7	13	7	9	125	0°	-9°	DC .. 0702 ..
A12M-SDUCR07		7	16	9	11	150	0°	-6,5°	
A16R-SDUCR07		7	20	11	15	200	0°	-4,3°	
A20S-SDUCR11		11	25	13	18	250	0°	-5,8°	DC .. 11T3 ..
A25T-SDUCR11		11	32	17	23	300	0°	-3,4°	
A32T-SDUCR11		11	40	22	30	300	0°	-3°	
A10K-SDUCL07		7	13	7	9	125	0°	-9°	DC .. 0702 ..
A12M-SDUCL07		7	16	9	11	150	0°	-6,5°	
A16R-SDUCL07		7	20	11	15	200	0°	-4,3°	
A20S-SDUCL11		11	25	13	18	250	0°	-5,8°	DC .. 11T3 ..
A25T-SDUCL11		11	32	17	23	300	0°	-3,4°	
A32T-SDUCL11		11	40	22	30	300	0°	-3°	

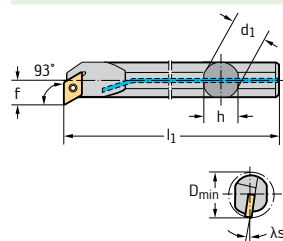

Parallel shank with clamping surface

Dimensional drawing shows right-hand version. | Measured with master insert: DC .. 070204 / DC .. 11T308 | Refer to the Walter online catalogue for more product information: [www.walter-tools.com](http://www.walter-tools.com) | Bodies and assembly parts are included in the scope of delivery

#### Assembly parts

Type $D_{min}$ [mm]	DC .. 0702 .. 13–20	DC .. 11T3 .. 25	DC .. 11T3 .. 32	DC .. 11T3 .. 40
Clamping screw for indexable insert Tightening torque	FS2061 (T7IP) 0,9 Nm	FS2062 (T15IP) 3 Nm	FS2063 (T15IP) 3 Nm	FS2060 (T15IP) 3 Nm
Shim				AP315-DC1108
Clamping screw for shim				FS2068 (SW 3,5)
Torx key	FS1490 (T7IP)	FS1465 (T15IP)	FS1465 (T15IP)	FS1465 (T15IP)



# Boring bar – Screw clamping

A...-SDUC...-R

## Walter Turn



- A = Steel version with internal cooling

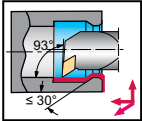

Tool	Designation		$D_{min}$ mm	$d_1$ mm	$f$ mm	$l_1$ mm	$\gamma$	$\lambda_s$	Type
<p>Cylindrical shank</p>	A10K-SDUCR07-R	7	15	10	7	125	0°	-7°	DC .. 0702 ..
	A12M-SDUCR07-R	7	18	12	9	150	0°	-5°	
	A16R-SDUCR07-R	7	20	16	11	200	0°	-4,3°	
	A20S-SDUCR11-R	11	25	20	13	250	0°	-5,8°	DC .. 11T3 ..
	A10K-SDUCL07-R	7	15	10	7	125	0°	-7°	DC .. 0702 ..
	A12M-SDUCL07-R	7	18	12	9	150	0°	-5°	
	A16R-SDUCL07-R	7	20	16	11	200	0°	-4,3°	
	A20S-SDUCL11-R	11	25	20	13	250	0°	-5,8°	DC .. 11T3 ..

Dimensional drawing shows right-hand version. | Measured with master insert: DC .. 070204 / DC .. 11T308 | Refer to the Walter online catalogue for more product information: [www.walter-tools.com](http://www.walter-tools.com) | Bodies and assembly parts are included in the scope of delivery

Assembly parts	Type $D_{min}$ [mm]	DC .. 0702 .. 15-20	DC .. 11T3 .. 25
	Clamping screw for indexable insert Tightening torque	FS2061 (T7IP) 0,9 Nm	FS2062 (T15IP) 3 Nm
	Torx key	FS1490 (T7IP)	FS1465 (T15IP)

## Boring bar – Screw clamping

E...-SDUC...-R 

## Walter Turn



– E = Solid carbide version with internal cooling

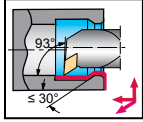

Tool	Designation		$D_{min}$ mm	$d_1$ mm	$f$ mm	$l_1$ mm	$\gamma$	$\lambda_s$	Type
 Cylindrical shank	E10M-SDUCR07-R	7	15	10	9	150	0°	-7,2°	DC .. 0702 ..
	E12Q-SDUCR07-R	7	18	12	11	180	0°	-5,3°	
	E16R-SDUCR07-R	7	22	16	13	200	0°	-3,6°	
	E20S-SDUCR11-R	11	25	20	13	220	0°	-6°	DC .. 11T3 ..
	E25T-SDUCR11-R	11	32	25	17	270	0°	-3°	
	E10M-SDUCL07-R	7	15	10	9	150	0°	-7,2°	DC .. 0702 ..
	E12Q-SDUCL07-R	7	18	12	11	180	0°	-5,3°	
	E16R-SDUCL07-R	7	22	16	13	200	0°	-3,6°	
	E20S-SDUCL11-R	11	25	20	13	220	0°	-6°	DC .. 11T3 ..
	E25T-SDUCL11-R	11	32	25	17	270	0°	-3°	

Dimensional drawing shows right-hand version. | Measured with master insert: DC .. 070204 / DC .. 11T308 | Refer to the Walter online catalogue for more product information: [www.walter-tools.com](http://www.walter-tools.com) | Bodies and assembly parts are included in the scope of delivery

Assembly parts	Type $D_{min}$ [mm]	DC .. 0702 .. 15–22	DC .. 11T3 .. 25	DC .. 11T3 .. 32
 Clamping screw for indexable insert Tightening torque		FS2061 (T7IP) 0,9 Nm	FS2062 (T15IP) 3 Nm	FS2063 (T15IP) 3 Nm
 Torx key		FS1490 (T7IP)	FS1465 (T15IP)	FS1465 (T15IP)

## Boring bar – Screw clamping

A...-SDUC...-X

### Walter Turn

- A = Steel version with internal cooling
- Reverse copy boring bar

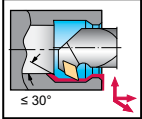

#### Tool

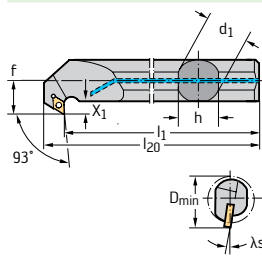

Designation



$D_{min}$   
mm

$d_1$   
mm

f  
mm

h  
mm

$l_1$   
mm

$l_{20}$   
mm

$\gamma$

$\lambda_s$

Type

A16R-SDUCR07-X	7	22	16	13	15	200	212,2	0°	-3,6°	DC .. 0702 ..
A20S-SDUCR07-X	7	27	20	15	18	250	262,2	0°	-2,1°	
A25T-SDUCR07-X	7	33	25	18	23	300	312,2	0°	-0,9°	
A32T-SDUCR11-X	11	40	32	22	30	300	316,7	0°	-7,6°	DC .. 11T3 ..
A16R-SDUCL07-X	7	22	16	13	15	200	212,2	0°	-3,6°	DC .. 0702 ..
A20S-SDUCL07-X	7	27	20	15	18	250	262,2	0°	-2,1°	
A25T-SDUCL07-X	7	33	25	18	23	300	312,2	0°	-0,9°	
A32T-SDUCL11-X	11	40	32	22	30	300	316,7	0°	-7,6°	DC .. 11T3 ..

Parallel shank with clamping surface

Dimensional drawing shows right-hand version. | Measured with master insert: DC .. 070204 / DC .. 11T308 |  $X_1 = f - d_1/2$  | Refer to the Walter online catalogue for more product information: [www.walter-tools.com](http://www.walter-tools.com) | Bodies and assembly parts are included in the scope of delivery

#### Assembly parts

	Type $D_{min}$ [mm]	DC .. 0702 .. 22-33	DC .. 11T3 .. 40
	Clamping screw for indexable insert Tightening torque	FS2061 (T7IP) 0,9 Nm	FS2060 (T15IP) 3 Nm
	Shim		AP315-DC1108
	Screw for shim		FS2068 (SW 3,5)
	Torx key	FS1490 (T7IP)	FS1465 (T15IP)

## Boring bar – Screw clamping

### A...-SDUC inch

### Walter Turn



– A = Steel version with internal cooling

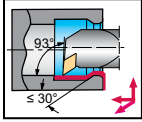

#### Tool

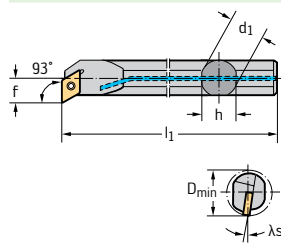

Parallel shank with clamping surface

Designation		$D_{min}$ inch	$d_1$ inch	$f$ inch	$h$ inch	$l_1$ inch	$\gamma$	$\lambda_s$	Type
A06M-SDUCR2	7	0,598	0,375	0,375	0,336	6,000	0°	-7,06°	DC .. 0702 ..
A08M-SDUCR2	7	0,728	0,500	0,438	0,460	6,000	0°	-5,018°	DC .. 2(1.5) ..
A10R-SDUCR2	7	0,85	0,625	0,500	0,562	8,000	0°	-3,698°	
A12S-SDUCR3	11	1,051	0,750	0,625	0,709	10,000	0°	-5,076°	DC .. 11T3 ..
A16T-SDUCR3	11	1,299	1,000	0,750	0,906	12,000	0°	-3,161°	DC .. 3(2.5) ..
A06M-SDUCL2	7	0,598	0,375	0,375	0,336	6,000	0°	-7,06°	DC .. 0702 ..
A08M-SDUCL2	7	0,728	0,500	0,438	0,460	6,000	0°	-5,018°	DC .. 2(1.5) ..
A10R-SDUCL2	7	0,85	0,625	0,500	0,562	8,000	0°	-3,698°	
A12S-SDUCL3	11	1,051	0,750	0,625	0,709	10,000	0°	-5,076°	DC .. 11T3 ..
A16T-SDUCL3	11	1,299	1,000	0,750	0,906	12,000	0°	-3,161°	DC .. 3(2.5) ..

Dimensional drawing shows right-hand version. | Measured with master insert: DC .. 070204 / DC .. 11T308 | Refer to the Walter online catalogue for more product information: [www.walter-tools.com](http://www.walter-tools.com) | Bodies and assembly parts are included in the scope of delivery

#### Assembly parts

	Type $D_{min}$ (inch)	DC .. 0702 .. 0,598–0,85	DC .. 11T3 .. 1,051–1,299
	Clamping screw for indexable insert Tightening torque	FS2061 (T7IP) 0,664 lbs	FS2062 (T15IP) 2,213 lbs
	Torx key	FS1490 (T7IP)	FS1465 (T15IP)

# Boring bar – Screw clamping

E...-SDUC inch

**Walter Turn**



– E = Solid carbide version with internal cooling

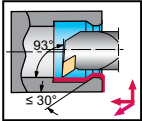

Tool	Designation		D <sub>min</sub> inch	d <sub>1</sub> inch	f inch	h inch	l <sub>1</sub> inch	γ	λ <sub>s</sub>	Type
<p>Parallel shank with clamping surface</p>	E06M-SDUCR2	7	0,598	0,375	0,375	0,336	6,000	0°	-7°	DC .. 0702 .. DC .. 2(1.5) ..
	E08R-SDUCR2	7	0,717	0,500	0,438	0,460	8,000	0°	-5°	
	E10R-SDUCR2	7	0,85	0,625	0,500	0,354	8,000	0°	-4°	
	E12S-SDUCR3	11	1,039	0,750	0,625	0,709	10,000	0°	-3°	DC .. 11T3 .. DC .. 3(2.5) ..
	E16T-SDUCR3	11	1,299	1,000	0,750	0,906	12,000	0°	-3°	
	E06M-SDUCL2	7	0,598	0,375	0,375	0,336	6,000	0°	-7°	
	E08R-SDUCL2	7	0,717	0,500	0,438	0,460	8,000	0°	-5°	
	E10R-SDUCL2	7	0,85	0,625	0,500	0,354	8,000	0°	-4°	
	E12S-SDUCL3	11	1,039	0,750	0,625	0,709	10,000	0°	-3°	DC .. 11T3 .. DC .. 3(2.5) ..
	E16T-SDUCL3	11	1,299	1,000	0,750	0,906	12,000	0°	-3°	

Dimensional drawing shows right-hand version. | Measured with master insert: DC .. 070204 / DC .. 11T308 | Refer to the Walter online catalogue for more product information: [www.walter-tools.com](http://www.walter-tools.com) | Bodies and assembly parts are included in the scope of delivery

Assembly parts	Type D <sub>min</sub> [inch]	DC .. 0702 ..	DC .. 11T3 ..	DC .. 11T3 ..
		0,598–0,85	1,039	1,299
	Clamping screw for indexable insert Tightening torque	FS2061 (T7IP) 0,664 lbs	FS2062 (T15IP) 2,213 lbs	FS2063 (T15IP) 2,213 lbs
	Torx key	FS1490 (T7IP)	FS1465 (T15IP)	FS1465 (T15IP)

## Boring bar – Screw clamping

### A...-SDUC...-X inch

### Walter Turn

- A = Steel version with internal cooling
- Reverse copy boring bar

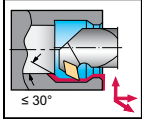

#### Tool

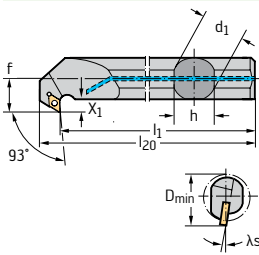

Designation		$D_{min}$ inch	$d_1$ inch	$f$ inch	$h$ inch	$l_1$ inch	$l_{20}$ inch	$\gamma$	$\lambda_s$	Type
A16T-SDUCR2-X	7	1,299	1,000	0,750	0,906	12,000	12,48	0°	-0,9°	DC .. 0702 .. DC .. 2(1.5) ..
A20T-SDUCR3-X	11	1,579	1,250	0,875	1,181	12,000	12,61	0°	-7,528°	DC .. 11T3 .. DC .. 3(2.5) ..
A16T-SDUCL2-X	7	1,299	1,000	0,750	0,906	12,000	12,48	0°	0,9°	DC .. 0702 .. DC .. 2(1.5) ..
A20T-SDUCL3-X	11	1,579	1,250	0,875	1,181	12,000	12,61	0°	-7,528°	DC .. 11T3 .. DC .. 3(2.5) ..

Parallel shank with clamping surface

Dimensional drawing shows right-hand version. | Measured with master insert: DC .. 070204 / DC .. 11T308 | Refer to the Walter online catalogue for more product information: [www.walter-tools.com](http://www.walter-tools.com) | Bodies and assembly parts are included in the scope of delivery

#### Assembly parts

	Type $D_{min}$ [inch]	DC .. 0702 .. 1,299	DC .. 11T3 .. 1,579
	Clamping screw for indexable insert Tightening torque	FS2061 (T7IP) 0,664 lbs	FS2062 (T15IP) 2,213 lbs
	Torx key	FS1490 (T7IP)	FS1465 (T15IP)

## Boring bar – Screw clamping

A...-SDJC

### Walter Turn

- A = Steel version with internal cooling
- Additional coolant hole for blind hole machining

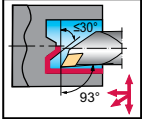

#### Tool

	Designation		D <sub>min</sub> mm	d <sub>1</sub> mm	f mm	h mm	l <sub>1</sub> mm	γ	λ <sub>s</sub>	Type	
										Type	
	A16R-SDJCR07		7	20	16	9	15	200	0°	-6°	DC .. 0702 ..
	A20S-SDJCR11		11	25	20	12	18	250	0°	-6°	DC .. 11T3 ..
	A25T-SDJCR11		11	32	25	14	23	300	0°	-4°	
	A16R-SDJCL07		7	20	16	9	15	200	0°	-6°	DC .. 0702 ..
	A20S-SDJCL11		11	25	20	12	18	250	0°	-6°	DC .. 11T3 ..
	A25T-SDJCL11		11	32	25	14	23	300	0°	-4°	

Parallel shank with clamping surface

Dimensional drawing shows right-hand version. | Measured with master insert: DC .. 070204 / DC .. 11T308 | Refer to the Walter online catalogue for more product information: [www.walter-tools.com](http://www.walter-tools.com) | Bodies and assembly parts are included in the scope of delivery

#### Assembly parts

	Type D <sub>min</sub> [mm]	DC .. 0702 .. 20	DC .. 11T3 .. 25-32
	Clamping screw for indexable insert Tightening torque	FS2061 (T7IP) 0,9 Nm	FS2062 (T15IP) 3 Nm
	Torx key	FS1490 (T7IP)	FS1465 (T15IP)

## Boring bar – Screw clamping

A...-SDXC...

### Walter Turn

- A = Steel version with internal cooling
- Forwards/reverse copy boring bar

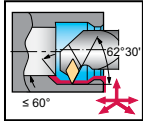

#### Tool

Designation		$D_{min}$ mm	$d_1$ mm	$f$ mm	$h$ mm	$l_1$ mm	$l_{20}$ mm	$\gamma$	$\lambda_s$	Type	
A12M-SDXCR07		7	16	12	9	11	154,3	0°	-4°	DC .. 0702 ..	
A16R-SDXCR07		7	20	16	11	15	200	-2°	-4°	DC .. 11T3 ..	
A20S-SDXCR11		11	25	20	13	18	250	-3°	-5,8°		
A25T-SDXCR11		11	32	25	17	23	300	-2°	-3,4°		
A12M-SDXCL07		7	16	12	9	11	150	154,3	0°	-4°	DC .. 0702 ..
A16R-SDXCL07		7	20	16	11	15	200	205	-2°	-4°	DC .. 11T3 ..
A20S-SDXCL11		11	25	20	13	18	250	257	-3°	-5,8°	
A25T-SDXCL11		11	32	25	17	23	300	306	-2°	-3,4°	

Parallel shank with clamping surface

Dimensional drawing shows right-hand version. | Measured with master insert: DC .. 070204 / DC .. 11T308 |  $X_1 = f - d_1/2$  | Refer to the Walter online catalogue for more product information: [www.walter-tools.com](http://www.walter-tools.com) | Bodies and assembly parts are included in the scope of delivery

#### Assembly parts

Type	Type	DC .. 0702 .. 16-20	DC .. 11T3 .. 25	DC .. 11T3 .. 32
 Clamping screw for indexable insert Tightening torque		FS2061 (T7IP) 0,9 Nm	FS2062 (T15IP) 3 Nm	FS2063 (T15IP) 3 Nm
 Torx key		FS1490 (T7IP)	FS1465 (T15IP)	FS1465 (T15IP)



## Boring bar – Screw clamping

A...-SSKC

### Walter Turn



– A = Steel version with internal cooling

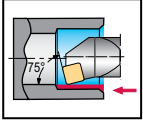

Tool	Designation		D <sub>min</sub> mm	d <sub>1</sub> mm	f mm	h mm	l <sub>1</sub> mm	γ	λ <sub>s</sub>	Type	
	A16R-SSKCR09		9	20	16	11	15	200	0°	-8,9°	SC .. 09T3 ..
	A20S-SSKCR09		9	25	20	13	18	250	0°	-6°	
	A25T-SSKCR12		12	32	25	17	23	300	0°	-4,7°	SC .. 1204 ..
	A16R-SSKCL09		9	20	16	11	15	200	0°	-8,9°	SC .. 09T3 ..
	A20S-SSKCL09		9	25	20	13	18	250	0°	-6°	
	A25T-SSKCL12		12	32	25	17	23	300	0°	-4,7°	SC .. 1204 ..

Parallel shank with clamping surface

Dimensional drawing shows right-hand version. | Measured with master insert: SC .. 09T308 / SC .. 120408 | Refer to the Walter online catalogue for more product information: [www.walter-tools.com](http://www.walter-tools.com) | Bodies and assembly parts are included in the scope of delivery

Assembly parts	Type D <sub>min</sub> [mm]	SC .. 09T3 .. 20–25	SC .. 1204 .. 32
			Clamping screw for indexable insert Tightening torque
	Torx key	FS1465 (T15IP)	FS1496 (T15IP)

## Boring bar – Screw clamping

A...-STFC

### Walter Turn



– A = Steel version with internal cooling

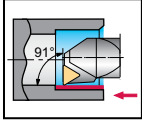

#### Tool

Designation		$D_{min}$ mm	$d_1$ mm	$f$ mm	$h$ mm	$l_1$ mm	$\gamma$	$\lambda_s$	Type
A06F-STFCR06	6	9	6	5	5	80	0°	-12,2°	TC .. 06T1 ..
A08H-STFCR06	6	11	8	6	7	100	0°	-10,2°	
A10K-STFCR09	9	13	10	7	9	125	0°	-9,2°	TC .. 0902 ..
A12M-STFCR11	11	16	12	9	11	150	0°	-6,7°	TC .. 1102 ..
A16R-STFCR11	11	20	16	11	15	200	0°	-4,5°	
A20S-STFCR11	11	25	20	13	18	250	0°	-2,8°	
A25T-STFCR16	16	32	25	17	23	300	0°	-3,4°	TC .. 16T3 ..
A32T-STFCR16	16	40	32	22	30	300	0°	-7,9°	
A06F-STFCL06	6	9	6	5	5	80	0°	-12,2°	TC .. 06T1 ..
A08H-STFCL06	6	11	8	6	7	100	0°	-10,2°	
A10K-STFCL09	9	13	10	7	9	125	0°	-9,2°	TC .. 0902 ..
A12M-STFCL11	11	16	12	9	11	150	0°	-6,7°	TC .. 1102 ..
A16R-STFCL11	11	20	16	11	15	200	0°	-4,5°	
A20S-STFCL11	11	25	20	13	18	250	0°	-2,8°	
A25T-STFCL16	16	32	25	17	23	300	0°	-3,4°	TC .. 16T3 ..
A32T-STFCL16	16	40	32	22	30	300	0°	-7,9°	

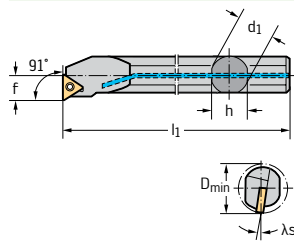

Parallel shank with clamping surface

Dimensional drawing shows right-hand version. | Measured with master insert: TC .. 06T102 / TC .. 090204 / TC .. 110204 / TC .. 16T308 | Refer to the Walter online catalogue for more product information: [www.walter-tools.com](http://www.walter-tools.com) | Bodies and assembly parts are included in the scope of delivery

#### Assembly parts

Type $D_{min}$ [mm]	TC .. 06T1 .. 9	TC .. 06T1 .. 11	TC .. 0902 .. 13	TC .. 1102 .. 16	TC .. 1102 .. 20–25	TC .. 16T3 .. 32	TC .. 16T3 .. 40
Clamping screw for indexable insert Tightening torque	FS2147 (T6IP) 0,6 Nm	FS2148 (T6IP) 0,6 Nm	FS2149 (T7IP) 0,9 Nm	FS2067 (T7IP) 0,9 Nm	FS2061 (T7IP) 0,9 Nm	FS2063 (T15IP) 3 Nm	FS2060 (T15IP) 3 Nm
Shim							AP317- TC1612
Screw for shim							FS2068 (SW 3,5)
Torx key	FS2146 (T6IP)	FS2146 (T6IP)	FS1490 (T7IP)	FS1490 (T7IP)	FS1490 (T7IP)	FS1465 (T15IP)	FS1465 (T15IP)

## Boring bar – Screw clamping

A...-STFC...-R

### Walter Turn



– A = Steel version with internal cooling

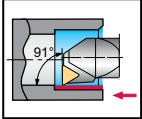

#### Tool

	Designation		$D_{min}$ mm	$d_1$ mm	$f$ mm	$l_1$ mm	$\gamma$	$\lambda_s$	Type
 Cylindrical shank	A06F-STFCR06-R		6	9	5	80	0°	-12,2°	TC .. 06T1 ..
	A08H-STFCR06-R		6	11	6	100	0°	-10,2°	
	A10K-STFCR09-R		9	13	7	125	0°	-9,2°	TC .. 0902 ..
	A12M-STFCR11-R		11	16	9	150	0°	-6,5°	TC .. 1102 ..
	A16R-STFCR11-R		11	20	11	200	0°	-4,5°	
	A06F-STFCL06-R		6	9	5	80	0°	-12,2°	TC .. 06T1 ..
	A08H-STFCL06-R		6	11	6	100	0°	-10,2°	
	A10K-STFCL09-R		9	13	7	125	0°	-9,2°	TC .. 0902 ..
	A12M-STFCL11-R		11	16	9	150	0°	-6,5°	TC .. 1102 ..
	A16R-STFCL11-R		11	20	11	200	0°	-4,5°	

Dimensional drawing shows right-hand version. | Measured with master insert: TC .. 06T102 / TC .. 090204 / TC .. 110204 | Refer to the Walter online catalogue for more product information: [www.walter-tools.com](http://www.walter-tools.com) | Bodies and assembly parts are included in the scope of delivery

#### Assembly parts

Type $D_{min}$ [mm]	TC .. 06T1 .. 9	TC .. 06T1 .. 11	TC .. 0902 .. 13	TC .. 1102 .. 16	TC .. 1102 .. 20
 Clamping screw for indexable insert Tightening torque	FS2147 (T6IP) 0,6 Nm	FS2148 (T6IP) 0,6 Nm	FS2149 (T7IP) 0,9 Nm	FS2067 (T7IP) 0,9 Nm	FS2061 (T7IP) 0,9 Nm
 Torx key	FS2146 (T6IP)	FS2146 (T6IP)	FS1490 (T7IP)	FS1490 (T7IP)	FS1490 (T7IP)

## Boring bar – Screw clamping

E...-STFC...-R

Walter Turn



– E = Solid carbide version with internal cooling

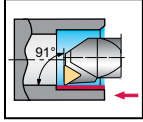

### Tool

Tool	Designation		D <sub>min</sub> mm	d <sub>1</sub> mm	f mm	l <sub>1</sub> mm	γ	λ <sub>s</sub>	Type
 Cylindrical shank	E06H-STFCR06-R	6	9	6	5	100	0°	-12,2°	TC .. 06T1 ..
	E08K-STFCR06-R	6	11	8	6	125	0°	-10,2°	
	E10M-STFCR09-R	9	13	10	7	150	0°	-9,2°	TC .. 0902 ..
	E12Q-STFCR09-R	9	16	12	9	180	0°	-6,7°	
	E16R-STFCL11-R	11	20	16	11	200	0°	-4°	TC .. 1102 ..
	E20S-STFCL11-R	11	25	20	13	220	0°	-3°	
	E25T-STFCR16-R	16	32	25	17	270	0°	-3°	TC .. 16T3 ..
	E06H-STFCL06-R	6	9	6	5	100	0°	-12,2°	
	E08K-STFCL06-R	6	11	8	6	125	0°	-10,2°	TC .. 0902 ..
	E10M-STFCL09-R	9	13	10	7	150	0°	-9,2°	
	E12Q-STFCL09-R	9	16	12	9	180	0°	-6,7°	TC .. 1102 ..
	E16R-STFCL11-R	11	20	16	11	200	0°	-4°	
	E20S-STFCL11-R	11	25	20	13	220	0°	-3°	TC .. 16T3 ..
	E25T-STFCL16-R	16	32	25	17	270	0°	-3°	

Dimensional drawing shows right-hand version. | Measured with master insert: TC .. 06T102 / TC .. 090204 / TC .. 110204 / TC .. 16T308 | Refer to the Walter online catalogue for more product information: [www.walter-tools.com](http://www.walter-tools.com) | Bodies and assembly parts are included in the scope of delivery

### Assembly parts

Type	TC .. 06T1 .. 9	TC .. 06T1 .. 11	TC .. 0902 .. 13–16	TC .. 1102 .. 20–25	TC .. 16T3 .. 32
 Clamping screw for indexable insert Tightening torque	FS2147 (T6IP) 0,6 Nm	FS2148 (T6IP) 0,6 Nm	FS2149 (T7IP) 0,9 Nm	FS2061 (T7IP) 0,9 Nm	FS2063 (T15IP) 3 Nm
 Torx key	FS2146 (T6IP)	FS2146 (T6IP)	FS1490 (T7IP)	FS1490 (T7IP)	FS1465 (T15IP)

## Boring bar – Screw clamping

### A...-STFC inch

### Walter Turn



– A = Steel version with internal cooling

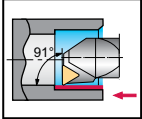

#### Tool

Designation		D <sub>min</sub> inch	d <sub>1</sub> inch	f inch	h inch	l <sub>1</sub> inch	γ	λ <sub>s</sub>	Type
A06M-STFCR2	11	0,500	0,375	0,250	0,336	6,000	0°	-10,075°	TC .. 1102 ..
A08M-STFCR2	11	0,598	0,500	0,312	0,460	6,000	0°	-7,213°	TC .. 2(1.5) ..
A10R-STFCR2	11	0,772	0,625	0,406	0,562	8,000	0°	-4,703°	
A12S-STFCR2	11	0,929	0,750	0,500	0,709	10,000	0°	-3,161°	
A16T-STFCR3	16	1,201	1,000	0,640	0,906	12,000	0°	-3,834°	TC .. 16T3 ..
A20T-STFCR3	16	1,469	1,250	0,765	1,181	12,000	0°	-8,67°	TC .. 3(2.5) ..
A06M-STFCL2	11	0,500	0,375	0,250	0,336	6,000	0°	-10,075°	TC .. 1102 ..
A08M-STFCL2	11	0,598	0,500	0,312	0,460	6,000	0°	-7,213°	TC .. 2(1.5) ..
A10R-STFCL2	11	0,772	0,625	0,406	0,562	8,000	0°	-4,703°	
A12S-STFCL2	11	0,929	0,750	0,500	0,709	10,000	0°	-3,161°	
A16T-STFCL3	16	1,201	1,000	0,640	0,906	12,000	0°	-3,834°	TC .. 16T3 ..
A20T-STFCL3	16	1,469	1,250	0,765	1,181	12,000	0°	-8,67°	TC .. 3(2.5) ..

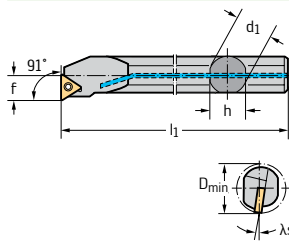

Parallel shank with clamping surface

Dimensional drawing shows right-hand version. | Measured with master insert: TC .. 110204 / TC .. 16T308 | Refer to the Walter online catalogue for more product information: [www.walter-tools.com](http://www.walter-tools.com) | Bodies and assembly parts are included in the scope of delivery

#### Assembly parts

Type	Type	TC .. 1102 .. 0,5–0,598	TC .. 1102 .. 0,772–0,929	TC .. 16T3 .. 1,201	TC .. 16T3 .. 1,469
	Clamping screw for indexable insert Tightening torque	FS2067 (T7IP) 0,664 lbs	FS2061 (T7IP) 0,664 lbs	FS2063 (T15IP) 2,213 lbs	FS2060 (T15IP) 2,213 lbs
	Shim				AP317-TC1612
	Clamping screw for shim				FS2068 (SW 3,5)
	Torx key	FS1490 (T7IP)	FS1490 (T7IP)	FS1465 (T15IP)	FS1465 (T15IP)

## Boring bar – Screw clamping

### E...-STFC inch

### Walter Turn



– E = Solid carbide version with internal cooling

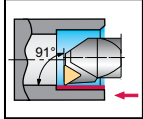

#### Tool

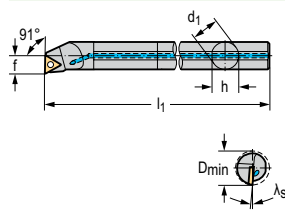

Parallel shank with clamping surface

Designation		$D_{min}$ inch	$d_1$ inch	$f$ inch	$h$ inch	$l_1$ inch	$\gamma$	$\lambda_s$	Type
E06M-STFCR1.8	9	0,500	0,375	0,264	0,359	6,000	0°	-9,5°	TC .. 0902 .. TC .. 1.8(1.5) ..
E08R-STFCR1.8	9	0,630	0,500	0,349	0,460	8,000	0°	-7°	
E10R-STFCR2	11	0,772	0,625	0,406	0,609	8,000	0°	-6°	TC .. 1102 .. TC .. 2(1.5) ..
E12S-STFCR2	11	0,929	0,750	0,500	0,734	10,000	0°	-4°	
E16T-STFCR3	16	1,201	1,000	0,640	0,984	12,000	0°	-4°	TC .. 16T3 .. TC .. 3(2.5) ..
E06M-STFCL1.8	9	0,500	0,375	0,264	0,359	6,000	0°	-9,5°	TC .. 0902 .. TC .. 1.8(1.5) ..
E08R-STFCL1.8	9	0,630	0,500	0,349	0,460	8,000	0°	-7°	
E10R-STFCL2	11	0,772	0,625	0,406	0,609	8,000	0°	-6°	TC .. 1102 .. TC .. 2(1.5) ..
E12S-STFCL2	11	0,929	0,750	0,500	0,734	10,000	0°	-4°	
E16T-STFCL3	16	1,201	1,000	0,640	0,984	12,000	0°	-4°	TC .. 16T3 .. TC .. 3(2.5) ..

Dimensional drawing shows right-hand version. | Measured with master insert: TC .. 090204 / TC .. 110200RE=0 / TC .. 16T308 | Refer to the Walter online catalogue for more product information: [www.walter-tools.com](http://www.walter-tools.com) | Bodies and assembly parts are included in the scope of delivery

#### Assembly parts

Type	Type	TC .. 0902 .. 0,5–0,63	TC .. 1102 .. 0,772–0,929	TC .. 16T3 .. 1,201
Clamping screw for indexable insert Tightening torque	FS2149 (T7IP)	FS2061 (T7IP)	FS2063 (T15IP)	
	0,664 lbs	0,664 lbs	2,213 lbs	
Torx key	FS1490 (T7IP)	FS1490 (T7IP)	FS1465 (T15IP)	

## Boring bar – Screw clamping

A...-SVQB 

## Walter Turn



– A = Steel version with internal cooling

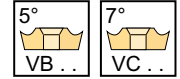
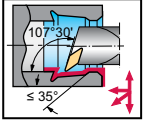

## Tool

Designation		$D_{\min}$ mm	$d_1$ mm	$f$ mm	$h$ mm	$l_1$ mm	$\gamma$	$\lambda_s$	Type
A16R-SVQBR11		11	22	16	13	15	0°	-6,9°	VB .. 1103 ..
A20S-SVQBR11		11	27	20	15	18	0°	-5°	
A25T-SVQBR11		11	33	25	18	23	0°	-3,5°	
A32T-SVQBR16		16	40	32	22	30	0°	-10,9°	VB .. 1604 ..
A40T-SVQBR16		16	50	40	27	37	0°	-7,9°	
A16R-SVQBL11		11	22	16	13	15	0°	-6,9°	VB .. 1103 ..
A20S-SVQBL11		11	27	20	15	18	0°	-5°	
A25T-SVQBL11		11	33	25	18	23	0°	-3,5°	
A32T-SVQBL16		16	40	32	22	30	0°	-10,9°	VB .. 1604 ..
A40T-SVQBL16		16	50	40	27	37	0°	-7,9°	

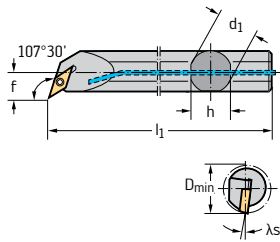

Parallel shank with clamping surface

Dimensional drawing shows right-hand version. | Measured with master insert: VB .. 110304 / VB .. 160408 | Refer to the Walter online catalogue for more product information: [www.walter-tools.com](http://www.walter-tools.com) | Bodies and assembly parts are included in the scope of delivery

## Assembly parts

	Type $D_{\min}$ [mm]	VB .. 1103 .. 22–33	VB .. 1604 .. 40–50
	Clamping screw for indexable insert Tightening torque	FS2172 (T71P) 0,9 Nm	FS2060 (T151P) 3 Nm
	Shim		AP316-VB1608
	Screw for shim		FS2068 (SW 3,5)
	Torx key	FS1490 (T71P)	FS1465 (T151P)

## Boring bar – Screw clamping

A...-SVQB...-R

### Walter Turn



– A = Steel version with internal cooling

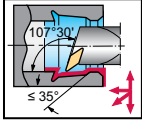

#### Tool

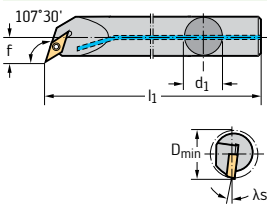

Cylindrical shank

Designation		$D_{min}$ mm	$d_1$ mm	$f$ mm	$l_1$ mm	$\gamma$	$\lambda_s$	Type
A16R-SVQBR11-R	11	22	16	13	200	0°	-6,9°	VB .. 1103 ..
A20S-SVQBR11-R	11	27	20	15	250	0°	-5°	
A16R-SVQBL11-R	11	22	16	13	200	0°	-6,9°	VB .. 1103 ..
A20S-SVQBL11-R	11	27	20	15	250	0°	-5°	

Dimensional drawing shows right-hand version. | Measured with master insert: VB .. 110304 | Refer to the Walter online catalogue for more product information: [www.walter-tools.com](http://www.walter-tools.com) | Bodies and assembly parts are included in the scope of delivery

#### Assembly parts

Type	$D_{min}$ [mm]	VB .. 1103 .. 22–27
Clamping screw for indexable insert Tightening torque		FS2172 (T7IP) 0,9 Nm
	Torx key	FS1490 (T7IP)



# Boring bar – Screw clamping

A...-SVJB

## Walter Turn

- A = Steel version with internal cooling
- Additional coolant hole for blind hole machining

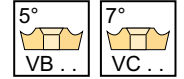
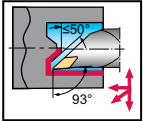

### Tool

	Designation		$D_{min}$ mm	$d_1$ mm	$f$ mm	$h$ mm	$l_1$ mm	$\gamma$	$\lambda_s$	Type
	A16R-SVJBR11	11	20	16	9	15	200	0°	-6°	VB .. 1103 ..
	A20S-SVJBR11	11	25	20	11	18	250	0°	-6°	
	A16R-SVJBL11	11	20	16	9	15	200	0°	-6°	VB .. 1103 ..
	A20S-SVJBL11	11	25	20	11	18	250	0°	-6°	

Parallel shank with clamping surface

Dimensional drawing shows right-hand version. | Measured with master insert: VB .. 110304 | Refer to the Walter online catalogue for more product information: [www.walter-tools.com](http://www.walter-tools.com) | Bodies and assembly parts are included in the scope of delivery

### Assembly parts

Type	VB .. 1103 .. 20	VB .. 1103 .. 25
Clamping screw for indexable insert Tightening torque	FS2067 (T7IP) 0,9 Nm	FS2172 (T7IP) 0,9 Nm
Torx key	FS1490 (T7IP)	FS1490 (T7IP)

## Boring bar – Screw clamping

A...-SVUB

### Walter Turn



– A = Steel version with internal cooling

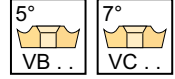
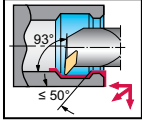

#### Tool

Designation		$D_{min}$ mm	$d_1$ mm	$f$ mm	$h$ mm	$l_1$ mm	$\gamma$	$\lambda_s$	Type
A16R-SVUBR11		11	22	16	13	15	0°	-6,5°	VB .. 1103 ..
A20S-SVUBR11		11	27	20	15	18	0°	-4,7°	
A25T-SVUBR11		11	33	25	18	23	0°	-3,3°	
A32T-SVUBR16		16	40	32	22	30	0°	-9,8°	VB .. 1604 ..
A40T-SVUBR16		16	50	40	27	37	0°	-6,9°	
A16R-SVUBL11		11	22	16	13	15	0°	-6,5°	VB .. 1103 ..
A20S-SVUBL11		11	27	20	15	18	0°	-4,7°	
A25T-SVUBL11		11	33	25	18	23	0°	-3,3°	
A32T-SVUBL16		16	40	32	22	30	0°	-9,8°	VB .. 1604 ..
A40T-SVUBL16		16	50	40	27	37	0°	-6,9°	

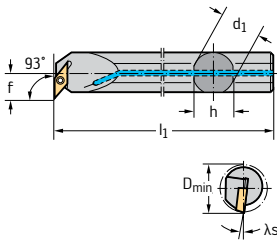

Parallel shank with clamping surface

Dimensional drawing shows right-hand version. | Measured with master insert: VB .. 110304 / VB .. 160408 | Refer to the Walter online catalogue for more product information: [www.walter-tools.com](http://www.walter-tools.com) | Bodies and assembly parts are included in the scope of delivery

#### Assembly parts

Type $D_{min}$ [mm]	VB .. 1103 .. 22–33	VB .. 1604 .. 40–50
Clamping screw for indexable insert Tightening torque	FS2172 (T7IP) 0,9 Nm	FS2060 (T15IP) 3 Nm
Shim		AP316-VB1608
Screw for shim		FS2068 (SW 3,5)
Torx key	FS1490 (T7IP)	FS1465 (T15IP)

# Boring bar – Screw clamping

A...-SVUB...-R

## Walter Turn



- A = Steel version with internal cooling

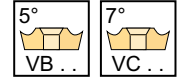
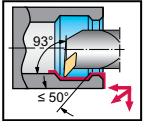

Tool		Designation		$D_{min}$ mm	$d_1$ mm	$f$ mm	$l_1$ mm	$\gamma$	$\lambda_s$	Type
		A16R-SVUBR11-R	11	22	16	13	200	0°	-6,5°	VB .. 1103 ..
		A20S-SVUBR11-R	11	27	20	15	250	0°	-4,6°	
		A16R-SVUBL11-R	11	22	16	13	200	0°	-6,5°	VB .. 1103 ..
		A20S-SVUBL11-R	11	27	20	15	250	0°	-4,6°	

Cylindrical shank

Dimensional drawing shows right-hand version. | Measured with master insert: VB .. 110304 | Refer to the Walter online catalogue for more product information: [www.walter-tools.com](http://www.walter-tools.com) | Bodies and assembly parts are included in the scope of delivery

Assembly parts		Type	VB .. 1103 ..
		$D_{min}$ [mm]	22-27
	Clamping screw for indexable insert		FS2172 (T7IP)
	Tightening torque		0,9 Nm
	Torx key		FS1490 (T7IP)

## Boring bar – Screw clamping

A...-SVUB inch

Walter Turn

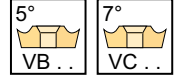
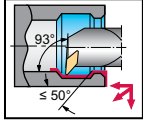

## Tool

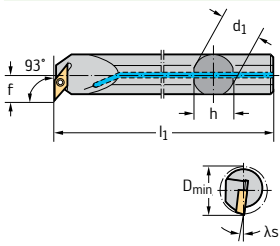

Parallel shank with clamping surface

Designation		$D_{min}$ inch	$d_1$ inch	$f$ inch	$h$ inch	$l_1$ inch	$\gamma$	$\lambda_s$	Type
A10R-SVUBR2	11	0,85	0,625	0,486	0,562	8,000	0°	-6,839°	VB .. 1103 .. VB .. 22 ..
A12S-SVUBR2	11	1,012	0,750	0,580	0,709	10,000	0°	-5,05°	
A16T-SVUBR2	11	1,24	1,000	0,680	0,906	12,000	0°	-3,519°	
A20T-SVUBR3	16	1,705	1,250	1,000	1,181	12,000	0°	-8,696°	VB .. 1604 .. VB .. 33 ..
A24T-SVUBR3	16	2,126	1,500	1,125	1,374	12,000	0°	-5,997°	
A10R-SVUBL2	11	0,85	0,625	0,486	0,562	8,000	0°	-6,839°	VB .. 1103 .. VB .. 22 ..
A12S-SVUBL2	11	1,012	0,750	0,580	0,709	10,000	0°	-5,05°	
A16T-SVUBL2	11	1,24	1,000	0,680	0,906	12,000	0°	-3,519°	
A20T-SVUBL3	16	1,705	1,250	1,000	1,181	12,000	0°	-8,696°	VB .. 1604 .. VB .. 33 ..
A24T-SVUBL3	16	2,126	1,500	1,125	1,374	12,000	0°	-5,997°	

Dimensional drawing shows right-hand version. | Measured with master insert: VB .. 110304 / VB .. 160408 | Refer to the Walter online catalogue for more product information: [www.walter-tools.com](http://www.walter-tools.com) | Bodies and assembly parts are included in the scope of delivery

## Assembly parts

	Type $D_{min}$ (inch)	VB .. 1103 .. 0,85–1,24	VB .. 1604 .. 1,705–2,126
	Clamping screw for indexable insert Tightening torque	FS2172 (T7IP) 0,664 lbs	FS2060 (T15IP) 2,213 lbs
	Shim		AP316-VB1608
	Screw for shim		FS2068 (SW 3,5)
	Torx key	FS1490 (T7IP)	FS1465 (T15IP)

## Boring bar – Screw clamping

A...-SWLC

Walter Turn



– A = Steel version with internal cooling

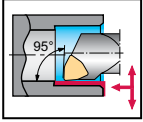

### Tool

Designation		$D_{min}$ mm	$d_1$ mm	$f$ mm	$h$ mm	$l_1$ mm	$\gamma$	$\lambda_s$	Type
A10K-SWLCR04		4	12	10	7	9	0°	-10°	WC .. 0402 ..
A12M-SWLCR04		4	16	12	9	11	0°	-7°	
A16R-SWLCR04		4	20	16	11	15	0°	-5°	
A20S-SWLCR06		6	25	20	13	18	0°	-6°	WC .. 06T3 ..
A25T-SWLCR06		6	32	25	17	23	0°	-3,5°	
A25T-SWLCR08		8	32	25	17	23	0°	-4°	WC .. 0804 ..
A10K-SWLCLO4		4	12	10	7	9	0°	-10°	WC .. 0402 ..
A12M-SWLCLO4		4	16	12	9	11	0°	-7°	
A16R-SWLCLO4		4	20	16	11	15	0°	-5°	
A20S-SWLCLO6		6	25	20	13	18	0°	-6°	WC .. 06T3 ..
A25T-SWLCLO6		6	32	25	17	23	0°	-3,5°	
A25T-SWLCLO8		8	32	25	17	23	0°	-4°	WC .. 0804 ..

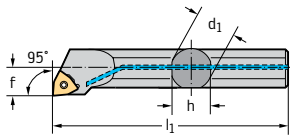

Parallel shank with clamping surface

Dimensional drawing shows right-hand version. | Measured with master insert: WC .. 040204 / WC .. 06T308 / WC .. 080408 | Refer to the Walter online catalogue for more product information: [www.walter-tools.com](http://www.walter-tools.com) | Bodies and assembly parts are included in the scope of delivery

### Assembly parts

Type	Type	WC .. 0402 .. 12–20	WC .. 06T3 .. 25–32	WC .. 0804 .. 32
	Clamping screw for indexable insert Tightening torque	FS2067 (T7IP) 0,9 Nm	FS2062 (T15IP) 3 Nm	FS2064 (T15IP) 3 Nm
	Torx key	FS1490 (T7IP)	FS1465 (T15IP)	FS1496 (T15IP)

## Boring bar – Screw clamping

A...-SWLC inch

Walter Turn

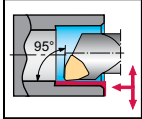

## Tool

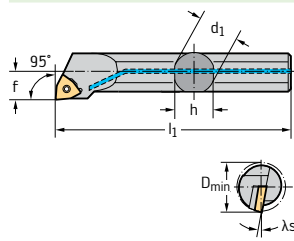

Parallel shank with clamping surface

Designation		$D_{min}$ inch	$d_1$ inch	$f$ inch	$h$ inch	$l_1$ inch	$\gamma$	$\lambda_s$	Type
A06M-SWLCR2	4	0,500	0,375	0,250	0,336	6,000	0°	-11°	WC .. 0402 .. WC .. 2(1.5) ..
A08M-SWLCR2	4	0,625	0,500	0,312	0,460	6,000	0°	-8°	
A10R-SWLCR3	6	0,750	0,625	0,375	0,562	8,000	0°	-10°	WC .. 06T3 .. WC .. 3(2.5) ..
A12S-SWLCR3	6	1,000	0,750	0,500	0,709	10,000	0°	-6,5°	
A16T-SWLCR3	6	1,280	1,000	0,640	0,906	12,000	0°	-4°	
A06M-SWLCL2	4	0,500	0,375	0,250	0,336	6,000	0°	-11°	WC .. 0402 .. WC .. 2(1.5) ..
A08M-SWLCL2	4	0,625	0,500	0,312	0,460	6,000	0°	-8°	
A10R-SWLCL3	6	0,750	0,625	0,375	0,562	8,000	0°	-10°	WC .. 06T3 .. WC .. 3(2.5) ..
A12S-SWLCL3	6	1,000	0,750	0,500	0,709	10,000	0°	-6,5°	
A16T-SWLCL3	6	1,280	1,000	0,640	0,906	12,000	0°	-4°	

Dimensional drawing shows right-hand version. | Measured with master insert: WC .. 040204 / WC .. 06T308 | Refer to the Walter online catalogue for more product information: [www.walter-tools.com](http://www.walter-tools.com) | Bodies and assembly parts are included in the scope of delivery

## Assembly parts

	Type $D_{min}$ [inch]	WC .. 0402 .. 0,5–0,625	WC .. 06T3 .. 0,75–1,28
	Clamping screw for indexable insert Tightening torque	FS2067 (T7IP) 0,664 lbs	FS2062 (T15IP) 2,213 lbs
	Torx key	FS1490 (T7IP)	FS1465 (T15IP)

# Boring bar – Screw clamping

E...-SWLC inch

**Walter Turn**



– E = Solid carbide version with internal cooling

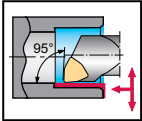

Tool	Designation		$D_{min}$ inch	$d_1$ inch	$f$ inch	$h$ inch	$l_1$ inch	$\gamma$	$\lambda_s$	Type
	E06M-SWLCR2	4	0,500	0,375	0,250	0,359	6,000	0°	-11°	WC .. 0402 .. WC .. 2(1.5) ..
	E08R-SWLCR2	4	0,625	0,500	0,312	0,460	8,000	0°	-8°	
	E06M-SWLCL2	4	0,500	0,375	0,250	0,359	6,000	0°	-11°	WC .. 0402 .. WC .. 2(1.5) ..
	E08R-SWLCL2	4	0,625	0,500	0,312	0,460	6,000	0°	-8°	

Parallel shank with clamping surface

Dimensional drawing shows right-hand version. | Measured with master insert: WC .. 040204 | Refer to the Walter online catalogue for more product information: [www.walter-tools.com](http://www.walter-tools.com) | Bodies and assembly parts are included in the scope of delivery

Assembly parts	Type $D_{min}$ [inch]	WC .. 0402 .. 0,5–0,625
	Clamping screw for indexable insert Tightening torque	FS2067 (T7IP) 0,664 lbs
	Torx key	FS1490 (T7IP)

## Boring bar – Copy turning system

**W1211** 
**Walter Turn**

– Double internal coolant supply

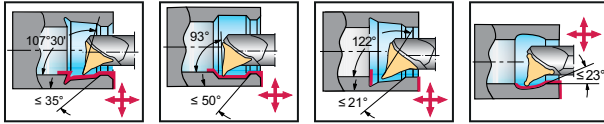

### Tool

	Designation		$d_1$ mm	$D_{min}$ mm	$f$ mm	$h$ mm	$l_1$ mm	$l_4$ mm	$X_1$ mm	$\gamma$	$\lambda_s$	Type
	W1211-12MR-WL17		17	12	10	11,5	150	23	4,5	-3,2°	-7,5°	WL17..
	W1211-16RR-WL17		17	16	11	15	200	23	4	-3,2°	-7,5°	
	W1211-20SR-WL17		17	20	14	18,5	250	28	5,5	-2,7°	-7,6°	
	W1211-12ML-WL17		17	12	10	11,5	150	23	4,5	-3,2°	-7,5°	WL17..
	W1211-16RL-WL17		17	16	11	15	200	23	4	-3,2°	-7,5°	
	W1211-20SL-WL17		17	20	14	18,5	250	28	5,5	-2,7°	-7,6°	

Parallel shank with clamping surface

 Dimensional drawing shows right-hand version. | Measured with master insert: WL17-VC050804N-FM4 | The maximum recommended coolant pressure is 80 bar (1160 psi) | Refer to the Walter online catalogue for more product information: [www.walter-tools.com](http://www.walter-tools.com) | Bodies and assembly parts are included in the scope of delivery

### Assembly parts

	Type $d_1$ [mm]	WL17.. 12–20
	Clamping screw for indexable insert Tightening torque	FS1457 (T9IP) 2 Nm
	Torx key	FS1466 (T9IP)



# Boring bar – Copy turning system

W1211

Walter Turn



- Double internal coolant supply
- Additional coolant hole for blind hole machining

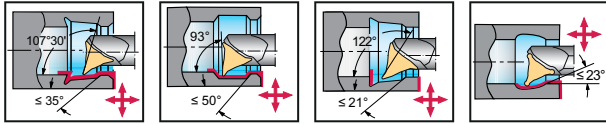

Tool	Designation		d <sub>1</sub> mm	D <sub>min</sub> mm	f mm	h mm	l <sub>1</sub> mm	l <sub>4</sub> mm	X <sub>1</sub> mm	γ	λ <sub>s</sub>	Type	
	W1211-25TR-WL25		25	25	32	17	23	300	35	7	-1,3°	-7,5°	WL25..
	W1211-32TR-WL25		25	32	40	23	30	300	45	9,5	-1,3°	-7,5°	
	W1211-40TR-WL25		25	40	50	27,5	37	300	54	10	-1,3°	-7,5°	
	W1211-25TL-WL25		25	25	32	17	23	300	35	7	-1,3°	-7,5°	WL25..
	W1211-32TL-WL25		25	32	40	23	30	300	45	9,5	-1,3°	-7,5°	
	W1211-40TL-WL25		25	40	50	27,5	37	300	54	10	-1,3°	-7,5°	

Parallel shank with clamping surface

Dimensional drawing shows right-hand version. | Measured with master insert: WL25-VC0708N-MM4 | The maximum recommended coolant pressure is 80 bar (1160 psi) | Refer to the Walter online catalogue for more product information: [www.walter-tools.com](http://www.walter-tools.com) | Bodies and assembly parts are included in the scope of delivery

Assembly parts		Type	WL25.. 25-40
	Clamping screw for indexable insert Tightening torque		FS1495 (T20IP) 5 Nm
	Threaded plug		FS2082 (T6IP)
	Allen key		FS1464 (T20IP)

Accessories	Type	WL25..			
		d <sub>1</sub> [mm]	25	32	40
	Coolant sealing adapter		CN3000-25-8.5	CN3000-32-8.5	CN3000-40-11.5

●● Primary application   ● Other application  
 Best tool for → Good = 😊 → Average = 😐 → Poor = 😞 machining conditions

## Boring bar – Copy turning system

**W1211** inch
**Walter Turn**

- Double internal coolant supply
- Additional coolant hole for blind hole machining

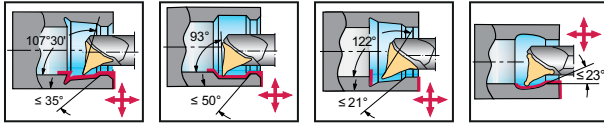

### Tool

Designation		d <sub>1</sub> inch	D <sub>min</sub> inch	f inch	h inch	l <sub>1</sub> inch	l <sub>4</sub> inch	X <sub>1</sub> inch	γ	λ <sub>s</sub>	Type	
											WL25..	
W1211.16TR-WL25		25	1,000	1,260	0,669	0,906	12,049	1,378	0,217	-1,3°	-7,5°	WL25..
W1211.20TR-WL25		25	1,250	1,575	0,906	1,181	12,049	1,772	0,315	-1,3°	-7,5°	WL25..
W1211.16TL-WL25		25	1,000	1,260	0,669	0,906	12,049	1,378	0,217	-1,3°	-7,5°	WL25..
W1211.20TL-WL25		25	1,250	1,575	0,906	1,181	12,049	1,772	0,315	-1,3°	-7,5°	WL25..

Parallel shank with clamping surface

Dimensional drawing shows right-hand version. | Measured with master insert: WL25-VC0708N-MM4 | The maximum recommended coolant pressure is 80 bar (1160 psi) | Refer to the Walter online catalogue for more product information: [www.walter-tools.com](http://www.walter-tools.com) | Bodies and assembly parts are included in the scope of delivery

### Assembly parts

	Type	WL25..
	d <sub>1</sub> [inch]	1-1,25
	Clamping screw for indexable insert Tightening torque	FS1495 (T20IP) 3,688 lbs
	Threaded plug	FS2082 (T6IP)
	Allen key	FS1464 (T20IP)

### Accessories

Type	WL25..	WL25..
d <sub>1</sub> [inch]	1	1,25
	Coolant sealing adapter	CN3000-25-8.5
		CN3000-32-8.5

**WALTER  
SELECT**

●● Primary application ● Other application  
 Best tool for → Good = 😊 → Average = 😐 → Poor = 😞 machining conditions

# Boring bar – Copy turning system

W1210

Walter Turn



- Double internal coolant supply
- With WL form-fit system

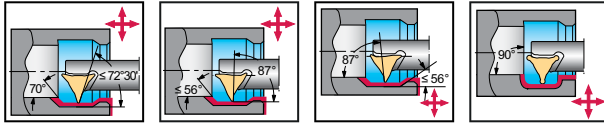

Tool	Designation		D <sub>min</sub> mm	d <sub>1</sub> mm	f mm	h mm	l <sub>1</sub> mm	l <sub>4</sub> mm	l <sub>20</sub> mm	X <sub>1</sub> mm	γ	λ <sub>s</sub>	Type	
	W1210-12MR-WL17		17	19	12	12	11	157	21	157	6,5	-2,4°	-7,6°	WL17..
	W1210-16RR-WL17		17	22	16	13	15	207	23	207	6	-2,4°	-7,6°	WL17..
	W1210-20SR-WL17		17	26	20	15	18	257	26	257	6,5	-2,4°	-7,6°	WL17..
	W1210-12ML-WL17		17	19	12	12	11	157	21	157	6,5	-2,4°	-7,6°	WL17..
	W1210-16RL-WL17		17	22	16	13	15	207	23	207	6	-2,4°	-7,6°	WL17..
	W1210-20SL-WL17		17	26	20	15	18	257	26	257	6,5	-2,4°	-7,6°	WL17..

Parallel shank with clamping surface

Dimensional drawing shows right-hand version. | Measured with master insert: WL17-VC050804N-FM4 | The maximum recommended coolant pressure is 80 bar (1160 psi) | Refer to the Walter online catalogue for more product information: [www.walter-tools.com](http://www.walter-tools.com) | Bodies and assembly parts are included in the scope of delivery

Assembly parts		Type	WL17..
	Clamping screw for indexable insert Tightening torque		FS1457 (T9IP) 2 Nm
	Torx key		FS1466 (T9IP)

**WALTER SELECT**

Best tool for → Good = 😊 → Average = 😐 → Poor = 😞 machining conditions

●● Primary application ● Other application

## Boring bar – Copy turning system

**W1210** 
**Walter Turn**

- Double internal coolant supply
- Additional coolant hole for blind hole machining

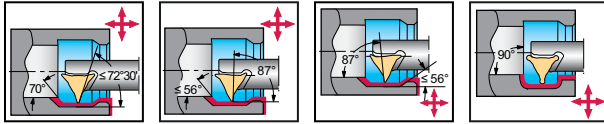

### Tool

Designation		$D_{min}$ mm	$d_1$ mm	$f$ mm	$h$ mm	$l_1$ mm	$l_4$ mm	$l_{20}$ mm	$X_1$ mm	$\gamma$	$\lambda_s$	Type	
												Type	
W1210-25TR-WL25		25	34	25	20	23	300	30	310	10	-1,5°	-4,8°	WL25..
W1210-32TR-WL25		25	44	32	27	30	300	31	310	13,5	-1,5°	-4,8°	WL25..
W1210-40TR-WL25		25	52	40	31	37	300	35	310	13,5	-1,5°	-4,8°	WL25..
W1210-25TL-WL25		25	34	25	20	23	300	30	310	10	-1,5°	-4,8°	WL25..
W1210-32TL-WL25		25	44	32	27	30	300	31	310	13,5	-1,5°	-4,8°	WL25..
W1210-40TL-WL25		25	52	40	31	37	300	35	310	13,5	-1,5°	-4,8°	WL25..

Parallel shank with clamping surface

 Dimensional drawing shows right-hand version. | Measured with master insert: WL25-VC0708N-MM4 | The maximum recommended coolant pressure is 80 bar (1160 psi) | Refer to the Walter online catalogue for more product information: [www.walter-tools.com](http://www.walter-tools.com) | Bodies and assembly parts are included in the scope of delivery

### Assembly parts

	Type	WL25..
	Clamping screw for indexable insert Tightening torque	FS1495 (T20IP) 5 Nm
	Threaded plug	FS2082 (T6IP)
	Allen key	FS1464 (T20IP)

### Accessories

	Type	WL25..
	Coolant sealing adapter	CN3000-25-8.5

## Boring bar adaptor

### A2140-W mm

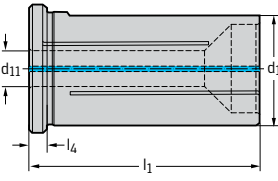

- With Weldon shank in accordance with DIN 9766
- Self-centring for parallel round shank

Tool	Designation	$d_1$	$d_{11}$ mm	$l_1$ mm	$l_4$ mm	 kg
 <p>Cylindrical shank with flat</p>	A2140-W16-R06-048	16	6	48	5	0,06
	A2140-W16-R08-048	16	8	48	5	0,06
	A2140-W16-R10-048	16	10	48	5	0,05
	A2140-W16-R12-048	16	12	48	5	0,04
	A2140-W20-R06-055	20	6	55	5	0,11
	A2140-W20-R08-055	20	8	55	5	0,11
	A2140-W20-R10-055	20	10	55	5	0,1
	A2140-W20-R12-055	20	12	55	5	0,09
	A2140-W20-R16-055	20	16	55	5	0,06
	A2140-W25-R06-061	25	6	61	5	0,2
	A2140-W25-R08-061	25	8	61	5	0,19
	A2140-W25-R10-061	25	10	61	5	0,19
	A2140-W25-R12-061	25	12	61	5	0,17
	A2140-W25-R16-061	25	16	61	5	0,14
	A2140-W32-R06-065	32	6	65	5	0,33
	A2140-W32-R08-065	32	8	65	5	0,33
	A2140-W32-R10-065	32	10	65	5	0,33
	A2140-W32-R12-065	32	12	65	5	0,31
	A2140-W32-R16-065	32	16	65	5	0,28
	A2140-W32-R20-065	32	20	65	5	0,25
	A2140-W40-R06-075	40	6	75	5	0,6
	A2140-W40-R08-075	40	8	75	5	0,61
	A2140-W40-R10-075	40	10	75	5	0,62
	A2140-W40-R12-075	40	12	75	5	0,62
	A2140-W40-R16-075	40	16	75	5	0,56
	A2140-W40-R20-075	40	20	75	5	0,55
	A2140-W40-R25-075	40	25	75	5	0,43

Note: Groove for self-centring is present on all Walter Turn boring bars with cylindrical shank (-R) dia. 6–25 mm. | The maximum recommended coolant pressure is 80 bar (1160 psi)

## Boring bar – Rigid clamping

C...-DCLN 

## Walter Turn

– Walter Capto™

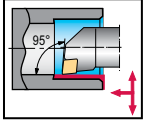

## Tool

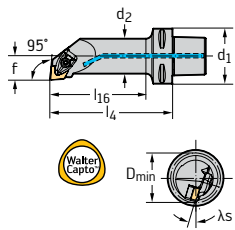

Walter Capto™ in acc. with ISO 26623

Designation		d <sub>1</sub>	D <sub>min</sub> mm	d <sub>2</sub> mm	f mm	l <sub>4</sub> mm	l <sub>16</sub> mm	γ	λ <sub>s</sub>	Type
C4-DCLNR-17090-12		12	C4	32	25	17	90	-6°	-12°	CN .. 1204 ..
C5-DCLNR-17090-12		12	C5	32	25	17	90	-6°	-12°	
C6-DCLNR-17100-12		12	C6	32	25	17	100	-6°	-12°	
C6-DCLNR-27140-16		16	C6	50	40	27	140	-6°	-16°	CN .. 1606 ..
C4-DCLNL-17090-12		12	C4	32	25	17	90	-6°	-12°	CN .. 1204 ..
C5-DCLNL-17090-12		12	C5	32	25	17	90	-6°	-12°	
C6-DCLNL-17100-12		12	C6	32	25	17	100	-6°	-12°	
C6-DCLNL-27140-16		16	C6	50	40	27	140	-6°	-16°	CN .. 1606 ..

Dimensional drawing shows right-hand version. | Measured with master insert: CN .. 120408 / CN .. 160612 | Refer to the Walter online catalogue for more product information: [www.walter-tools.com](http://www.walter-tools.com) | Bodies and assembly parts are included in the scope of delivery

## Assembly parts

Type	D <sub>min</sub> [mm]	CN .. 1204 .. 32	CN .. 1606 .. 50
	Shim	AP354-CN12	AP302-CN16
	Screw for shim Tightening torque	FS1461 (T15IP) 2,5 Nm	FS1463 (T20IP) 5 Nm
	Clamp	PK241	PK242
	Screw for clamp Tightening torque	FS1473 (T15IP) 3,9 Nm	FS1474 (T20IP) 6,4 Nm
	Pressure spring	FS1470	FS1471
	Pin	RS117	RS117
	Torx key	FS1465 (T15IP)	
	Allen key		FS1464 (T20IP)

## Accessories

Type	CN .. 1204 ..	CN .. 1606 ..
(standard assembly parts) Clamp set	PK241-SET	
Insert with hole Carbide clamp set	PK245-SET	
(standard assembly parts) Clamp set		PK242-SET
Insert with hole Carbide clamp set		PK246-SET
Insert with hole Carbide clamp set	PK254-SET	

# Boring bar – Lever clamping

C...-PCLN

Walter Turn





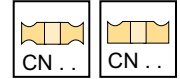
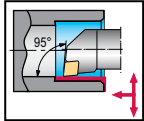



– Walter Capto™



Tool	Designation		$d_1$	$D_{min}$ mm	$d_2$ mm	$f$ mm	$l_4$ mm	$l_{16}$ mm	$\gamma$	$\lambda_s$	Type
<p>Walter Capto™ in acc. with ISO 26623</p>	C3-PCLNR-17090-12	12	C3	32	25	17	90	75	-6°	-11°	CN .. 1204 ..
	C4-PCLNR-17090-12	12	C4	32	25	17	90	69	-6°	-11°	
	C4-PCLNR-22110-12	12	C4	40	32	22	110	89	-6°	-11°	
	C4-PCLNR-27080-12	12	C4	50	40	27	80	60	-6°	-10°	
	C4-PCLNR-27120-12	12	C4	50	40	27	120	100	-6°	-11°	
	C5-PCLNR-17090-12	12	C5	32	25	17	90	67	-6°	-11°	
	C5-PCLNR-22110-12	12	C5	40	32	22	110	88	-6°	-11°	
	C5-PCLNR-27140-12	12	C5	50	40	27	140	119	-6°	-10°	
	C5-PCLNR-35100-12	12	C5	63	50	35	100	81	-6°	-7°	
	C6-PCLNR-17100-12	12	C6	32	25	17	100	74	-6°	-11°	
C6-PCLNR-22110-12	12	C6	40	32	22	110	84	-6°	-11°		
C5-PCLNR-35150-16	16	C5	63	50	35	150	131	-6°	-11°	CN .. 1606 ..	
C6-PCLNR-27140-16	16	C6	50	40	27	140	115	-6°	-11°		
C6-PCLNR-35175-16	16	C6	63	50	35	175	152	-6°	-11°		
C3-PCLNL-17090-12	12	C3	32	25	17	90	75	-6°	-11°	CN .. 1204 ..	
C4-PCLNL-17090-12	12	C4	32	25	17	90	69	-6°	-11°		
C4-PCLNL-22110-12	12	C4	40	32	22	110	89	-6°	-11°		
C4-PCLNL-27080-12	12	C4	50	40	27	80	60	-6°	-10°		
C4-PCLNL-27120-12	12	C4	50	40	27	120	100	-6°	-11°		
C5-PCLNL-17090-12	12	C5	32	25	17	90	67	-6°	-11°		
C5-PCLNL-22110-12	12	C5	40	32	22	110	88	-6°	-11°		
C5-PCLNL-27140-12	12	C5	50	40	27	140	119	-6°	-10°		
C5-PCLNL-35100-12	12	C5	63	50	35	100	81	-6°	-7°		
C6-PCLNL-17100-12	12	C6	32	25	17	100	74	-6°	-11°		
C6-PCLNL-22110-12	12	C6	40	32	22	110	84	-6°	-11°		
C5-PCLNL-35150-16	16	C5	63	50	35	150	131	-6°	-11°	CN .. 1606 ..	
C6-PCLNL-27140-16	16	C6	50	40	27	140	115	-6°	-11°		
C6-PCLNL-35175-16	16	C6	63	50	35	175	152	-6°	-11°		

Dimensional drawing shows right-hand version. | Measured with master insert: CN .. 120408 / CN .. 160612 | Refer to the Walter online catalogue for more product information: [www.walter-tools.com](http://www.walter-tools.com) | Bodies and assembly parts are included in the scope of delivery

Assembly parts				
	Type D <sub>min</sub> [mm]	CN .. 1204 .. 32	CN .. 1204 .. 40-63	CN .. 1606 .. 50-63
	Shim		AP134-CN1216	AP135-CN1624
	Lever	KN109	KN102	KN104
	Clamping screw Tightening torque	FS332 (SW 2,5) 2,5 Nm	FS352 (SW 3) 5 Nm	FS354 (SW 3) 5 Nm
	Shim pin		RS102	RS103
	Tapered assembly pin		MD101	MD102
	Allen key	ISO2936-2.5 (SW 2,5)	ISO2936-3 (SW 3)	ISO2936-3 (SW 3)
Accessories				
	Type	CN .. 1204 ..	CN .. 1606 ..	
	Shim	AP134-CN1208	AP135-CN1616	



# Boring bar – Rigid clamping

C...-DDUN

## Walter Turn

– Walter Capto™

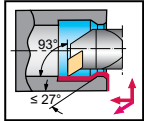

### Tool

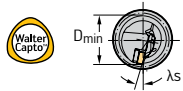
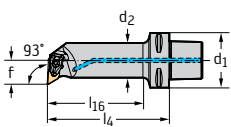

Walter Capto™ in acc. with ISO 26623

Designation		$d_1$	$D_{min}$ mm	$d_2$ mm	$f$ mm	$l_4$ mm	$l_{16}$ mm	$\gamma$	$\lambda_s$	Type
C4-DDUNR-17090-11		11	C4	32	25	17	90	-6°	-12°	DN .. 1104 ..
C5-DDUNR-17090-11		11	C5	32	25	17	90	-6°	-12°	
C4-DDUNR-27080-15		15	C4	50	40	27	80	-6°	-11°	DN .. 1506 ..
C5-DDUNR-27140-15		15	C5	50	40	27	140	-6°	-11°	
C6-DDUNR-27140-15		15	C6	50	40	27	140	-6°	-11°	
C4-DDUNL-17090-11		11	C4	32	25	17	90	-6°	-12°	DN .. 1104 ..
C5-DDUNL-17090-11		11	C5	32	25	17	90	-6°	-12°	
C4-DDUNL-27080-15		15	C4	50	40	27	80	-6°	-11°	DN .. 1506 ..
C5-DDUNL-27140-15		15	C5	50	40	27	140	-6°	-11°	
C6-DDUNL-27140-15		15	C6	50	40	27	140	-6°	-11°	

Dimensional drawing shows right-hand version. | Measured with master insert: DN .. 110408 / DN .. 150608 | Refer to the Walter online catalogue for more product information: [www.walter-tools.com](http://www.walter-tools.com) | Bodies and assembly parts are included in the scope of delivery

### Assembly parts

Type $D_{min}$ [mm]	DN .. 1104 .. 32	DN .. 1506 .. 50
Shim	AP305-DN11	AP304-DN15
Screw for shim Tightening torque	FS1462 (T9IP) 1,5 Nm	FS1461 (T15IP) 2,5 Nm
Clamp	PK240	PK241
Screw for clamp Tightening torque	FS1472 (T9IP) 1,7 Nm	FS1473 (T15IP) 3,9 Nm
Pressure spring	FS1469	FS1470
Pin	RS116	RS117
Torx key	FS1466 (T9IP)	FS1465 (T15IP)

### Accessories

Type	DN .. 1104 ..	DN .. 1506 ..
(standard assembly parts) Clamp set	PK240-SET	PK241-SET
Insert without hole Carbide clamp set		PK245-SET
Insert without hole Carbide clamp set		PK254-SET
Shim for DN .. 1504 ..		AP304-DN1504

## Boring bar – Lever clamping

C...-PDUN

### Walter Turn

– Walter Capto™

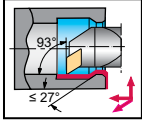

#### Tool

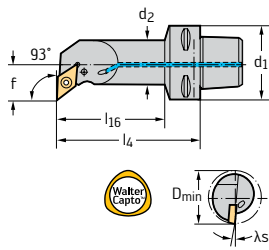

Walter Capto™ in acc. with ISO 26623



Designation		d <sub>1</sub>	D <sub>min</sub> mm	d <sub>2</sub> mm	f mm	l <sub>4</sub> mm	l <sub>16</sub> mm	γ	λ <sub>s</sub>	Type
C3-PDUNR-17090-11	11	C3	32	25	17	90	75	-6°	-11°	DN .. 1104 ..
C4-PDUNR-17090-11	11	C4	32	25	17	90	69	-6°	-11°	
C4-PDUNR-22110-11	11	C4	40	32	22	110	89	-6°	-10°	
C5-PDUNR-17090-11	11	C5	32	25	17	90	67	-6°	-11°	
C5-PDUNR-22110-11	11	C5	40	32	22	110	88	-6°	-10°	
C6-PDUNR-17100-11	11	C6	32	25	17	100	74	-6°	-11°	
C4-PDUNR-27080-15	15	C4	50	40	27	80	60	-6°	-11°	DN .. 1506 ..
C4-PDUNR-27120-15	15	C4	50	40	27	120	100	-6°	-11°	
C5-PDUNR-27140-15	15	C5	50	40	27	140	119	-6°	-11°	
C5-PDUNR-35100-15	15	C5	63	50	35	100	81	-6°	-10°	
C5-PDUNR-35150-15	15	C5	63	50	35	150	131	-6°	-10°	
C6-PDUNR-27140-15	15	C6	50	40	27	140	115	-6°	-11°	
C6-PDUNR-35175-15	15	C6	63	50	35	175	152	-6°	-10°	
C3-PDUNL-17090-11	11	C3	32	25	17	90	75	-6°	-11°	DN .. 1104 ..
C4-PDUNL-17090-11	11	C4	32	25	17	90	69	-6°	-11°	
C4-PDUNL-22110-11	11	C4	40	32	22	110	89	-6°	-10°	
C5-PDUNL-17090-11	11	C5	32	25	17	90	67	-6°	-11°	
C5-PDUNL-22110-11	11	C5	40	32	22	110	88	-6°	-10°	
C6-PDUNL-17100-11	11	C6	32	25	17	100	74	-6°	-11°	
C4-PDUNL-27080-15	15	C4	50	40	27	80	60	-6°	-11°	DN .. 1506 ..
C4-PDUNL-27120-15	15	C4	50	40	27	120	100	-6°	-11°	
C5-PDUNL-27140-15	15	C5	50	40	27	140	119	-6°	-11°	
C5-PDUNL-35100-15	15	C5	63	50	35	100	81	-6°	-10°	
C5-PDUNL-35150-15	15	C5	63	50	35	150	131	-6°	-10°	
C6-PDUNL-27140-15	15	C6	50	40	27	140	115	-6°	-11°	
C6-PDUNL-35175-15	15	C6	63	50	35	175	152	-6°	-10°	

Dimensional drawing shows right-hand version. | Measured with master insert: DN .. 110408 / DN .. 150608 | Refer to the Walter online catalogue for more product information: [www.walter-tools.com](http://www.walter-tools.com) | Bodies and assembly parts are included in the scope of delivery

#### Assembly parts

Type	D <sub>min</sub> [mm]	DN .. 1104 .. 32	DN .. 1104 .. 40	DN .. 1506 .. 50-63
	Shim		AP171-DN1112	AP145-DN1516
	Lever	KN120	KN119	KN103
	Clamping screw Tightening torque	FS905 (SW 2) 2 Nm	FS351 (SW 2,5) 2 Nm	FS355 (SW 3) 5 Nm
	Shim pin		RS101	RS102
	Tapered assembly pin		MD101	MD101
	Allen key	ISO2936-2 (SW 2)	ISO2936-2,5 (SW 2,5)	ISO2936-3 (SW 3)

## Accessories

	Type	DN .. 1104 ..	DN .. 1506 ..
	Shim	AP171-DN1108	AP145-DN1508
	Shim for DN .. 1504 ..		AP357-DN1508
	Shim for DN .. 1504 ..		AP357-DN1516

## Boring bar – Lever clamping

C...-PSKN 

## Walter Turn

– Walter Capto™

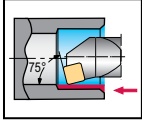

## Tool

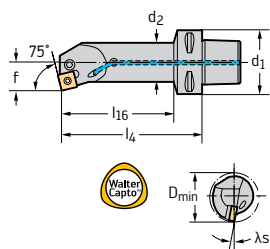

Designation		d <sub>1</sub>	D <sub>min</sub> mm	d <sub>2</sub> mm	f mm	l <sub>4</sub> mm	l <sub>16</sub> mm	γ	λ <sub>s</sub>	Type	
C5-PSKNR-27140-12		12	C5	50	40	27	140	119	-6°	-10°	SN .. 1204 ..
C6-PSKNR-35175-15		15	C6	63	50	35	175	152	-6°	-9°	SN .. 1506 ..
C5-PSKNL-27140-12		12	C5	50	40	27	140	119	-6°	-10°	SN .. 1204 ..
C6-PSKNL-35175-15		15	C6	63	50	35	175	152	-6°	-9°	SN .. 1506 ..

Walter Capto™ in acc. with ISO 26623

Dimensional drawing shows right-hand version. | Measured with master insert: SN .. 120408 / SN .. 150608 | Refer to the Walter online catalogue for more product information: [www.walter-tools.com](http://www.walter-tools.com) | Bodies and assembly parts are included in the scope of delivery

## Assembly parts

Type	D <sub>min</sub> [mm]	SN .. 1204 .. 50	SN .. 1506 .. 63
	Shim	AP141-SN1216	AP142-SN1524
	Lever	KN102	KN104
	Clamping screw Tightening torque	FS352 (SW 3) 5 Nm	FS354 (SW 3) 5 Nm
	Shim pin	RS102	RS103
	Tapered assembly pin	MD101	MD102
	Allen key	ISO2936-3 (SW 3)	ISO2936-3 (SW 3)

## Accessories

Type	SN .. 1204 ..	SN .. 1506 ..	
	Shim	AP141-SN1208	AP142-SN1516

## Boring bar – Lever clamping

C...-PTFN 

## Walter Turn

– Walter Capto™

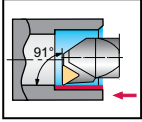

## Tool

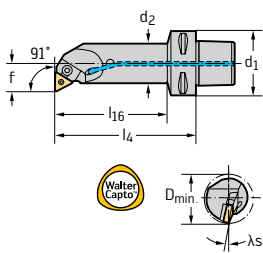

Walter Capto™ in acc. with ISO 26623

Designation		d <sub>1</sub>	D <sub>min</sub> mm	d <sub>2</sub> mm	f mm	l <sub>4</sub> mm	l <sub>16</sub> mm	γ	λ <sub>s</sub>	Type
C4-PTFNR-17090-16W	16	C4	32	25	17	90	69	-6°	-13°	TN .. 1604 ..
C4-PTFNR-22110-16W	16	C4	40	32	22	110	89	-6°	-12°	
C5-PTFNR-17090-16W	16	C5	32	25	17	90	67	-6°	-13°	
C5-PTFNR-22110-16W	16	C5	40	32	22	110	88	-6°	-12°	
C6-PTFNR-22110-16W	16	C6	40	32	22	110	84	-6°	-12°	
C5-PTFNR-35150-22W	22	C5	63	50	35	150	131	-6°	-11°	TN .. 2204 ..
C6-PTFNR-27140-22W	22	C6	50	40	27	140	115	-6°	-11°	
C6-PTFNR-35175-22W	22	C6	63	50	35	175	152	-6°	-10°	
C4-PTFNL-17090-16W	16	C4	32	25	17	90	69	-6°	-13°	TN .. 1604 ..
C4-PTFNL-22110-16W	16	C4	40	32	22	110	89	-6°	-12°	
C5-PTFNL-17090-16W	16	C5	32	25	17	90	67	-6°	-13°	
C5-PTFNL-22110-16W	16	C5	40	32	22	110	88	-6°	-12°	
C6-PTFNL-22110-16W	16	C6	40	32	22	110	84	-6°	-12°	
C5-PTFNL-35150-22W	22	C5	63	50	35	150	131	-6°	-10°	TN .. 2204 ..
C6-PTFNL-27140-22W	22	C6	50	40	27	140	115	-6°	-11°	
C6-PTFNL-35175-22W	22	C6	63	50	35	175	152	-6°	-10°	

Dimensional drawing shows right-hand version. | Measured with master insert: TN .. 160408 / TN .. 220408 | Refer to the Walter online catalogue for more product information: [www.walter-tools.com](http://www.walter-tools.com) | Bodies and assembly parts are included in the scope of delivery

## Assembly parts

Type	D <sub>min</sub> [mm]	TN .. 1604 .. 32	TN .. 1604 .. 40	TN .. 2204 .. 50-63
	Shim		AP147	AP148
	Wedge set	FK307	FK308	FK309
	Pin	RS113	RS114	RS115
	Screw	FS1156 (T9IP)	FS1156 (T9IP)	FS1158 (T15IP)
	Allen key	ISO2936-3 (SW 3)	ISO2936-3 (SW 3)	ISO2936-4 (SW 4)

## Boring bar – Rigid clamping

C...-DWLN 

## Walter Turn

– Walter Capto™

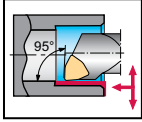

## Tool

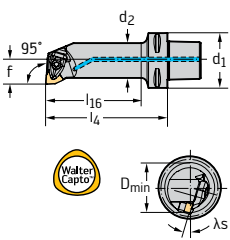

Designation		d <sub>1</sub>	D <sub>min</sub> mm	d <sub>2</sub> mm	f mm	l <sub>4</sub> mm	l <sub>16</sub> mm	γ	λ <sub>s</sub>	Type	
C4-DWLN-13075-06		6	C4	27	20	13	75	52	-6°	-17°	WN .. 0604 ..
C4-DWLN-17090-08		8	C4	33	25	17	90	68	-6°	-12°	WN .. 0804 ..
C5-DWLN-17090-08		8	C5	33	25	17	90	66	-6°	-12°	WN .. 0804 ..
C6-DWLN-27140-10		10	C6	50	40	27	140	114	-6°	-16°	WN .. 1006 ..
C4-DWLN-13075-06		6	C4	27	20	13	75	52	-6°	-17°	WN .. 0604 ..
C4-DWLN-17090-08		8	C4	33	25	17	90	68	-6°	-12°	WN .. 0804 ..
C5-DWLN-17090-08		8	C5	33	25	17	90	66	-6°	-12°	WN .. 0804 ..
C6-DWLN-27140-10		10	C6	50	40	27	140	114	-6°	-16°	WN .. 1006 ..

Walter Capto™ in acc. with ISO 26623

Dimensional drawing shows right-hand version. | Measured with master insert: WN .. 060408 / WN .. 080408 / WN .. 100612 | Refer to the Walter online catalogue for more product information: [www.walter-tools.com](http://www.walter-tools.com) | Bodies and assembly parts are included in the scope of delivery

## Assembly parts

Type	D <sub>min</sub> [mm]	WN .. 0604 .. 27	WN .. 0804 .. 33	WN .. 1006 .. 50
	Shim	AP306-WN06	AP331-WN08	AP311-WN10
	Screw for shim Tightening torque	FS1462 (T9IP) 1,5 Nm	FS1461 (T15IP) 2,5 Nm	FS1463 (T20IP) 5 Nm
	Clamp	PK240	PK241	PK242
	Screw for clamp Tightening torque	FS1472 (T9IP) 1,7 Nm	FS1473 (T15IP) 3,9 Nm	FS1474 (T20IP) 6,4 Nm
	Pressure spring	FS1469	FS1470	FS1471
	Pin	RS116	RS117	RS117
	Torx key	FS1466 (T9IP)	FS1465 (T15IP)	
	Allen key			FS1464 (T20IP)

## Accessories

Type	WN .. 0604 ..	WN .. 0804 ..	WN .. 1006 ..
(standard assembly parts) Clamp set	PK240-SET	PK241-SET	PK242-SET
Insert with hole Carbide clamp set		PK245-SET	PK246-SET
Insert with hole Carbide clamp set		PK254-SET	

## Boring bar – Lever clamping

C...-PWLN 

## Walter Turn

– Walter Capto™

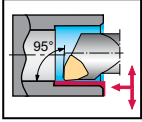

## Tool

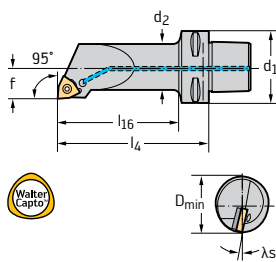

Walter Capto™ in acc. with ISO 26623

Designation		d <sub>1</sub>	D <sub>min</sub> mm	d <sub>2</sub> mm	f mm	l <sub>4</sub> mm	l <sub>16</sub> mm	γ	λ <sub>s</sub>	Type	
C3-PWLNR-13075-06		6	C3	25	20	13	75	58	-6°	-15°	WN .. 0604 ..
C4-PWLNR-13075-06		6	C4	25	20	13	75	52	-6°	-15°	
C4-PWLNR-17090-06		6	C4	32	25	17	90	68	-6°	-10°	
C4-PWLNR-17090-08		8	C4	32	25	17	90	67	-6°	-10°	WN .. 0804 ..
C4-PWLNR-22110-08		8	C4	40	32	22	110	89	-6°	-10°	
C4-PWLNR-27120-08		8	C4	50	40	27	120	100	-6°	-10°	
C5-PWLNR-17090-08		8	C5	32	25	17	90	67	-6°	-10°	
C5-PWLNR-22110-08		8	C5	40	32	22	110	88	-6°	-14°	
C5-PWLNR-27140-08		8	C5	50	40	27	140	119	-6°	-10°	
C6-PWLNR-27140-08		8	C6	50	40	27	140	115	-6°	-10°	
C6-PWLNR-35175-08		8	C6	63	50	35	175	152	-6°	-10°	
C3-PWLNL-13075-06		6	C3	25	20	13	75	58	-6°	-15°	WN .. 0604 ..
C4-PWLNL-13075-06		6	C4	25	20	13	75	52	-6°	-15°	
C4-PWLNL-17090-06		6	C4	32	25	17	90	68	-6°	-12°	
C4-PWLNL-17090-08		8	C4	32	25	17	90	69	-6°	-14°	WN .. 0804 ..
C4-PWLNL-22110-08		8	C4	40	32	22	110	89	-6°	-10°	
C4-PWLNL-27120-08		8	C4	50	40	27	120	100	-6°	-10°	
C5-PWLNL-17090-08		8	C5	32	25	17	90	67	-6°	-10°	
C5-PWLNL-22110-08		8	C5	40	32	22	110	88	-6°	-14°	
C5-PWLNL-27140-08		8	C5	50	40	27	140	119	-6°	-10°	
C6-PWLNL-27140-08		8	C6	50	40	27	140	115	-6°	-10°	
C6-PWLNL-35175-08		8	C6	63	50	35	175	152	-6°	-10°	

Dimensional drawing shows right-hand version. | Measured with master insert: WN .. 060408 / WN .. 080408 | Refer to the Walter online catalogue for more product information: [www.walter-tools.com](http://www.walter-tools.com) | Bodies and assembly parts are included in the scope of delivery

## Assembly parts

Type	D <sub>min</sub> [mm]	WN .. 0604 .. 25–32	WN .. 0804 .. 32	WN .. 0804 .. 40	WN .. 0804 .. 50–63
	Shim			AP170-WN0816	AP170-WN0816
	Lever	KN108	KN109	KN121	KN102
	Clamping screw Tightening torque	FS331 (SW 2) 2 Nm	FS332 (SW 2,5) 2,5 Nm	FS2129 (SW 3) 5 Nm	FS352 (SW 3) 5 Nm
	Shim pin			RS102	RS102
	Tapered assembly pin			MD101	MD101
	Allen key	ISO2936-2 (SW 2)	ISO2936-2,5 (SW 2,5)	ISO2936-3 (SW 3)	ISO2936-3 (SW 3)

## Accessories

Type	WN .. 0604 ..	WN .. 0804 ..
		AP170-WN0808

## Boring bar – Screw clamping

C...-SCLC 

## Walter Turn

– Walter Capto™

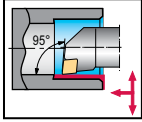

## Tool

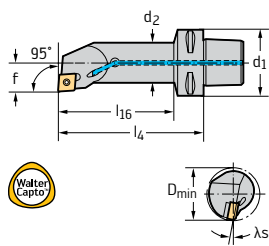

Walter Capto™ in acc. with ISO 26623

Designation		d <sub>1</sub>	D <sub>min</sub> mm	d <sub>2</sub> mm	f mm	l <sub>4</sub> mm	l <sub>16</sub> mm	γ	λ <sub>s</sub>	Type	
C3-SCLCR-11065-09		9	C3	20	16	11	65	48	0°	-8,4°	CC .. 09T3 ..
C3-SCLCR-17090-09		9	C3	32	25	17	90	74	0°	-3,4°	
C4-SCLCR-11070-09		9	C4	20	16	11	70	47	0°	-8,4°	
C4-SCLCR-13080-09		9	C4	25	20	13	80	57	0°	-5,8°	
C4-SCLCR-17090-09		9	C4	32	25	17	90	68	0°	-3,4°	
C5-SCLCR-11070-09		9	C5	20	16	11	70	46	0°	-8,4°	
C5-SCLCR-13080-09		9	C5	25	20	13	80	56	0°	-5,8°	
C5-SCLCR-17090-09		9	C5	32	25	17	90	67	0°	-3,4°	
C4-SCLCR-17090-12		12	C4	32	25	17	90	68	0°	-4,6°	CC .. 1204 ..
C5-SCLCR-22110-12		12	C5	40	32	22	110	88	0°	-9,8°	
C5-SCLCR-27140-12		12	C5	50	40	27	140	119	0°	-7,2°	
C3-SCLCL-11065-09		9	C3	20	16	11	65	48	0°	-8,4°	CC .. 09T3 ..
C3-SCLCL-17090-09		9	C3	32	25	17	90	74	0°	-3,4°	
C4-SCLCL-11070-09		9	C4	20	16	11	70	47	0°	-8,4°	
C4-SCLCL-13080-09		9	C4	25	20	13	80	57	0°	-5,8°	
C4-SCLCL-17090-09		9	C4	32	25	17	90	68	0°	-3,4°	
C5-SCLCL-11070-09		9	C5	20	16	11	70	46	0°	-8,5°	
C5-SCLCL-13080-09		9	C5	25	20	13	80	56	0°	-5,8°	
C5-SCLCL-17090-09		9	C5	32	25	17	90	67	0°	-3,4°	
C4-SCLCL-17090-12		12	C4	32	25	17	90	68	0°	-4,6°	CC .. 1204 ..
C5-SCLCL-22110-12		12	C5	40	32	22	110	88	0°	-9,8°	
C5-SCLCL-27140-12		12	C5	50	40	27	140	119	0°	-7,2°	

Dimensional drawing shows right-hand version. | Measured with master insert: CC .. 09T308 / CC .. 120408 | Refer to the Walter online catalogue for more product information: [www.walter-tools.com](http://www.walter-tools.com) | Bodies and assembly parts are included in the scope of delivery

## Assembly parts

Type	D <sub>min</sub> [mm]	CC .. 09T3 .. 20–25	CC .. 09T3 .. 32	CC .. 1204 .. 32	CC .. 1204 .. 40–50
	Clamping screw for indexable insert Tightening torque	FS2062 (T15IP) 3 Nm	FS2063 (T15IP) 3 Nm	FS2064 (T15IP) 3 Nm	FS2065 (T15IP) 3 Nm
	Shim				AP314-CC1212
	Screw for shim				FS2069 (SW 4)
	Torx key	FS1465 (T15IP)	FS1465 (T15IP)	FS1496 (T15IP)	FS1496 (T15IP)



## Boring bar – Screw clamping

C...-SDUC 

## Walter Turn

– Walter Capto™

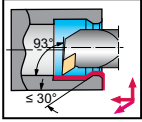

## Tool

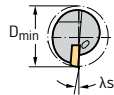
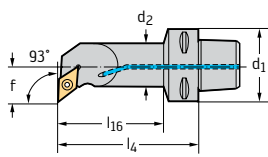

Walter Capto™ in acc. with ISO 26623

Designation		d <sub>1</sub>	D <sub>min</sub> mm	d <sub>2</sub> mm	f mm	l <sub>4</sub> mm	l <sub>16</sub> mm	γ	λ <sub>s</sub>	Type	
C3-SDUCR-11065-07		7	C3	20	16	11	65	48	0°	-4,3°	DC .. 0702 ..
C4-SDUCR-11070-07		7	C4	20	16	11	70	47	0°	-4,3°	
C5-SDUCR-11070-07		7	C5	20	16	11	70	46	0°	-4,3°	
C3-SDUCR-13075-11		11	C3	25	20	13	75	58	0°	-5,8°	DC .. 11T3 ..
C3-SDUCR-17090-11		11	C3	32	25	17	90	73	0°	-3,4°	
C4-SDUCR-13080-11		11	C4	25	20	13	80	57	0°	-5,8°	
C4-SDUCR-17090-11		11	C4	32	25	17	90	68	0°	-3,4°	DC .. 11T3 ..
C4-SDUCR-22110-11		11	C4	40	32	22	110	89	0°	-7,6°	
C4-SDUCR-27080-11		11	C4	50	40	27	80	60	0°	-5,4°	
C5-SDUCR-13080-11		11	C5	25	20	13	80	56	0°	-5,8°	DC .. 11T3 ..
C5-SDUCR-17090-11		11	C5	32	25	17	90	67	0°	-3,4°	
C5-SDUCR-22110-11		11	C5	40	32	22	110	88	0°	-7,6°	
C3-SDUCL-11065-07		7	C3	20	16	11	65	48	0°	-4,3°	DC .. 0702 ..
C4-SDUCL-11070-07		7	C4	20	16	11	70	47	0°	-4,3°	
C5-SDUCL-11070-07		7	C5	20	16	11	70	46	0°	-4,3°	
C3-SDUCL-13075-11		11	C3	25	20	13	75	58	0°	-5,8°	DC .. 11T3 ..
C3-SDUCL-17090-11		11	C3	32	25	17	90	73	0°	-3,4°	
C4-SDUCL-13080-11		11	C4	25	20	13	80	57	0°	-5,8°	
C4-SDUCL-17090-11		11	C4	32	25	17	90	68	0°	-3,4°	DC .. 11T3 ..
C4-SDUCL-22110-11		11	C4	40	32	22	110	89	0°	-7,6°	
C4-SDUCL-27080-11		11	C4	50	40	27	80	60	0°	-5,4°	
C5-SDUCL-13080-11		11	C5	25	20	13	80	56	0°	-5,8°	DC .. 11T3 ..
C5-SDUCL-17090-11		11	C5	32	25	17	90	67	0°	-3,4°	
C5-SDUCL-22110-11		11	C5	40	32	22	110	88	0°	-7,6°	

Dimensional drawing shows right-hand version. | Measured with master insert: DC .. 070204 / DC .. 11T308 | Refer to the Walter online catalogue for more product information: [www.walter-tools.com](http://www.walter-tools.com) | Bodies and assembly parts are included in the scope of delivery

## Assembly parts

Type	D <sub>min</sub> [mm]	DC .. 0702 .. 20	DC .. 11T3 .. 25	DC .. 11T3 .. 32	DC .. 11T3 .. 40–50
Clamping screw for indexable insert Tightening torque		FS2061 (T7IP) 0,9 Nm	FS2062 (T15IP) 3 Nm	FS2063 (T15IP) 3 Nm	FS2060 (T15IP) 3 Nm
Shim					AP315-DC1108
Screw for shim					FS2068 (SW 3,5)
Torx key		FS1490 (T7IP)	FS1465 (T15IP)	FS1465 (T15IP)	FS1465 (T15IP)

## Boring bar – Screw clamping

C...-STFC

### Walter Turn

– Walter Capto™

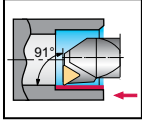

#### Tool

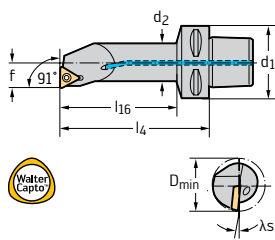

Walter Capto™ in acc. with ISO 26623

Designation		d <sub>1</sub>	D <sub>min</sub> mm	d <sub>2</sub> mm	f mm	l <sub>4</sub> mm	l <sub>16</sub> mm	γ	λ <sub>s</sub>	Type
C4-STFCR-11070-11	11	C4	20	16	11	70	47	0°	-12°	TC .. 1102 ..
C5-STFCR-11070-11	11	C5	20	16	11	70	46	0°	-12°	
C5-STFCR-13080-11	11	C5	25	20	13	80	56	0°	-3°	TC .. 16T3 ..
C4-STFCR-17090-16	16	C4	32	25	17	90	68	0°	-3,4°	
C4-STFCR-22110-16	16	C4	40	32	22	110	89	0°	-7,9°	TC .. 16T3 ..
C5-STFCR-17090-16	16	C5	32	25	17	90	67	0°	-3,4°	
C5-STFCR-22110-16	16	C5	40	32	22	110	88	0°	-7,9°	TC .. 1102 ..
C4-STFCL-11070-11	11	C4	20	16	11	70	47	0°	-12°	
C5-STFCL-11070-11	11	C5	20	16	11	70	46	0°	-12°	TC .. 16T3 ..
C5-STFCL-13080-11	11	C5	25	20	13	80	56	0°	-10,3°	
C4-STFCL-17090-16	16	C4	32	25	17	90	68	0°	-3,4°	TC .. 16T3 ..
C4-STFCL-22110-16	16	C4	40	32	22	110	89	0°	-7,9°	
C5-STFCL-17090-16	16	C5	32	25	17	90	67	0°	-3,4°	TC .. 16T3 ..
C5-STFCL-22110-16	16	C5	40	32	22	110	88	0°	-7,9°	

Dimensional drawing shows right-hand version. | Measured with master insert: TC .. 110204 / TC .. 16T308 | Refer to the Walter online catalogue for more product information: [www.walter-tools.com](http://www.walter-tools.com) | Bodies and assembly parts are included in the scope of delivery

#### Assembly parts

	Type D <sub>min</sub> [mm]	TC .. 1102 .. 20–25	TC .. 16T3 .. 32	TC .. 16T3 .. 40
	Clamping screw for indexable insert Tightening torque	FS2061 (T7IP) 0,9 Nm	FS2063 (T15IP) 3 Nm	FS2060 (T15IP) 3 Nm
	Shim			AP317-TC1612
	Screw for shim			FS2068 (SW 3,5)
	Torx key	FS1490 (T7IP)	FS1465 (T15IP)	FS1465 (T15IP)

## Boring bar – Screw clamping

C...-SVQB 

Walter Turn

– Walter Capto™

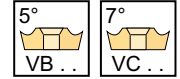
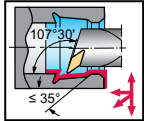

## Tool

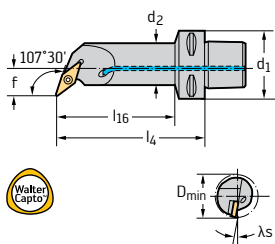

Walter Capto™ in acc. with ISO 26623

Designation		d <sub>1</sub>	D <sub>min</sub> mm	d <sub>2</sub> mm	f mm	l <sub>4</sub> mm	l <sub>16</sub> mm	γ	λ <sub>s</sub>	Type	
C3-SVQBR-13070-11		11	C3	22	16	13	70	53	0°	-6,9°	VB .. 1103 ..
C4-SVQBR-13070-11		11	C4	25	20	13	70	47	0°	-5,7°	
C4-SVQBR-15080-11		11	C4	27	20	15	80	57	0°	-5°	
C5-SVQBR-15080-11		11	C5	27	20	15	80	56	0°	-5°	VB .. 1604 ..
C4-SVQBR-18090-16		16	C4	33	25	18	90	68	0°	-7,2°	
C4-SVQBR-22110-16		16	C4	40	32	22	110	89	0°	-10,9°	
C4-SVQBR-27080-16		16	C4	50	40	27	80	60	0°	-7,9°	VB .. 1604 ..
C4-SVQBR-27120-16		16	C4	50	40	27	120	100	0°	-7,9°	
C5-SVQBR-18090-16		16	C5	33	25	18	90	67	0°	-7,2°	
C5-SVQBR-22110-16		16	C5	40	32	22	110	88	0°	-10,9°	VB .. 1604 ..
C5-SVQBR-27140-16		16	C5	50	40	27	140	119	0°	-7,9°	
C5-SVQBR-35150-16		16	C5	63	50	35	150	130	0°	-5,4°	
C6-SVQBR-22120-16		16	C6	40	32	22	120	94	0°	-10,9°	VB .. 1604 ..
C6-SVQBR-27145-16		16	C6	50	40	27	145	120	0°	-7,9°	
C6-SVQBR-35175-16		16	C6	63	50	35	175	151	0°	-5,4°	
C3-SVQBL-13070-11		11	C3	22	16	13	70	53	0°	-6,9°	VB .. 1103 ..
C4-SVQBL-13070-11		11	C4	25	20	13	70	48	0°	-5,7°	
C4-SVQBL-15080-11		11	C4	27	20	15	80	57	0°	-5°	
C5-SVQBL-15080-11		11	C5	27	20	15	80	56	0°	-5°	VB .. 1604 ..
C4-SVQBL-18090-16		16	C4	33	25	18	90	68	0°	-7,2°	
C4-SVQBL-22110-16		16	C4	40	32	22	110	89	0°	-10,9°	
C4-SVQBL-27080-16		16	C4	50	40	27	80	60	0°	-7,9°	VB .. 1604 ..
C4-SVQBL-27120-16		16	C4	50	40	27	120	100	0°	-7,9°	
C5-SVQBL-18090-16		16	C5	33	25	18	90	67	0°	-7,2°	
C5-SVQBL-22110-16		16	C5	40	32	22	110	88	0°	-10,9°	VB .. 1604 ..
C5-SVQBL-27140-16		16	C5	50	40	27	140	119	0°	-7,9°	
C5-SVQBL-35150-16		16	C5	63	50	35	150	130	0°	-5,4°	
C6-SVQBL-22120-16		16	C6	40	32	22	120	94	0°	-10,9°	VB .. 1604 ..
C6-SVQBL-27145-16		16	C6	50	40	27	145	120	0°	-7,9°	
C6-SVQBL-35175-16		16	C6	63	50	35	175	151	0°	-5,4°	

Dimensional drawing shows right-hand version. | Measured with master insert: VB .. 110304 / VB .. 160408 | Refer to the Walter online catalogue for more product information: [www.walter-tools.com](http://www.walter-tools.com) | Bodies and assembly parts are included in the scope of delivery

## Assembly parts

Type	D <sub>min</sub> [mm]	VB .. 1103 .. 22–27	VB .. 1604 .. 33	VB .. 1604 .. 40–63
	Clamping screw for indexable insert Tightening torque	FS2172 (T7IP) 0,9 Nm	FS2063 (T15IP) 3 Nm	FS2060 (T15IP) 3 Nm
	Shim		AP316-VB1608	AP316-VB1608
	Screw for shim		FS2068 (SW 3,5)	FS2068 (SW 3,5)
	Torx key	FS1490 (T7IP)	FS1465 (T15IP)	FS1465 (T15IP)

## Accessories

Type	VB .. 1103 ..	VB .. 1604 ..
		AP330-VB1612

## Cylinder shaft adaptor – vibration damped

**A3000** 
**Accure-tec®**

- For QuadFit exchangeable heads
- With preset vibration damping



Tool	Designation	d <sub>1</sub> mm	d <sub>11</sub>	l <sub>4</sub> mm	l <sub>5</sub> mm	l <sub>1</sub> mm	d <sub>13</sub>	kg
 Parallel shank with clamping surface	A3000-25-Q25-130	25	Q25	130	100	234,5	G 1/4	1,1
	A3000-32-Q32-160	32	Q32	160	128	293,4	G 1/4	1,8
	A3000-32-Q32-224	32	Q32	224	128	357,4	G 1/4	6
	A3000-40-Q40-208	40	Q40	208	160	374,4	G 1/4	3,8
	A3000-40-Q40-288	40	Q40	288	160	454,4	G 1/4	4,6
	A3000-50-Q50-268	50	Q50	268	200	475,4	G 1/4	7,5
	A3000-50-Q50-368	50	Q50	368	200	575,4	G 1/4	9,1
 Cylindrical shank	A3000-25-Q25-180	25	Q25	180	100	284,5	G 1/4	1,1
	A3000-25-Q25-230-CS	25	Q25	230	75	309,5	M8X1	1,7
	A3000-32-Q32-288-CS	32	Q32	288	98	389,4	M8X1	2,7
	A3000-40-Q40-368	40	Q40	368	160	534,4	G 1/4	5,5
	A3000-50-Q50-468	50	Q50	468	200	675,4	G 1/4	11

A3000...-CS = Carbide reinforced version | Refer to the Walter online catalogue for more product information: [www.walter-tools.com](http://www.walter-tools.com) | Bodies and assembly parts are included in the scope of delivery

Assembly parts		d <sub>11</sub>	Q25	Q32	Q40	Q50
	Hook wrench Tightening torque		SD9000-Q25 25 Nm	SD9000-Q32 25 Nm	SD9000-Q40 35 Nm	SD9000-Q50 55 Nm
	Coolant adaptor for CS variant		CN3001-M8-G1/4	CN3001-M8-G1/4		

Accessories		d <sub>11</sub>	Q25	Q32	Q40	Q50
	Torque wrench with hook			SD4000-Q32-25 (Q32) 25 Nm	SD4000-Q40-35 (Q40) 35 Nm	SD4000-Q50-55 (Q50) 55 Nm
	Hook for torque wrench			SD6000-Q32 (Q32) 25 Nm	SD6000-Q40 (Q40) 35 Nm	SD6000-Q50 (Q50) 55 Nm

# Cylinder shaft adaptor – vibration damped

A3000 inch

**Accure-tec®**

- For QuadFit exchangeable heads
- With preset vibration damping



Tool		Designation	d <sub>1</sub> inch	d <sub>11</sub>	l <sub>4</sub> inch	l <sub>5</sub> inch	l <sub>1</sub> inch	d <sub>13</sub>	lbs
<p>Parallel shank with clamping surface</p>		A3000.16-Q25-133	1,000	Q25	5,250	4,000	9,430	G 1/4	4,365
		A3000.20-Q32-165	1,250	Q32	6,500	5,000	11,713	G 1/4	3,968
		A3000.20-Q32-229	1,250	Q32	9,000	5,000	14,213	G 1/4	5,071
		A3000.24-Q40-203	1,500	Q40	8,000	6,000	14,252	G 1/4	7,716
		A3000.24-Q40-279	1,500	Q40	11,000	6,000	17,252	G 1/4	9,480
		A3000.32-Q50-267	2,000	Q50	10,500	8,000	18,791	G 1/4	16,755
		A3000.32-Q50-368	2,000	Q50	14,496	8,000	22,791	G 1/4	20,283
<p>Parallel shank with clamping surface</p>		A3000.16-Q25-184	1,000	Q25	7,250	4,000	11,430	G 1/4	5,357
		A3000.16-Q25-235-CS	1,000	Q25	9,250	3,000	12,430	M8X1	8,752
		A3000.20-Q32-292-CS	1,250	Q32	11,500	3,750	15,463	M8X1	13,118
		A3000.24-Q40-356	1,500	Q40	14,000	6,000	20,252	G 1/4	11,464
		A3000.32-Q50-470	2,000	Q50	18,500	8,000	26,791	G 1/4	24,692

A3000...-CS = Carbide reinforced version | Refer to the Walter online catalogue for more product information: [www.walter-tools.com](http://www.walter-tools.com) | Bodies and assembly parts are included in the scope of delivery

Assembly parts		d <sub>11</sub>	Q25	Q32	Q40	Q50
	Hook wrench Tightening torque		SD9000-Q25 18,439 lbs	SD9000-Q32 18,439 lbs	SD9000-Q40 25,815 lbs	SD9000-Q50 40,566 lbs
	Coolant adaptor for CS variant		CN3001-M8-G1/4	CN3001-M8-G1/4		

Accessories		d <sub>11</sub>	Q25	Q32	Q40	Q50
	Torque wrench with hook			SD4000-Q32-25 (Q32) 18,439 lbs	SD4000-Q40-35 (Q40) 25,815 lbs	SD4000-Q50-55 (Q50) 40,566 lbs
	Hook for torque wrench			SD6000-Q32 (Q32) 18,439 lbs	SD6000-Q40 (Q40) 25,815 lbs	SD6000-Q50 (Q50) 40,566 lbs

## Cylinder shaft adaptor – vibration damped

**A3001** 
**Accure-tec®**

- For A2201 intermediate adaptor with QuadFit interface
- With preset vibration damping

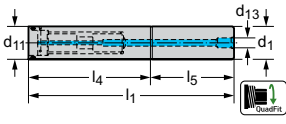

### Tool

	Designation	d <sub>1</sub> mm	d <sub>11</sub>	l <sub>4</sub> mm	l <sub>5</sub> mm	l <sub>1</sub> mm	d <sub>13</sub>	kg
	A3001-60-QL60-301	60	QL60	301	240	541	G 3/4	12,5
	A3001-60-QL60-541	60	QL60	541	240	781	G 3/4	18,1
	A3001-80-QL80-421	80	QL80	421	320	741	G 3/4	30,2
	A3001-80-QL80-741	80	QL80	741	320	1.061	G 3/4	43,4
	Cylindrical shank A3001-100-QL100-939	100	QL100	939	500	1.439	G 3/4	84,7

Refer to the Walter online catalogue for more product information: [www.walter-tools.com](http://www.walter-tools.com) | Bodies and assembly parts are included in the scope of delivery

### Assembly parts

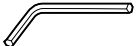
	d <sub>11</sub>	QL100	QL60	QL80
	Threaded plug	FS2611 (SW 6)	FS2609 (SW 4)	FS2610 (SW 5)
	Allen key	ISO2936-6 (SW 6)	ISO2936-4 (SW 4)	ISO2936-5 (SW 5)

## Cylinder shaft adaptor – vibration damped

A3001 inch

**Accure-tec®**

- For A2201 intermediate adaptor with QuadFit interface
- With preset vibration damping

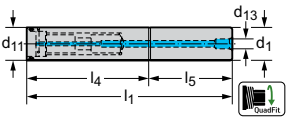

Tool	Designation	d <sub>1</sub> inch	d <sub>11</sub>	l <sub>4</sub> inch	l <sub>5</sub> inch	l <sub>1</sub> inch	d <sub>13</sub>	lbs
	A3001.40-QL64-318	2,500	QL64	12,500	10,000	22,500	G 3/4	32,408
	A3001.40-QL64-572	2,500	QL64	22,500	10,000	32,500	G 3/4	46,738
	A3001.48-QL76-394	3,000	QL74	15,500	12,000	27,500	G 3/4	57,32
	A3001.48-QL76-699	3,000	QL74	27,500	12,000	39,500	G 3/4	83,114
	A3001.64-QL100-953	4,000	QL100	37,500	20,000	57,500	G 3/4	195,55

Refer to the Walter online catalogue for more product information: [www.walter-tools.com](http://www.walter-tools.com) | Bodies and assembly parts are included in the scope of delivery

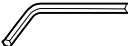
Assembly parts		d <sub>11</sub>	QL100	QL64	QL74
	Threaded plug		FS2611 (SW 6)	FS2609 (SW 4)	FS2610 (SW 5)
	Allen key		ISO2936-6 (SW 6)	ISO2936-4 (SW 4)	ISO2936-5 (SW 5)

# Walter Capto™ Adaptor – vibration damped

## A3000-C

### Accure-tec®

- For QuadFit exchangeable heads
- With preset vibration damping



Tool	Designation	d <sub>1</sub>	d <sub>11</sub>	d <sub>12</sub> mm	l <sub>4</sub> mm	l <sub>16</sub> mm	l <sub>17</sub> mm	kg
<p>Walter Capto™ in acc. with ISO 26623</p>	A3000-C4-Q25-130	C4	Q25	25	130	107	110	0,8
	A3000-C4-Q25-180	C4	Q25	25	180	157	160	1
	A3000-C4-Q32-160	C4	Q32	32	160	134	140	1,2
	A3000-C4-Q32-224	C4	Q32	32	224	198	204	1,7
	A3000-C5-Q25-130	C5	Q25	25	130	107	110	2,9
	A3000-C5-Q25-180	C5	Q25	25	180	157	160	1,1
	A3000-C5-Q25-230	C5	Q25	25	230	207	210	3,9
	A3000-C5-Q32-160	C5	Q32	32	160	133	140	1,4
	A3000-C5-Q32-224	C5	Q32	32	224	197	204	4,4
	A3000-C5-Q32-288	C5	Q32	32	288	261	268	2,2
	A3000-C5-Q40-208	C5	Q40	40	208	181	188	2,5
	A3000-C5-Q40-288	C5	Q40	40	288	261	268	3,3
	A3000-C6-Q25-130	C6	Q25	25	130	102	105	1,3
	A3000-C6-Q25-180	C6	Q25	25	180	152	155	1,5
	A3000-C6-Q25-230	C6	Q25	25	230	202	205	1,7
	A3000-C6-Q32-160	C6	Q32	32	160	129	135	1,9
	A3000-C6-Q32-224	C6	Q32	32	224	193	199	2,1
	A3000-C6-Q32-288	C6	Q32	32	288	257	263	2,6
	A3000-C6-Q40-208	C6	Q40	40	208	177	183	2,9
	A3000-C6-Q40-288	C6	Q40	40	288	257	263	3,7
	A3000-C6-Q40-368	C6	Q40	40	368	337	343	4,5
	A3000-C6-Q50-268	C6	Q50	50	268	238	243	5
	A3000-C6-Q50-368	C6	Q50	50	368	338	343	6,6
	A3000-C6-Q50-468	C6	Q50	50	468	438	443	8,5
	A3000-C8-Q32-224	C8	Q32	32	224	181	191	3,2
	A3000-C8-Q32-288	C8	Q32	32	288	245	255	3,6
	A3000-C8-Q40-288	C8	Q40	40	288	245	255	4,7
	A3000-C8-Q40-368	C8	Q40	40	368	325	335	5,6
	A3000-C8-Q50-268	C8	Q50	50	268	225	235	5,9
	A3000-C8-Q50-368	C8	Q50	50	368	325	335	7,5
	A3000-C8-Q50-468	C8	Q50	50	468	425	435	9,4

Refer to the Walter online catalogue for more product information: [www.walter-tools.com](http://www.walter-tools.com) | Bodies and assembly parts are included in the scope of delivery

### Assembly parts

	d <sub>11</sub>	Q25	Q32	Q40	Q50
	Hook wrench Tightening torque	SD9000-Q25 25 Nm	SD9000-Q32 25 Nm	SD9000-Q40 35 Nm	SD9000-Q50 55 Nm

### Accessories

	d <sub>11</sub>	Q25	Q32	Q40	Q50
	Torque wrench with hook		SD4000-Q32-25 (Q32) 25 Nm	SD4000-Q40-35 (Q40) 35 Nm	SD4000-Q50-55 (Q50) 55 Nm
	Hook for torque wrench		SD6000-Q32 (Q32) 25 Nm	SD6000-Q40 (Q40) 35 Nm	SD6000-Q50 (Q50) 55 Nm



# Walter Capto™ Adaptor – vibration damped

## A3001-C

### Accure-tec®

- For A2201 intermediate adaptor with QuadFit interface
- With preset vibration damping



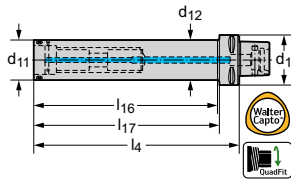

Tool		Designation	d <sub>1</sub>	d <sub>12</sub>	l <sub>4</sub> mm	l <sub>16</sub> mm	l <sub>17</sub> mm	kg
		A3001-C6-QL60-301	QL60	C6	301	273	276	7,8
		A3001-C6-QL60-421	QL60	C6	421	393	396	10,6
		A3001-C8-QL60-301	QL60	C8	301	263	268	8,6
		A3001-C8-QL60-421	QL60	C8	421	383	388	11,4
		A3001-C8-QL60-541	QL60	C8	541	503	508	14
		A3001-C8-QL80-421	QL80	C8	421	383	388	18,8
		A3001-C8-QL80-581	QL80	C8	581	543	548	25,1

Walter Capto™ in acc. with ISO 26623

Bodies and assembly parts are included in the scope of delivery

### Assembly parts

	d <sub>1</sub>	QL60	QL80
	Threaded plug	FS2609 (SW 4)	FS2610 (SW 5)
	Allen key	ISO2936-4 (SW 4)	ISO2936-5 (SW 5)

## HSK-T adaptor – vibration damped

### A3000-HSK-T

#### Accure-tec®

- For QuadFit exchangeable heads
- With preset vibration damping



Tool	Designation	d <sub>1</sub> mm	d <sub>11</sub>	d <sub>12</sub> mm	l <sub>4</sub> mm	l <sub>16</sub> mm	l <sub>17</sub> mm	kg
 HSK DIN 69893-7	A3000-H63T-Q25-130	63	Q25	25	130	101	104	1,1
	A3000-H63T-Q32-160	63	Q32	32	160	112	134	4,4
	A3000-H63T-Q25-180	63	Q25	25	180	151	154	1,3
	A3000-H63T-Q40-208	63	Q40	40	208	160	182	2,7
	A3000-H63T-Q32-224	63	Q32	32	224	176	198	2
	A3000-H63T-Q25-230	63	Q25	25	230	201	204	1,5
	A3000-H63T-Q50-268	63	Q50	50	268	225	242	4,8
	A3000-H63T-Q40-288	63	Q40	40	288	240	262	3,5
	A3000-H63T-Q50-368	63	Q50	50	368	325	342	6,4
	A3000-H100T-Q32-224	100	Q32	32	224	173	195	3,4
	A3000-H100T-Q50-268	100	Q50	50	268	218	239	6,2
	A3000-H100T-Q32-288	100	Q32	32	288	237	259	3,8
	A3000-H100T-Q40-288	100	Q40	40	288	237	259	4,9
	A3000-H100T-Q40-368	100	Q40	40	368	317	339	5,8
	A3000-H100T-Q50-368	100	Q50	50	368	318	339	7,8
	A3000-H100T-Q50-468	100	Q50	50	468	418	439	9,7

Refer to the Walter online catalogue for more product information: [www.walter-tools.com](http://www.walter-tools.com) | Bodies and assembly parts are included in the scope of delivery

Assembly parts					
	d <sub>11</sub>	Q25	Q32	Q40	Q50
	Hook wrench Tightening torque	SD9000-Q25 25 Nm	SD9000-Q32 25 Nm	SD9000-Q40 35 Nm	SD9000-Q50 55 Nm
Accessories					
	d <sub>11</sub>	Q25	Q32	Q40	Q50
	Torque wrench with hook		SD4000-Q32-25 (Q32) 25 Nm	SD4000-Q40-35 (Q40) 35 Nm	SD4000-Q50-55 (Q50) 55 Nm
	Hook for torque wrench		SD6000-Q32 (Q32) 25 Nm	SD6000-Q40 (Q40) 35 Nm	SD6000-Q50 (Q50) 55 Nm

## HSK-T adaptor – vibration damped

### A3001-HSK-T

#### Accure-tec®



- For A2201 intermediate adaptor with QuadFit interface
- With preset vibration damping

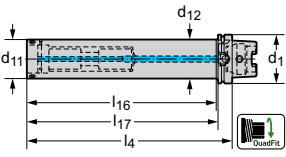

Tool		Designation	d <sub>1</sub>	d <sub>12</sub>	l <sub>4</sub> mm	l <sub>16</sub> mm	l <sub>17</sub> mm	
		A3001-H100T-QL60-301	QL60	100	301	267	272	8,9
		A3001-H100T-QL60-421	QL60	100	421	387	392	11,8
		A3001-H100T-QL60-541	QL60	100	541	507	512	14,5
		A3001-H100T-QL80-421	QL80	100	421	387	392	19,4
		A3001-H100T-QL80-581	QL80	100	581	547	552	26,2

HSK DIN 69893-7

Bodies and assembly parts are included in the scope of delivery

Assembly parts		d <sub>1</sub>	QL60	QL80
	Threaded plug		FS2609 (SW 4)	FS2610 (SW 5)
	Allen key		ISO2936-4 (SW 4)	ISO2936-5 (SW 5)

## Cylindrical shank - QuadFit

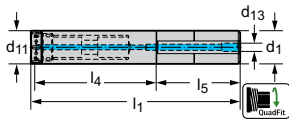

A2100 

– For QuadFit exchangeable heads

Tool	Designation	d <sub>1</sub> mm	d <sub>11</sub>	l <sub>4</sub> mm	l <sub>5</sub> mm	l <sub>1</sub> mm	d <sub>13</sub>	
	A2100-40-Q40-288	40	Q40	128	160	294,4	G 1/4	2,6
	A2100-50-Q50-368	50	Q50	168	200	375,4	G 1/4	5,5
	A2100-60-QL60-421	60	QL60	181	240	421	G 3/4	8,3

Parallel shank with clamping surface

Bodies and assembly parts are included in the scope of delivery

Assembly parts		d <sub>11</sub>	Q40	Q50	QL60
	Threaded plug				FS2609 (SW 4)
	Hook wrench Tightening torque		SD9000-Q40 35 Nm	SD9000-Q50 55 Nm	
	Allen key				ISO2936-4 (SW 4)

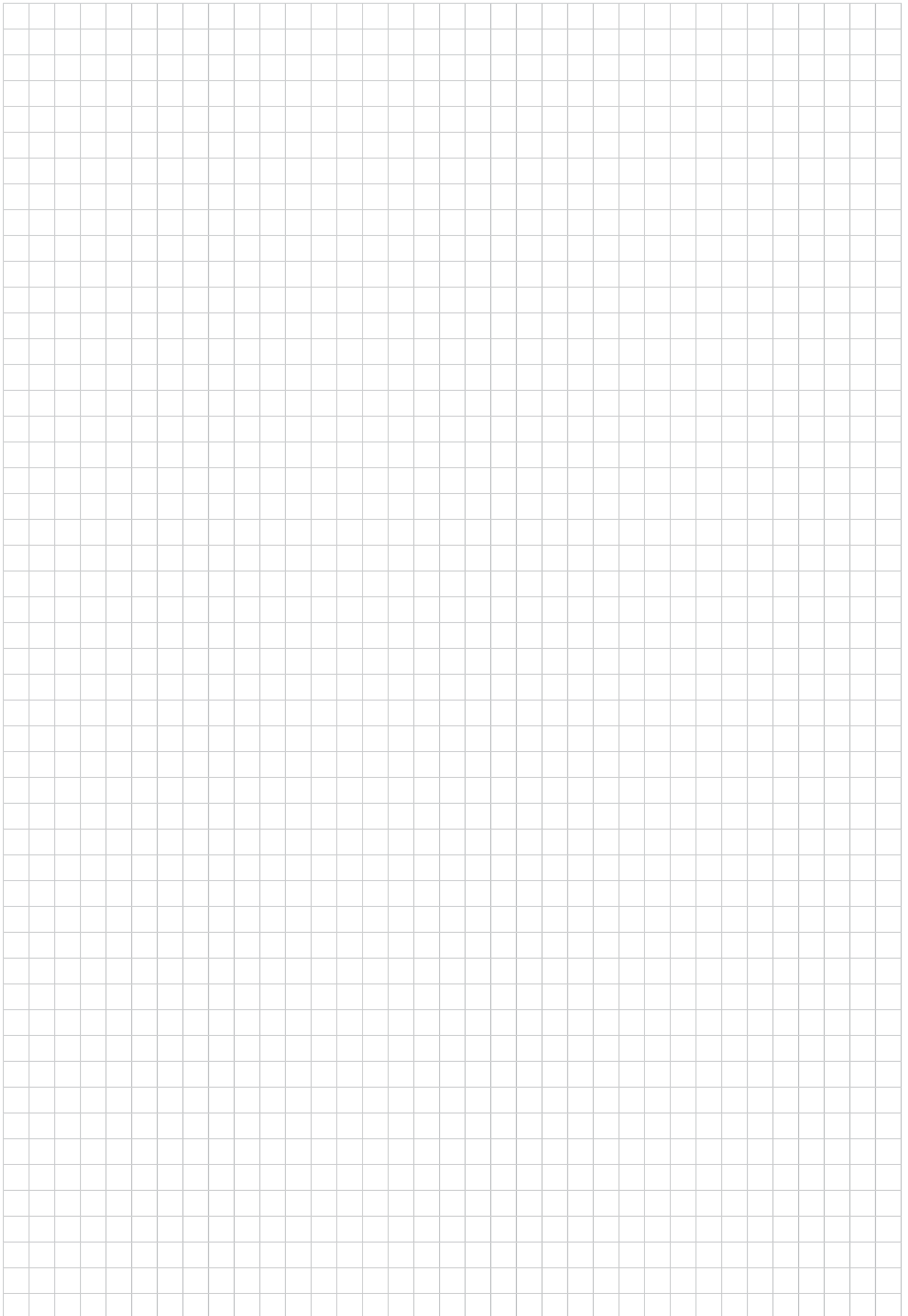

## QuadFit Large Intermediate adaptors

**A2201** 
**Accure-tec®**



- QuadFit
- For A3001 Accure-tec boring bars

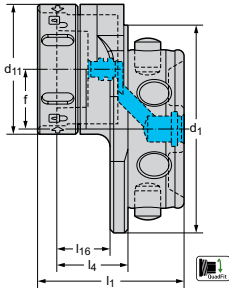

Tool	Designation	d <sub>11</sub>	d <sub>1</sub>	f mm	l <sub>1</sub> mm	l <sub>4</sub> mm	l <sub>16</sub> mm	
	A2201-QL60-05-27-Q50	Q50	QL60	5	50,4	27	21,5	0,6
	A2201-QL60-10-27-Q50	Q50	QL60	10	50,4	27	21,5	0,9
	A2201-QL80-15-27-Q50	Q50	QL80	15	56,4	27	21,5	0,9
	A2201-QL80-23-27-Q50	Q50	QL80	23	56,4	27	21,5	1,2
	A2201-QL100-28-29-Q50	Q50	QL100	28	61,4	29	21,5	1,5
	A2201-QL100-38-29-Q50	Q50	QL100	38	61,4	29	21,5	1,5

QuadFit

 Refer to the Walter online catalogue for more product information: [www.walter-tools.com](http://www.walter-tools.com) | Bodies and assembly parts are included in the scope of delivery

Assembly parts		d <sub>11</sub>	Q50
	Hook wrench Tightening torque		SD9000-Q50 55 Nm
Accessories		d <sub>11</sub>	Q50
	Torque wrench with hook		SD4000-Q50-55 (Q50) 55 Nm
	Hook for torque wrench		SD6000-Q50 (Q50) 55 Nm

## QuadFit Large Intermediate adaptors

A2201 inch

**Accure-tec®**



- QuadFit
- For A3001 Accure-tec boring bars

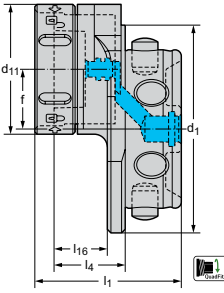

Tool	Designation	d <sub>11</sub>	d <sub>1</sub>	f inch	h <sub>1</sub> inch	l <sub>4</sub> inch	l <sub>16</sub> inch	
	A2201.QL64-07-27-Q50	Q50	QL64	0,266	1,988	1,063	0,846	2,205
	A2201.QL64-12-27-Q50	Q50	QL64	0,463	1,988	1,063	0,846	2,205
	A2201.QL76-13-27-Q50	Q50	QL76	0,516	2,228	1,063	0,846	2,205
	A2201.QL76-21-27-Q50	Q50	QL76	0,831	2,228	1,063	0,846	2,205

QuadFit

Refer to the Walter online catalogue for more product information: [www.walter-tools.com](http://www.walter-tools.com) | Bodies and assembly parts are included in the scope of delivery

Assembly parts		d <sub>11</sub>	Q50
	Hook wrench Tightening torque		SD9000-Q50 40,566 lbs
Accessories		d <sub>11</sub>	Q50
	Torque wrench with hook		SD4000-Q50-55 (Q50) 40,566 lbs
	Hook for torque wrench		SD6000-Q50 (Q50) 40,566 lbs

## Replaceable head – rigid clamping

Q...-DCLN

### Walter Turn

- QuadFit
- For Accure-tec boring bars

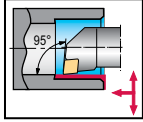

#### Tool

	Designation		$d_1$	$D_{min}$ mm	f mm	$l_4$ mm	$\gamma$	$\lambda_s$	Type
	Q32-DCLNR-22032-12	12	Q32	40	22	32	-6°	-10°	CN .. 1204 ..
	Q40-DCLNR-27032-12	12	Q40	50	27	32	-6°	-10°	
	Q50-DCLNR-32032-12	12	Q50	63	32	32	-6°	-8°	
	Q50-DCLNR-32037-16	16	Q50	63	32	37	-5°	-14°	CN .. 1606 ..
	Q32-DCLNL-22032-12	12	Q32	40	22	32	-6°	-10°	CN .. 1204 ..
	Q40-DCLNL-27032-12	12	Q40	50	27	32	-6°	-10°	
	Q50-DCLNL-32032-12	12	Q50	63	32	32	-6°	-8°	
	Q50-DCLNL-32037-16	16	Q50	63	32	37	-5°	-14°	CN .. 1606 ..

QuadFit

Dimensional drawing shows right-hand version. | Measured with master insert: CN .. 120408 / CN .. 160612 | Refer to the Walter online catalogue for more product information: [www.walter-tools.com](http://www.walter-tools.com) | Bodies and assembly parts are included in the scope of delivery

#### Assembly parts

	Type	CN .. 1204 ..	CN .. 1606 ..
	Shim	AP354-CN12	AP302-CN16
	Screw for shim Tightening torque	FS1461 (T15IP) 2,5 Nm	FS1463 (T20IP) 5 Nm
	Clamp	PK241	PK242
	Screw for clamp Tightening torque	FS1473 (T15IP) 3,9 Nm	FS1474 (T20IP) 6,4 Nm
	Pressure spring	FS1470	FS1471
	Pin	RS117	RS117
	Torx key	FS1465 (T15IP)	
	Allen key		FS1464 (T20IP)

#### Accessories

	Type	CN .. 1204 ..	CN .. 1606 ..
	(standard assembly parts) Clamp set	PK241-SET	PK242-SET
	Insert with hole Carbide clamp set	PK245-SET	PK246-SET
	Insert with hole Carbide clamp set	PK254-SET	



# Replaceable head – rigid clamping

Q...-DDUN mm

## Walter Turn

- QuadFit
- For Accure-tec boring bars

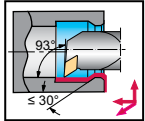

Tool			$d_1$	$D_{min}$ mm	f mm	$l_4$ mm	$\gamma$	$\lambda_s$	Type
	Q32-DDUNR-22032-11	11	Q32	40	22	32	-6°	-10°	DN .. 1104 ..
	Q40-DDUNR-27032-11	11	Q40	50	27	32	-5°	-10°	
	Q32-DDUNR-22032-15	15	Q32	40	21,9	32	-6°	-14°	DN .. 1506 ..
	Q40-DDUNR-27032-15	15	Q40	50	27	32	-6°	-12°	
	Q50-DDUNR-32032-15	15	Q50	63	32	32	-6°	-12°	
	Q32-DDUNL-22032-11	11	Q32	40	22	32	-6°	-10°	DN .. 1104 ..
	Q40-DDUNL-27032-11	11	Q40	50	27	32	-5°	-10°	
	Q32-DDUNL-22032-15	15	Q32	40	21,9	32	-6°	-14°	DN .. 1506 ..
	Q40-DDUNL-27032-15	15	Q40	50	27	32	-6°	-12°	
	Q50-DDUNL-32032-15	15	Q50	63	32	32	-6°	-12°	

Dimensional drawing shows right-hand version. | Measured with master insert: DN .. 110408 / DN .. 150608 | Refer to the Walter online catalogue for more product information: [www.walter-tools.com](http://www.walter-tools.com) | Bodies and assembly parts are included in the scope of delivery

Assembly parts		DN .. 1104 ..	DN .. 1506 ..
	Shim	AP305-DN11	AP304-DN15
	Screw for shim Tightening torque	FS1462 (T9IP) 1,5 Nm	FS1461 (T15IP) 2,5 Nm
	Clamp	PK240	PK241
	Screw for clamp Tightening torque	FS1472 (T9IP) 1,7 Nm	FS1473 (T15IP) 3,9 Nm
	Pressure spring	FS1469	FS1470
	Pin	RS116	RS117
	Torx key	FS1466 (T9IP)	FS1465 (T15IP)

Accessories		DN .. 1104 ..	DN .. 1506 ..
	(standard assembly parts) Clamp set	PK240-SET	PK241-SET
	Insert without hole Carbide clamp set		PK245-SET
	Insert without hole Carbide clamp set		PK254-SET
	Shim for DN .. 1504 ..		AP304-DN1504

## Replaceable head – rigid clamping

Q...-DWLN

### Walter Turn

- QuadFit
- For Accure-tec boring bars

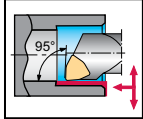

#### Tool

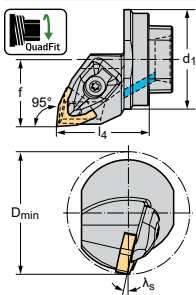

Designation		$d_1$	$D_{min}$ mm	$f$ mm	$l_4$ mm	$\gamma$	$\lambda_s$	Type
Q32-DWLN-22032-06	6	Q32	40	22	32	-5°	-12°	WN .. 0604 ..
Q32-DWLN-22035-08	8	Q32	40	22	35	-5°	-14°	WN .. 0804 ..
Q40-DWLN-27037-08	8	Q40	50	27	37	-5°	-12°	
Q50-DWLN-32038-08	8	Q50	63	32	38	-5°	-12°	
Q32-DWLN-22032-06	6	Q32	40	22	32	-5°	-12°	WN .. 0604 ..
Q32-DWLN-22035-08	8	Q32	40	22	35	-5°	-14°	WN .. 0804 ..
Q40-DWLN-27037-08	8	Q40	50	27	37	-5°	-12°	
Q50-DWLN-32038-08	8	Q50	63	32	38	-5°	-12°	

QuadFit

Dimensional drawing shows right-hand version. | Measured with master insert: WN .. 060408 / WN .. 080408 | Refer to the Walter online catalogue for more product information: [www.walter-tools.com](http://www.walter-tools.com) | Bodies and assembly parts are included in the scope of delivery

#### Assembly parts

Type	WN .. 0604 ..	WN .. 0804 ..
Shim	AP306-WN06	AP331-WN08
Screw for shim Tightening torque	FS1462 (T9IP) 1,5 Nm	FS1461 (T15IP) 2,5 Nm
Clamp	PK240	PK241
Screw for clamp Tightening torque	FS1472 (T9IP) 1,7 Nm	FS1473 (T15IP) 3,9 Nm
Pressure spring	FS1469	FS1470
Pin	RS116	RS117
Torx key	FS1466 (T9IP)	FS1465 (T15IP)

#### Accessories

Type	WN .. 0604 ..	WN .. 0804 ..
(standard assembly parts) Clamp set	PK240-SET	PK241-SET
Insert without hole Carbide clamp set		PK245-SET
Insert without hole Carbide clamp set		PK254-SET

# Replaceable head – screw clamping

Q...-SCLC

## Walter Turn

- QuadFit
- For Accure-tec boring bars

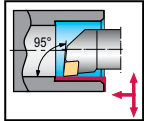

Tool			$d_1$	$D_{min}$ mm	$f$ mm	$l_4$ mm	$\gamma$	$\lambda_s$	Type
  QuadFit	Q25-SCLCR-17020-09	9	Q25	32	17	20	0°	-3°	CC .. 09T3 ..
	Q32-SCLCR-22032-09	9	Q32	40	22	32	0°	-2°	
	Q40-SCLCR-27032-09	9	Q40	50	27	32	0°	-2°	
	Q50-SCLCR-32032-09	9	Q50	63	32	32	0°	-2°	
	Q32-SCLCR-22032-12	12	Q32	40	22	32	0°	-8°	
	Q40-SCLCR-27032-12	12	Q40	50	27	32	0°	-8°	
	Q50-SCLCR-32032-12	12	Q50	63	32	32	0°	-9°	
	Q25-SCLCL-17020-09	9	Q25	32	17	20	0°	-3°	CC .. 09T3 ..
	Q32-SCLCL-22032-09	9	Q32	40	22	32	0°	-2°	
	Q40-SCLCL-27032-09	9	Q40	50	27	32	0°	-2°	
	Q50-SCLCL-32032-09	9	Q50	63	32	32	0°	-2°	
	Q32-SCLCL-22032-12	12	Q32	40	22	32	0°	-8°	
Q40-SCLCL-27032-12	12	Q40	50	27	32	0°	-8°		
Q50-SCLCL-32032-12	12	Q50	63	32	32	0°	-9°		

Dimensional drawing shows right-hand version. | Measured with master insert: CC .. 09T308 / CC .. 120408 | Refer to the Walter online catalogue for more product information: [www.walter-tools.com](http://www.walter-tools.com) | Bodies and assembly parts are included in the scope of delivery

Assembly parts		CC .. 09T3 ..	CC .. 1204 ..
	Clamping screw for indexable insert Tightening torque	FS1461 (T15IP) 2.5 Nm	FS2281 (T20IP) 5 Nm
	Shim		AP364-CC1208
	Screw for shim		FS2592 (SW 5)
	Torx key	FS1465 (T15IP)	
	Allen key		FS1464 (T20IP)
	Allen key for shim		ISO2936-5 (SW 5)

## Replaceable head – screw clamping

Q...-SDUC

### Walter Turn

- QuadFit
- For Accure-tec boring bars

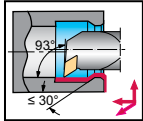

#### Tool

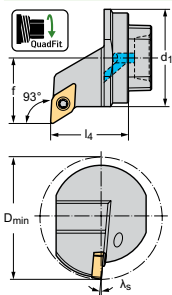

Designation



$d_1$

$D_{min}$   
mm

$f$   
mm

$l_4$   
mm

$\gamma$

$\lambda_s$

Type

Q25-SDUCR-17020-11	11	Q25	32	17	20	0°	-6°	DC .. 11T3 ..
Q32-SDUCR-22032-11	11	Q32	40	22	32	0°	-5°	
Q40-SDUCR-27032-11	11	Q40	50	27	32	0°	-5°	
Q50-SDUCR-32032-11	11	Q50	63	32	32	0°	-5°	
Q25-SDUCL-17020-11	11	Q25	32	17	20	0°	-6°	DC .. 11T3 ..
Q32-SDUCL-22032-11	11	Q32	40	22	32	0°	-5°	
Q40-SDUCL-27032-11	11	Q40	50	27	32	0°	-5°	
Q50-SDUCL-32032-11	11	Q50	63	32	32	0°	-5°	

QuadFit

Dimensional drawing shows right-hand version. | Measured with master insert: DC .. 11T308 | Refer to the Walter online catalogue for more product information: [www.walter-tools.com](http://www.walter-tools.com) | Bodies and assembly parts are included in the scope of delivery

#### Assembly parts

	Type	DC .. 11T3 ..
	Clamping screw for indexable insert Tightening torque	FS1461 (T15IP) 2,5 Nm
	Torx key	FS1465 (T15IP)

## Replaceable head – screw clamping

Q...-SDUC...-X

### Walter Turn

- QuadFit
- For Accure-tec boring bars

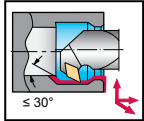

Tool		Designation		$d_1$	$D_{min}$ mm	f mm	$l_4$ mm	$l_{20}$ mm	$X_1$ mm	$\gamma$	$\lambda_s$	Type
		Q25-SDUCR-17012-11X	11	Q25	32	17	12	24,5	4,5	0°	-6°	DC .. 11T3 ..
		Q32-SDUCR-22018-11X	11	Q32	40	21,9	32	37,5	5,9	0°	-5°	
		Q40-SDUCR-27017-11X	11	Q40	50	26,9	17	40,5	6,9	0°	-5°	
		Q50-SDUCR-32017-11X	11	Q50	63	32	17	42,5	6,9	0°	-5°	
		Q25-SDUCL-17012-11X	11	Q25	32	17	12	24,5	4,5	0°	-6°	DC .. 11T3 ..
		Q32-SDUCL-22018-11X	11	Q32	40	21,9	18	37,5	5,9	0°	-5°	
		Q40-SDUCL-27017-11X	11	Q40	50	26,9	17	40,5	6,9	0°	-5°	
		Q50-SDUCL-32017-11X	11	Q50	63	32	17	42,5	6,9	0°	-5°	

QuadFit

Dimensional drawing shows right-hand version. | Measured with master insert: DC .. 11T308 | Refer to the Walter online catalogue for more product information: [www.walter-tools.com](http://www.walter-tools.com) | Bodies and assembly parts are included in the scope of delivery

Assembly parts		Type	DC .. 11T3 ..
	Clamping screw for indexable insert Tightening torque		FS1461 (T15IP) 2,5 Nm
	Torx key		FS1465 (T15IP)

## Replaceable head – screw clamping

Q...-SDXC

### Walter Turn

- QuadFit
- For Accure-tec boring bars

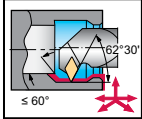

#### Tool

	Designation		d <sub>1</sub>	D <sub>min</sub> mm	f mm	l <sub>4</sub> mm	l <sub>20</sub> mm	X <sub>1</sub> mm	γ	λ <sub>s</sub>	Type
	Q25-SDXCR-17018-11	11	Q25	32	17	18	24,3	4,5	0°	-6°	DC .. 11T3 ..
	Q32-SDXCR-22025-11	11	Q32	40	21,9	25	37,5	5,9	0°	-5°	
	Q40-SDXCR-27025-11	11	Q40	50	26,9	25	40,5	6,9	0°	-5°	
	Q50-SDXCR-32025-11	11	Q50	63	31,9	25	42,5	6,9	0°	-5°	
	Q25-SDXCL-17018-11	11	Q25	32	17	18	24,3	4,5	0°	-6°	DC .. 11T3 ..
	Q32-SDXCL-22025-11	11	Q32	40	21,9	25	37,5	5,9	0°	-5°	
	Q40-SDXCL-27025-11	11	Q40	50	26,9	25	40,5	6,9	0°	-5°	
	Q50-SDXCL-32025-11	11	Q50	63	31,9	25	42,5	6,9	0°	-5°	

QuadFit

Dimensional drawing shows right-hand version. | Measured with master insert: DC .. 11T308 | Refer to the Walter online catalogue for more product information: [www.walter-tools.com](http://www.walter-tools.com) | Bodies and assembly parts are included in the scope of delivery

#### Assembly parts

	Type	DC .. 11T3 ..
	Clamping screw for indexable insert Tightening torque	FS1461 (T15IP) 2,5 Nm
	Torx key	FS1465 (T15IP)

# Replaceable head – screw clamping

Q...-STFC

## Walter Turn

- QuadFit
- For Accure-tec boring bars

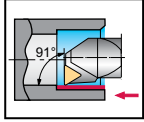

Tool			$d_1$	$D_{min}$ mm	$f$ mm	$l_4$ mm	$\gamma$	$\lambda_s$	Type
	Q25-STFCR-17020-11	11	Q25	32	17	20	0°	-3°	TC .. 1102 ..
	Q32-STFCR-22032-16	16	Q32	40	22	32	0°	-10°	TC .. 16T3 ..
	Q40-STFCR-27032-16	16	Q40	50	27	32	0°	-8°	
	Q50-STFCR-32032-16	16	Q50	63	32	32	0°	-8°	
	Q25-STFCL-17020-11	11	Q25	32	17	20	0°	-3°	TC .. 1102 ..
	Q32-STFCL-22032-16	16	Q32	40	22	32	0°	-10°	TC .. 16T3 ..
	Q40-STFCL-27032-16	16	Q40	50	27	32	0°	-8°	
	Q50-STFCL-32032-16	16	Q50	63	32	32	0°	-8°	

QuadFit

Dimensional drawing shows right-hand version. | Measured with master insert: TC .. 110200RE=0 / TC .. 16T308 | Refer to the Walter online catalogue for more product information: [www.walter-tools.com](http://www.walter-tools.com) | Bodies and assembly parts are included in the scope of delivery

Assembly parts		TC .. 1102 ..	TC .. 16T3 ..
	Clamping screw for indexable insert Tightening torque	FS2061 (T7IP) 0,9 Nm	FS2063 (T15IP) 3 Nm
	Shim		AP317-TC1612
	Screw for shim		FS2068 (SW 3,5)
	Torx key	FS1490 (T7IP)	FS1465 (T15IP)

## Replaceable head – screw clamping

Q...-SVUB

### Walter Turn

- QuadFit
- For Accure-tec boring bars

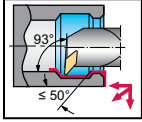
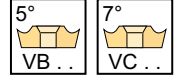

#### Tool

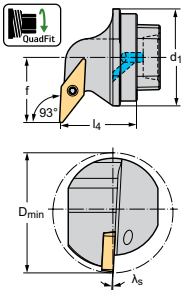

Designation		$d_1$	$D_{min}$ mm	$f$ mm	$l_4$ mm	$\gamma$	$\lambda_s$	Type
Q25-SVUBR-17020-11	11	Q25	32	17	20	0°	-4°	VB .. 1103 ..
Q32-SVUBR-22032-16	16	Q32	40	22	32	0°	-3°	VB .. 1604 ..
Q40-SVUBR-27032-16	16	Q40	50	26,9	32	0°	-3°	
Q50-SVUBR-32032-16	16	Q50	63	31,9	32	0°	-3°	
Q25-SVUBL-17020-11	11	Q25	32	17	20	0°	-4°	VB .. 1103 ..
Q32-SVUBL-22032-16	16	Q32	40	22	32	0°	-3°	VB .. 1604 ..
Q40-SVUBL-27032-16	16	Q40	50	26,9	32	0°	-3°	
Q50-SVUBL-32032-16	16	Q50	63	31,9	32	0°	-3°	

QuadFit

Dimensional drawing shows right-hand version. | Measured with master insert: VB .. 110304 / VB .. 160408 | Refer to the Walter online catalogue for more product information: [www.walter-tools.com](http://www.walter-tools.com) | Bodies and assembly parts are included in the scope of delivery

#### Assembly parts

Type	VB .. 1103 ..	VB .. 1604 ..
Clamping screw for indexable insert Tightening torque	FS2061 (T7IP) 0,9 Nm	FS2063 (T15IP) 3 Nm
Shim		AP316-VB1608
Screw for shim		FS2068 (SW 3,5)
Torx key	FS1490 (T7IP)	FS1465 (T15IP)



# Replaceable head – Copy turning system

W1211-Q...

Walter Turn



- Double internal coolant supply
- Additional coolant hole for blind hole machining

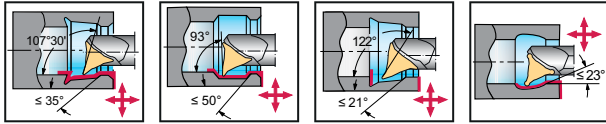

Tool			$d_1$	$D_{min}$ mm	$f$ mm	$l_c$ mm	$\gamma$	$\lambda_s$	Type
	W1211-Q32R-WL25	25	Q32	40	24	35	-1,8°	-3,7°	WL25..
	W1211-Q40R-WL25	25	Q40	50	29	35	-1,8°	-3,7°	
	W1211-Q50R-WL25	25	Q50	63	34	35	-1,8°	-3,7°	
	W1211-Q32L-WL25	25	Q32	40	24	35	-1,8°	-3,7°	WL25..
	W1211-Q40L-WL25	25	Q40	50	29	35	-1,8°	-3,7°	
	W1211-Q50L-WL25	25	Q50	63	34	35	-1,8°	-3,7°	

QuadFit





















Dimensional drawing shows right-hand version. | Measured with master insert:WL25-VC0708N-MM4 | The maximum recommended coolant pressure is 80 bar (1160 psi) | Refer to the Walter online catalogue for more product information: [www.walter-tools.com](http://www.walter-tools.com) | Bodies and assembly parts are included in the scope of delivery

Assembly parts	Type $d_1$	WL25.. Q32-Q50
	Clamping screw for indexable insert Tightening torque	FS1495 (T20IP) 5 Nm
	Allen key	FS1464 (T20IP)

WALTER  
SELECT

●● Primary application ● Other application  
Best tool for → Good = 😊 → Average = 😐 → Poor = 😞 machining conditions











## Cutting inserts











System	MX				
Machining	Low feed		Medium feed		
					
Geometry	GD8	VG8	CF5	RF5	A60
P Steel	●●	●●	●●	●●	●●
M Stainless steel	●●	●●	●●	●●	●●
K Cast iron	●	●	●	●	●
N NF metals	●●	●●	●●	●	●
S Materials with difficult cutting properties	●●	●●	●●	●●	●●
H Hard materials					
O Other			●		
Insert width s [mm]	0,5–3,25	2,8	0,8–5,0	1,57–5,0	
a <sub>p</sub> [mm]					
f [mm]	0,02–0,15	0,05–0,12	0,02–0,25	0,04–0,25	
Page in catalogue	A 376	A 378	A 377	A 379	A 380
QR code					
<a href="http://www.walter-tools.com/woc/">www.walter-tools.com/woc/</a>	GD8	VG8	CF5	RF5	A60
System	MX			DX	
Machining	Low feed				
		<b>NEW</b> 			
Geometry	AG60	ISO	-X..N	CK8	CF6
P Steel	●●	●●	●●	●●	●●
M Stainless steel	●●	●●	●●	●	●●
K Cast iron	●	●	●●	●	●●
N NF metals	●	●●	●●	●●	●●
S Materials with difficult cutting properties	●●	●●	●●	●	●●
H Hard materials			●●		
O Other			●		●
Insert width s [mm]			3,35–5,65	1,5–4,0	1,0–3,0
a <sub>p</sub> [mm]					
f [mm]				0,04–0,22	0,03–0,23
Page in catalogue	A 380	A 379	A 380	A 279	A 381
QR code					
<a href="http://www.walter-tools.com/woc/">www.walter-tools.com/woc/</a>	AG60	ISO	-X..N	CK8	CF6

WALTER SELECT

●● Primary application ● Other application

## Cutting inserts





System	DX				
Machining	Low feed				Medium feed
		<b>NEW</b> 			
Geometry	GD8	GD3	UF8	UF7	CF5
P Steel	●●	●●	●●	●●	●●
M Stainless steel	●●	●●	●●	●●	●●
K Cast iron	●	●	●	●	●
N NF metals	●●	●	●●	●	●●
S Materials with difficult cutting properties	●●	●	●●	●●	●●
H Hard materials					
O Other		●			●
Insert width s [mm]	1,0–1,4	2,0–4,0	1,6–4,25	2,0–4,0	1,0–3,0
a <sub>p</sub> [mm]			0,3–2,2	0,3–2,2	
f [mm]	0,05–0,10	0,04–0,23	0,05–0,30	0,05–0,30	0,03–0,23
Page in catalogue	A 279	A 381	A 279	A 279	A 381
QR code					
www.walter-tools.com/woc/	GD8	GD3	UF8	UF7	CF5

System	DX				
Machining	Medium feed				High feed
		<b>NEW</b> 			<b>NEW</b> 
Geometry	GD6	UF4	RF8	RF7	CE4
P Steel	●●	●●	●●	●●	●●
M Stainless steel	●●	●●	●●	●●	●
K Cast iron	●	●●	●	●	●●
N NF metals	●	●	●	●	●
S Materials with difficult cutting properties	●●	●	●●	●●	●
H Hard materials					●
O Other					
Insert width s [mm]	2,0–4,0	2,0–4,0	3,0	2,0–4,0	1,2–3,0
a <sub>p</sub> [mm]		0,3–2,8	0,1–1,0	0,1–2,0	
f [mm]	0,04–0,25	0,10–0,33	0,08–0,26	0,08–0,48	0,03–0,33
Page in catalogue	A 381	A 383	A 279	A 385	A 381
QR code					
www.walter-tools.com/woc/	GD6	UF4	RF8	RF7	CE4

WALTER SELECT

●● Primary application ● Other application

## Cutting inserts

System	DX			GD	
Machining	High feed			Low feed	
	<b>NEW</b> 	<b>NEW</b> 	<b>NEW</b> 	<b>NEW</b> 	<b>NEW</b> 
Geometry	UD4	UA4	RD4	CF6	GD3
P Steel	●●		●●	●●	●●
M Stainless steel	●		●	●●	●●
K Cast iron	●●	●●	●●		●
N NF metals				●●	●
S Materials with difficult cutting properties			●	●●	●
H Hard materials		●			
O Other				●	●
Insert width s [mm]	2,0–4,0	2,0–4,0	2,0–3,0	3,0	3,0–6,0
a <sub>p</sub> [mm]	0,3–2,8	0,3–2,8	0,2–1,5		
f [mm]	0,10–0,33	0,08–0,38	0,08–0,38	0,04–0,23	0,06–0,28
Page in catalogue	A 383	A 383	A 385	A 376	A 376

QR code

[www.walter-tools.com/woc/](http://www.walter-tools.com/woc/)





UD4

UA4

RD4

CF6

GD3

System	GD				
Machining	Medium feed				High feed
	<b>NEW</b> 	<b>NEW</b> 	<b>NEW</b> 	<b>NEW</b> 	<b>NEW</b> 
Geometry	CF5	GD6	UF4	RF8	CE4
P Steel	●●	●●	●●	●●	●●
M Stainless steel	●●	●●	●●	●●	●
K Cast iron	●	●	●●	●	●●
N NF metals	●●	●	●	●	●
S Materials with difficult cutting properties	●●	●●	●	●●	●
H Hard materials					●
O Other	●				
Insert width s [mm]	2,5–6,0	3,0–6,0	3,0–6,0	3,0–6,0	2,5–6,0
a <sub>p</sub> [mm]			0,3–3,5	0,1–3,0	
f [mm]	0,04–0,28	0,08–0,30	0,10–0,40	0,10–0,55	0,07–0,40
Page in catalogue	A 376	A 376	A 376	A 376	A 376

QR code

[www.walter-tools.com/woc/](http://www.walter-tools.com/woc/)

CF5

GD6

UF4





RF8

CE4





**WALTER SELECT**

●● Primary application ● Other application

## Cutting inserts











System	GD			GX	
Machining	High feed			Low feed	
	<b>NEW</b>	<b>NEW</b>	<b>NEW</b>		
					
Geometry	UD4	UA4	RD4	CK8	CF6
P Steel	●●		●●		●●
M Stainless steel	●		●	●	●●
K Cast iron	●●	●●	●●		
N NF metals				●●	●●
S Materials with difficult cutting properties			●	●	●●
H Hard materials		●			
O Other					●
Insert width s [mm]	3,0–6,0	3,0–6,0	3,0–6,0	2,0–4,0	1,5–3,0
a <sub>p</sub> [mm]	0,4–3,5	0,4–3,5	0,5–3,0		
f [mm]	0,10–0,40	0,10–0,40	0,10–0,70	0,04–0,22	0,03–0,23
Page in catalogue	A 376	A 376	A 376	A 389	A 389











QR code					
www.walter-tools.com/woc/	UD4	UA4	RD4	CK8	CF6

System	GX				
Machining	Low feed				
					
Geometry	GD8	GD3	UF8	VG7	RK8
P Steel	●●	●●	●●	●●	
M Stainless steel	●●	●●	●●	●●	
K Cast iron	●	●	●	●	
N NF metals	●●	●	●●	●●	●●
S Materials with difficult cutting properties	●●	●	●●	●●	
H Hard materials					
O Other		●			●
Insert width s [mm]	1,0–1,4	2,0–6,0	1,6–6,0	2,8	6,0
a <sub>p</sub> [mm]			0,3–3,2	0,2–2,5	0,1–4,0
f [mm]	0,05–0,10	0,04–0,28	0,05–0,35	0,05–0,25	0,10–0,60
Page in catalogue	A 82	A 389	A 395	A 82	A 399

QR code					
www.walter-tools.com/woc/	GD8	GD3	UF8	VG7	RK8

## Cutting inserts

System	GX				
Machining	Low feed		Medium feed		
			<b>NEW</b> 		
Geometry	TM-1	EM-1	CF5	GD6	UD6
P Steel			●●	●●	●
M Stainless steel			●●	●●	●●
K Cast iron			●	●	
N NF metals			●●	●	●
S Materials with difficult cutting properties		●●	●●	●●	
H Hard materials	●●				
O Other			●		
Insert width s [mm]	3,0–6,0	3,0–6,0	2,0–5,0	2,0–6,0	2,0–6,0
a <sub>p</sub> [mm]	0,05–3,0	0,05–3,0			0,3–3,5
f [mm]	0,02–0,15	0,10–0,30	0,03–0,25	0,04–0,30	0,06–0,35
Page in catalogue	A 393	A 393	A 389	A 389	A 396
QR code					
www.walter-tools.com/woc/	TM-1	EM-1	CF5	GD6	UD6

System	GX				
Machining	Medium feed				
					
Geometry	UF4	RF8	RF7	FS-M1	FS-F1
P Steel	●●	●●	●●		
M Stainless steel	●●	●●	●●		
K Cast iron	●●	●	●		
N NF metals	●	●	●	●●	●●
S Materials with difficult cutting properties	●	●●	●●	●	●
H Hard materials					
O Other				●●	●●
Insert width s [mm]	2,0–8,0	2,0–8,0	3,0–5,0	2,0–6,0	2,0–6,0
a <sub>p</sub> [mm]	0,3–4,0	0,1–4,0	0,1–2,5	0,1–3,0	
f [mm]	0,10–0,55	0,05–0,60	0,10–0,53	0,05–0,50	0,04–0,28
Page in catalogue	A 396	A 400	A 400		
QR code					
www.walter-tools.com/woc/	UF4	RF8	RF7	FS-M1	FS-F1

## WALTER SELECT

●● Primary application ● Other application





















## Cutting inserts

System	GX				
Machining	Medium feed	High feed			
Geometry	AF5	CE4	UD4	UA4	RD4
P Steel	●●	●●	●●		●●
M Stainless steel	●●	●	●		●
K Cast iron	●	●●	●●	●●	●●
N NF metals	●	●			
S Materials with difficult cutting properties	●	●			●
H Hard materials		●		●	
O Other					
Insert width s [mm]	5,0	2,0-6,0	2,0-8,0	2,0-6,0	2,0-8,0
a <sub>p</sub> [mm]	0,5		0,3-4,0	0,3-3,5	0,2-4,0
f [mm]	0,15-0,30	0,04-0,40	0,10-0,40	0,08-0,40	0,08-0,80
Page in catalogue	A 82	A 389	A 398	A 398	A 400
QR code					
<a href="http://www.walter-tools.com/woc/">www.walter-tools.com/woc/</a>	AF5	CE4	UD4	UA4	RD4
System	GX	SX			
Machining		Low feed			Medium feed
Geometry	.X.N	CK8	CF6	SK8	CF5
P Steel	●●	●●	●●	●●	●●
M Stainless steel	●●	●	●●		●●
K Cast iron	●●	●●	●●	●●	●
N NF metals	●●	●●	●●	●●	●●
S Materials with difficult cutting properties	●●	●	●●	●	●●
H Hard materials	●●				
O Other	●		●		●
Insert width s [mm]	4,8-10,3	2,0-5,0	2,0-3,0	1,5-4,0	1,5-6,0
a <sub>p</sub> [mm]					
f [mm]		0,04-0,25	0,03-0,23	0,03-0,20	0,03-0,30
Page in catalogue	A 401	A 402	A 402	A 403	A 402
QR code					
<a href="http://www.walter-tools.com/woc/">www.walter-tools.com/woc/</a>	-X-N	CK8	CF6	SK8	CF5

WALTER SELECT

●● Primary application ● Other application







## Cutting inserts

System	SX			UX	WT
Machining	Medium feed		High feed		Low feed
					
Geometry	UF4	SF5	CE4	GD2	CD8
P Steel	●●	●●	●●	●●	●●
M Stainless steel	●●	●●	●		●●
K Cast iron	●●	●	●●	●●	●
N NF metals	●	●●	●		●●
S Materials with difficult cutting properties	●	●●	●		●●
H Hard materials			●		
O Other		●			
Insert width s [mm]	8,0	1,5–5,0	1,5–10,0	12,0–19,0	0,7–2,0
a <sub>p</sub> [mm]	0,9–4,0				
f [mm]	0,18–0,55	0,03–0,25	0,03–0,60	0,20–0,60	0,02–0,14
Page in catalogue	A 403	A 403	A 402	A 404	A 405
QR code					
<a href="http://www.walter-tools.com/woc/">www.walter-tools.com/woc/</a>	UF4	SF5	CE4	GD2	CD8
System	WT				
Machining	Low feed				
					
Geometry	GD8	DG8	UA8	VG8	RA8
P Steel	●●	●●	●●	●●	●●
M Stainless steel	●●	●●	●●	●●	●●
K Cast iron	●	●	●	●	●
N NF metals	●●	●●	●●	●●	●●
S Materials with difficult cutting properties	●●	●●	●●	●●	●●
H Hard materials					
O Other					
Insert width s [mm]	0,5–2,5	3,0	1,0–2,5	3,0	1,25–1,6
a <sub>p</sub> [mm]		0,1–4,0	0,1–3,0	0,1–4,0	0,05–0,8
f [mm]	0,02–0,16	0,02–0,16	0,02–0,16	0,02–0,16	0,02–0,14
Page in catalogue	A 405	A 406	A 405	A 405	A 405
QR code					
<a href="http://www.walter-tools.com/woc/">www.walter-tools.com/woc/</a>	GD8	DG8	UA8	VG8	RA8











WALTER SELECT

●● Primary application ● Other application

















Cutting inserts			
System	WT		
Machining			
	<b>NEW</b> 	<b>NEW</b> 	
Geometry	AG60	ISO	.X..N
<b>P</b> Steel	●●	●●	●●
<b>M</b> Stainless steel	●●	●●	●●
<b>K</b> Cast iron	●	●	●●
<b>N</b> NF metals	●	●●	●●
<b>S</b> Materials with difficult cutting properties	●●	●●	●●
<b>H</b> Hard materials			●●
<b>O</b> Other			●
Insert width s [mm]			3,0
$a_p$ [mm]			
f [mm]			
Page in catalogue	A 408	A 408	A 409
QR code			
<a href="http://www.walter-tools.com/woc/">www.walter-tools.com/woc/</a>	AG60	ISO	-X-N

## Cutting inserts

System	WE..-G	WE..-GR	WE..-GP	WE..-T	
Machining					
	<b>NEW</b> 	<b>NEW</b> 	<b>NEW</b> 	<b>NEW</b> 	<b>NEW</b> 
Geometry	G	GR	GP	T	T-X
P Steel	●●	●●	●●	●●	●●
M Stainless steel	●●	●●	●●	●●	●●
K Cast iron	●	●	●	●	●
N NF metals	●●	●	●	●	●
S Materials with difficult cutting properties	●●	●●	●●	●●	●●
H Hard materials	●	●	●	●	●
O Other	●	●	●	●	●
Insert width s [mm]	0,7–3,18	0,8–3,0	1,0		
a <sub>p</sub> [mm]				0,05–0,3	0,05–0,3
f [mm]	0,01–0,04	0,01–0,04	0,01–0,04	0,02–0,10	0,02–0,10
Page in catalogue	A 410	A 413	A 413	A 416	A 416
QR code					
<a href="http://www.walter-tools.com/woc/">www.walter-tools.com/woc/</a>	G	GR	GP	T	T-X

System	WE..-C	WE..-B	WE..-A	WE..-AR	WE..-AC
Machining					
	<b>NEW</b> 	<b>NEW</b> 	<b>NEW</b> 	<b>NEW</b> 	<b>NEW</b> 
Geometry	C	B	A	AR	AC
P Steel	●●	●●	●●	●●	●●
M Stainless steel	●●	●●	●●	●●	●●
K Cast iron	●	●	●	●	●
N NF metals	●	●	●	●	●
S Materials with difficult cutting properties	●●	●●	●●	●●	●●
H Hard materials	●	●	●	●	●
O Other	●	●	●	●	●
Insert width s [mm]			1,0–3,0	1,5–3,0	1,0–3,0
a <sub>p</sub> [mm]	0,05	0,05			
f [mm]	0,02–0,10	0,02–0,10	0,01–0,04	0,01–0,04	0,01–0,04
Page in catalogue	A 417	A 418	A 415	A 415	
QR code					
<a href="http://www.walter-tools.com/woc/">www.walter-tools.com/woc/</a>	C	B	A	AR	AC

Cutting inserts		
System	WE..-AD	WE..-I
Machining		
		
Geometry	AD	I
<b>P</b> Steel	●●	●●
<b>M</b> Stainless steel	●●	●●
<b>K</b> Cast iron	●	●
<b>N</b> NF metals	●	●
<b>S</b> Materials with difficult cutting properties	●●	●●
<b>H</b> Hard materials	●	
<b>O</b> Other	●	
Insert width s [mm]	1,5–3,0	
$a_p$ [mm]		
f [mm]	0,01–0,04	
Page in catalogue	A 415	A 418
QR code		
<a href="http://www.walter-tools.com/woc/">www.walter-tools.com/woc/</a>	AD	I

## Grooving and parting off – cutting inserts

## MX

## Tiger-tec® Gold

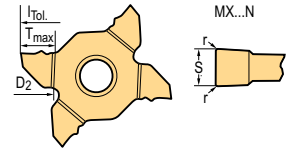

## Cutting inserts

Designation	s mm	r mm	T <sub>max</sub> mm	D <sub>2</sub> mm	f mm	S <sub>Tol</sub> mm	I <sub>Tol</sub> mm	P		M		S	
								HC		HC		HC	
								WSM23G	WSM33G	WSM23G	WSM33G	WSM23G	WSM33G
 MX22-2E050N01-GD8	0,5	0,1	2,5		0,02-0,04	±0,02	±0,03	☺	☺	☺	☺	☺	☺
MX22-2E100N01-GD8	1	0,1	3,5	130	0,03-0,06	±0,02	±0,03	☺	☺	☺	☺	☺	☺
MX22-2E150N01-GD8	1,5	0,1	5	130	0,03-0,09	±0,02	±0,03	☺	☺	☺	☺	☺	☺
MX22-2E170N02-GD8	1,7	0,2	3		0,03-0,10	±0,02	±0,03	☺	☺	☺	☺	☺	☺
MX22-2E200N02-GD8	2	0,2	6	100	0,04-0,10	±0,02	±0,03	☺	☺	☺	☺	☺	☺
MX22-2E224N02-GD8	2,24	0,2	6	100	0,04-0,12	±0,02	±0,03	☺	☺	☺	☺	☺	☺
MX22-2E300N02-GD8	3	0,2	6	100	0,04-0,14	±0,02	±0,03	☺	☺	☺	☺	☺	☺
MX22-2E318N02-GD8	3,18	0,2	6	100	0,04-0,14	±0,02	±0,03	☺	☺	☺	☺	☺	☺
MX22-2E325N02-GD8	3,25	0,2	6	100	0,04-0,15	±0,02	±0,03	☺	☺	☺	☺	☺	☺

 I<sub>Tol</sub> = Repeat accuracy when changing indexable inserts within one insert batch

 Radius tolerance r<sub>Tol</sub> = ±0.05 mm

Ordering example for the grade WSM23G: MX22-2E050N01-GD8 WSM23G

HC = Coated carbide

# Grooving and parting off – cutting inserts

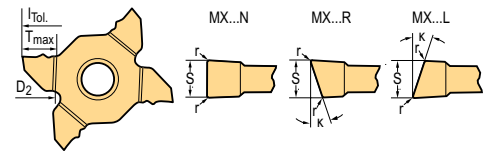

## MX

### Tiger-tec® Gold



A2

### Cutting inserts

Designation	s mm	r mm	κ	T <sub>max</sub> mm	D <sub>2</sub> mm	f mm	S <sub>Tol</sub> mm	h <sub>Tol</sub> mm	P			M			S		
									HC			HC			HC		
									WSM13G	WSM23G	WSM33G	WSM13G	WSM23G	WSM33G	WSM13G	WSM23G	WSM33G
 MX22-2E080N01-CF5	0,8	0,1		1,6	130	0,02–0,05	±0,02	±0,03	☺	☺	☺	☺	☺	☺	☺	☺	☺
MX22-2E100N01-CF5	1	0,1		3,5	130	0,03–0,07	±0,02	±0,03	☺	☺	☺	☺	☺	☺	☺	☺	☺
MX22-2E104N01-CF5	1,04	0,1		2		0,03–0,07	±0,02	±0,03	☺	☺	☺	☺	☺	☺	☺	☺	☺
MX22-2E120N01-CF5	1,2	0,1		2		0,03–0,08	±0,02	±0,03	☺	☺	☺	☺	☺	☺	☺	☺	☺
MX22-2E140N01-CF5	1,4	0,1		2		0,03–0,09	±0,02	±0,03	☺	☺	☺	☺	☺	☺	☺	☺	☺
MX22-2E147N01-CF5	1,47	0,1		2,5		0,03–0,09	±0,02	±0,03	☺	☺	☺	☺	☺	☺	☺	☺	☺
MX22-2E150N01-CF5	1,5	0,1		5	130	0,03–0,10	±0,02	±0,03	☺	☺	☺	☺	☺	☺	☺	☺	☺
MX22-2E157N02-CF5	1,57	0,2		3		0,04–0,12	±0,02	±0,03	☺	☺	☺	☺	☺	☺	☺	☺	☺
MX22-2E170N02-CF5	1,7	0,2		3		0,04–0,12	±0,02	±0,03	☺	☺	☺	☺	☺	☺	☺	☺	☺
MX22-2E185N02-CF5	1,85	0,2		3		0,04–0,12	±0,02	±0,03	☺	☺	☺	☺	☺	☺	☺	☺	☺
MX22-2E196N02-CF5	1,96	0,2		3		0,04–0,12	±0,02	±0,03	☺	☺	☺	☺	☺	☺	☺	☺	☺
MX22-2E200N02-CF5	2	0,2		6	100	0,04–0,14	±0,02	±0,03	☺	☺	☺	☺	☺	☺	☺	☺	☺
MX22-2E224N02-CF5	2,24	0,2		6	100	0,04–0,16	±0,02	±0,03	☺	☺	☺	☺	☺	☺	☺	☺	☺
MX22-2E239N02-CF5	2,39	0,2		6	100	0,04–0,16	±0,02	±0,03	☺	☺	☺	☺	☺	☺	☺	☺	☺
MX22-2E250N02-CF5	2,5	0,2		6	100	0,04–0,16	±0,02	±0,03	☺	☺	☺	☺	☺	☺	☺	☺	☺
MX22-2E275N02-CF5	2,75	0,2		6	100	0,04–0,16	±0,02	±0,03	☺	☺	☺	☺	☺	☺	☺	☺	☺
MX22-2E300N02-CF5	3	0,2		6	100	0,04–0,16	±0,02	±0,03	☺	☺	☺	☺	☺	☺	☺	☺	☺
MX22-2E318N02-CF5	3,18	0,2		6	100	0,04–0,16	±0,02	±0,03	☺	☺	☺	☺	☺	☺	☺	☺	☺
MX22-2E325N02-CF5	3,25	0,2		6	100	0,04–0,16	±0,02	±0,03	☺	☺	☺	☺	☺	☺	☺	☺	☺
MX22-4E400N02-CF5	4	0,2		6	100	0,10–0,20	±0,02	±0,03	☺	☺	☺	☺	☺	☺	☺	☺	☺
MX22-4E400N04-CF5	4	0,4		6	100	0,10–0,20	±0,02	±0,03	☺	☺	☺	☺	☺	☺	☺	☺	☺
MX22-4E425N02-CF5	4,25	0,2		6	100	0,10–0,20	±0,02	±0,03	☺	☺	☺	☺	☺	☺	☺	☺	☺
MX22-4E480N06-CF5	4,8	0,6		6	100	0,10–0,25	±0,02	±0,03	☺	☺	☺	☺	☺	☺	☺	☺	☺
MX22-4E500N02-CF5	5	0,2		6	100	0,10–0,25	±0,02	±0,03	☺	☺	☺	☺	☺	☺	☺	☺	☺
MX22-4E500N04-CF5	5	0,4		6	100	0,10–0,25	±0,02	±0,03	☺	☺	☺	☺	☺	☺	☺	☺	☺
 MX22-2E100R10-CF5	1	0,05	10	3,5	130	0,02–0,04	±0,02	±0,03	☺	☺	☺	☺	☺	☺	☺	☺	☺
MX22-2E150R10-CF5	1,5	0,05	10	5	130	0,03–0,06	±0,02	±0,03	☺	☺	☺	☺	☺	☺	☺	☺	☺
MX22-2E200R6-CF5	2	0,1	6	6	100	0,04–0,12	±0,02	±0,03	☺	☺	☺	☺	☺	☺	☺	☺	☺
 MX22-2E080L5-CF5	0,8	0,05	5	1,6	130	0,02–0,04	±0,02	±0,03	☺	☺	☺	☺	☺	☺	☺	☺	☺
MX22-2E100L10-CF5	1	0,05	10	3,5	130	0,02–0,04	±0,02	±0,03	☺	☺	☺	☺	☺	☺	☺	☺	☺
MX22-2E150L10-CF5	1,5	0,05	10	5	130	0,03–0,06	±0,02	±0,03	☺	☺	☺	☺	☺	☺	☺	☺	☺
MX22-2E200L6-CF5	2	0,1	6	6	100	0,04–0,12	±0,02	±0,03	☺	☺	☺	☺	☺	☺	☺	☺	☺



h<sub>Tol</sub> = Repeat accuracy when changing indexable inserts within one insert batch  
 Radius tolerance r<sub>Tol</sub> = ±0.05 mm  
 Ordering example for the grade WSM23G: MX22-2E080N01-CF5 WSM23G

HC = Coated carbide

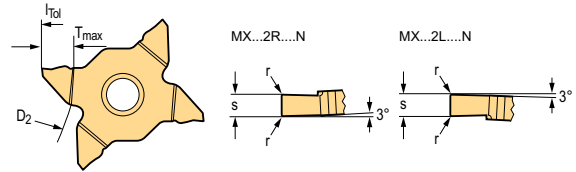
## Grooving and parting off 3° – cutting inserts

**MX**
**Tiger-tec® Gold**

### Cutting inserts

Designation	s mm	r mm	T <sub>max</sub> mm	D <sub>2</sub> mm	f mm	S <sub>Tol</sub> mm	I <sub>Tol</sub> mm	Material		
								P WSM23G	M WSM23G	S WSM23G
 MX22-2R150N01-GD8 MX22-2R200N02-GD8 MX22-2R300N02-GD8	1,5	0,1	5	130	0,03–0,06	±0,02	±0,03	☺	☺	☺
	2	0,2	5	100	0,04–0,10	±0,02	±0,03	☺	☺	☺
	3	0,2	5	100	0,05–0,14	±0,02	±0,03	☺	☺	☺
 MX22-2L150N01-GD8 MX22-2L200N02-GD8 MX22-2L300N02-GD8	1,5	0,1	5	130	0,03–0,06	±0,02	±0,03	☺	☺	☺
	2	0,2	5	100	0,04–0,10	±0,02	±0,03	☺	☺	☺
	3	0,2	5	100	0,04–0,14	±0,02	±0,03	☺	☺	☺

$I_{Tol}$  = Repeat accuracy when changing indexable inserts within one insert batch  
 Radius tolerance  $r_{Tol} = \pm 0.05$  mm  
 When using the cutting insert MX22-2R... tool G3051...R must be used  
 When using cutting insert MX22-2L... tool G3051...L must be used  
 Ordering example for the grade WSM23G: MX22-2R150N01-GD8 WSM23G

HC = Coated carbide

## Grooving and recessing 3° – Cutting inserts

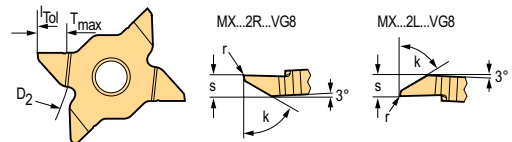
**MX**
**Tiger-tec® Gold**

### Cutting inserts

Designation	s mm	r mm	κ	T <sub>max</sub> mm	D <sub>2</sub> mm	f mm	S <sub>Tol</sub> mm	I <sub>Tol</sub> mm	Material		
									P WSM23G	M WSM23G	S WSM23G
 MX22-2R280R01-VG8	2,8	0,05	60	5,5	100	0,05–0,12	±0,02	±0,03	☺	☺	☺
	MX22-2L280L01-VG8	2,8	0,05	60	5,5	100	0,05–0,12	±0,02	±0,03	☺	☺

$I_{Tol}$  = Repeat accuracy when changing indexable inserts within one insert batch  
 Radius tolerance  $r_{Tol} = \pm 0.05$  mm  
 Ordering example for the grade WSM23G: MX22-2R280R01-VG8 WSM23G

HC = Coated carbide

**WALTER SELECT**

Optimum indexable insert for → Good = ☺ → Average = ☹ → Poor = ☹ machining conditions

# Grooving and copy turning – cutting inserts

MX

**Tiger-tec® Gold**

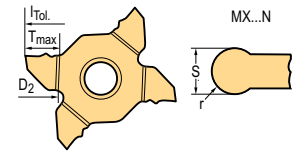

## Cutting inserts

Designation	s mm	r mm	T <sub>max</sub> mm	D <sub>2</sub> mm	f mm	S <sub>Tol</sub> mm	l <sub>Tol</sub> mm	P		M		S	
								HC		HC		HC	
								WSM23G	WSM13G	WSM23G	WSM13G	WSM23G	WSM13G
 MX22-2E157N08-RF5	1,57	0,79	3	130	0,04-0,12	±0,02	±0,03	☺	☺	☺	☺	☺	☺
MX22-2E200N10-RF5	2	1	6	100	0,04-0,14	±0,02	±0,03	☺	☺	☺	☺	☺	☺
MX22-2E239N12-RF5	2,39	1,2	6	100	0,04-0,18	±0,02	±0,03	☺	☺	☺	☺	☺	☺
MX22-2E300N15-RF5	3	1,5	6	100	0,04-0,20	±0,02	±0,03	☺	☺	☺	☺	☺	☺
MX22-2E318N16-RF5	3,18	1,59	6	100	0,04-0,20	±0,02	±0,03	☺	☺	☺	☺	☺	☺
MX22-4E400N20-RF5	4	2	6	100	0,06-0,22	±0,02	±0,03	☺	☺	☺	☺	☺	☺
MX22-4E500N25-RF5	5	2,5	6	100	0,06-0,25	±0,02	±0,03	☺	☺	☺	☺	☺	☺

l<sub>Tol</sub> = Repeat accuracy when changing indexable inserts within one insert batch  
 Radius tolerance r<sub>Tol</sub> = ±0.05 mm  
 Ordering example for the grade WSM23G: MX22-2E157N08-RF5 WSM23G

HC = Coated carbide

# External thread – Full profile – Cutting inserts

MX

**Tiger-tec® Gold**

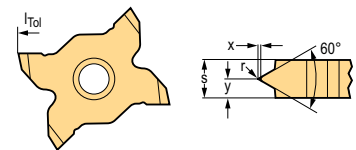

## Indexable inserts

Designation	P mm	s mm	r mm	X mm	Y mm	P		M		S	
						HC		HC		HC	
						WSM23G	WSM13G	WSM23G	WSM13G	WSM23G	WSM13G
 MX22-2E-EN1.00ISO	1	3,35	0,13	0,13	1,68	☺	☺	☺	☺	☺	☺
MX22-2E-EN1.50ISO	1,5	3,35	0,19	0,19	1,68	☺	☺	☺	☺	☺	☺
MX22-2E-EN2.00ISO	2	3,35	0,25	0,25	1,68	☺	☺	☺	☺	☺	☺

l<sub>Tol</sub> = Repeat accuracy when changing indexable inserts within one insert batch  
 Radius tolerance r<sub>Tol</sub> = ±0.05 mm  
 Ordering example for the grade WSM23G: MX22-2E-EN1.00ISO WSM23G

HC = Coated carbide

**WALTER SELECT** Optimum indexable insert for → Good = ☺ → Average = ☹ → Poor = ☹ machining conditions

☺ ☹ ☹ / ★ = New addition to the product range

Single-, double- and multi-edged cutting inserts A 379

## External thread – 60° partial profile – cutting inserts

MX

Tiger-tec® Gold

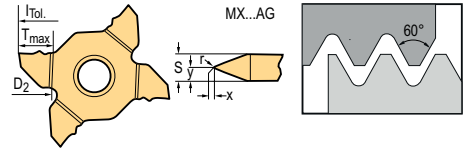

## Indexable inserts

Designation	P mm	Pitch (P) in	s mm	r mm	X mm	Y mm	P		M		S	
							WSM23G	WSM33G	WSM23G	WSM33G	WSM23G	WSM33G
MX22-2E-EN-A60	0,5-1,5	48-16	3,35	0,05	0,05	1,68	☺	☺	☺	☺	☺	☺
MX22-4E-EN-AG60	0,5-3	48-8	5,65	0,08	0,08	2,83	☹	☹	☹	☹	☹	☹

$l_{Tol}$  = Repeat accuracy when changing indexable inserts within one insert batch  
 Radius tolerance  $r_{Tol} = \pm 0.05$  mm  
 Ordering example for the grade WSM23G: MX22-2E-EN-A60 WSM23G

HC = Coated carbide

## Semi-finished blanks for special shapes

MX

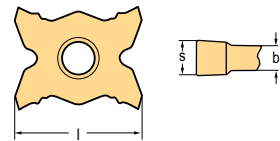

## Cutting inserts

Designation	s mm	l mm	P		M		S	
			WVG30	HF	WVG30	HF	WVG30	HF
MX22-2E335N	3,35	23,2	☺	☺	☺	☺	☺	☺
MX22-4E565N	5,65	23,2	☹	☹	☹	☹	☹	☹

Grade WVG30 has the ISO application ranges P20, M20, S20  
 Ordering example for the grade WVG30: MX22-2E335N WVG30

HF = Uncoated fine-grained carbide



## Grooving and parting off – cutting inserts

### DX

### Tiger-tec® Gold

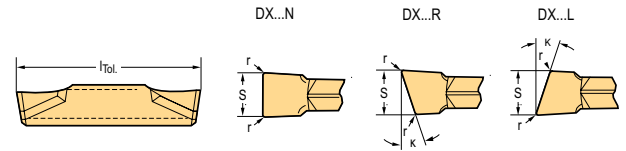

A2

### Cutting inserts

Designation	s mm	r mm	κ	l mm	f mm	S <sub>Tol</sub> mm	l <sub>Tol</sub> mm	P				M				K	N	S			
								HC				HC				HC	HF	HC			
								WSM13G	WKP23G	WSM23G	WSM33G	WSM43G	WSM13G	WSM23G	WSM33G	WSM43G	WKP23G	WN13	WSM13G	WSM23G	WSM33G
DX18-1E150N01-CK8	1.5	0.15		18	0.04–0.10	±0.02	±0.15								☺						
DX18-2E200N02-CK8	2	0.2		18	0.04–0.12	±0.02	±0.15								☺						
DX18-3E300N02-CK8	3	0.2		18	0.08–0.20	±0.02	±0.15								☺						
DX18-4E400N02-CK8	4	0.2		18	0.10–0.22	±0.02	±0.15								☺						
DX18-2E200R7-CK8	2	0	7	18	0.04–0.10	±0.02	±0.15								☺						
DX18-2E200L7-CK8	2	0	7	18	0.04–0.10	±0.02	±0.15								☺						
DX18-1E100N01-CF6	1	0.1		18	0.03–0.10	±0.05	±0.15			☺										☺	
DX18-1E150N01-CF6	1.5	0.15		18	0.03–0.12	±0.05	±0.15			☺	☺									☺	☺
DX18-2E200N02-CF6	2	0.2		18	0.03–0.14	±0.05	±0.15			☺	☺									☺	☺
DX18-2E250N02-CF6	2.5	0.2		18	0.03–0.18	±0.05	±0.15			☺	☺									☺	☺
DX18-3E300N02-CF6	3	0.2		18	0.04–0.23	±0.05	±0.15			☺	☺									☺	☺
DX18-1E150R10-CF6	1.5	0	10	18	0.03–0.12	±0.05	±0.15			☺										☺	
DX18-2E200R6-CF6	2	0.2	6	18	0.03–0.14	±0.05	±0.15			☺	☺									☺	☺
DX18-2E250R6-CF6	2.5	0.2	6	18	0.03–0.18	±0.05	±0.15			☺	☺									☺	☺
DX18-3E300R6-CF6	3	0.2	6	18	0.04–0.23	±0.05	±0.15			☺	☺									☺	☺
DX18-2E200R15-CF6	2	0	15	18.3	0.03–0.14	±0.05	±0.15			☺										☺	☺
DX18-3E300R15-CF6	3	0	15	18.8	0.04–0.23	±0.05	±0.15			☺										☺	☺
DX18-1E150L10-CF6	1.5	0	10	18	0.03–0.12	±0.05	±0.15			☺										☺	
DX18-2E200L6-CF6	2	0.2	6	18	0.03–0.14	±0.05	±0.15			☺	☺									☺	☺
DX18-2E250L6-CF6	2.5	0.2	6	18	0.03–0.18	±0.05	±0.15			☺	☺									☺	☺
DX18-3E300L6-CF6	3	0.2	6	18	0.04–0.23	±0.05	±0.15			☺	☺									☺	☺
DX18-2E200L15-CF6	2	0	15	18.3	0.03–0.14	±0.05	±0.15			☺										☺	☺
DX18-1E100N01-CF5	1	0.1		18	0.03–0.10	±0.05	±0.15			☺										☺	
DX18-1E150N01-CF5	1.5	0.15		18	0.03–0.12	±0.05	±0.15			☺	☺									☺	☺
DX18-2E200N00-CF5	2	0		18	0.03–0.12	±0.05	±0.15			☺	☺									☺	☺
DX18-2E200N02-CF5	2	0.2		18	0.04–0.14	±0.05	±0.15	☺	☺	☺	☺									☺	☺
DX18-2E250N02-CF5	2.5	0.2		18	0.05–0.18	±0.05	±0.15			☺	☺									☺	☺
DX18-3E300N02-CF5	3	0.2		18	0.08–0.23	±0.05	±0.15	☺	☺	☺	☺									☺	☺
DX18-1E150R10-CF5	1.5	0	10	18	0.03–0.06	±0.05	±0.15			☺										☺	
DX18-2E200R6-CF5	2	0.2	6	18	0.03–0.12	±0.05	±0.15			☺	☺									☺	☺
DX18-2E200R7-CF5	2	0	7	18	0.03–0.12	±0.05	±0.15			☺										☺	
DX18-2E200R15-CF5	2	0	15	18	0.03–0.12	±0.05	±0.15			☺										☺	
DX18-2E250R6-CF5	2.5	0.2	6	18	0.03–0.15	±0.05	±0.15			☺										☺	
DX18-3E300R6-CF5	3	0.2	6	18	0.04–0.19	±0.05	±0.15			☺										☺	
DX18-3E300R7-CF5	3	0	7	18.8	0.04–0.16	±0.05	±0.15			☺										☺	
DX18-3E300R15-CF5	3	0	15	18.8	0.04–0.16	±0.05	±0.15			☺										☺	

l<sub>Tol</sub> = Repeat accuracy when changing indexable inserts within one insert batch  
 Radius tolerance r<sub>Tol</sub> = ±0.05 mm  
 Ordering example for the grade WN13: DX18-1E150N01-CK8 WN13

HC = Coated carbide  
 HF = Uncoated fine-grained carbide

**WALTER SELECT** Optimum indexable insert for → Good = ☺ → Average = ☹ → Poor = ☹☹ machining conditions

☺ ☹ ☹☹ / \* = New addition to the product range

## Grooving and parting off – cutting inserts

A2

DX

Tiger-tec® Gold

DX...N

DX...R

DX...L

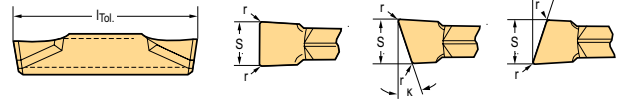

## Cutting inserts

Designation	s mm	r mm	k	l mm	f mm	S <sub>Tol</sub> mm	l <sub>Tol</sub> mm	P				M				K	N	S						
								HC				HC				HC	HF	HC						
								WSM13G	WKP23G	WSM23G	WSM33G	WSM43G	WSM13G	WSM23G	WSM33G	WSM43G	WKP23G	WN13	WSM13G	WSM23G	WSM33G	WSM43G		
DX18-1E150L10-CF5	1,5	0	10	18	0,03-0,06	±0,05	±0,15				☺	☺										☺	☺	
DX18-2E200L6-CF5	2	0,2	6	18	0,03-0,12	±0,05	±0,15				☺	☺	☺									☺	☺	☺
DX18-2E200L7-CF5	2	0	7	18	0,03-0,12	±0,05	±0,15			☺	☺	☺										☺	☺	☺
DX18-2E200L15-CF5	2	0	15	18	0,03-0,12	±0,05	±0,15				☺	☺										☺	☺	☺
DX18-2E250L6-CF5	2,5	0,2	6	18	0,03-0,15	±0,05	±0,15				☺	☺										☺	☺	☺
DX18-3E300L6-CF5	3	0,2	6	18	0,04-0,19	±0,05	±0,15				☺	☺										☺	☺	☺
DX18-3E300L7-CF5	3	0	7	18,8	0,04-0,16	±0,05	±0,15				☺	☺										☺	☺	☺
DX18-3E300L15-CF5	3	0	15	18,8	0,04-0,16	±0,05	±0,15				☺	☺										☺	☺	☺
DX18-3F300N02-CF5	3	0,2		18	0,08-0,23	±0,05	±0,15				☺	☺										☺	☺	☺
DX18-1E120N01-CE4	1,2	0,15		18	0,04-0,13	±0,05	±0,15				☺	☺										☺	☺	☺
DX18-1E150N01-CE4	1,5	0,15		18	0,03-0,12	±0,05	±0,15				☺	☺	☺									☺	☺	☺
DX18-2E200N02-CE4	2	0,2		18	0,06-0,17	±0,05	±0,15	☺	☺	☺	☺	☺		☺	☺	☺	☺				☺	☺	☺	☺
DX18-2E250N02-CE4	2,5	0,2		18	0,07-0,21	±0,05	±0,15	☺	☺	☺	☺	☺		☺	☺	☺	☺				☺	☺	☺	☺
DX18-3E300N02-CE4	3	0,2		18	0,09-0,33	±0,05	±0,15	☺	☺	☺	☺	☺		☺	☺	☺	☺				☺	☺	☺	☺
DX18-2E200R6-CE4	2	0,2	6	18	0,04-0,12	±0,05	±0,15				☺	☺										☺	☺	☺
DX18-2E250R6-CE4	2,5	0,2	6	18	0,05-0,15	±0,05	±0,15				☺	☺										☺	☺	☺
DX18-3E300R6-CE4	3	0,2	6	18	0,09-0,27	±0,05	±0,15				☺	☺										☺	☺	☺
DX18-2E200L6-CE4	2	0,2	6	18	0,04-0,12	±0,05	±0,15				☺	☺										☺	☺	☺
DX18-2E250L6-CE4	2,5	0,2	6	18	0,05-0,15	±0,05	±0,15				☺	☺										☺	☺	☺
DX18-3E300L6-CE4	3	0,2	6	18	0,09-0,27	±0,05	±0,15				☺	☺										☺	☺	☺
DX18-3F300N02-CE4	3	0,2		18	0,09-0,33	±0,05	±0,15				☺	☺										☺	☺	☺
DX18-2E200N02-GD6	2	0,2		18	0,04-0,14	±0,05	±0,15				☺	☺										☺	☺	☺
DX18-2E250N02-GD6	2,5	0,2		18	0,06-0,20	±0,05	±0,15				☺	☺										☺	☺	☺
DX18-3E300N03-GD6	3	0,3		18	0,08-0,21	±0,05	±0,15				☺	☺										☺	☺	☺
DX18-4E400N04-GD6	4	0,4		18,5	0,10-0,25	±0,05	±0,15				☺	☺										☺	☺	☺
DX18-2E200N02-GD3	2	0,2		18	0,04-0,15	±0,05	±0,15	☺	☺	☺	☺	☺										☺	☺	☺
DX18-2E250N02-GD3	2,5	0,2		18	0,04-0,17	±0,05	±0,15	☺	☺	☺	☺	☺										☺	☺	☺
DX18-3E300N03-GD3	3	0,3		18	0,06-0,21	±0,05	±0,15	☺	☺	☺	☺	☺										☺	☺	☺
DX18-4E400N04-GD3	4	0,4		18,5	0,10-0,23	±0,05	±0,15	☺	☺	☺	☺	☺										☺	☺	☺

 l<sub>Tol</sub> = Repeat accuracy when changing indexable inserts within one insert batch

 Radius tolerance r<sub>Tol</sub> = ±0.05 mm

Ordering example for the grade WN13: DX18-1E150N01-CK8 WN13

HC = Coated carbide

HF = Uncoated fine-grained carbide



## Grooving and parting off – cutting inserts

DX

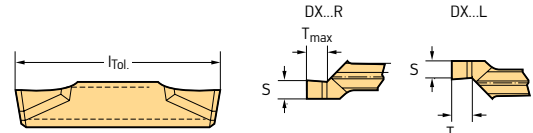
**Tiger-tec® Gold**



### Cutting inserts

Designation	s mm	r mm	l mm	f mm	S <sub>Tol</sub> mm	l <sub>Tol</sub> mm	P	M	S
							HC	HC	HC
 DX18-2E100R00-GD8	1	0	18	0,05–0,10	±0,05	±0,15	WSM23G	WSM23G	WSM23G
DX18-2E120R00-GD8	1,2	0	18	0,05–0,10	±0,05	±0,15	☺	☺	☺
DX18-2E140R00-GD8	1,4	0,2	18	0,05–0,10	±0,05	±0,15	☺	☺	☺
 DX18-2E100L00-GD8	1	0	18	0,05–0,10	±0,05	±0,15	☺	☺	☺
DX18-2E120L00-GD8	1,2	0	18	0,05–0,10	±0,05	±0,15	☺	☺	☺
DX18-2E140L00-GD8	1,4	0	18	0,05–0,10	±0,05	±0,15	☺	☺	☺

Ordering example for the grade WSM23G: DX18-2E100R00-GD8 WSM23G

HC = Coated carbide

## Grooving and recessing – cutting inserts

DX

**Tiger-tec® Gold**

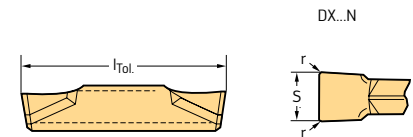

### Cutting inserts

Designation	s mm	r mm	l mm	f mm	a <sub>p</sub> mm	S <sub>Tol</sub> mm	l <sub>Tol</sub> mm	P				M				K			S			H	
								WSM13G	WSM13G	WKP23G	WSM23G	WKP33G	WSM33G	WSM43G	WSM13G	WSM23G	WSM33G	WSM43G	WKP13G	WKP23G	WKP33G	WSM13G	WSM23G
 DX18-1E160N01-UF8	1,6	0,1	18	0,05–0,17	0,3–1,0	±0,02	±0,15			☺				☺					☺				
DX18-1E170N01-UF8	1,7	0,1	18	0,05–0,17	0,3–1,0	±0,02	±0,15			☺				☺					☺				
DX18-1E185N01-UF8	1,85	0,1	18	0,05–0,22	0,3–1,0	±0,02	±0,15			☺				☺					☺				
DX18-1E196N01-UF8	1,96	0,1	18	0,05–0,22	0,3–1,2	±0,02	±0,15			☺				☺					☺				
DX18-2E200N02-UF8	2	0,2	18	0,05–0,22	0,3–1,2	±0,02	±0,15			☺				☺					☺				
DX18-2E225N01-UF8	2,25	0,1	18	0,05–0,22	0,3–1,3	±0,02	±0,15			☺				☺					☺				
DX18-2E275N01-UF8	2,75	0,1	18	0,06–0,22	0,3–1,3	±0,02	±0,15			☺				☺					☺				
DX18-3E300N02-UF8	3	0,2	18	0,07–0,24	0,4–1,5	±0,02	±0,15			☺				☺					☺				
DX18-3E318N02-UF8	3,18	0,2	18	0,07–0,24	0,4–1,5	±0,02	±0,15			☺				☺					☺				
DX18-3E325N01-UF8	3,25	0,1	18	0,07–0,24	0,4–1,6	±0,02	±0,15			☺				☺					☺				
DX18-4E400N04-UF8	4	0,4	18	0,09–0,30	0,5–2,2	±0,02	±0,15			☺				☺					☺				
DX18-4E425N02-UF8	4,25	0,2	18	0,09–0,30	0,5–2,2	±0,02	±0,15			☺				☺					☺				

l<sub>Tol</sub> = Repeat accuracy when changing indexable inserts within one insert batch

Radius tolerance r<sub>Tol</sub> = ±0,05 mm

Ordering example for the grade WSM23G: DX18-1E160N01-UF8 WSM23G

HC = Coated carbide

**WALTER SELECT** Optimum indexable insert for → Good = ☺ → Average = ☹ → Poor = ☹ machining conditions

☺ ☹ ☹ / \* = New addition to the product range

Single-, double- and multi-edged cutting inserts A 383

## Grooving and recessing – cutting inserts

A2

DX

Tiger-tec® Gold

DX..N

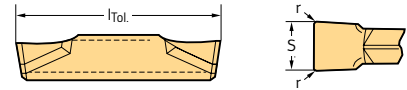

## Cutting inserts

Designation	s mm	r mm	l mm	f mm	a <sub>p</sub> mm	S <sub>Tol</sub> mm	l <sub>Tol</sub> mm	P					M				K			S			H												
								WKP13G	WSM13G	WKP23G	WSM23G	WKP33G	WSM33G	WSM43G	WSM13G	WSM23G	WSM33G	WSM43G	WKP13G	WKP23G	WKP33G	WSM13G	WSM23G	WSM33G	WSM43G	WKP13G									
DX18-2E200N02-UF7	2	0.2	18	0.05-0.22	0.3-1.2	±0.05	±0.15																												
DX18-3E300N02-UF7	3	0.2	18	0.07-0.24	0.4-1.5	±0.05	±0.15																												
DX18-4E400N02-UF7	4	0.2	18	0.09-0.30	0.3-2.2	±0.05	±0.15																												
DX18-2E200N02-UF4	2	0.2	18	0.10-0.18	0.3-1.2	±0.05	±0.15																												
DX18-2E239N02-UF4	2.39	0.2	18	0.10-0.15	0.3-0.0	±0.05	±0.15																												
DX18-2E250N02-UF4	2.5	0.2	18	0.10-0.21	0.3-1.3	±0.05	±0.15																												
DX18-3E300N03-UF4	3	0.3	18	0.10-0.23	0.4-2.0	±0.05	±0.15																												
DX18-4E400N02-UF4	4	0.2	18.5	0.10-0.33	0.3-2.8	±0.05	±0.15																												
DX18-4E400N04-UF4	4	0.4	18.5	0.10-0.33	0.5-2.8	±0.05	±0.15																												
DX18-4E400N08-UF4	4	0.8	18.5	0.10-0.33	0.9-2.8	±0.05	±0.15																												
DX18-4F400N04-UF4	4	0.4	18.5	0.10-0.33	0.5-2.8	±0.05	±0.15																												
DX18-2E200N02-UD4	2	0.2	18	0.10-0.18	0.3-1.2	±0.05	±0.15																												
DX18-3E300N03-UD4	3	0.3	18	0.10-0.23	0.4-2.0	±0.05	±0.15																												
DX18-4E400N04-UD4	4	0.4	18.5	0.10-0.33	0.5-2.8	±0.05	±0.15																												
DX18-4E400N08-UD4	4	0.8	18.5	0.10-0.33	0.9-2.8	±0.05	±0.15																												
DX18-2E200N02-UA4	2	0.2	18	0.08-0.18	0.3-1.2	±0.05	±0.15																												
DX18-3E300N03-UA4	3	0.3	18	0.10-0.25	0.4-2.0	±0.05	±0.15																												
DX18-4E400N04-UA4	4	0.4	18	0.08-0.18	0.3-1.2	±0.05	±0.15																												
DX18-4E400N08-UA4	4	0.8	18.5	0.10-0.38	0.9-2.8	±0.05	±0.15																												

l<sub>Tol</sub> = Repeat accuracy when changing indexable inserts within one insert batch  
 Radius tolerance r<sub>Tol</sub> = ±0.05 mm  
 Ordering example for the grade WSM23G: DX18-1E160N01-UF8 WSM23G

HC = Coated carbide

# Grooving and copy turning – cutting inserts

DX

**Tiger-tec® Gold**

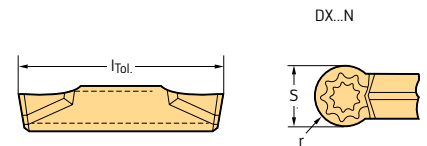

A2

## Cutting inserts

Designation	s mm	r mm	l mm	f mm	a <sub>p</sub> mm	S <sub>Tol</sub> mm	l <sub>Tol</sub> mm	P				M			K		S	
								HC				HC			HC		HC	
								WSM13G	WKP23G	WSM23G	WSM33G	WSM13G	WSM23G	WSM33G	WKP23G	WSM13G	WSM23G	WSM33G
DX18-3E300N15-RF8	3	1.5	18	0,08–0,26	0,1–1,0	±0,02	±0,15	☺	☺	☺	☺	☺	☺			☺	☺	
DX18-2E200N10-RF7	2	1	18,3	0,08–0,26	0,1–1,0	±0,05	±0,15	☺	☺	☺	☺					☺	☺	
DX18-3E300N15-RF7	3	1,5	18,3	0,10–0,33	0,1–1,5	±0,05	±0,15	☺	☺	☺	☺					☺	☺	
DX18-4E400N20-RF7	4	2	18,5	0,12–0,48	0,1–2,0	±0,05	±0,15		☺		☺					☺	☺	
DX18-2E200N10-RD4	2	1	18,3	0,08–0,28	0,2–1,0	±0,05	±0,15	☺	☺	☺	☺			☺	☺	☺	☺	
DX18-2E239N12-RD4	2,39	1,2	18,3	0,08–0,25	0,2–1,0	±0,05	±0,15	☺	☺	☺	☺			☺	☺	☺	☺	
DX18-3E300N15-RD4	3	1,5	18,3	0,10–0,38	0,5–1,5	±0,05	±0,15	☺	☺	☺	☺			☺	☺	☺	☺	

l<sub>Tol</sub> = Repeat accuracy when changing indexable inserts within one insert batch  
 Radius tolerance r<sub>Tol</sub> = ±0.05 mm  
 Ordering example for the grade WSM13G: DX18-3E300N15-RF8 WSM13G

HC = Coated carbide

## Grooving and parting off – cutting inserts

### GD

### Tiger-tec® Gold



GD...N

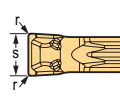

GD...R

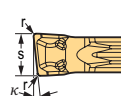

GD...L

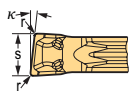

#### Cutting inserts

Designation	s mm	r mm	k	l mm	f mm	S <sub>Tol</sub> mm	l <sub>Tol</sub> mm	P		M				K	S			
								WSM13G	WKP23G	WSM23G	WSM33G	WSM43G	WSM13G	WSM23G	WSM33G	WSM43G	WKP23G	WSM13G
GD26-3E300N02-CF6	3	0.2		26,5	0,04-0,23	±0,05	±0,15											
GD26-3E300R6-CF6	3	0.2	6	26,5	0,04-0,20	±0,05	±0,15											
GD26-3E300L6-CF6	3	0.2	6	26,5	0,04-0,20	±0,05	±0,15											
GD26-3F300N02-CF6	3	0.2		26,5	0,04-0,23	±0,05	±0,15											
GD26-2E250N02-CF5	2,5	0,2		26,5	0,05-0,15	±0,05	±0,15											
GD26-3E300N02-CF5	3	0,2		26,5	0,08-0,20	±0,05	±0,15	☺	☺	☺	☺	☺	☺	☺	☺	☺	☺	
GD26-4E400N02-CF5	4	0,2		26,5	0,10-0,22	±0,05	±0,15	☺	☺	☺	☺	☺	☺	☺	☺	☺	☺	
GD26-5E500N03-CF5	5	0,3		26,5	0,10-0,25	±0,05	±0,15	☺	☺	☺	☺	☺	☺	☺	☺	☺	☺	
GD26-6E600N03-CF5	6	0,3		26,5	0,10-0,28	±0,05	±0,15		☺									
GD26-3E300R6-CF5	3	0,2	6	26,5	0,04-0,16	±0,05	±0,15											
GD26-3E300L6-CF5	3	0,2	6	26,5	0,04-0,16	±0,05	±0,15											
GD26-5F500N03-CF5	5	0,3		26,2	0,10-0,25	±0,05	±0,15											
GD26-3F300N02-CF5	3	0,2		26,5	0,08-0,20	±0,05	±0,15											
GD26-4F400N02-CF5	4	0,2		26,5	0,10-0,22	±0,05	±0,15											
GD26-2E250N02-CE4	2,5	0,2		26,5	0,07-0,18	±0,05	±0,15											
GD26-3E300N02-CE4	3	0,2		26,5	0,09-0,30	±0,05	±0,15	☺	☺	☺	☺	☺	☺	☺	☺	☺	☺	
GD26-4E400N03-CE4	4	0,3		26,5	0,10-0,32	±0,05	±0,15	☺	☺	☺	☺	☺	☺	☺	☺	☺	☺	
GD26-5E500N03-CE4	5	0,3		26,5	0,12-0,35	±0,05	±0,15	☺	☺	☺	☺	☺	☺	☺	☺	☺	☺	
GD26-6E600N03-CE4	6	0,3		26,5	0,12-0,40	±0,05	±0,15	☺	☺	☺	☺	☺	☺	☺	☺	☺	☺	
GD26-3E300R6-CE4	3	0,2	6	26,5	0,09-0,24	±0,05	±0,15	☺	☺	☺	☺	☺	☺	☺	☺	☺	☺	
GD26-4E400R6-CE4	4	0,2	6	26,5	0,10-0,26	±0,05	±0,15											
GD26-3E300L6-CE4	3	0,2	6	26,5	0,09-0,24	±0,05	±0,15	☺	☺	☺	☺	☺	☺	☺	☺	☺	☺	
GD26-4E400L6-CE4	4	0,2	6	26,5	0,10-0,26	±0,05	±0,15											
GD26-3F300N02-CE4	3	0,2		26,5	0,09-0,24	±0,05	±0,15											
GD26-4F400N03-CE4	4	0,3		26,5	0,10-0,32	±0,05	±0,15											

 l<sub>Tol</sub> = Repeat accuracy when changing indexable inserts within one insert batch

HC = Coated carbide

 Radius tolerance r<sub>Tol</sub> = ±0.05 mm

Ordering example for the grade WSM33G: GD26-3E300N02-CF6 WSM33G

**WALTER SELECT**

Optimum indexable insert for → Good = ☺ → Average = ☹ → Poor = ☹☹☹ machining conditions



## Grooving and parting off – cutting inserts

GD

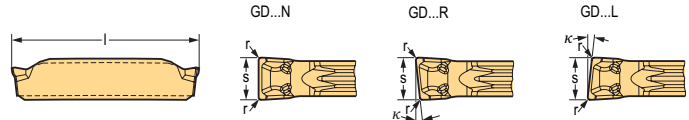
**Tiger-tec® Gold**



### Cutting inserts

Designation	s mm	r mm	κ	l mm	f mm	S <sub>Tol</sub> mm	l <sub>Tol</sub> mm	P				M				K		S				
								HC				HC				HC		HC				
								WSM13G	WKP23G	WSM23G	WSM33G	WSM43G	WSM13G	WSM23G	WSM33G	WSM43G	WKP23G	WSM13G	WSM23G	WSM33G	WSM43G	
 GD26-3E300N03-GD6	3	0,3		26,5	0,08–0,18	±0,05	±0,15			☺	☺			☺	☺					☺	☺	
GD26-4E400N04-GD6	4	0,4		26,5	0,10–0,22	±0,05	±0,15			☺	☺			☺	☺					☺	☺	
GD26-5E500N04-GD6	5	0,4		26,5	0,12–0,24	±0,05	±0,15			☺	☺			☺	☺					☺	☺	
GD26-6E600N05-GD6	6	0,5		26,5	0,14–0,30	±0,05	±0,15			☺	☺			☺	☺					☺	☺	
 GD26-3E300N03-GD3	3	0,3		26,5	0,06–0,18	±0,05	±0,15	☺	☺	☺	☺			☺	☺					☺	☺	☺
GD26-4E400N04-GD3	4	0,4		26,5	0,10–0,20	±0,05	±0,15	☺	☺	☺	☺			☺	☺					☺	☺	☺
GD26-5E500N04-GD3	5	0,4		26,5	0,12–0,25	±0,05	±0,15	☺	☺	☺	☺			☺	☺					☺	☺	☺
GD26-6E600N05-GD3	6	0,5		26,5	0,14–0,28	±0,05	±0,15	☺	☺	☺	☺			☺	☺					☺	☺	☺

l<sub>Tol</sub> = Repeat accuracy when changing indexable inserts within one insert batch  
 Radius tolerance r<sub>Tol</sub> = ±0.05 mm  
 Ordering example for the grade WSM33G: GD26-3E300N02-CF6 WSM33G  
 HC = Coated carbide

## Grooving and recessing – cutting inserts

GD

**Tiger-tec® Gold**

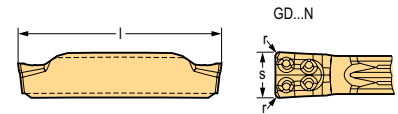

### Cutting inserts

Designation	s mm	r mm	l mm	f mm	a <sub>p</sub> mm	S <sub>Tol</sub> mm	l <sub>Tol</sub> mm	P				M			K			S		H				
								HC				HC			HC			HC		HC				
								WKP13G	WKP23G	WSM23G	WKP33G	WSM33G	WSM43G	WSM23G	WSM33G	WSM43G	WKP13G	WKP23G	WKP33G	WSM23G	WSM33G	WSM43G	WKP13G	
 GD26-3E300N02-UF4	3	0,2	26,5	0,10–0,20	0,3–2,0	±0,05	±0,15				☺	☺												
GD26-3E300N03-UF4	3	0,3	26,5	0,10–0,20	0,4–2,0	±0,05	±0,15			☺	☺	☺	☺								☺	☺	☺	
GD26-3E318N03-UF4	3,18	0,3	26,5	0,10–0,20	0,4–2,0	±0,05	±0,15			☺	☺	☺	☺								☺	☺	☺	
GD26-4E400N02-UF4	4	0,2	26,5	0,10–0,30	0,3–2,8	±0,05	±0,15				☺	☺									☺	☺	☺	
GD26-4E400N04-UF4	4	0,4	26,5	0,10–0,30	0,5–2,8	±0,05	±0,15			☺	☺	☺	☺								☺	☺	☺	
GD26-4E400N08-UF4	4	0,8	26,5	0,10–0,30	0,5–2,8	±0,05	±0,15			☺	☺	☺	☺								☺	☺	☺	
GD26-5E500N04-UF4	5	0,4	26,5	0,12–0,35	0,5–3,0	±0,05	±0,15			☺	☺	☺	☺								☺	☺	☺	
GD26-5E500N08-UF4	5	0,8	26,5	0,12–0,35	0,5–3,0	±0,05	±0,15			☺	☺	☺	☺								☺	☺	☺	
GD26-6E600N05-UF4	6	0,5	26,5	0,14–0,40	0,6–3,5	±0,05	±0,15			☺	☺	☺	☺								☺	☺	☺	
GD26-6E600N08-UF4	6	0,8	26,5	0,14–0,40	0,6–3,5	±0,05	±0,15			☺	☺	☺	☺								☺	☺	☺	

l<sub>Tol</sub> = Repeat accuracy when changing indexable inserts within one insert batch  
 Radius tolerance r<sub>Tol</sub> = ±0.05 mm  
 Ordering example for the grade WSM33G: GD26-3E300N02-UF4 WSM33G  
 HC = Coated carbide



## Grooving and recessing – cutting inserts

GD

Tiger-tec® Gold

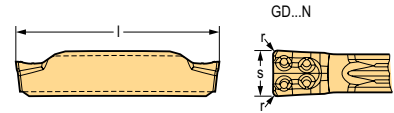

## Cutting inserts

Designation	s mm	r mm	l mm	f mm	ap mm	STol mm	lTol mm	P					M			K			S			H						
								HC					HC			HC			HC			HC						
								WKP13G	WKP23G	WSM23G	WKP33G	WSM33G	WSM43G	WKP13G	WKP23G	WKP33G	WSM23G	WSM33G	WSM43G	WKP13G	WKP23G	WKP33G	WSM23G	WSM33G	WSM43G	WKP13G		
GD26-3E300N03-UD4	3	0,3	26,5	0,10–0,20	0,4–2,0	±0,05	±0,15	☺	☺	☺	☺	☺		☺	☺	☺	☺	☺	☺	☺	☺	☺	☺	☺	☺			
GD26-3E318N03-UD4	3,18	0,3	26,5	0,10–0,20	0,4–2,0	±0,05	±0,15	☺	☺																			
GD26-4E400N04-UD4	4	0,4	26,5	0,10–0,30	0,5–2,8	±0,05	±0,15	☺	☺	☺	☺	☺		☺	☺	☺	☺	☺	☺	☺	☺	☺	☺	☺	☺			
GD26-4E400N08-UD4	4	0,8	26,5	0,10–0,30	0,5–2,8	±0,05	±0,15	☺	☺	☺	☺	☺		☺	☺	☺	☺	☺	☺	☺	☺	☺	☺	☺	☺			
GD26-5E500N04-UD4	5	0,4	26,5	0,12–0,35	0,5–3,0	±0,05	±0,15	☺	☺	☺	☺	☺		☺	☺	☺	☺	☺	☺	☺	☺	☺	☺	☺	☺			
GD26-5E500N08-UD4	5	0,8	26,5	0,12–0,35	0,5–3,0	±0,05	±0,15	☺	☺	☺	☺	☺		☺	☺	☺	☺	☺	☺	☺	☺	☺	☺	☺	☺			
GD26-6E600N05-UD4	6	0,5	26,5	0,14–0,40	0,6–3,5	±0,05	±0,15	☺	☺	☺	☺	☺		☺	☺	☺	☺	☺	☺	☺	☺	☺	☺	☺	☺			
GD26-6E600N08-UD4	6	0,8	26,5	0,14–0,40	0,6–3,5	±0,05	±0,15	☺	☺	☺	☺	☺		☺	☺	☺	☺	☺	☺	☺	☺	☺	☺	☺	☺			
GD26-3E300N03-UA4	3	0,3	26,5	0,10–0,22	0,4–2,0	±0,05	±0,15	☺			☺									☺	☺	☺					☺	
GD26-4E400N04-UA4	4	0,4	26,5	0,10–0,35	0,5–2,8	±0,05	±0,15	☺			☺									☺	☺	☺					☺	
GD26-5E500N04-UA4	5	0,4	26,5	0,12–0,35	0,5–3,0	±0,05	±0,15	☺			☺									☺	☺	☺					☺	
GD26-6E600N05-UA4	6	0,5	26,5	0,14–0,40	0,6–3,5	±0,05	±0,15	☺			☺									☺	☺	☺					☺	

 lTol = Repeat accuracy when changing indexable inserts within one insert batch  
 Radius tolerance rTol = ±0.05 mm  
 Ordering example for the grade WSM33G: GD26-3E300N02-UF4 WSM33G

HC = Coated carbide

## Grooving and copy turning – cutting inserts

GD

Tiger-tec® Gold

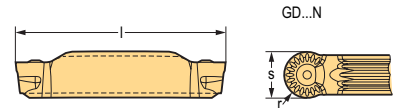

## Cutting inserts

Designation	s mm	r mm	l mm	f mm	ap mm	STol mm	lTol mm	P				M			K	S		
								HC				HC			HC	HC		
								WSM13G	WKP23G	WSM23G	WSM33G	WSM13G	WSM23G	WSM33G	WKP23G	WSM13G	WSM23G	WSM33G
GD26-3E300N15-RF8	3	1,5	26,5	0,10–0,30	0,1–1,5	±0,05	±0,15	☺	☺	☺	☺	☺	☺	☺	☺	☺	☺	☺
GD26-4E400N20-RF8	4	2	26,5	0,12–0,45	0,1–2,0	±0,05	±0,15	☺	☺	☺	☺	☺	☺	☺	☺	☺	☺	☺
GD26-5E500N25-RF8	5	2,5	26,5	0,15–0,50	0,1–2,5	±0,05	±0,15	☺	☺	☺	☺	☺	☺	☺	☺	☺	☺	☺
GD26-6E600N30-RF8	6	3	26,5	0,15–0,55	0,1–3,0	±0,05	±0,15	☺	☺	☺	☺	☺	☺	☺	☺	☺	☺	☺
GD26-3E300N15-RD4	3	1,5	26,5	0,10–0,35	0,5–1,5	±0,05	±0,15	☺	☺	☺	☺				☺	☺		☺
GD26-3E318N16-RD4	3,18	1,6	26,5	0,10–0,35	0,5–1,5	±0,05	±0,15	☺	☺	☺	☺				☺	☺		☺
GD26-4E400N20-RD4	4	2	26,5	0,15–0,50	0,5–2,0	±0,05	±0,15	☺	☺	☺	☺				☺	☺		☺
GD26-5E500N25-RD4	5	2,5	26,5	0,17–0,60	0,5–2,5	±0,05	±0,15	☺	☺	☺	☺				☺	☺		☺
GD26-6E600N30-RD4	6	3	26,5	0,17–0,70	0,5–3,0	±0,05	±0,15	☺	☺	☺	☺				☺	☺		☺

 lTol = Repeat accuracy when changing indexable inserts within one insert batch  
 Radius tolerance rTol = ±0.05 mm  
 Ordering example for the grade WSM13G: GD26-3E300N15-RF8 WSM13G

HC = Coated carbide



# Grooving and parting off – cutting inserts

GX

Tiger-tec® Gold

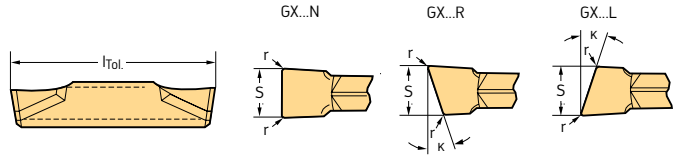

## Cutting inserts

Designation	s mm	r mm	k	l mm	f mm	S <sub>Tol</sub> mm	l <sub>Tol</sub> mm	P					M					K		N		S				
								HC					HC					HC	HW	HC						
								WKP23S	WSM23S	WSM33G	WSM43S	WSM43G	WSM43S	WSM23S	WSM33G	WSM33S	WSM43G	WSM43S	WKP23S	WK1	WSM23S	WSM33G	WSM33S	WSM43G	WSM43S	
GX16-1E200N02-CK8	2	0.2		16,6	0,04-0,12	±0,02	±0,03													☺						
GX16-2E300N02-CK8	3	0.2		16,6	0,08-0,20	±0,02	±0,03													☺						
GX24-2E300N02-CK8	3	0.2		24,6	0,08-0,20	±0,02	±0,03													☺						
GX24-3E400N02-CK8	4	0.2		24,6	0,10-0,22	±0,02	±0,03													☺						
GX16-0E150N01-CF6	1,5	0,15		16,6	0,03-0,12	±0,02	±0,05			☹				☹											☹	
GX16-1E200N02-CF6	2	0,2		16,6	0,03-0,14	±0,05	±0,15			☹	☹			☹	☹										☹	☹
GX16-1E250N02-CF6	2,5	0,2		16,6	0,03-0,18	±0,05	±0,15			☹				☹											☹	
GX16-2E300N02-CF6	3	0,2		16,6	0,04-0,23	±0,05	±0,15			☹	☹			☹	☹										☹	☹
GX24-1E200N02-CF6	2	0,2		24	0,03-0,14	±0,05	±0,15			☹				☹											☹	
GX24-2E300N02-CF6	3	0,2		24,6	0,04-0,23	±0,05	±0,15			☹	☹			☹	☹										☹	☹
GX16-1E200R15-CF6	2	0	15	16,2	0,03-0,14	±0,05	±0,15			☹				☹											☹	
GX16-2E300R15-CF6	3	0	15	16,2	0,04-0,23	±0,05	±0,15			☹				☹											☹	
GX16-0E150R10-CF6	1,5	0,15	10	16,6	0,03-0,12	±0,05	±0,05			☹				☹											☹	
GX16-1E200R6-CF6	2	0,2	6	16,6	0,03-0,14	±0,05	±0,15			☹				☹											☹	
GX16-1E250R6-CF6	2,5	0,2	6	16,6	0,03-0,18	±0,05	±0,15			☹				☹											☹	
GX16-2E300R6-CF6	3	0,2	6	16,6	0,04-0,23	±0,05	±0,15			☹				☹											☹	
GX24-2E300R6-CF6	3	0,2	6	24,6	0,04-0,23	±0,05	±0,15			☹				☹											☹	
GX24-2E300L6-CF6	3	0,2	6	24,6	0,04-0,23	±0,05	±0,15			☹				☹											☹	

l<sub>Tol</sub> = Repeat accuracy when changing indexable inserts within one insert batch  
 Radius tolerance r<sub>Tol</sub> = ±0.05 mm  
 Parting off with diameters up to 32 mm is possible with GX16 inserts (l = 16.6 mm)  
 Ordering example for the grade WK1: GX16-1E200N02-CK8 WK1

HC = Coated carbide  
 HW = Uncoated carbide

**WALTER SELECT** Optimum indexable insert for → Good = ☺ → Average = ☹ → Poor = ☹ machining conditions

☺ ☹ ☹ / ★ = New addition to the product range

Single-, double- and multi-edged cutting inserts A 389

## Grooving and parting off – cutting inserts

## GX

## Tiger-tec® Gold

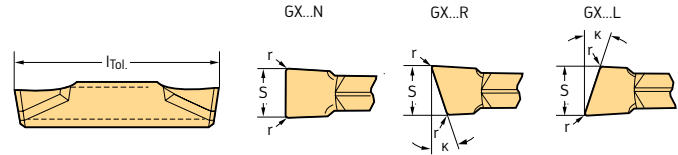

## Cutting inserts

Designation	s mm	r mm	k	l mm	f mm	S <sub>Tol</sub> mm	l <sub>Tol</sub> mm	P					M					K		N		S				
								HC					HC					HC		HW		HC				
								WKP23S	WSM23S	WSM33G	WSM33S	WSM43G	WSM43S	WSM23S	WSM33G	WSM33S	WSM43G	WSM43S	WKP23S	WK1	WSM23S	WSM33G	WSM33S	WSM43G	WSM43S	
GX16-1E200N02-CF5	2	0.2		16,6	0,04–0,12	±0,05	±0,15	☺	☺	☺	☺	☺	☺	☺	☺	☺	☺	☺	☺	☺	☺	☺	☺	☺	☺	
GX16-1E250N02-CF5	2,5	0,2		16,6	0,05–0,15	±0,05	±0,15	☺	☺	☺	☺	☺	☺	☺	☺	☺	☺	☺	☺	☺	☺	☺	☺	☺	☺	
GX16-2E300N02-CF5	3	0,2		16,6	0,08–0,20	±0,05	±0,15	☺	☺	☺	☺	☺	☺	☺	☺	☺	☺	☺	☺	☺	☺	☺	☺	☺	☺	
GX24-1E200N02-CF5	2	0,2		24	0,04–0,12	±0,05	±0,15	☺	☺	☺	☺	☺	☺	☺	☺	☺	☺	☺	☺	☺	☺	☺	☺	☺	☺	
GX24-1E250N02-CF5	2,5	0,2		24	0,05–0,15	±0,05	±0,15	☺	☺	☺	☺	☺	☺	☺	☺	☺	☺	☺	☺	☺	☺	☺	☺	☺	☺	
GX24-2E300N02-CF5	3	0,2		24	0,08–0,20	±0,05	±0,15	☺	☺	☺	☺	☺	☺	☺	☺	☺	☺	☺	☺	☺	☺	☺	☺	☺	☺	
GX24-3E400N02-CF5	4	0,2		24	0,10–0,22	±0,05	±0,15	☺	☺	☺	☺	☺	☺	☺	☺	☺	☺	☺	☺	☺	☺	☺	☺	☺	☺	
GX24-3E500N03-CF5	5	0,3		24	0,10–0,25	±0,05	±0,15	☺	☺	☺	☺	☺	☺	☺	☺	☺	☺	☺	☺	☺	☺	☺	☺	☺	☺	
GX24-2E300N00-CF5	3	0		24,6	0,04–0,16	±0,02	±0,05	☺	☺	☺	☺	☺	☺	☺	☺	☺	☺	☺	☺	☺	☺	☺	☺	☺	☺	
GX34-2E300N03-CF5	3	0,3		34	0,08–0,20	±0,05	±0,15	☺	☺	☺	☺	☺	☺	☺	☺	☺	☺	☺	☺	☺	☺	☺	☺	☺	☺	
GX34-3E400N04-CF5	4	0,4		34	0,10–0,22	±0,05	±0,15	☺	☺	☺	☺	☺	☺	☺	☺	☺	☺	☺	☺	☺	☺	☺	☺	☺	☺	
GX16-1E200R7-CF5	2	0	7	16,4	0,03–0,10	±0,05	±0,15	☺	☺	☺	☺	☺	☺	☺	☺	☺	☺	☺	☺	☺	☺	☺	☺	☺	☺	
GX16-1E200R15-CF5	2	0	15	16,4	0,03–0,10	±0,05	±0,15	☺	☺	☺	☺	☺	☺	☺	☺	☺	☺	☺	☺	☺	☺	☺	☺	☺	☺	
GX16-1E200R6-CF5	2	0,2	6	16,6	0,03–0,10	±0,05	±0,15	☺	☺	☺	☺	☺	☺	☺	☺	☺	☺	☺	☺	☺	☺	☺	☺	☺	☺	
GX16-1E250R6-CF5	2,5	0,2	6	16,6	0,03–0,12	±0,05	±0,15	☺	☺	☺	☺	☺	☺	☺	☺	☺	☺	☺	☺	☺	☺	☺	☺	☺	☺	
GX16-2E300R6-CF5	3	0,2	6	16,6	0,04–0,16	±0,05	±0,15	☺	☺	☺	☺	☺	☺	☺	☺	☺	☺	☺	☺	☺	☺	☺	☺	☺	☺	
GX16-2E300R15-CF5	3	0	15	16,6	0,04–0,13	±0,05	±0,15	☺	☺	☺	☺	☺	☺	☺	☺	☺	☺	☺	☺	☺	☺	☺	☺	☺	☺	
GX24-2E300R6-CF5	3	0,2	6	24,6	0,04–0,16	±0,05	±0,15	☺	☺	☺	☺	☺	☺	☺	☺	☺	☺	☺	☺	☺	☺	☺	☺	☺	☺	
GX24-3E400R6-CF5	4	0,2	6	24,6	0,10–0,18	±0,05	±0,15	☺	☺	☺	☺	☺	☺	☺	☺	☺	☺	☺	☺	☺	☺	☺	☺	☺	☺	
GX34-2E300R6-CF5	3	0,3	6	34	0,04–0,16	±0,05	±0,15	☺	☺	☺	☺	☺	☺	☺	☺	☺	☺	☺	☺	☺	☺	☺	☺	☺	☺	
GX24-2E300L6-CF5	3	0,2	6	24,6	0,04–0,16	±0,05	±0,15	☺	☺	☺	☺	☺	☺	☺	☺	☺	☺	☺	☺	☺	☺	☺	☺	☺	☺	
GX24-3E400L6-CF5	4	0,2	6	24,6	0,10–0,18	±0,05	±0,15	☺	☺	☺	☺	☺	☺	☺	☺	☺	☺	☺	☺	☺	☺	☺	☺	☺	☺	
GX34-2E300L6-CF5	3	0,3	6	34	0,04–0,16	±0,05	±0,15	☺	☺	☺	☺	☺	☺	☺	☺	☺	☺	☺	☺	☺	☺	☺	☺	☺	☺	

l<sub>Tol</sub> = Repeat accuracy when changing indexable inserts within one insert batch  
 Radius tolerance r<sub>Tol</sub> = ±0.05 mm  
 Parting off with diameters up to 32 mm is possible with GX16 inserts (l = 16.6 mm)  
 Ordering example for the grade WK1: GX16-1E200N02-CK8 WK1

HC = Coated carbide  
 HW = Uncoated carbide

# Grooving and parting off – cutting inserts

## GX

### Tiger-tec® Gold

GX...N

GX...R

GX...L

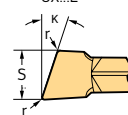
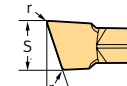
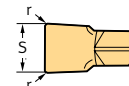
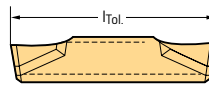

A2

## Cutting inserts

Designation	s mm	r mm	k	l mm	f mm	S <sub>Tol</sub> mm	l <sub>Tol</sub> mm	P					M					K		N		S													
								HC					HC					HC	HW	HC															
								WKP23S	WSM23S	WSM33G	WSM33S	WSM43G	WSM43S	WSM23S	WSM33G	WSM33S	WSM43G	WSM43S	WKP23S	WK1	WSM23S	WSM33G	WSM33S	WSM43G	WSM43S	WSM23S	WSM33G	WSM33S	WSM43G	WSM43S					
	GX24-2F300N02-CF5	3	0.2		23.7	0.08-0.20	±0.05	±0.15				☺	☺			☺	☺																		
	GX24-3F400N02-CF5	4	0.2		23.7	0.10-0.22	±0.05	±0.15				☺	☺			☺	☺																		
	GX24-3F500N03-CF5	5	0.3		23.7	0.10-0.25	±0.05	±0.15				☺	☺			☺	☺																		
	GX16-1E200N02-CE4	2	0.2		16.6	0.06-0.15	±0.05	±0.15		☺	☺	☺	☺			☺	☺																		
	GX16-1E250N02-CE4	2.5	0.2		16.6	0.07-0.18	±0.05	±0.15				☺	☺			☺	☺																		
	GX16-2E300N02-CE4	3	0.2		16.6	0.09-0.30	±0.05	±0.15		☺	☺	☺	☺			☺	☺																		
	GX24-1E200N02-CE4	2	0.2		24	0.06-0.15	±0.05	±0.15		☺	☺	☺	☺			☺	☺																		
	GX24-1E250N02-CE4	2.5	0.2		24	0.07-0.18	±0.05	±0.15	☺			☺	☺			☺	☺																		
	GX24-2E300N02-CE4	3	0.2		24	0.09-0.30	±0.05	±0.15	☺	☺		☺	☺			☺	☺																		
	GX24-3E400N03-CE4	4	0.3		24	0.10-0.32	±0.05	±0.15	☺	☺		☺	☺			☺	☺																		
	GX24-3E500N03-CE4	5	0.3		24	0.12-0.35	±0.05	±0.15	☺			☺	☺			☺	☺																		
	GX24-4E600N03-CE4	6	0.3		24	0.12-0.40	±0.05	±0.15	☺			☺	☺			☺	☺																		
	GX34-2E300N03-CE4	3	0.3		34	0.09-0.30	±0.05	±0.15	☺		☺	☺	☺			☺	☺																		
		GX16-1E200R6-CE4	2	0.2	6	16.6	0.04-0.10	±0.05	±0.15				☺	☺			☺	☺																	
GX16-1E250R6-CE4		2.5	0.2	6	16.6	0.05-0.12	±0.05	±0.15				☺	☺			☺	☺																		
GX16-2E300R6-CE4		3	0.2	6	16.6	0.09-0.24	±0.05	±0.15				☺	☺			☺	☺																		
GX24-2E300R6-CE4		3	0.2	6	24.6	0.09-0.24	±0.05	±0.15	☺			☺	☺			☺	☺																		
GX24-3E400R6-CE4		4	0.2	6	24.6	0.10-0.26	±0.05	±0.15				☺	☺			☺	☺																		
	GX16-2E300L6-CE4	3	0.2	6	16.6	0.09-0.24	±0.05	±0.15				☺	☺			☺	☺																		
	GX24-2E300L6-CE4	3	0.2	6	24.6	0.09-0.24	±0.05	±0.15	☺			☺	☺			☺	☺																		
	GX24-3E400L6-CE4	4	0.2	6	24.6	0.10-0.26	±0.05	±0.15				☺	☺			☺	☺																		
	GX34-2E300L6-CE4	3	0.3	6	34	0.09-0.24	±0.05	±0.15			☺	☺	☺			☺	☺																		

l<sub>Tol</sub> = Repeat accuracy when changing indexable inserts within one insert batch  
 Radius tolerance r<sub>Tol</sub> = ±0.05 mm  
 Parting off with diameters up to 32 mm is possible with GX16 inserts (l = 16.6 mm)  
 Ordering example for the grade WK1: GX16-1E200N02-CK8 WK1

HC = Coated carbide  
 HW = Uncoated carbide

**WALTER SELECT** Optimum indexable insert for → Good = ☺ → Average = ☹ → Poor = ☹☹ machining conditions

## Grooving and parting off – cutting inserts

GX

Tiger-tec® Gold

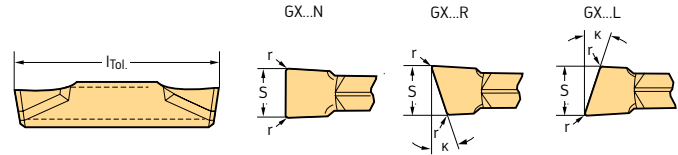

## Cutting inserts

Designation	s mm	r mm	k	l mm	f mm	S <sub>Tol</sub> mm	l <sub>Tol</sub> mm	P					M					K		N		S				
								HC					HC					HC	HW	HC						
								WKP23S	WSM23S	WSM33G	WSM33S	WSM43G	WSM43S	WSM23S	WSM33G	WSM33S	WSM43G	WSM43S	WKP23S	WK1	WSM23S	WSM33G	WSM33S	WSM43G	WSM43S	
GX24-2F300N02-CE4	3	0.2		24	0.09–0.30	±0.05	±0.15				☺	☺	☺			☺	☺	☺						☺	☺	
GX24-3F400N03-CE4	4	0.3		24	0.10–0.32	±0.05	±0.15				☺	☺	☺			☺	☺	☺						☺	☺	
GX09-1E200N02-GD3	2	0.2		9	0.04–0.12	±0.02	±0.02	☺		☺	☺				☺	☺			☺				☺	☺		
GX09-1E250N02-GD3	2.5	0.2		9	0.04–0.14	±0.02	±0.02			☺					☺								☺			
GX09-2E300N03-GD3	3	0.3		9	0.06–0.18	±0.02	±0.02	☺		☺	☺				☺	☺			☺				☺	☺		
GX16-1E200N02-GD3	2	0.2		16	0.04–0.12	±0.02	±0.02	☺		☺					☺				☺				☺			
GX16-1E250N02-GD3	2.5	0.2		16	0.04–0.14	±0.02	±0.02	☺											☺					☺		
GX16-2E300N03-GD3	3	0.3		16	0.06–0.18	±0.02	±0.02	☺		☺					☺	☺			☺				☺	☺		
GX16-3E400N04-GD3	4	0.4		16	0.10–0.20	±0.02	±0.02	☺		☺					☺	☺			☺				☺	☺		
GX24-2E300N03-GD3	3	0.3		24	0.06–0.18	±0.05	±0.15	☺		☺	☺				☺	☺			☺				☺	☺	☺	
GX24-3E400N04-GD3	4	0.4		24	0.10–0.20	±0.05	±0.15	☺		☺	☺				☺	☺			☺				☺	☺	☺	
GX24-3E500N04-GD3	5	0.4		24	0.12–0.25	±0.05	±0.15	☺		☺					☺	☺			☺				☺	☺		
GX24-4E600N05-GD3	6	0.5		24	0.14–0.28	±0.05	±0.15	☺		☺					☺	☺			☺				☺	☺		
GX16-1E200N02-GD6	2	0.2		16	0.04–0.12	±0.05	±0.15	☺		☺					☺	☺			☺				☺	☺		
GX16-2E300N03-GD6	3	0.3		16	0.08–0.18	±0.05	±0.15			☺					☺				☺				☺			
GX16-3E400N04-GD6	4	0.4		16	0.10–0.22	±0.05	±0.15	☺							☺				☺				☺			
GX24-2E300N03-GD6	3	0.3		24	0.08–0.18	±0.05	±0.15	☺		☺					☺	☺			☺				☺	☺		
GX24-3E400N04-GD6	4	0.4		24	0.10–0.22	±0.05	±0.15	☺		☺					☺	☺			☺				☺	☺		
GX24-3E500N04-GD6	5	0.4		24	0.12–0.24	±0.05	±0.15	☺		☺					☺	☺			☺				☺	☺		
GX24-4E600N05-GD6	6	0.5		24	0.14–0.30	±0.05	±0.15	☺		☺					☺	☺			☺				☺	☺		
GX34-2E300N03-GD6	3	0.3		34	0.08–0.20	±0.05	±0.15			☺					☺								☺			
GX34-3E400N04-GD6	4	0.4		34	0.10–0.22	±0.05	±0.15			☺					☺								☺			

l<sub>Tol</sub> = Repeat accuracy when changing indexable inserts within one insert batch  
 Radius tolerance r<sub>Tol</sub> = ±0.05 mm  
 Parting off with diameters up to 32 mm is possible with GX16 inserts (l = 16.6 mm)  
 Ordering example for the grade WK1: GX16-1E200N02-CK8 WK1

HC = Coated carbide  
 HW = Uncoated carbide

# Grooving and parting off – cutting inserts

GX

Tiger-tec® Gold

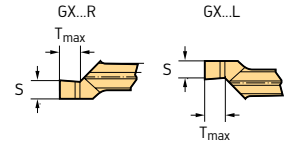
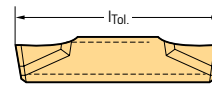

## Cutting inserts

Designation	s mm	r mm	T <sub>max</sub> mm	l mm	f mm	S <sub>Tol</sub> mm	h <sub>Tol</sub> mm	P		M		S	
								HC	WSM23G	HC	WSM23G	HC	WSM23G
GX09-1E100R00-GD8	1	0	1,14	9	0,05-0,10	±0,02	±0,02	☺	☺	☺	☺	☺	☺
GX09-1E120R00-GD8	1,2	0	1,34	9	0,05-0,10	±0,02	±0,02	☺	☺	☺	☺	☺	☺
GX09-1E140R00-GD8	1,4	0	1,53	9	0,05-0,10	±0,02	±0,02	☺	☺	☺	☺	☺	☺
GX16-2E100R00-GD8	1	0	1,14	16	0,05-0,10	±0,02	±0,02	☺	☺	☺	☺	☺	☺
GX16-2E120R00-GD8	1,2	0	1,34	16	0,05-0,10	±0,02	±0,02	☺	☺	☺	☺	☺	☺
GX16-2E140R00-GD8	1,4	0	1,53	16	0,05-0,10	±0,02	±0,02	☺	☺	☺	☺	☺	☺
GX09-1E100L00-GD8	1	0	1,14	9	0,05-0,10	±0,02	±0,02	☺	☺	☺	☺	☺	☺
GX09-1E120L00-GD8	1,2	0	1,34	9	0,05-0,10	±0,02	±0,02	☺	☺	☺	☺	☺	☺
GX09-1E140L00-GD8	1,4	0	1,53	9	0,05-0,10	±0,02	±0,02	☺	☺	☺	☺	☺	☺
GX16-2E100L00-GD8	1	0	1,14	16	0,05-0,10	±0,02	±0,02	☺	☺	☺	☺	☺	☺
GX16-2E120L00-GD8	1,2	0	1,34	16	0,05-0,10	±0,02	±0,02	☺	☺	☺	☺	☺	☺
GX16-2E140L00-GD8	1,4	0	1,53	16	0,05-0,10	±0,02	±0,02	☺	☺	☺	☺	☺	☺

l<sub>Tol</sub> = Repeat accuracy when changing indexable inserts within one insert batch  
 Radius tolerance r<sub>Tol</sub> = ±0.05 mm  
 Ordering example for the grade WSM23G: GX09-1E100R00-GD8 WSM23G

HC = Coated carbide

# CBN – grooving and parting off

GX

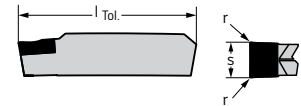

## Cutting inserts

Designation	s mm	r mm	l mm	f mm	S <sub>Tol</sub> mm	h <sub>Tol</sub> mm	S		H	
							WBS10	WBH20	BH	BL
GX24-2F300N02EM-1	3	0,2	24	0,10-0,15	±0,02	±0,03	☺	☺	☺	☺
GX24-3F400N02EM-1	4	0,2	24	0,10-0,20	±0,02	±0,03	☺	☺	☺	☺
GX24-3F500N04EM-1	5	0,4	24	0,10-0,25	±0,02	±0,03	☺	☺	☺	☺
GX24-4F600N04EM-1	6	0,4	24	0,10-0,30	±0,02	±0,03	☺	☺	☺	☺
GX24-2F300N02TM-1	3	0,2	24	0,02-0,10	±0,02	±0,03	☺	☺	☺	☺
GX24-3F400N02TM-1	4	0,2	24	0,02-0,12	±0,02	±0,03	☺	☺	☺	☺
GX24-3F500N04TM-1	5	0,4	24	0,02-0,14	±0,02	±0,03	☺	☺	☺	☺
GX24-4F600N04TM-1	6	0,4	24	0,02-0,15	±0,02	±0,03	☺	☺	☺	☺

l<sub>Tol</sub> = Repeat accuracy when changing indexable inserts within one insert batch  
 Radius tolerance r<sub>Tol</sub> = ±0.05 mm  
 Ordering example for the grade WBS10: GX24-2F300N02EM-1 WBS10

BH = CBN with high CBN content  
 BL = CBN with low CBN content

**WALTER SELECT** Optimum indexable insert for → Good = ☺ → Average = ☹ → Poor = ☹ machining conditions

☺ ☹ ☹ / ★ = New addition to the product range

Single-, double- and multi-edged cutting inserts A 393

# PCD – grooving and parting off

## GX

A2

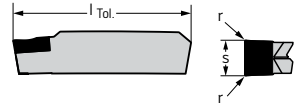

### Cutting inserts

Designation	s mm	r mm	l mm	f mm	S <sub>Tol</sub> mm	h <sub>Tol</sub> mm	N		O	
							WDN10	WDN10	DP	DP
 GX16-1F200N02FS-F1	2	0,2	16	0,04-0,12	±0,02	±0,02	☺	☺	☹	☹
GX24-2F300N02FS-F1	3	0,2	24	0,05-0,16	±0,02	±0,02	☺	☺	☹	☹
GX24-3F400N02FS-F1	4	0,2	24	0,06-0,22	±0,02	±0,02	☺	☺	☹	☹
GX24-3F500N02FS-F1	5	0,2	24	0,06-0,25	±0,02	±0,02	☺	☺	☹	☹
GX24-4F600N02FS-F1	6	0,2	24	0,06-0,28	±0,02	±0,02	☺	☺	☹	☹

 h<sub>Tol</sub> = Repeat accuracy when changing indexable inserts within one insert batch

 Radius tolerance r<sub>Tol</sub> = ±0.05 mm

Ordering example for the grade WDN10: GX16-1F200N02FS-F1 WDN10

DP = Polycrystalline diamond

## Grooving and recessing – cutting inserts

GX

Tiger-tec® Gold

GX...N

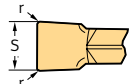
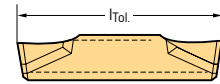

A2

## Cutting inserts

Designation	s mm	r mm	l mm	f mm	a <sub>p</sub> mm	S <sub>Tol</sub> mm	l <sub>Tol</sub> mm	P		M		S	
								HC		HC		HC	
								WSM23G	WSM23S	WSM23G	WSM23S	WSM23G	WSM23S
GX09-0E170N01-UF8	1.7	0.1	9	0.05-0.15	0.3-0.8	±0.02	±0.03	☺	☺	☺	☺	☺	☺
GX09-0E196N01-UF8	1.96	0.1	9	0.05-0.15	0.3-0.8	±0.02	±0.03	☺	☺	☺	☺	☺	☺
GX09-1E225N01-UF8	2.25	0.1	9	0.05-0.20	0.3-1.0	±0.02	±0.03	☺	☺	☺	☺	☺	☺
GX09-1E275N01-UF8	2.75	0.1	9	0.05-0.22	0.3-1.3	±0.02	±0.03	☺	☺	☺	☺	☺	☺
GX09-2E325N01-UF8	3.25	0.1	9	0.07-0.24	0.4-1.5	±0.02	±0.03	☺	☺	☺	☺	☺	☺
GX16-0E160N01-UF8	1.6	0.1	16	0.05-0.17	0.3-1.0	±0.02	±0.03	☺	☺	☺	☺	☺	☺
GX16-0E170N01-UF8	1.7	0.1	16	0.05-0.17	0.3-1.0	±0.02	±0.03	☺	☺	☺	☺	☺	☺
GX16-0E185N01-UF8	1.85	0.1	16	0.05-0.22	0.3-1.0	±0.02	±0.03	☺	☺	☺	☺	☺	☺
GX16-1E200N02-UF8	2	0.2	16	0.05-0.22	0.3-1.2	±0.02	±0.03	☺	☺	☺	☺	☺	☺
GX16-1E225N01-UF8	2.25	0.1	16	0.05-0.22	0.3-1.3	±0.02	±0.03	☺	☺	☺	☺	☺	☺
GX16-1E275N01-UF8	2.75	0.1	16	0.06-0.22	0.3-1.3	±0.02	±0.03	☺	☺	☺	☺	☺	☺
GX16-2E300N02-UF8	3	0.2	16	0.07-0.24	0.4-1.5	±0.02	±0.03	☺	☺	☺	☺	☺	☺
GX16-2E318N02-UF8	3.18	0.2	16	0.07-0.24	0.4-1.6	±0.02	±0.03	☺	☺	☺	☺	☺	☺
GX16-2E325N01-UF8	3.25	0.1	16	0.07-0.24	0.4-1.6	±0.02	±0.03	☺	☺	☺	☺	☺	☺
GX16-3E400N04-UF8	4	0.4	16	0.09-0.30	0.9-2.2	±0.02	±0.03	☺	☺	☺	☺	☺	☺
GX16-3E425N02-UF8	4.25	0.2	16	0.09-0.30	0.5-2.2	±0.02	±0.03	☺	☺	☺	☺	☺	☺
GX24-1E239N02-UF8	2.39	0.2	24	0.05-0.22	0.3-1.3	±0.02	±0.03	☺	☺	☺	☺	☺	☺
GX24-2E300N02-UF8	3	0.2	24	0.07-0.24	0.4-1.5	±0.02	±0.03	☺	☺	☺	☺	☺	☺
GX24-2E300N04-UF8	3	0.4	24	0.07-0.24	0.4-1.5	±0.02	±0.03	☺	☺	☺	☺	☺	☺
GX24-2E318N02-UF8	3.18	0.2	24	0.07-0.24	0.4-1.6	±0.02	±0.03	☺	☺	☺	☺	☺	☺
GX24-3E400N02-UF8	4	0.2	24	0.09-0.30	0.3-2.2	±0.02	±0.03	☺	☺	☺	☺	☺	☺
GX24-3E400N04-UF8	4	0.4	24	0.09-0.30	0.5-2.2	±0.02	±0.03	☺	☺	☺	☺	☺	☺
GX24-3E500N02-UF8	5	0.2	24	0.11-0.35	0.3-2.6	±0.02	±0.03	☺	☺	☺	☺	☺	☺
GX24-3E500N04-UF8	5	0.4	24	0.11-0.35	0.6-2.6	±0.02	±0.03	☺	☺	☺	☺	☺	☺
GX24-3E500N08-UF8	5	0.8	24	0.11-0.35	0.9-2.6	±0.02	±0.03	☺	☺	☺	☺	☺	☺
GX24-4E600N08-UF8	6	0.8	24	0.11-0.35	0.9-3.2	±0.02	±0.03	☺	☺	☺	☺	☺	☺

l<sub>Tol</sub> = Repeat accuracy when changing indexable inserts within one insert batchRadius tolerance r<sub>Tol</sub> = ±0.05 mm

Ordering example for the grade WSM23G: GX09-0E170N01-UF8 WSM23G

HC = Coated carbide

WALTER SELECT

Optimum indexable insert for → Good = ☺ → Average = ☹ → Poor = ☹ machining conditions

☺ ☹ ☹ / ★ = New addition to the product range

Single-, double- and multi-edged cutting inserts

A 395

## Grooving and recessing – cutting inserts

GX

Tiger-tec® Gold

GX...N

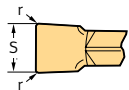
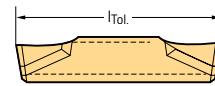

## Cutting inserts

Designation	s mm	r mm	l mm	f mm	a <sub>p</sub> mm	S <sub>Tol</sub> mm	l <sub>Tol</sub> mm	P					M					K		S					
								HC					HC					HC		HC					
								WKP23S	WSM23S	WSM33G	WSM33S	WSM43G	WSM43S	WSM23S	WSM33G	WSM33S	WSM43G	WSM43S	WKP23S	WSM23S	WSM33G	WSM33S	WSM43G	WSM43S	
GX09-1E200N02-UF4	2	0.2	9	0.10–0.15	0.3–1.0	±0.05	±0.15																		
GX09-2E300N03-UF4	3	0.3	9	0.10–0.20	0.4–1.5	±0.05	±0.15																		
GX16-1E200N02-UF4	2	0.2	16	0.10–0.15	0.3–1.2	±0.05	±0.15	☺	☺																
GX16-1E239N02-UF4	2,39	0.2	16	0.10–0.15	0.3–1.3	±0.05	±0.15	☺																	
GX16-1E250N02-UF4	2.5	0.2	16	0.10–0.18	0.3–1.3	±0.05	±0.15	☺																	
GX16-2E300N03-UF4	3	0.3	16	0.10–0.20	0.4–2.0	±0.05	±0.15	☺	☺																
GX16-3E400N04-UF4	4	0.4	16	0.10–0.30	0.5–2.8	±0.05	±0.15	☺																	
GX24-2E300N02-UF4	3	0.2	24	0.10–0.20	0.3–2.0	±0.05	±0.15																		
GX24-2E300N03-UF4	3	0.3	24	0.10–0.20	0.4–2.0	±0.05	±0.15	☺	☺																
GX24-2E318N03-UF4	3,18	0.3	24	0.10–0.20	0.4–2.0	±0.05	±0.15	☺																	
GX24-3E400N02-UF4	4	0.2	24	0.10–0.30	0.3–2.8	±0.05	±0.15																		
GX24-3E400N04-UF4	4	0.4	24	0.10–0.30	0.5–2.8	±0.05	±0.15	☺	☺																
GX24-3E400N08-UF4	4	0.8	24	0.10–0.30	0.9–2.8	±0.05	±0.15	☺																	
GX24-3E475N04-UF4	4,75	0.4	24	0.12–0.35	0.5–3	±0.05	±0.15																		
GX24-3E500N04-UF4	5	0.4	24	0.12–0.35	0.5–3.0	±0.05	±0.15	☺	☺																
GX24-3E500N08-UF4	5	0.8	24	0.12–0.35	0.9–3.0	±0.05	±0.15	☺																	
GX24-4E600N05-UF4	6	0.5	24	0.14–0.40	0.6–3.5	±0.05	±0.15	☺																	
GX24-4E600N08-UF4	6	0.8	24	0.14–0.40	0.9–3.5	±0.05	±0.15	☺																	
GX24-4E635N05-UF4	6,35	0.5	24	0.14–0.4	0.6–3.5	±0.05	±0.15																		
GX30-5E800N08-UF4	8	0.8	30	0.18–0.55	0.9–4.0	±0.05	±0.15																		
GX24-2F300N03-UF4	3	0.3	24	0.10–0.20	0.4–2.0	±0.05	±0.15																		
GX24-3F400N04-UF4	4	0.4	24	0.10–0.30	0.5–2.8	±0.05	±0.15																		
GX24-3F500N04-UF4	5	0.4	24	0.12–0.35	0.5–3.0	±0.05	±0.15																		
GX24-4F600N05-UF4	6	0.5	24	0.14–0.40	0.6–3.5	±0.05	±0.15																		
GX16-1E200N02-UD6	2	0.2	16	0.06–0.15	0.3–1.2	±0.05	±0.15																		
GX16-2E300N03-UD6	3	0.3	16	0.10–0.20	0.4–2.0	±0.05	±0.15																		
GX24-2E300N03-UD6	3	0.3	24	0.10–0.20	0.4–2.0	±0.05	±0.15		☺																
GX24-3E400N04-UD6	4	0.4	24	0.12–0.25	0.5–2.8	±0.05	±0.15		☺																
GX24-3E500N04-UD6	5	0.4	24	0.12–0.30	0.5–3.0	±0.05	±0.15		☺																
GX24-4E600N05-UD6	6	0.5	24	0.14–0.35	0.6–3.5	±0.05	±0.15																		

 l<sub>Tol</sub> = Repeat accuracy when changing indexable inserts within one insert batch

 Radius tolerance r<sub>Tol</sub> = ±0.05 mm

Ordering example for the grade WSM33G: GX09-1E200N02-UF4 WSM33G

HC = Coated carbide

WALTER SELECT

Optimum indexable insert for → Good = ☺ → Average = ☹ → Poor = ☹☹ machining conditions



# Grooving and recessing – cutting inserts

GX

Tiger-tec® Silver

GX...N

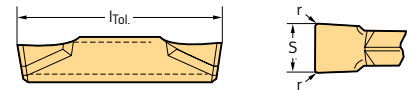

## Cutting inserts

Designation	s mm	r mm	l mm	f mm	a <sub>p</sub> mm	S <sub>Tol</sub> mm	l <sub>Tol</sub> mm	P		M	K		S	H		
								HC	HC	HC	HC	HC	HC			
								WKP13S	WKP23S	WKP33S	WSM33S	WKP13S	WKP23S	WKP33S	WSM33S	WKP13S
GX16-1E200N02-UD4	2	0,2	16	0,10-0,15	0,3-1,2	±0,05	±0,15	☉	☉	☉	☉	☉	☉	☉	☉	☉
GX16-2E300N03-UD4	3	0,3	16	0,10-0,20	0,4-2,0	±0,05	±0,15	☉	☉	☉	☉	☉	☉	☉	☉	☉
GX16-3E400N04-UD4	4	0,4	16	0,10-0,30	0,5-2,8	±0,05	±0,15	☉	☉	☉	☉	☉	☉	☉	☉	☉
GX24-2E300N03-UD4	3	0,3	24	0,10-0,20	0,4-2,0	±0,05	±0,15	☉	☉	☉	☉	☉	☉	☉	☉	☉
GX24-2E318N03-UD4	3,18	0,3	24	0,10-0,20	0,4-2,0	±0,05	±0,15	☉	☉	☉	☉	☉	☉	☉	☉	☉
GX24-3E400N04-UD4	4	0,4	24	0,10-0,30	0,5-2,8	±0,05	±0,15	☉	☉	☉	☉	☉	☉	☉	☉	☉
GX24-3E400N08-UD4	4	0,8	24	0,10-0,30	0,9-2,8	±0,05	±0,15	☉	☉	☉	☉	☉	☉	☉	☉	☉
GX24-3E500N04-UD4	5	0,4	24	0,12-0,35	0,5-3,0	±0,05	±0,15	☉	☉	☉	☉	☉	☉	☉	☉	☉
GX24-3E500N08-UD4	5	0,8	24	0,12-0,35	0,9-3,0	±0,05	±0,15	☉	☉	☉	☉	☉	☉	☉	☉	☉
GX24-4E600N05-UD4	6	0,5	24	0,14-0,40	0,6-3,5	±0,05	±0,15	☉	☉	☉	☉	☉	☉	☉	☉	☉
GX24-4E600N08-UD4	6	0,8	24	0,14-0,40	0,9-3,5	±0,05	±0,15	☉	☉	☉	☉	☉	☉	☉	☉	☉
GX30-5E800N08-UD4	8	0,8	30	0,14-0,40	0,9-4,0	±0,05	±0,15	☉	☉	☉	☉	☉	☉	☉	☉	☉
GX30-5E800N12-UD4	8	1,2	30	0,14-0,40	1,3-4,0	±0,05	±0,15	☉	☉	☉	☉	☉	☉	☉	☉	☉
GX16-1E200N02-UA4	2	0,2	16	0,08-0,15	0,3-1,2	±0,05	±0,15	☉	☉	☉	☉	☉	☉	☉	☉	☉
GX16-2E300N03-UA4	3	0,3	16	0,10-0,22	0,4-2,0	±0,05	±0,15	☉	☉	☉	☉	☉	☉	☉	☉	☉
GX16-3E400N04-UA4	4	0,4	16	0,10-0,35	0,5-2,8	±0,05	±0,15	☉	☉	☉	☉	☉	☉	☉	☉	☉
GX24-2E300N03-UA4	3	0,3	24	0,10-0,22	0,4-2,0	±0,05	±0,15	☉	☉	☉	☉	☉	☉	☉	☉	☉
GX24-3E400N04-UA4	4	0,4	24	0,10-0,35	0,5-2,8	±0,05	±0,15	☉	☉	☉	☉	☉	☉	☉	☉	☉
GX24-3E500N04-UA4	5	0,4	24	0,12-0,35	0,5-3,0	±0,05	±0,15	☉	☉	☉	☉	☉	☉	☉	☉	☉
GX24-4E600N05-UA4	6	0,5	24	0,14-0,40	0,6-3,5	±0,05	±0,15	☉	☉	☉	☉	☉	☉	☉	☉	☉

l<sub>Tol</sub> = Repeat accuracy when changing indexable inserts within one insert batch  
 Radius tolerance r<sub>Tol</sub> = ±0.05 mm  
 Ordering example for the grade WKP23S: GX16-1E200N02-UD4 WKP23S

HC = Coated carbide

# Grooving and recessing – cutting inserts

GX

Tiger-tec® Silver

R...VG7

L...VG7



## Cutting inserts

Designation	s mm	r mm	κ	l mm	f mm	a <sub>p</sub> mm	S <sub>Tol</sub> mm	l <sub>Tol</sub> mm	P		M	S		
									HC	HC	HC	HC	HC	
									WSM23S	WSM33S	WSM23S	WSM33S	WSM23S	WSM33S
GX24-2E280R02-VG7	2,8	0,2	50	24	0,05-0,12	0,2-2,0	±0,05	±0,15	☉	☉	☉	☉	☉	☉
GX24-2E280R04-VG7	2,8	0,4	50	24	0,08-0,25	0,2-2,5	±0,05	±0,15	☉	☉	☉	☉	☉	☉

l<sub>Tol</sub> = Repeat accuracy when changing indexable inserts within one insert batch  
 Radius tolerance r<sub>Tol</sub> = ±0.05 mm  
 Ordering example for the grade WSM23S: GX24-2E280R02-VG7 WSM23S

HC = Coated carbide

**WALTER SELECT** Optimum indexable insert for → Good = ☉ → Average = ☉ → Poor = ☉ machining conditions

☉ ☉ ☉ / \* = New addition to the product range

Single-, double- and multi-edged cutting inserts A 397

## Grooving and recessing – cutting inserts

GX

Tiger-tec® Silver

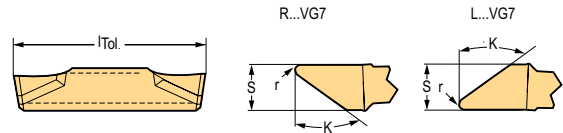

## Cutting inserts

Designation	s mm	r mm	k	l mm	f mm	a <sub>p</sub> mm	S <sub>Tol</sub> mm	l <sub>Tol</sub> mm	P		M		S	
									WSM23S	WSM33S	WSM23S	WSM33S	WSM23S	WSM33S
GX24-2E280L02-VG7	2,8	0,2	50	24	0,05–0,12	0,2–0,0	±0,05	±0,15	☺	☺	☺	☺	☺	☺

l<sub>Tol</sub> = Repeat accuracy when changing indexable inserts within one insert batch  
 Radius tolerance r<sub>Tol</sub> = ±0.05 mm  
 Ordering example for the grade WSM23S: GX24-2E280R02-VG7 WSM23S

HC = Coated carbide

## Grooving and copy turning – cutting inserts

GX

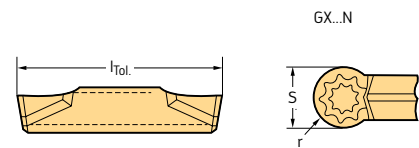

## Cutting inserts

Designation	s mm	r mm	l mm	f mm	a <sub>p</sub> mm	S <sub>Tol</sub> mm	l <sub>Tol</sub> mm	P		M		K	N	S				
								WSM13S	WKP23S	WSM23G	WSM23S	WSM33S	WSM13S	WSM23G	WSM23S	WSM33S	WKP23S	WK1
GX24-4R300N-RK8	6	3	25,4	0,10–0,60	0,1–4,0	±0,02	±0,05						☺					

l<sub>Tol</sub> = Repeat accuracy when changing indexable inserts within one insert batch  
 Radius tolerance r<sub>Tol</sub> = ±0.05 mm  
 Ordering example for the grade WK1: GX24-4R300N-RK8 WK1

HC = Coated carbide  
 HW = Uncoated carbide

# Grooving and copy turning – cutting inserts

GX

Tiger-tec® Gold

GX..N

A2

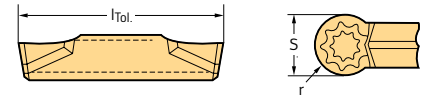

## Cutting inserts

Designation	s mm	r mm	l mm	f mm	ap mm	S <sub>Tol</sub>	l <sub>Tol</sub> mm	P				M				K		N		S						
								WSM13S	WKP23S	WSM23G	WSM23S	WSM23S	WSM23S	WSM33S	WKP23S	WK1	HW	WSM13S	WSM23G	WSM23S	WSM23S	WSM33S	WSM13S	WSM23G	WSM23S	WSM33S
	GX09-1E200N10-RF8	2	1	9	0,05-0,17	0,1-1,0	±0,02	±0,02			☺															
	GX09-1E239N12-RF8	2,39	1,2	9	0,05-0,20	0,2-1,2	±0,02	±0,02			☺															
	GX16-1E200N10-RF8	2	1	16	0,08-0,25	0,1-1,0	±0,05	±0,05	☺			☺														
	GX16-1E239N12-RF8	2,39	1,200	16	0,08-0,28	0,2-1,2	±0,02	±0,02				☺														
	GX16-2E300N15-RF8	3	1,5	16	0,10-0,30	0,1-1,5	±0,02	±0,02	☺			☺														
	GX16-3E400N20-RF8	4	2	16	0,12-0,45	0,1-2,0	±0,02	±0,02				☺														
	GX24-2E300N15-RF8	3	1,5	24	0,10-0,30	0,1-1,5	±0,02	±0,02	☺			☺														
	GX24-2E318N16-RF8	3,18	1,59	24	0,10-0,30	0,1-1,5	±0,02	±0,02				☺														
	GX24-3E400N20-RF8	4	2	24	0,12-0,45	0,1-2,0	±0,02	±0,02	☺			☺														
	GX24-3E500N25-RF8	5	2,5	24	0,15-0,50	0,1-2,5	±0,02	±0,02	☺			☺														
GX24-4E600N30-RF8	6	3	24	0,15-0,55	0,1-3,0	±0,02	±0,02	☺			☺															
GX30-5E800N40-RF8	8	4	30	0,18-0,60	0,2-4,0	±0,02	±0,02	☺			☺															
	GX24-2E300N15-RF7	3	1,5	24	0,10-0,33	0,1-1,5	±0,05	±0,15	☺			☺														
	GX24-3E400N20-RF7	4	2	24	0,12-0,48	0,1-2,0	±0,05	±0,15	☺			☺														
	GX24-3E500N25-RF7	5	2,5	24	0,12-0,53	0,1-2,5	±0,05	±0,15	☺			☺														
	GX24-2F300N15-RF7	3	1,5	24	0,10-0,33	0,1-1,5	±0,05	±0,15	☺			☺														
	GX24-3F400N20-RF7	4	2	24	0,12-0,48	0,1-2,0	±0,05	±0,15	☺			☺														
	GX24-3F500N25-RF7	5	2,5	24	0,12-0,53	0,1-2,5	±0,05	±0,15	☺			☺														
	GX16-1E200N10-RD4	2	1	16	0,08-0,25	0,2-1,0	±0,05	±0,15			☺															
	GX16-1E239N12-RD4	2,39	1,2	16	0,08-0,25	0,2-1	±0,05	±0,15				☺														
	GX16-2E300N15-RD4	3	1,5	16	0,10-0,35	0,5-1,5	±0,05	±0,15				☺														
	GX24-2E300N15-RD4	3	1,5	24	0,10-0,35	0,5-1,5	±0,05	±0,15	☺			☺														
	GX24-2E318N16-RD4	3,18	1,59	24	0,10-0,35	0,5-1,5	±0,05	±0,15	☺			☺														
	GX24-3E400N20-RD4	4	2	24	0,15-0,50	0,5-2,0	±0,05	±0,15	☺			☺														
	GX24-3E475N24-RD4	4,75	2,38	24	0,17-0,6	0,5-2,3	±0,05	±0,15				☺														
	GX24-3E500N25-RD4	5	2,5	24	0,17-0,60	0,5-2,5	±0,05	±0,15	☺			☺														
	GX24-4E600N30-RD4	6	3	24	0,17-0,70	0,5-3,0	±0,05	±0,15	☺			☺														
	GX24-4E635N32-RD4	6,35	3,18	24	0,17-0,7	0,5-3	±0,05	±0,15				☺														
GX30-5E800N40-RD4	8	4	30	0,20-0,80	0,6-4,0	±0,05	±0,15	☺			☺															
	GX24-3F500N25-RD4	5	2,5	24	0,17-0,60	0,5-0,0	±0,05	±0,15	☺			☺														

l<sub>Tol</sub> = Repeat accuracy when changing indexable inserts within one insert batch

Radius tolerance r<sub>Tol</sub> = ±0.05 mm

Ordering example for the grade WK1: GX24-4R300N-RK8 WK1

HC = Coated carbide  
HW = Uncoated carbide

# CBN – grooving and copy turning

## GX

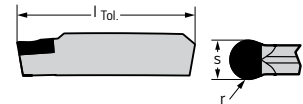

### Cutting inserts

Designation	s mm	r mm	l mm	f mm	S <sub>Tol</sub> mm	h <sub>Tol</sub> mm	S	H	
							BH	BL	
							WBS10	WBH20	
	GX24-2F300N15EM-1	3	1.5	24	0.10–0.15	±0.02	±0.03	☺	
	GX24-3F400N20EM-1	4	2	24	0.10–0.20	±0.02	±0.03	☺	
	GX24-3F500N25EM-1	5	2.5	24	0.10–0.25	±0.02	±0.03	☺	
	GX24-4F600N30EM-1	6	3	24	0.10–0.30	±0.02	±0.03	☺	
	GX24-2F300N15TM-1	3	1.5	24	0.02–0.10	±0.02	±0.03		☺
	GX24-3F400N20TM-1	4	2	24	0.02–0.12	±0.02	±0.03		☺
	GX24-3F500N25TM-1	5	2.5	24	0.02–0.14	±0.02	±0.03		☺
	GX24-4F600N30TM-1	6	3	24	0.02–0.15	±0.02	±0.03		☺

l<sub>Tol</sub> = Repeat accuracy when changing indexable inserts within one insert batch  
 Radius tolerance r<sub>Tol</sub> = ±0.05 mm  
 Ordering example for the grade WBS10: GX24-2F300N15EM-1 WBS10

BH = CBN with high CBN content  
 BL = CBN with low CBN content

# PCD – grooving and copy turning

## GX

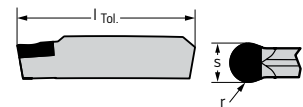

### Cutting inserts

Designation	s mm	r mm	l mm	f mm	S <sub>Tol</sub> mm	h <sub>Tol</sub> mm	N	O	
							DP	DP	
							WDN10	WDN10	
	GX16-1F200N10FS-M1	2	1	16	0.05–0.25	±0.02	±0.02	☺	☺
	GX24-2F300N15FS-M1	3	1.5	24	0.05–0.30	±0.02	±0.02	☺	☺
	GX24-3F400N20FS-M1	4	2	24	0.05–0.35	±0.02	±0.02	☺	☺
	GX24-3F500N25FS-M1	5	2.5	24	0.05–0.40	±0.02	±0.02	☺	☺
	GX24-4F600N30FS-M1	6	3	24	0.05–0.50	±0.02	±0.02	☺	☺

l<sub>Tol</sub> = Repeat accuracy when changing indexable inserts within one insert batch  
 Radius tolerance r<sub>Tol</sub> = ±0.05 mm  
 Ordering example for the grade WDN10: GX16-1F200N10FS-M1 WDN10

DP = Polycrystalline diamond

# Axial grooving – cutting inserts



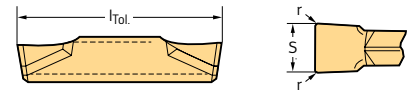

GX

Tiger-tec® Silver

GX...N



## Cutting inserts

Designation	s mm	r mm	f mm	S <sub>Tol</sub> mm	h <sub>Tol</sub> mm	P		M		K		S	
						HC	WKP23S	HC	WSM33S	HC	WKP23S	HC	WSM33S
 GX24-3E500R04-AF5	5	0,4	0,15-0,30	±0,05	±0,15	☺	☺	☺	☺	☺	☺	☺	☺
 GX24-3E500L04-AF5	5	0,4	0,15-0,30	±0,05	±0,15	☺	☺	☺	☺	☺	☺	☺	☺
 GX24-3F500R04-AF5	5	0,4	0,15-0,30	±0,05	±0,15		☺	☺	☺	☺	☺	☺	☺
 GX24-3F500L04-AF5	5	0,4	0,15-0,30	±0,05	±0,15		☺	☺	☺	☺	☺	☺	☺

When using the GX24-...R...-AF5 cutting insert, the G1111...R tool should be used  
 When using the GX24-...L...-AF5 cutting insert, the G1111...L tool should be used  
 Ordering example for the grade WKP23S: GX24-3E500R04-AF5 WKP23S

HC = Coated carbide

# Semi-finished blanks for special shapes

GX



## Cutting inserts

Designation	s mm	l mm	P		M		S	
			HW	WMG40	HW	WMG40	HW	WMG40
 GX24-2E4.80N	4,8	24,6	☺	☺	☺	☺	☺	☺
GX24-3E6.30N	6,3	24,6	☺	☺	☺	☺	☺	☺
GX24-4E8.30N	8,3	24,6	☺	☺	☺	☺	☺	☺
GX24-5E10.30N	10,3	24,6	☺	☺	☺	☺	☺	☺

Grade WMG40 has the ISO application ranges P30, M30 and S30  
 Ordering example for the grade WMG40: GX24-2E4.80N WMG40

HW = Uncoated carbide

WALTER SELECT

Optimum indexable insert for → Good = ☺ → Average = ☹ → Poor = ☹ machining conditions

☺ ☹ ☹ / \* = New addition to the product range

Single-, double- and multi-edged cutting inserts A 401







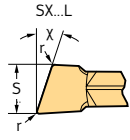
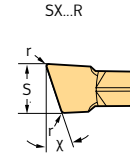
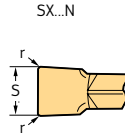
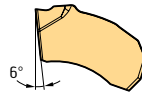

## Grooving and parting off – cutting inserts

## SX

## Tiger-tec® Gold



## Cutting inserts

Designation	s mm	r mm	κ	f mm	S <sub>Tol</sub> mm	l <sub>Tol</sub> mm	P				M			K	N	S	
							HC				HC			HC	HW	HC	
							WKP23S	WSM23G	WSM33G	WSM43G	WSM23G	WSM33G	WSM43G	WKP23S	WK1	WSM23G	WSM33G
 SX-2E200N02-CK8 SX-3E300N02-CK8 SX-4E400N02-CK8 SX-5E500N04-CK8	2	0.2		0.04–0.12	±0.02	±0.05								☺			
	3	0.2		0.08–0.20	±0.02	±0.05								☺			
	4	0.2		0.10–0.22	±0.02	±0.05								☺			
	5	0.4		0.10–0.25	±0.02	±0.05								☺			
 SX-2E200N02-CF6 SX-3E300N02-CF6	2	0.2		0.03–0.14	±0.05	±0.1			☺	☺						☺	☺
	3	0.2		0.04–0.23	±0.05	±0.1			☺	☺						☺	☺
 SX-1E150N01-CF5 SX-2E200N02-CF5 SX-3E300N02-CF5 SX-3E310N03-CF5 SX-4E400N02-CF5 SX-5E500N04-CF5 SX-6E600N04-CF5	1.5	0.15		0.03–0.10	±0.05	±0.1			☺	☺						☺	
	2	0.2		0.04–0.12	±0.05	±0.1			☺	☺						☺	☺
	3	0.2		0.08–0.20	±0.05	±0.1		☺	☺	☺						☺	☺
	3.1	0.3		0.08–0.20	±0.05	±0.1			☺	☺						☺	
	4	0.2		0.10–0.22	±0.05	±0.1			☺	☺						☺	☺
	5	0.4		0.10–0.25	±0.05	±0.1			☺	☺						☺	☺
 SX-2E200R6-CF5 SX-3E300R6-CF5 SX-3E300R15-CF5 SX-4E400R6-CF5	2	0.2	6	0.04–0.10	±0.05	±0.1			☺	☺						☺	
	3	0.2	6	0.08–0.17	±0.05	±0.1			☺	☺						☺	☺
	3	0	15	0.05–0.15	±0.05	±0.1			☺	☺						☺	
	4	0.2	6	0.10–0.20	±0.05	±0.1			☺	☺						☺	
 SX-3E300L6-CF5 SX-4E400L6-CF5	3	0.2	6	0.08–0.17	±0.05	±0.1			☺	☺						☺	☺
	4	0.2	6	0.10–0.20	±0.05	±0.1			☺	☺						☺	
 SX-1E150N01-CE4 SX-2E200N02-CE4 SX-2E260N03-CE4 SX-3E300N02-CE4 SX-3E310N03-CE4 SX-4E400N02-CE4 SX-4E410N03-CE4 SX-4E480N03-CE4 SX-5E500N04-CE4 SX-6E600N04-CE4 SX-8E800N08-CE4 SX-10E1000N08-CE4	1.5	0.15		0.03–0.12	±0.05	±0.1			☺	☺						☺	
	2	0.2		0.06–0.15	±0.05	±0.1		☺	☺	☺						☺	☺
	2.6	0.3		0.06–0.18	±0.05	±0.1			☺	☺						☺	
	3	0.2		0.09–0.30	±0.05	±0.1		☺	☺	☺						☺	☺
	3.1	0.3		0.09–0.30	±0.05	±0.1			☺	☺						☺	
	4	0.2		0.10–0.32	±0.05	±0.1		☺	☺	☺						☺	☺
	4.1	0.3		0.10–0.32	±0.05	±0.1			☺	☺						☺	
	4.8	0.3		0.12–0.35	±0.05	±0.1			☺	☺						☺	
	5	0.4		0.12–0.35	±0.05	±0.1		☺	☺	☺						☺	☺
	6	0.4		0.12–0.40	±0.05	±0.1		☺	☺	☺						☺	☺
	8	0.8		0.20–0.55	±0.05	±0.1		☺	☺	☺						☺	
	10	0.8		0.25–0.60	±0.05	±0.1			☺	☺						☺	
 SX-2E200R6-CE4 SX-3E300R6-CE4 SX-4E400R6-CE4 SX-5E500R6-CE4 SX-6E600R6-CE4	2	0.2	6	0.06–0.10	±0.05	±0.1			☺	☺						☺	
	3	0.2	6	0.09–0.20	±0.05	±0.1		☺	☺	☺						☺	
	4	0.2	6	0.10–0.22	±0.05	±0.1			☺	☺						☺	☺
	5	0.4	6	0.12–0.25	±0.05	±0.1			☺	☺						☺	
	6	0.4	6	0.12–0.30	±0.05	±0.1			☺	☺						☺	
 SX-3E300L6-CE4 SX-4E400L6-CE4 SX-6E600L6-CE4	3	0.2	6	0.09–0.20	±0.05	±0.1			☺	☺						☺	
	4	0.2	6	0.10–0.22	±0.05	±0.1			☺	☺						☺	
	6	0.4	6	0.12–0.30	±0.05	±0.1			☺	☺						☺	

 l<sub>Tol</sub> = Repeat accuracy when changing indexable inserts within one insert batch

 Radius tolerance r<sub>Tol</sub> = ±0.05 mm

Ordering example for the grade WK1: SX-2E200N02-CK8 WK1

HC = Coated carbide

HW = Uncoated carbide

## Grooving and recessing – cutting inserts

SX

**Tiger-tec® Gold**

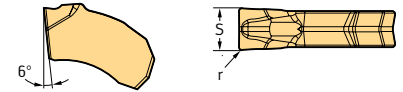

### Cutting inserts

Designation	s mm	r mm	l mm	f mm	S <sub>Tol</sub> mm	l <sub>Tol</sub> mm	P		M		K	S		
							HC		HC		HC	HC		
							WKP23S	WSM33G	WSM43G	WSM33G	WSM43G	WKP23S	WSM33G	WSM43G
 SX-8E800N08-UF4	8	0,8	17,4	0,18–0,55	±0,05	±0,1	☺	☺	☺	☺	☺	☺	☺	☺

l<sub>Tol</sub> = Repeat accuracy when changing indexable inserts within one insert batch  
 Radius tolerance r<sub>Tol</sub> = ±0.05 mm  
 Ordering example for the grade WKP23S: SX-8E800N08-UF4 WKP23S  
 Ordering example for the grade WSM33G: SX-8E800N08-UF4 WSM33G

HC = Coated carbide



## Slitting – cutting inserts

SX

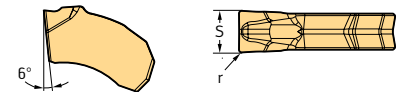
**Tiger-tec® Gold**



### Cutting inserts

Designation	s mm	r mm	f mm	S <sub>Tol</sub> mm	l <sub>Tol</sub> mm	P		M		N	S		
						HC		HC		HW	HC		
							WSM33G	WSM43G	WSM33G	WSM43G	WK1	WSM33G	WSM43G
 SX-1E150N01-SK8	1,5	0,1	0,03–0,08	±0,02	±0,05						☺		
SX-2E200N02-SK8	2	0,2	0,05–0,10	±0,02	±0,05						☺		
SX-3E300N02-SK8	3	0,2	0,05–0,15	±0,02	±0,05						☺		
SX-4E400N02-SK8	4	0,2	0,05–0,20	±0,02	±0,05						☺		
 SX-1E150N01-SF5	1,5	0,15	0,03–0,10	±0,05	±0,1	☺	☺				☺	☺	
SX-2E200N02-SF5	2	0,2	0,06–0,15	±0,05	±0,1	☺	☺	☺	☺		☺	☺	
SX-3E300N02-SF5	3	0,2	0,08–0,20	±0,05	±0,1	☺	☺	☺	☺		☺	☺	
SX-4E400N02-SF5	4	0,2	0,10–0,22	±0,05	±0,1	☺	☺	☺	☺		☺	☺	
SX-5E500N04-SF5	5	0,4	0,10–0,25	±0,05	±0,1	☺	☺	☺	☺		☺	☺	

l<sub>Tol</sub> = Repeat accuracy when changing indexable inserts within one insert batch  
 Radius tolerance r<sub>Tol</sub> = ±0.05 mm  
 Ordering example for the grade WK1: SX-1E150N01-SK8 WK1

HC = Coated carbide  
 HW = Uncoated carbide

**WALTER SELECT** Optimum indexable insert for → Good = ☺ → Average = ☹ → Poor = ☹ machining conditions

☺ ☹ ☹ / \* = New addition to the product range

Single-, double- and multi-edged cutting inserts A 403

## Grooving and parting off – cutting inserts

UX

Tiger-tec® Silver

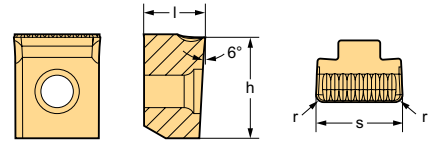

## Cutting inserts

Designation	s mm	r mm	l mm	f mm	S <sub>Tol</sub> mm	h <sub>Tol</sub> mm	P	K
							HC	HC
UX-12E1200N10-GD2	12	1	8,6	0,20-0,40	±0,2	±0,1	WKP33S	WKP33S
UX-19E1900N15-GD2	19	1,5	13,6	0,25-0,60	±0,2	±0,1	WKP33S	WKP33S



$l_{Tol}$  = Repeat accuracy when changing indexable inserts within one insert batch  
 Radius tolerance  $r_{Tol} = \pm 0.05$  mm  
 Ordering example for the grade WKP33S: UX-12E1200N10-GD2 WKP33S

HC = Coated carbide



## Grooving and parting off – cutting inserts

### WT

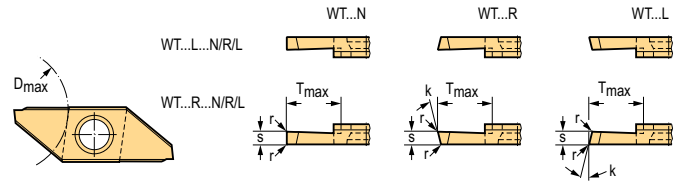

### Cutting inserts

Designation	s mm	r mm	k	T <sub>max</sub> mm	D <sub>max</sub> mm	l mm	f mm	S <sub>Tol</sub> mm	H <sub>tol</sub> mm	P	M	N	S
										HC	HC	HW	HC
										WSM23X	WSM23X	WN23	WSM23X
WT26-R070N00-CD8	0.7	0.05		4.3		25	0.02–0.07	±0.02	±0.03	☺	☺	☺	☺
WT26-R100N00-CD8	1	0.05		6.3		25	0.02–0.10	±0.02	±0.03	☺	☺	☺	☺
WT26-R150N00-CD8	1.5	0.05		6.3		25	0.02–0.13	±0.02	±0.03	☺	☺	☺	☺
WT26-R200N00-CD8	2	0.05		8.5	35	25	0.02–0.14	±0.02	±0.03	☺	☺	☺	☺
WT26-R070R15-CD8	0.7	0.05	15	4.3		25	0.02–0.07	±0.02	±0.03	☺	☺	☺	☺
WT26-R100R15-CD8	1	0.05	15	6.3		25	0.02–0.10	±0.02	±0.03	☺	☺	☺	☺
WT26-R150R15-CD8	1.5	0.05	15	6.3		25	0.02–0.13	±0.02	±0.03	☺	☺	☺	☺
WT26-R200R15-CD8	2	0.05	15	8.5	35	25	0.02–0.14	±0.02	±0.03	☺	☺	☺	☺
WT26-L070N00-CD8	0.7	0.05		4.3		25	0.02–0.07	±0.02	±0.03	☺	☺	☺	☺
WT26-L100N00-CD8	1	0.05		6.3		25	0.02–0.10	±0.02	±0.03	☺	☺	☺	☺
WT26-L150N00-CD8	1.5	0.05		6.3		25	0.02–0.13	±0.02	±0.03	☺	☺	☺	☺
WT26-L200N00-CD8	2	0.05		8.5	35	25	0.02–0.14	±0.02	±0.03	☺	☺	☺	☺
WT26-L070R15-CD8	0.7	0.05	15	4.3		25	0.02–0.07	±0.02	±0.03	☺	☺	☺	☺
WT26-L100R15-CD8	1	0.05	15	6.3		25	0.02–0.10	±0.02	±0.03	☺	☺	☺	☺
WT26-L150R15-CD8	1.5	0.05	15	6.3		25	0.02–0.13	±0.02	±0.03	☺	☺	☺	☺
WT26-L200R15-CD8	2	0.05	15	8.5	35	25	0.02–0.14	±0.02	±0.03	☺	☺	☺	☺

Radius tolerance  $r_{Tol} = \pm 0.05$  mm

Ordering example for the grade WSM23X: WT26-R070N00-CD8 WSM23X

HC = Coated carbide  
HW = Uncoated carbide

## Grooving and parting off – cutting inserts

### WT

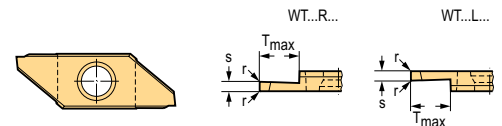

### Cutting inserts

Designation	s mm	r mm	T <sub>max</sub> mm	l mm	f mm	S <sub>Tol</sub> mm	H <sub>tol</sub> mm	P	M	S
								HC	HC	HC
								WSM23X	WSM23X	WSM23X
WT26-R050N00-GD8	0.5	0.05	1.3	25	0.02–0.06	±0.02	±0.03	☺	☺	☺
WT26-R075N00-GD8	0.75	0.05	2.5	25	0.02–0.07	±0.02	±0.03	☺	☺	☺
WT26-R100N00-GD8	1	0.05	2.7	25	0.02–0.10	±0.02	±0.03	☺	☺	☺
WT26-R125N00-GD8	1.25	0.05	2.7	25	0.02–0.12	±0.02	±0.03	☺	☺	☺
WT26-R150N00-GD8	1.5	0.05	3.7	25	0.02–0.13	±0.02	±0.03	☺	☺	☺
WT26-R175N00-GD8	1.75	0.05	3.7	25	0.02–0.13	±0.02	±0.03	☺	☺	☺
WT26-R200N00-GD8	2	0.05	3.7	25	0.02–0.14	±0.02	±0.03	☺	☺	☺
WT26-R250N00-GD8	2.5	0.05	3.7	25	0.02–0.16	±0.02	±0.03	☺	☺	☺

Radius tolerance  $r_{Tol} = \pm 0.05$  mm

Ordering example for the grade WSM23X: WT26-R050N00-GD8 WSM23X

HC = Coated carbide

#### WALTER SELECT

Optimum indexable insert for → Good = ☺ → Average = ☹ → Poor = ☹ machining conditions

☺ ☹ ☹ / ★ = New addition to the product range

Single-, double- and multi-edged cutting inserts A 405

## Grooving and parting off – cutting inserts

### WT

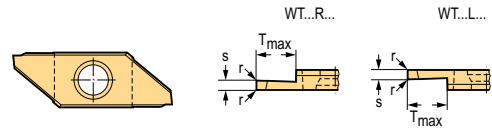

#### Cutting inserts

Designation	s mm	r mm	T <sub>max</sub> mm	l mm	f mm	S <sub>Tol</sub> mm	h <sub>Tol</sub> mm	P	M	S
								HC	HC	HC
								WSM23X	WSM23X	WSM23X
 WT26-L050N00-GD8	0,5	0,05	1,3	25	0,02–0,06	±0,02	±0,03	☺	☺	☺
WT26-L075N00-GD8	0,75	0,05	2,5	25	0,02–0,07	±0,02	±0,03	☺	☺	☺
WT26-L100N00-GD8	1	0,05	2,7	25	0,02–0,10	±0,02	±0,03	☺	☺	☺
WT26-L150N00-GD8	1,5	0,05	3,7	25	0,02–0,13	±0,02	±0,03	☺	☺	☺
WT26-L200N00-GD8	2	0,05	3,7	25	0,02–0,14	±0,02	±0,03	☺	☺	☺

 Radius tolerance  $r_{Tol} = \pm 0,05$  mm

Ordering example for the grade WSM23X: WT26-R050N00-GD8 WSM23X



HC = Coated carbide

## Grooving and recessing – cutting inserts

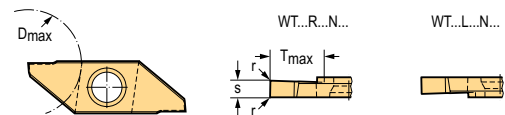
### WT



#### Cutting inserts

Designation	s mm	r mm	T <sub>max</sub> mm	D <sub>max</sub> mm	l mm	f mm	a <sub>p</sub> mm	S <sub>Tol</sub> mm	h <sub>Tol</sub> mm	P	M	S
										HC	HC	HC
										WSM23X	WSM23X	WSM23X
 WT26-R100N00-UA8	1	0,05	6,3		25	0,02–0,14	0,1–1,5	±0,02	±0,03	☺	☺	☺
WT26-R150N00-UA8	1,5	0,05	6,3	35	25	0,02–0,14	0,1–1,5	±0,02	±0,03	☺	☺	☺
WT26-R200N00-UA8	2	0,05	8,2	35	25	0,02–0,14	0,1–3,0	±0,02	±0,03	☺	☺	☺
WT26-R250N00-UA8	2,5	0,05	8,2	35	25	0,02–0,16	0,1–3,0	±0,02	±0,03	☺	☺	☺
 WT26-L200N00-UA8	2	0,05	8,2		25	0,02–0,14	0,1–3,0	±0,02	±0,03	☺	☺	☺

 Radius tolerance  $r_{Tol} = \pm 0,05$  mm

Ordering example for the grade WSM23X: WT26-R100N00-UA8 WSM23X

HC = Coated carbide

## Forward turning - cutting inserts

### WT

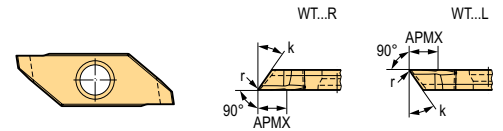

#### Cutting inserts

Designation	s mm	r mm	k	l mm	f mm	APMX mm	S <sub>Tol</sub> mm	l <sub>Tol</sub> mm	P	M	N	S
									HC	HC	HW	HC
									WSM23X	WSM23X	WN23	WSM23X
 WT26-R300L003-DG8	3	0.03	35	25	0,02-0,10	4	±0,02	±0,03	☺	☺	☺	☺
WT26-R300L005-DG8	3	0.05	35	25	0,02-0,13	4	±0,02	±0,03	☺	☺	☺	☺
WT26-R300L010-DG8	3	0.1	35	25	0,02-0,14	4	±0,02	±0,03	☺	☺	☺	☺
WT26-R300L020-DG8	3	0.2	35	25	0,02-0,16	4	±0,02	±0,03	☺	☺	☺	☺

Radius tolerance  $r_{Tol} = \pm 0.05$  mm

Ordering example for the grade WN23: WT26-R300L003-DG8 WN23

HC = Coated carbide

HW = Uncoated carbide

## Reverse turning - cutting inserts

### WT

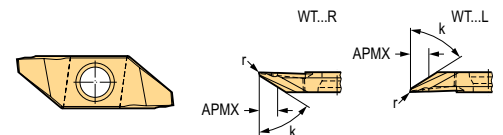

#### Cutting inserts

Designation	s mm	r mm	k	l mm	f mm	APMX mm	S <sub>Tol</sub> mm	l <sub>Tol</sub> mm	P	M	N	S
									HC	HC	HW	HC
									WSM23X	WSM23X	WN23	WSM23X
 WT26-R300R003-VG8	3	0.03	59	25	0,02-0,10	4	±0,02	±0,03	☺	☺	☺	☺
WT26-R300R005-VG8	3	0.05	59	25	0,02-0,13	4	±0,02	±0,03	☺	☺	☺	☺
WT26-R300R010-VG8	3	0.1	59	25	0,02-0,14	4	±0,02	±0,03	☺	☺	☺	☺
WT26-R300R020-VG8	3	0.2	59	25	0,02-0,16	4	±0,02	±0,03	☺	☺	☺	☺

Radius tolerance  $r_{Tol} = \pm 0.05$  mm

Ordering example for the grade WN23: WT26-R300R003-VG8 WN23

HC = Coated carbide

HW = Uncoated carbide

# Grooving and copy turning – cutting inserts

## WT

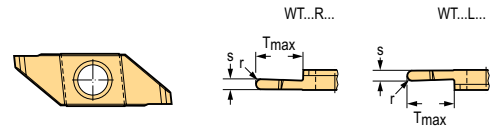

### Cutting inserts

Designation	s mm	r mm	T <sub>max</sub> mm	l mm	f mm	a <sub>p</sub> mm	S <sub>Tol</sub> mm	l <sub>Tol</sub> mm	P	M	S
									HC	HC	HC
									WSM23X	WSM23X	WSM23X
 WT26-L125N06-RA8 WT26-L160N08-RA8	1,25	0,63	5	25	0,02–0,12	0,10–0,60	±0,02	±0,03	☺	☺	☺
	1,6	0,8	7,5	25	0,02–0,14	0,10–0,80	±0,02	±0,03	☺	☺	☺

 Radius tolerance  $r_{Tol} = \pm 0.05$  mm

Ordering example for the grade WSM23X: WT26-L125N06-RA8 WSM23X



HC = Coated carbide

## External thread turning inserts – 60° partial profile

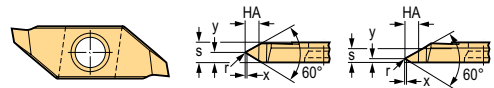
### WT



### Indexable inserts

Designation	P mm	P in	r mm	HA mm	l mm	X mm	Y mm	P	M	S
								HC	HC	HC
								WSM23X	WSM23X	WSM23X
 WT26-R-ER-AG60R WT26-R-ER-AG60	0,35–1	72–24	0,05	0,75	25	0,05	0,6	☺	☺	☺
	0,35–2	72–12	0,05	1,5	25	0,05	1,59	☺	☺	☺
 WT26-L-EL-AG60	0,35–2	72–12	0,05	1,5	25	0,05	1,59	☺	☺	☺

Ordering example for the grade WSM23X: WT26-R-ER-AG60 WSM23X

HC = Coated carbide

# External thread turning inserts – full profile, ISO metric 60°

WT

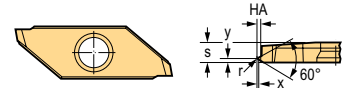

## Indexable inserts

Designation	P mm	s mm	r mm	HA mm	l mm	X mm	Y mm	P	M	S	
								HC	HC	HC	
	WT26-R-ER0.25ISO	0,25	3,18	0,04	0,18	25	0,03	0,28	☺	☺	☺
	WT26-R-ER0.40ISO	0,4	3,18	0,06	0,29	25	0,04	0,38	☺	☺	☺
	WT26-R-ER0.50ISO	0,5	3,18	0,07	0,36	25	0,04	0,38	☺	☺	☺
	WT26-R-ER0.70ISO	0,7	3,18	0,1	0,51	25	0,08	0,38	☺	☺	☺
	WT26-R-ER0.80ISO	0,8	3,18	0,12	0,58	25	0,09	0,38	☺	☺	☺
	WT26-R-ER1.00ISO	1	3,18	0,14	0,72	25	0,11	0,38	☺	☺	☺
	WT26-R-ER1.25ISO	1,25	3,18	0,18	0,9	25	0,14	0,38	☺	☺	☺
	WT26-R-ER1.50ISO	1,5	3,18	0,22	1,08	25	0,16	0,38	☺	☺	☺
	WT26-L-EL0.50ISO	0,5	3,18	0,07	0,36	25	0,04	0,38	☺	☺	☺
	WT26-L-EL0.70ISO	0,7	3,18	0,1	0,51	25	0,08	0,38	☺	☺	☺
	WT26-L-EL0.80ISO	0,8	3,18	0,12	0,58	25	0,09	0,38	☺	☺	☺
	WT26-L-EL1.00ISO	1	3,18	0,14	0,72	25	0,11	0,38	☺	☺	☺
	WT26-L-EL1.25ISO	1,25	3,18	0,18	0,9	25	0,14	0,38	☺	☺	☺
	WT26-L-EL1.50ISO	1,5	3,18	0,22	1,08	25	0,16	0,38	☺	☺	☺

Ordering example for the grade WSM23X: WT26-R-ER0.25ISO WSM23X

HC = Coated carbide

## Semi-finished blanks for special shapes

WT

WT...R...

WT...L...

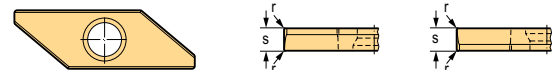

## Cutting inserts

Designation	s mm	r mm	l mm	P	M	S	
				HW	HW	HW	
	WT26-L300N00N	3	0,05	25,6	☺	☺	☺
	WT26-R300N00N	3	0,05	256,6	☺	☺	☺

Ordering example for the grade WMG40: WT26-L300N00N WMG40

HW = Uncoated carbide

**WALTER SELECT**

Optimum indexable insert for → Good = ☺ → Average = ☹ → Poor = ☹ machining conditions

☺ ☹ ☹ / ★ = New addition to the product range

Single-, double- and multi-edged cutting inserts A 409

# Exchangeable head – Grooving and circlip grooves

## WE..-G

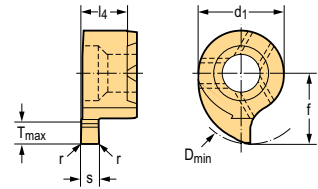

### Exchangeable head

Designation	d <sub>1</sub> mm	s mm	r mm	T <sub>max</sub> mm	D <sub>min</sub> mm	f <sub>1</sub> mm	l <sub>4</sub> mm	f mm	P		M		N		S	
									HC		HC		HC		HC	
									WSM13X	WSM23X	WSM13X	WSM23X	WSM13X	WSM23X	WSM13X	WSM23X
WE05-G07-100R00	5	1		1	7	5,8	3,6	0,01-0,04	☹	☹	☹	☹	☹	☹	☹	☹
WE05-G07-150R00	5	1,5		1	7	5,8	3,6	0,01-0,04	☹	☹	☹	☹	☹	☹	☹	☹
WE05-G08-150R02	5	1,5	0,2	2	7,8	5,2	3,7	0,01-0,04	☹	☹	☹	☹	☹	☹	☹	☹
WE07-G10-073R00	7	0,73		1,2	10	5,8	3,7	0,01-0,04	☹	☹	☹	☹	☹	☹	☹	☹
WE07-G10-083R00	7	0,83		1,3	10	5,8	3,7	0,01-0,04	☹	☹	☹	☹	☹	☹	☹	☹
WE07-G10-093R00	7	0,93		1,5	10	5,8	3,7	0,01-0,04	☹	☹	☹	☹	☹	☹	☹	☹
WE07-G10-100R00	7	1		1,8	10	5,8	3,7	0,01-0,04	☹	☹	☹	☹	☹	☹	☹	☹
WE07-G10-120R00	7	1,2		1,8	10	5,8	3,7	0,01-0,04	☹	☹	☹	☹	☹	☹	☹	☹
WE07-G10-140R00	7	1,4		1,8	10	5,8	3,8	0,01-0,04	☹	☹	☹	☹	☹	☹	☹	☹
WE07-G10-150R00	7	1,5		1,8	10	5,8	3,8	0,01-0,04	☹	☹	☹	☹	☹	☹	☹	☹
WE07-G10-150R02	7	1,5	0,2	1,8	10	5,8	3,9	0,01-0,04	☹	☹	☹	☹	☹	☹	☹	☹
WE07-G10-170R00	7	1,6		1,8	10	5,8	3,8	0,01-0,04	☹	☹	☹	☹	☹	☹	☹	☹
WE07-G10-200R00	7	2		1,8	10	5,8	3,9	0,01-0,04	☹	☹	☹	☹	☹	☹	☹	☹
WE07-G10-200R02	7	2	0,2	1,8	10	5,8	3,9	0,01-0,04	☹	☹	☹	☹	☹	☹	☹	☹
WE07-G10-250R00	7	2,5		1,8	10	5,8	3,9	0,01-0,04	☹	☹	☹	☹	☹	☹	☹	☹
WE07-G10-300R00	7	3		1,8	10	5,8	3,9	0,01-0,04	☹	☹	☹	☹	☹	☹	☹	☹
WE07-G11-100R00	7	1		2,8	11	6,8	3,7	0,01-0,04	☹	☹	☹	☹	☹	☹	☹	☹
WE07-G11-150R00	7	1,5		2,8	11	6,8	3,8	0,01-0,04	☹	☹	☹	☹	☹	☹	☹	☹
WE07-G11-200R00	7	2		2,8	11	6,8	3,9	0,01-0,04	☹	☹	☹	☹	☹	☹	☹	☹
WE07-G11-250R00	7	2,5		2,8	11	6,8	3,9	0,01-0,04	☹	☹	☹	☹	☹	☹	☹	☹
WE07-G11-300R00	7	3		2,8	11	6,8	3,9	0,01-0,04	☹	☹	☹	☹	☹	☹	☹	☹
WE07-G11-318R00	7	3,18		2,8	11	6,8	3,9	0,01-0,04	☹	☹	☹	☹	☹	☹	☹	☹
WE07-G12-100R00	7	1		3,4	12	7,4	3,7	0,01-0,04	☹	☹	☹	☹	☹	☹	☹	☹
WE07-G12-150R00	7	1,5		3,4	12	7,4	3,8	0,01-0,04	☹	☹	☹	☹	☹	☹	☹	☹
WE07-G12-200R00	7	2		3,4	12	7,4	3,9	0,01-0,04	☹	☹	☹	☹	☹	☹	☹	☹
WE09-G14-073R00	9	0,73		1,2	14	9	5,1	0,01-0,04	☹	☹	☹	☹	☹	☹	☹	☹
WE09-G14-083R00	9	0,83		1,3	14	9	5,1	0,01-0,04	☹	☹	☹	☹	☹	☹	☹	☹
WE09-G14-093R00	9	0,93		1,5	14	9	5,1	0,01-0,04	☹	☹	☹	☹	☹	☹	☹	☹
WE09-G14-100R00	9	1		4	14	9	5,1	0,01-0,04	☹	☹	☹	☹	☹	☹	☹	☹
WE09-G14-120R00	9	1,2		4	14	9	5,2	0,01-0,04	☹	☹	☹	☹	☹	☹	☹	☹
WE09-G14-140R00	9	1,4		4	14	9	5,2	0,01-0,04	☹	☹	☹	☹	☹	☹	☹	☹
WE09-G14-150R00	9	1,5		4	14	9	5,2	0,01-0,04	☹	☹	☹	☹	☹	☹	☹	☹
WE09-G14-170R00	9	1,7		4	14	9	5,2	0,01-0,04	☹	☹	☹	☹	☹	☹	☹	☹
WE09-G14-200R00	9	2		4	14	9	5,2	0,01-0,04	☹	☹	☹	☹	☹	☹	☹	☹
WE09-G14-200R02	9	2	0,2	4	14	9	5,2	0,01-0,04	☹	☹	☹	☹	☹	☹	☹	☹
WE09-G14-250R00	9	2,5		4	14	9	5,2	0,01-0,04	☹	☹	☹	☹	☹	☹	☹	☹
WE09-G14-300R00	9	3		4	14	9	5,2	0,01-0,04	☹	☹	☹	☹	☹	☹	☹	☹
WE09-G14-318R02	9	3,18	0,2	4	14	90	5,2	0,01-0,04	☹	☹	☹	☹	☹	☹	☹	☹
WE09-G16-150R00	9	1,5		5,5	16	10,5	4,9	0,01-0,04	☹	☹	☹	☹	☹	☹	☹	☹
WE09-G16-150R02	9	1,5	0,2	4	16	9	5,2	0,01-0,04	☹	☹	☹	☹	☹	☹	☹	☹
WE09-G16-200R00	9	2		5,5	16	10,5	5,1	0,01-0,04	☹	☹	☹	☹	☹	☹	☹	☹
WE09-G16-200R02	9	2	0,2	5,5	16	10,5	5,1	0,01-0,04	☹	☹	☹	☹	☹	☹	☹	☹
WE09-G16-250R00	9	2,5		5,5	16	10,5	5,1	0,01-0,04	☹	☹	☹	☹	☹	☹	☹	☹

Dimensional drawing shows right-hand version.

Ordering example for the grade WSM23X: WE05-G07-100R00 WSM23X

HC = Coated carbide

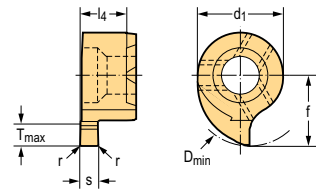

# Exchangeable head – Grooving and circlip grooves

## WE..-G



A2

### Exchangeable head

Designation	d <sub>1</sub> mm	s mm	r mm	T <sub>max</sub> mm	D <sub>min</sub> mm	f <sub>1</sub> mm	l <sub>4</sub> mm	f mm	P		M		N		S	
									HC		HC		HC		HC	
									WSM13X	WSM23X	WSM13X	WSM23X	WSM13X	WSM23X	WSM13X	WSM23X
 WE09-G16-250R02	9	2,5	0,2	5,5	16	10,5	5,1	0,01-0,04	☺	☺	☺	☺	☺	☺	☺	☺
WE09-G16-300R00	9	3		5,5	16	10,5	5,1	0,01-0,04	☺	☺	☺	☺	☺	☺	☺	☺
WE09-G16-300R02	9	3	0,2	5,5	16	10,5	5,1	0,01-0,04	☺	☺	☺	☺	☺	☺	☺	☺
WE09-G17-150R00	9	1,5		6,5	17	11,5	4,9	0,01-0,04	☺	☺	☺	☺	☺	☺	☺	☺
WE09-G17-200R00	9	2		6,5	17	11,5	5,1	0,01-0,04	☺	☺	☺	☺	☺	☺	☺	☺
WE09-G17-250R00	9	2,5		6,5	17	11,5	5,1	0,01-0,04	☺	☺	☺	☺	☺	☺	☺	☺
WE09-G17-300R00	9	3		6,5	17	11,5	5,1	0,01-0,04	☺	☺	☺	☺	☺	☺	☺	☺
 WE05-G07-100L00	5	1		1	7	5,8	3,6	0,01-0,04	☺	☺	☺	☺	☺	☺	☺	☺
WE05-G07-150L00	5	1,5		1	7	5,8	3,6	0,01-0,04	☺	☺	☺	☺	☺	☺	☺	☺
WE05-G08-150L02	5	1,5	0,2	2	7,8	5,2	3,7	0,01-0,04	☺	☺	☺	☺	☺	☺	☺	☺
WE07-G10-073L00	7	0,7		1,2	10	5,8	3,7	0,01-0,04	☺	☺	☺	☺	☺	☺	☺	☺
WE07-G10-083L00	7	0,8		1,3	10	5,8	3,7	0,01-0,04	☺	☺	☺	☺	☺	☺	☺	☺
WE07-G10-100L00	7	1		1,8	10	5,8	3,7	0,01-0,04	☺	☺	☺	☺	☺	☺	☺	☺
WE07-G10-120L00	7	1,2		1,8	10	5,8	3,7	0,01-0,04	☺	☺	☺	☺	☺	☺	☺	☺
WE07-G10-150L00	7	1,5		1,8	10	5,8	3,8	0,01-0,04	☺	☺	☺	☺	☺	☺	☺	☺
WE07-G10-150L02	7	1,5	0,2	1,8	10	5,8	3,9	0,01-0,04	☺	☺	☺	☺	☺	☺	☺	☺
WE07-G10-170L00	7	1,6		1,8	10	5,8	3,8	0,01-0,04	☺	☺	☺	☺	☺	☺	☺	☺
WE07-G10-200L00	7	2		1,8	10	5,8	3,9	0,01-0,04	☺	☺	☺	☺	☺	☺	☺	☺
WE07-G10-200L02	7	2	0,2	1,8	10	5,8	3,9	0,01-0,04	☺	☺	☺	☺	☺	☺	☺	☺
WE07-G10-250L00	7	2,5		1,8	10	5,8	3,9	0,01-0,04	☺	☺	☺	☺	☺	☺	☺	☺
WE07-G10-300L00	7	3		1,8	10	5,8	3,9	0,01-0,04	☺	☺	☺	☺	☺	☺	☺	☺
WE07-G11-100L00	7	1		2,8	11	6,8	3,7	0,01-0,04	☺	☺	☺	☺	☺	☺	☺	☺
WE07-G11-150L00	7	1,5		2,8	11	6,8	3,8	0,01-0,04	☺	☺	☺	☺	☺	☺	☺	☺
WE07-G11-200L00	7	2		2,8	11	6,8	3,9	0,01-0,04	☺	☺	☺	☺	☺	☺	☺	☺
WE07-G11-250L00	7	2,5		2,8	11	6,8	3,9	0,01-0,04	☺	☺	☺	☺	☺	☺	☺	☺
WE07-G11-300L00	7	3		2,8	11	6,8	3,9	0,01-0,04	☺	☺	☺	☺	☺	☺	☺	☺
WE07-G11-318L00	7	3,18		2,8	11	6,8	3,9	0,01-0,04	☺	☺	☺	☺	☺	☺	☺	☺
WE07-G12-100L00	7	1		3,4	12	7,4	3,7	0,01-0,04	☺	☺	☺	☺	☺	☺	☺	☺
WE07-G12-150L00	7	1,5		3,4	12	7,4	3,8	0,01-0,04	☺	☺	☺	☺	☺	☺	☺	☺
WE07-G12-200L00	7	2		3,4	12	7,4	3,9	0,01-0,04	☺	☺	☺	☺	☺	☺	☺	☺
WE09-G14-073L00	9	0,73		1,2	14	9	5,1	0,01-0,04	☺	☺	☺	☺	☺	☺	☺	☺
WE09-G14-083L00	9	0,83		1,3	14	9	5,1	0,01-0,04	☺	☺	☺	☺	☺	☺	☺	☺
WE09-G14-093L00	9	0,93		1,5	14	9	5,1	0,01-0,04	☺	☺	☺	☺	☺	☺	☺	☺
WE09-G14-100L00	9	1		4	14	9	5,1	0,01-0,04	☺	☺	☺	☺	☺	☺	☺	☺
WE09-G14-120L00	9	1,2		4	14	9	5,2	0,01-0,04	☺	☺	☺	☺	☺	☺	☺	☺
WE09-G14-140L00	9	1,4		4	14	9	5,2	0,01-0,04	☺	☺	☺	☺	☺	☺	☺	☺
WE09-G14-150L00	9	1,5		4	14	9	5,2	0,01-0,04	☺	☺	☺	☺	☺	☺	☺	☺
WE09-G14-170L00	9	1,7		4	14	9	5,2	0,01-0,04	☺	☺	☺	☺	☺	☺	☺	☺
WE09-G14-200L00	9	2		4	14	9	5,2	0,01-0,04	☺	☺	☺	☺	☺	☺	☺	☺
WE09-G14-200L02	9	2	0,2	4	14	9	5,2	0,01-0,04	☺	☺	☺	☺	☺	☺	☺	☺
WE09-G14-250L00	9	2,5		4	14	9	5,2	0,01-0,04	☺	☺	☺	☺	☺	☺	☺	☺
WE09-G14-300L00	9	3		4	14	9	5,2	0,01-0,04	☺	☺	☺	☺	☺	☺	☺	☺
WE09-G16-150L00	9	1,5		5,5	16	10,5	4,9	0,01-0,04	☺	☺	☺	☺	☺	☺	☺	☺

Dimensional drawing shows right-hand version.

HC = Coated carbide

Ordering example for the grade WSM23X: WE05-G07-100R00 WSM23X

### WALTER SELECT

Optimum indexable insert for → Good = ☺ → Average = ☹ → Poor = ☹☹ machining conditions

☺ ☹ ☹☹ / \* = New addition to the product range

## Exchangeable head – Grooving and circlip grooves WE..-G

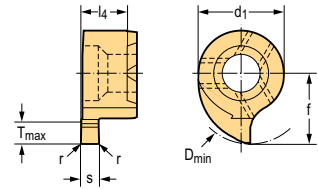

### Exchangeable head

Designation	d <sub>1</sub> mm	s mm	r mm	T <sub>max</sub> mm	D <sub>min</sub> mm	f <sub>1</sub> mm	l <sub>4</sub> mm	f mm	P		M		N		S	
									HC		HC		HC		HC	
									WSM13X	WSM23X	WSM13X	WSM23X	WSM13X	WSM23X	WSM13X	WSM23X
 WE09-G16-150L02	9	1,5	0,2	4	16	9	5,2	0,01-0,04	☹	☹	☹	☹	☹	☹	☹	☹
WE09-G16-200L00	9	2		5,5	16	10,5	5,1	0,01-0,04	☹	☹	☹	☹	☹	☹	☹	☹
WE09-G16-200L02	9	2	0,2	5,5	16	10,5	5,1	0,01-0,04	☹	☹	☹	☹	☹	☹	☹	☹
WE09-G16-250L00	9	2,5		5,5	16	10,5	5,1	0,01-0,04	☹	☹	☹	☹	☹	☹	☹	☹
WE09-G16-250L02	9	2,5	0,2	5,5	16	10,5	5,1	0,01-0,04	☹	☹	☹	☹	☹	☹	☹	☹
WE09-G16-300L00	9	3		5,5	16	10,5	5,1	0,01-0,04	☹	☹	☹	☹	☹	☹	☹	☹
WE09-G16-300L02	9	3	0,2	5,5	16	10,5	5,1	0,01-0,04	☹	☹	☹	☹	☹	☹	☹	☹
WE09-G17-150L00	9	1,5		6,5	17	11,5	4,9	0,01-0,04	☹	☹	☹	☹	☹	☹	☹	☹
WE09-G17-200L00	9	2		6,5	17	11,5	5,1	0,01-0,04	☹	☹	☹	☹	☹	☹	☹	☹
WE09-G17-250L00	9	2,5		6,5	17	11,5	5,1	0,01-0,04	☹	☹	☹	☹	☹	☹	☹	☹
WE09-G17-300L00	9	3		6,5	17	11,5	5,1	0,01-0,04	☹	☹	☹	☹	☹	☹	☹	☹

Dimensional drawing shows right-hand version.

Ordering example for the grade WSM23X: WE05-G07-100R00 WSM23X

HC = Coated carbide

## Exchangeable head – Grooving and copy turning WE..-GR

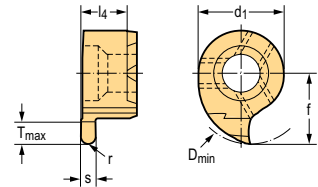

### Exchangeable head

Designation	d <sub>1</sub> mm	s mm	r mm	T <sub>max</sub> mm	D <sub>min</sub> mm	f <sub>1</sub> mm	l <sub>4</sub> mm	f mm	P		M		S	
									HC		HC		HC	
									WSM23X	WSM23X	WSM23X	WSM23X	WSM23X	WSM23X
 WE07-GR10-080R04	7	0,8	0,4	1,8	10	5,8	3,7	0,01-0,04	☹	☹	☹	☹	☹	☹
WE07-GR10-120R06	7	1,23	0,6	1,8	10	5,8	3,7	0,01-0,04	☹	☹	☹	☹	☹	☹
WE07-GR10-180R09	7	1,8	0,9	1,8	10	5,8	3,9	0,01-0,04	☹	☹	☹	☹	☹	☹
WE07-GR10-200R10	7	2	1	1,8	10	5,8	3,9	0,01-0,04	☹	☹	☹	☹	☹	☹
WE09-GR14-080R04	9	0,8	0,4	4	14	9	5,1	0,01-0,04	☹	☹	☹	☹	☹	☹
WE09-GR14-120R06	9	1,2	0,6	4	14	9	5,2	0,01-0,04	☹	☹	☹	☹	☹	☹
WE09-GR14-180R09	9	1,8	0,9	4	14	9	5,2	0,01-0,04	☹	☹	☹	☹	☹	☹
WE09-GR14-200R10	9	2	1	4	14	9	5,2	0,01-0,04	☹	☹	☹	☹	☹	☹
WE09-GR14-220R11	9	2,2	1,1	4	14	9	5,2	0,01-0,04	☹	☹	☹	☹	☹	☹
WE09-GR14-300R15	9	3	1,5	4	14	9	5,2	0,01-0,04	☹	☹	☹	☹	☹	☹

Dimensional drawing shows right-hand version.

Ordering example for the grade WSM23X: WE07-GR10-080R04 WSM23X

HC = Coated carbide



## Exchangeable head – Grooving and copy turning WE..-GR

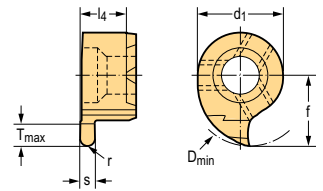

### Exchangeable head

Designation	d <sub>1</sub> mm	s mm	r mm	T <sub>max</sub> mm	D <sub>min</sub> mm	f <sub>1</sub> mm	l <sub>4</sub> mm	f mm	P	M	S
									HC	HC	HC
 WE07-GR10-080L04	7	0,8	0,4	1,8	10	5,8	3,7	0,01-0,04	☞	☞	☞
WE07-GR10-120L06	7	1,23	0,6	1,8	10	5,8	3,7	0,01-0,04	☞	☞	☞
WE07-GR10-180L09	7	1,8	0,9	1,8	10	5,8	3,9	0,01-0,04	☞	☞	☞
WE07-GR10-200L10	7	2	1	1,8	10	5,8	3,9	0,01-0,04	☞	☞	☞
WE09-GR14-080L04	9	0,8	0,4	4	14	9	5,1	0,01-0,04	☞	☞	☞
WE09-GR14-120L06	9	1,2	0,6	4	14	9	5,2	0,01-0,04	☞	☞	☞
WE09-GR14-180L09	9	1,8	0,9	4	14	9	5,2	0,01-0,04	☞	☞	☞
WE09-GR14-200L10	9	2	1	4	14	9	5,2	0,01-0,04	☞	☞	☞
WE09-GR14-220L11	9	2,2	1,1	4	14	9	5,2	0,01-0,04	☞	☞	☞
WE09-GR14-300L15	9	3	1,5	4	14	9	5,2	0,01-0,04	☞	☞	☞

Dimensional drawing shows right-hand version.



Ordering example for the grade WSM23X: WE07-GR10-080R04 WSM23X

HC = Coated carbide

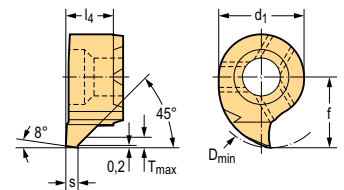
## Exchangeable head – Pre-parting WE..-GP



### Exchangeable head

Designation	d <sub>1</sub> mm	s mm	T <sub>max</sub> mm	D <sub>min</sub> mm	f <sub>1</sub> mm	l <sub>4</sub> mm	f mm	P	M	S
								HC	HC	HC
 WE07-GP10-100R00	7	1	1,5	10	5,8	3,8	0,01-0,04	☞	☞	☞
 WE07-GP10-100L00	7	1	1,5	10	5,8	3,9	0,01-0,04	☞	☞	☞

Dimensional drawing shows right-hand version.

Ordering example for the grade WSM23X: WE07-GP10-100R00 WSM23X



HC = Coated carbide

## Exchangeable head – Axial grooving

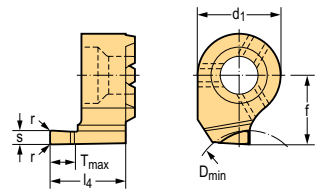
### WE..-A



#### Exchangeable head

Designation	d <sub>1</sub> mm	s mm	r mm	T <sub>max</sub> mm	D <sub>min</sub> mm	f <sub>1</sub> mm	l <sub>4</sub> mm	f mm	P	M	S
									HC	HC	HC
 WE09-A12-100R00	9	1		1,5	12	6	8,3	0,01-0,04	WSM23X	WSM23X	WSM23X
WE09-A12-150R02	9	1,5	0,2	2,5	12	6	8,3	0,01-0,04	WSM23X	WSM23X	WSM23X
WE09-A12-200R02	9	2	0,2	5	12	6	10,3	0,01-0,04	WSM23X	WSM23X	WSM23X
WE09-A12-250R02	9	2,5	0,2	5	12	6	10,3	0,01-0,04	WSM23X	WSM23X	WSM23X
WE09-A12-300R02	9	3	0,2	5	12	6	10,3	0,01-0,04	WSM23X	WSM23X	WSM23X
 WE09-A12-100L00	9	1		1,5	12	6	8,3	0,01-0,04	WSM23X	WSM23X	WSM23X
WE09-A12-150L02	9	1,5	0,2	2,5	12	6	8,3	0,01-0,04	WSM23X	WSM23X	WSM23X
WE09-A12-200L02	9	2	0,2	5	12	6	10,3	0,01-0,04	WSM23X	WSM23X	WSM23X
WE09-A12-250L02	9	2,5	0,2	5	12	6	10,3	0,01-0,04	WSM23X	WSM23X	WSM23X
WE09-A12-300L02	9	3	0,2	5	12	6	10,3	0,01-0,04	WSM23X	WSM23X	WSM23X

Dimensional drawing shows right-hand version.

Ordering example for the grade WSM23X: WE09-A12-100R00 WSM23X



HC = Coated carbide

## Exchangeable head – Axial grooving – Contra

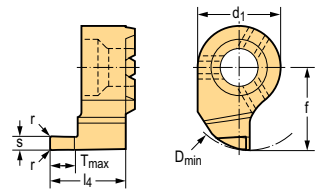
### WE..-AC



#### Exchangeable head

Designation	d <sub>1</sub> mm	s mm	r mm	T <sub>max</sub> mm	D <sub>min</sub> mm	f <sub>1</sub> mm	l <sub>4</sub> mm	f mm	P	M	S
									HC	HC	HC
 WE09-AC14-100R00	9	1		1,5	14	9	8,3	0,01-0,04	WSM23X	WSM23X	WSM23X
WE09-AC14-150R02	9	1,5	0,2	2,5	14	9	8,3	0,01-0,04	WSM23X	WSM23X	WSM23X
WE09-AC14-200R02	9	2	0,2	5	14	9	10,3	0,01-0,04	WSM23X	WSM23X	WSM23X
WE09-AC14-250R02	9	2,5	0,2	5	14	9	10,3	0,01-0,04	WSM23X	WSM23X	WSM23X
WE09-AC14-300R02	9	3	0,2	5	14	9	10,3	0,01-0,04	WSM23X	WSM23X	WSM23X
 WE09-AC14-100L00	9	1		1,5	14	9	8,3	0,01-0,04	WSM23X	WSM23X	WSM23X
WE09-AC14-150L02	9	1,5	0,2	2,5	14	9	8,3	0,01-0,04	WSM23X	WSM23X	WSM23X
WE09-AC14-200L02	9	2	0,2	5	14	9	10,3	0,01-0,04	WSM23X	WSM23X	WSM23X
WE09-AC14-250L02	9	2,5	0,2	5	14	9	10,3	0,01-0,04	WSM23X	WSM23X	WSM23X
WE09-AC14-300L02	9	3	0,2	5	14	9	10,3	0,01-0,04	WSM23X	WSM23X	WSM23X

Dimensional drawing shows right-hand version.

Ordering example for the grade WSM23X: WE09-AC14-100R00 WSM23X

HC = Coated carbide

## Exchangeable head – Axial grooving full radius WE..-AR

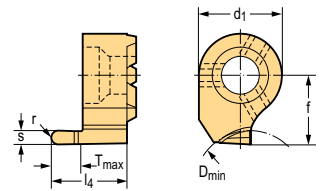

### Exchangeable head

Designation	d <sub>1</sub> mm	s mm	r mm	T <sub>max</sub> mm	D <sub>min</sub> mm	f <sub>1</sub> mm	l <sub>4</sub> mm	f mm	P	M	S
									HC	HC	HC
 WE09-AR12-150R07 WE09-AR12-200R10 WE09-AR12-300R15	9	1,5	0,8	2,5	12	6	8,3	0,01-0,04	WSM23X	WSM23X	WSM23X
	9	2	1	5	12	6	10,3	0,01-0,04	WSM23X	WSM23X	WSM23X
	9	3	1,5	5	12	6	10,3	0,01-0,04	WSM23X	WSM23X	WSM23X
 WE09-AR12-150L07 WE09-AR12-200L10 WE09-AR12-300L15	9	1,5	0,8	2,5	12	6	8,3	0,01-0,04	WSM23X	WSM23X	WSM23X
	9	2	1	5	12	6	10,3	0,01-0,04	WSM23X	WSM23X	WSM23X
	9	3	1,5	5	12	6	10,3	0,01-0,04	WSM23X	WSM23X	WSM23X

Dimensional drawing shows right-hand version.  
Ordering example for the grade WSM23X: WE09-AR12-150R07 WSM23X

HC = Coated carbide

## Exchangeable head – Axial grooving full radius – Contra WE..-AD

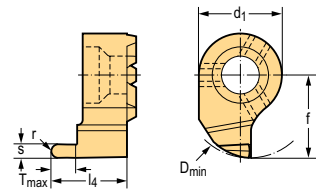

### Exchangeable head

Designation	d <sub>1</sub> mm	s mm	r mm	T <sub>max</sub> mm	D <sub>min</sub> mm	f <sub>1</sub> mm	l <sub>4</sub> mm	f mm	P	M	S
									HC	HC	HC
 WE09-AD14-150R07 WE09-AD14-200R10 WE09-AD14-300R15	9	1,5	0,8	2,5	14	9	8,3	0,01-0,04	WSM23X	WSM23X	WSM23X
	9	2	1	5	14	9	10,3	0,01-0,04	WSM23X	WSM23X	WSM23X
	9	3	1,5	5	14	9	10,3	0,01-0,04	WSM23X	WSM23X	WSM23X
 WE09-AD14-150L07 WE09-AD14-200L10 WE09-AD14-300L15	9	1,5	0,8	2,5	14	9	8,3	0,01-0,04	WSM23X	WSM23X	WSM23X
	9	2	1	5	14	9	10,3	0,01-0,04	WSM23X	WSM23X	WSM23X
	9	3	1,5	5	14	9	10,3	0,01-0,04	WSM23X	WSM23X	WSM23X

Dimensional drawing shows right-hand version.  
Ordering example for the grade WSM23X: WE09-AD14-150R07 WSM23X

HC = Coated carbide

**WALTER SELECT** Optimum indexable insert for → Good = ☺ → Average = ☹ → Poor = ☹ machining conditions



☺ ☹ ☹ / \* = New addition to the product range

Single-edged interchangeable heads A 415

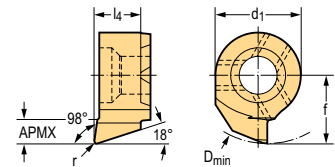
## Exchangeable head – Turning WE..-T



### Exchangeable head

Designation	d <sub>1</sub> mm	r mm	D <sub>min</sub> mm	APMX mm	f mm	l <sub>4</sub> mm	l <sub>20</sub> mm	f mm	P	M	S
									HC	HC	HC
 WE05-T07-098R02 WE07-T10-098R02	5	0,2	7	0,3	4,15	3,6	3,6	0,02–0,10	WSM23X	WSM23X	WSM23X
	7	0,2	10	0,3	5,6	3,8	3,8	0,02–0,10	WSM23X	WSM23X	WSM23X
 WE05-T07-098L02 WE07-T10-098L02	5	0,2	7	0,3	4,15	3,6	3,6	0,02–0,10	WSM23X	WSM23X	WSM23X
	7	0,2	10	0,3	5,6	3,8	3,8	0,02–0,10	WSM23X	WSM23X	WSM23X

Ordering example for the grade WSM23X: WE05-T07-098R02 WSM23X

HC = Coated carbide

## Exchangeable head – Turning WE..-T

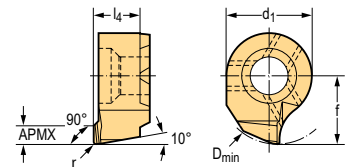

### Exchangeable head

Designation	d <sub>1</sub> mm	r mm	D <sub>min</sub> mm	APMX mm	f mm	l <sub>4</sub> mm	l <sub>20</sub> mm	f mm	P	M	S
									HC	HC	HC
 WE07-T10X090R02 WE07-T10X090L02	7	0,2	10	0,3	5,6	3,8	3,8	0,02–0,10	WSM23X	WSM23X	WSM23X
	7	0,2	10	0,3	5,6	3,8	3,8	0,02–0,10	WSM23X	WSM23X	WSM23X



Ordering example for the grade WSM23X: WE07-T10X090R02 WSM23X

HC = Coated carbide

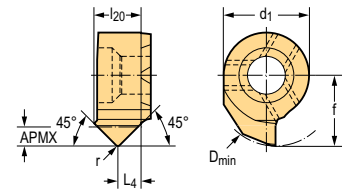
## Exchangeable head – Turning and chamfering WE..-T



### Exchangeable head

Designation	d <sub>1</sub> mm	r mm	D <sub>min</sub> mm	APMX mm	f mm	l <sub>4</sub> mm	l <sub>20</sub> mm	f mm	P	M	S
									HC	HC	HC
 WE07-T10-045R02	7	0.2	10	1.5	5.8	1.9	3.9	0.02-0.10	WSM23X *	WSM23X *	WSM23X *
 WE07-T10-045L02	7	0.2	10	1.5	5.8	1.9	3.9	0.02-0.10	WSM23X *	WSM23X *	WSM23X *



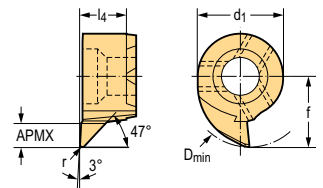

Ordering example for the grade WSM23X: WE07-T10-045R02 WSM23X

HC = Coated carbide

## Exchangeable head – Copy turning WE..-C



### Exchangeable head

Designation	d <sub>1</sub> mm	r mm	D <sub>min</sub> mm	APMX mm	f mm	l <sub>4</sub> mm	f mm	P	M	S
								HC	HC	HC
 WE05-C07-093R02	5	0.2	7	0.3	4.15	3.4	0.02-0.10	WSM23X *	WSM23X *	WSM23X *
 WE07-C10-093R02	7	0.2	10	0.3	5.8	3.8	0.02-0.10	WSM23X *	WSM23X *	WSM23X *
 WE05-C07-093L02	5	0.2	7	0.3	4.15	3.4	0.02-0.10	WSM23X *	WSM23X *	WSM23X *
 WE07-C10-093L02	7	0.2	10	0.3	5.8	3.8	0.02-0.10	WSM23X *	WSM23X *	WSM23X *



Ordering example for the grade WSM23X: WE05-C07-093R02 WSM23X

HC = Coated carbide

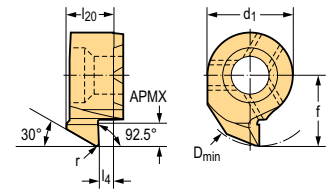
## Exchangeable head – Backward turning WE..-B



### Exchangeable head

Designation	d <sub>1</sub> mm	r mm	D <sub>min</sub> mm	APMX mm	f mm	l <sub>4</sub> mm	l <sub>20</sub> mm	f mm	P	M	S
									HC	HC	HC
 WE07-B10-093R02	7	0,2	10	0,3	5,8	1,2	4	0,02-0,10	WSM23X	WSM23X	WSM23X
 WE07-B10-093L02	7	0,2	10	0,3	5,8	1,2	4	0,02-0,10	WSM23X	WSM23X	WSM23X

Ordering example for the grade WSM23X: WE07-B10-093R02 WSM23X

HC = Coated carbide

## Exchangeable head – 60° partial profile WE..-I

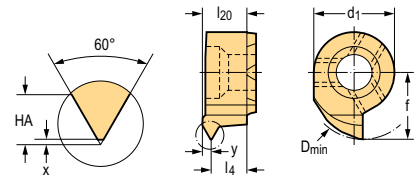

### Exchangeable head

Designation	P mm	P threads per inch in	d <sub>1</sub> mm	l <sub>4</sub> mm	D <sub>min</sub> mm	l <sub>4</sub> mm	f mm	HA mm	X mm	P	M	S
										HC	HC	HC
 WE05-IR07-60050	0,5-0,8	17-15	5	3,8	7	3,8	4,15	0,48	0,05	WSM23X	WSM23X	WSM23X
WE05-IR07-60100	1-1,3	25-20	5	3,8	7	2,6	3,8	0,8	0,1	WSM23X	WSM23X	WSM23X
WE05-IR07-60150	1,5-1,8	51-34	5	3,8	7	2,4	4,15	1,11	0,16	WSM23X	WSM23X	WSM23X
WE07-IR10-60050	0,5-0,8	51-34	7	3,8	10	3,3	5,8	0,49	0,06	WSM23X	WSM23X	WSM23X
WE07-IR10-60100	1-1,3	25-20	7	3,8	10	3,1	5,8	1	0,1	WSM23X	WSM23X	WSM23X
WE07-IR10-60150	1,5-1,8	17-15	7	3,8	10	1,9	5,8	1,2	0,16	WSM23X	WSM23X	WSM23X
WE07-IR10-60200	2-2,5	13-10	7	3,8	10	2,7	5,8	1,82	0,22	WSM23X	WSM23X	WSM23X
WE07-IR10-60250	2,5-3	10-8	7	3,8	10	2,5	5,8	2,17	0,27	WSM23X	WSM23X	WSM23X

Ordering example for the grade WSM23X: WE05-IR07-60050 WSM23X



HC = Coated carbide

## Exchangeable head – Full profile, ISO metric 60°

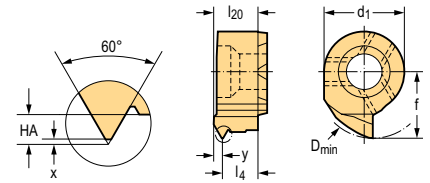
### WE..-I



### Exchangeable head

Designation	P mm	d <sub>1</sub> mm	l <sub>4</sub> mm	D <sub>min</sub> mm	l <sub>4</sub> mm	f mm	HA mm	X mm	P	M	S
									HC	HC	HC
 WE07-IR10-ISO050 WE07-IR10-ISO100 WE07-IR10-ISO150 WE07-IR10-ISO175 WE07-IR10-ISO200 WE07-IR10-ISO250	0,5	7	3,8	10	3,3	5,8	0,27	0,05	WSM23X	WSM23X	WSM23X
	1	7	3,8	10	3,1	5,8	0,65	0,11	WSM23X	WSM23X	WSM23X
	1,5	7	3,8	10	2,9	5,8	0,81	0,16	WSM23X	WSM23X	WSM23X
	1,75	7	3,8	10	2,8	5,8	0,95	0,19	WSM23X	WSM23X	WSM23X
	2	7	3,8	10	2,7	5,8	1,08	0,22	WSM23X	WSM23X	WSM23X
	21,5	7	3,8	10	2,4	5,8	1,35	0,27	WSM23X	WSM23X	WSM23X
 WE07-IL10-ISO050 WE07-IL10-ISO100 WE07-IL10-ISO150 WE07-IL10-ISO175 WE07-IL10-ISO200 WE07-IL10-ISO250	0,5	7	3,8	10	3,3	5,8	0,27	0,05	WSM23X	WSM23X	WSM23X
	1	7	3,8	10	3,1	5,8	0,54	0,11	WSM23X	WSM23X	WSM23X
	1,5	7	3,8	10	2,9	5,8	0,81	0,16	WSM23X	WSM23X	WSM23X
	1,75	7	3,8	10	2,8	5,8	1,57	0,17	WSM23X	WSM23X	WSM23X
	2	7	3,8	10	2,7	5,8	1,08	0,22	WSM23X	WSM23X	WSM23X
	21,5	7	3,8	10	2,4	5,8	1,35	0,27	WSM23X	WSM23X	WSM23X

HC = Coated carbide

Ordering example for the grade WSM23X: WE07-IR10-ISO050 WSM23X

## Exchangeable head – Full profile, American UN 60°

### WE..-I

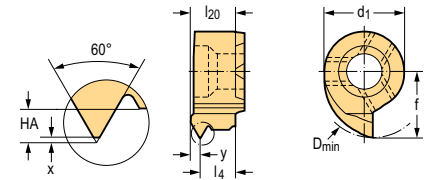

### Exchangeable head

Designation	P threads per inch	d <sub>1</sub> mm	l <sub>4</sub> mm	D <sub>min</sub> mm	l <sub>4</sub> mm	f mm	HA mm	X mm	P	M	S
									HC	HC	HC
 WE07-IR10-UN14 WE07-IR10-UN16 WE07-IR10-UN18 WE07-IR10-UN20 WE07-IR10-UN24 WE07-IR10-UN28	14	7	3,9	10	3,1	5,8	1,17	0,19	WSM23X	WSM23X	WSM23X
	16	7	3,9	10	3	5,8	1,02	0,16	WSM23X	WSM23X	WSM23X
	18	7	3,9	10	3,1	5,8	0,91	0,15	WSM23X	WSM23X	WSM23X
	20	7	3,9	10	3,1	5,8	0,81	0,13	WSM23X	WSM23X	WSM23X
	24	7	3,9	10	3,2	5,8	0,68	0,11	WSM23X	WSM23X	WSM23X
	28	7	3,9	10	3,3	5,8	0,59	0,1	WSM23X	WSM23X	WSM23X

HC = Coated carbide

Ordering example for the grade WSM23X: WE07-IR10-UN14 WSM23X

## Exchangeable head – full profile, Whitworth 55°

WE..-I

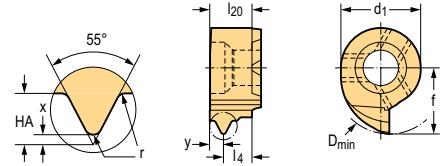

## Exchangeable head

Designation	P threads per inch	r mm	d <sub>1</sub> mm	l <sub>4</sub> mm	D <sub>min</sub> mm	l <sub>4</sub> mm	f mm	HA mm	X mm	P	M	S
										HC	HC	HC
 WE07-IR10-W11 WE07-IR10-W14 WE07-IR10-W19	11	0,31	7	3,8	10	2,2	5,8	1,84	0,36	WSM23X	WSM23X	WSM23X
	14	0,24	7	3,8	10	2,5	5,8	1,44	0,28	HC	HC	HC
	19	0,18	7	3,8	10	2,7	5,8	1,06	0,21	HC	HC	HC

HC = Coated carbide

Ordering example for the grade WSM23X: WE07-IR10-W11 WSM23X



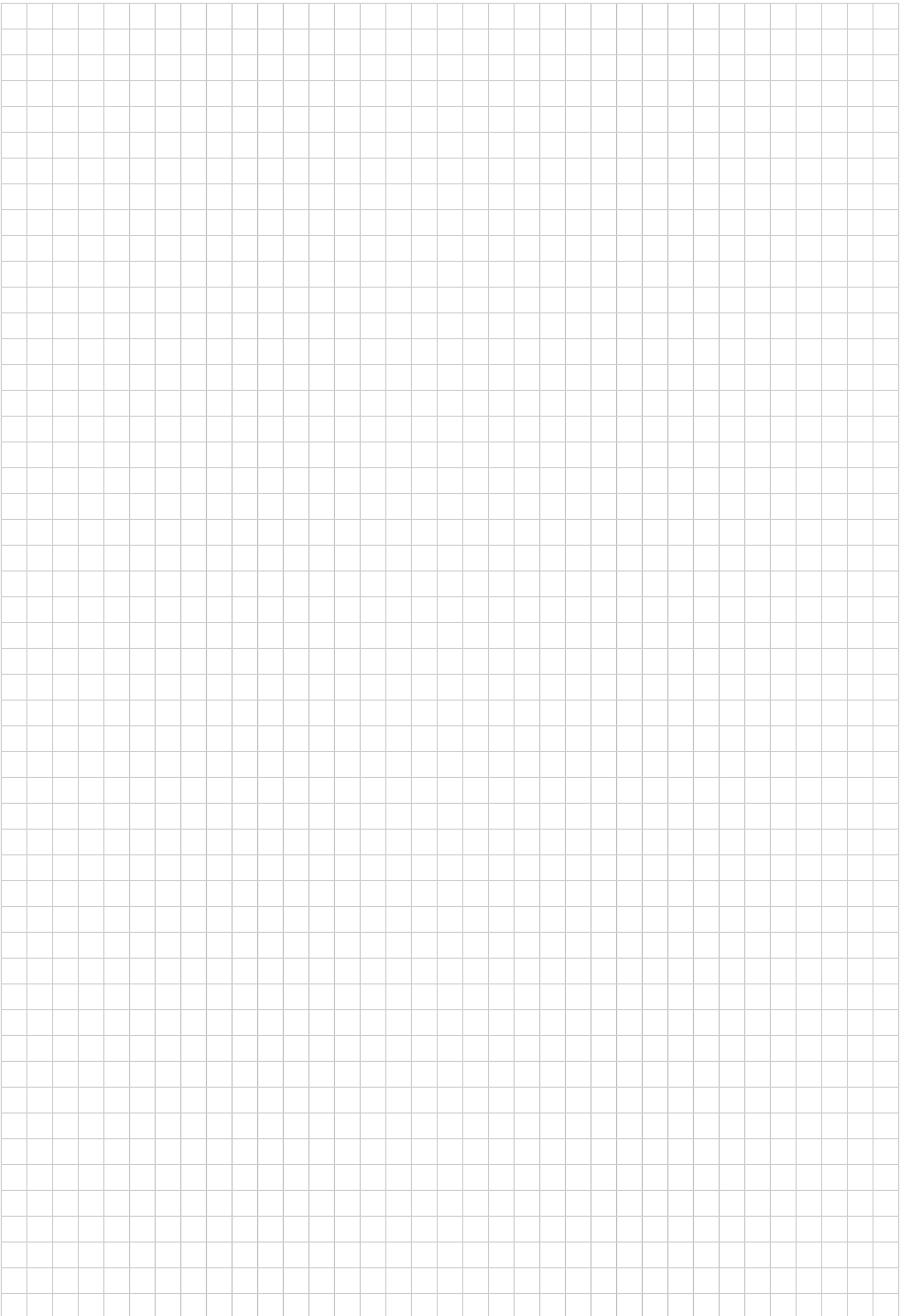

## Shank tools/parting blades

System



Machining

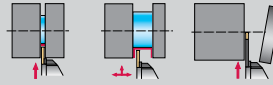

G3011



G3011...-P



G3021...-P

Designation

Insert width $s$ [mm]	0,5–3,25	0,5–5,65	0,5–5,65
Cutting depth $T_{max}$ [mm]	6	6	6
Coolant supply	External	Precision cooling	Precision cooling
Shank size $h$ [mm]	10–25	12–25	20–25
Shank size $h$ [Inch]		0,500–1,000	1,000
Page in catalogue	A 438	A 440	A 444

QR code



G3011



G3011-P



G3021-P

[www.walter-tools.com/woc/](http://www.walter-tools.com/woc/)

System



Machining

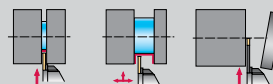

G3051...-P



G4014



G4014...-P

Designation

Insert width $s$ [mm]	0,5–3,25	1–3	2–3
Cutting depth $T_{max}$ [mm]	6	17,5	17,5
Coolant supply	Precision cooling	External	Precision cooling
Shank size $h$ [mm]	12–25	10–20	12–20
Shank size $h$ [Inch]	0,625–1,000	0,500–0,625	0,500–0,750
Page in catalogue	A 446	A 451	A 451

QR code



G3051-P



G4014



G4014-P

[www.walter-tools.com/woc/](http://www.walter-tools.com/woc/)

## Shank tools/parting blades

System



Machining

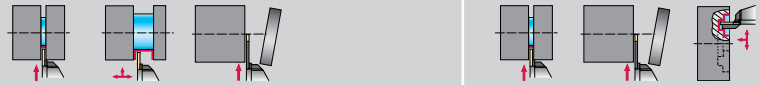

G4011



G4011...-P



G4511

Designation

Insert width s [mm]	2-4	2-4	2-6
Cutting depth $T_{max}$ [mm]	17	17	5
Coolant supply	External	Precision cooling	External
Shank size h [mm]	16-25	20-25	12-25
Shank size h [Inch]	0,750-1,000	1,000	
Page in catalogue	A 458	A 458	A 465

QR code



G4011



G4011-P



G4511

[www.walter-tools.com/woc/](http://www.walter-tools.com/woc/)

System



Machining

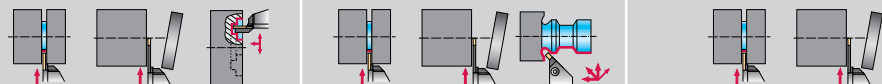

G4521



G4551



G4041

Designation

Insert width s [mm]	2-6	2-6	1,5-3
Cutting depth $T_{max}$ [mm]	5	5	21
Coolant supply	External	External	External
Shank size h [mm]	20-25	20-25	26-32
Shank size h [Inch]			
Page in catalogue	A 466	A 467	A 470

QR code



G4521



G4551



G4041

[www.walter-tools.com/woc/](http://www.walter-tools.com/woc/)

## Shank tools/parting blades

System



Machining

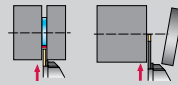

G4041...-P



G4041...C



G4041...C-P

Designation

Insert width s [mm]	2-3	1,5-3	2-3
Cutting depth $T_{max}$ [mm]	21	21	21
Coolant supply	Precision cooling	External	Precision cooling
Shank size h [mm]	26-32	26-32	26-32
Shank size h [Inch]			
Page in catalogue	A 470	A 472	A 472

QR code

[www.walter-tools.com/woc/G4041-P](http://www.walter-tools.com/woc/G4041-P)

[www.walter-tools.com/woc/G4041-C](http://www.walter-tools.com/woc/G4041-C)

[www.walter-tools.com/woc/G4041-C-P](http://www.walter-tools.com/woc/G4041-C-P)

System



Machining

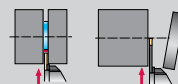

G4042...N



G4042...N...-P



G4634-P

Designation

Insert width s [mm]	1,5-4	3	2-3
Cutting depth $T_{max}$ [mm]	40	40	16
Coolant supply	External	Precision cooling	Precision cooling
Shank size h [mm]	26-32	26-32	E33
Shank size h [Inch]			
Page in catalogue	A 468	A 468	A 476

QR code

[www.walter-tools.com/woc/G4042-N](http://www.walter-tools.com/woc/G4042-N)

[www.walter-tools.com/woc/G4042-N-P](http://www.walter-tools.com/woc/G4042-N-P)

[www.walter-tools.com/woc/G4634-P](http://www.walter-tools.com/woc/G4634-P)

## Shank tools/parting blades

System



Machining

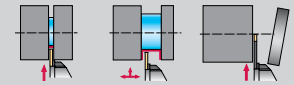
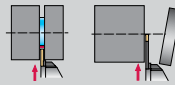

NEW



Designation

G4635

G4635-P

G5011

Insert width  $s$  [mm]

1,5–3

2–2,5

3–6

Cutting depth  $T_{max}$  [mm]

17

16

21

Coolant supply

External

Precision cooling

External

Shank size  $h$  [mm]

E30

E33

16–25

Shank size  $h$  [Inch]

0,625–1,000

Page in catalogue

A 474

A 475

A 479

QR code

[www.walter-tools.com/woc/](http://www.walter-tools.com/woc/)

G4635

G4635-P

G5011

System



Machining

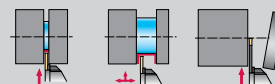

NEW



Designation

G5011...-P

G1011

G1011...-P

Insert width  $s$  [mm]

2,5–6

2–8

2–8

Cutting depth  $T_{max}$  [mm]

21

38

33

Coolant supply

Precision cooling

External

Precision cooling

Shank size  $h$  [mm]

16–25

16–32

16–32

Shank size  $h$  [Inch]

0,750–1,000

0,625–1,500

0,750–1,000

Page in catalogue

A 477

A 488

A 490

QR code

[www.walter-tools.com/woc/](http://www.walter-tools.com/woc/)

G5011-P

G1011

G1011-P

## Shank tools/parting blades

System



Machining

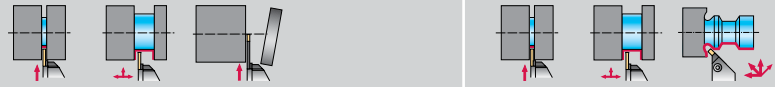

Designation

**G1511**
**G1521**
**G1551**

 Insert width  $s$  [mm]

2–6

2–6

2–6

 Cutting depth  $T_{max}$  [mm]

6

6

6

Coolant supply

External

External

External

 Shank size  $h$  [mm]

20–25

20–25

20–25

 Shank size  $h$  [Inch]

0,750–1,000

0,750–1,000

0,750–1,000

Page in catalogue

A 501

A 503

A 505

QR code

[www.walter-tools.com/woc/](http://www.walter-tools.com/woc/)

G1511

G1521

G1551

System



Machining

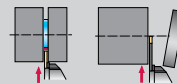

Designation

**G1041**
**G1041...-P**
**G1041...C**

 Insert width  $s$  [mm]

2–4

3–4

2–4

 Cutting depth  $T_{max}$  [mm]

32

33

32

Coolant supply

External

Precision cooling

External

 Shank size  $h$  [mm]

26–32

26–32

26–32

 Shank size  $h$  [Inch]

1,024–1,260

1,024–1,260

1,024–1,260

Page in catalogue

A 508

A 508

A 508

QR code

[www.walter-tools.com/woc/](http://www.walter-tools.com/woc/)

G1041

G1041-P

G1041-C

## Shank tools/parting blades

System



Machining

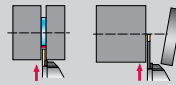

Designation

G1041...C-P

G1042

XLCFN

Insert width s [mm]

2-4

2-6

3-6

Cutting depth  $T_{max}$  [mm]

33

60

21

Coolant supply

Precision cooling

External

External

Shank size h [mm]

26-32

26-32

32

Shank size h [Inch]

A 508

A 507

A 512

Page in catalogue



QR code

www.walter-tools.com/woc/

G1041-C-P

G1042

XLCFN

System



Machining

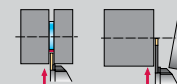
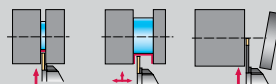

Designation

MSS...E...

G1332

G1634-P

Insert width s [mm]

0,6-8

3

2-4

Cutting depth  $T_{max}$  [mm]

21

15

33

Coolant supply

External

EXT

Precision cooling

Shank size h [mm]

E20-E32

EXT

E33-E43

Shank size h [Inch]

A 551

A 515

A 513

Page in catalogue



QR code

www.walter-tools.com/woc/

MSS-E

G1332

G1634-P

## Shank tools/parting blades

System



Machining



G1111



G1111...-P



MSS...E...A

Designation

Insert width $s$ [mm]	3–6	5	3–6
Cutting depth $T_{max}$ [mm]	25	33	15
Coolant supply	External	Precision cooling	External
Shank size $h$ [mm]	25	25	E20–E32
Shank size $h$ [Inch]	1,000		
Page in catalogue	A 517	A 517	A 551

QR code

[www.walter-tools.com/woc/G1111](http://www.walter-tools.com/woc/G1111)

[www.walter-tools.com/woc/G1111-P](http://www.walter-tools.com/woc/G1111-P)

[www.walter-tools.com/woc/MSS-E-A](http://www.walter-tools.com/woc/MSS-E-A)

System



Machining

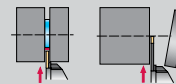

MSS...E...C



G2012



G2012...-P

Designation

Insert width $s$ [mm]	4–6	1,5–3	2–6
Cutting depth $T_{max}$ [mm]	25	33	40
Coolant supply	External	External	Internal
Shank size $h$ [mm]	E25	20–25	12–25
Shank size $h$ [Inch]		0,750–1,000	0,500–1,000
Page in catalogue	A 551	A 526	A 527

QR code

[www.walter-tools.com/woc/MSS-E-C](http://www.walter-tools.com/woc/MSS-E-C)

[www.walter-tools.com/woc/G2012](http://www.walter-tools.com/woc/G2012)

[www.walter-tools.com/woc/G2012-P](http://www.walter-tools.com/woc/G2012-P)



## Shank tools/parting blades

System



Machining

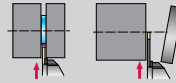

G2042...R/L



G2042...R/L...-P



G2042...R/L...C

Designation

Insert width s [mm]	1,5-4	2-4	4
Cutting depth $T_{max}$ [mm]	33	33	33
Coolant supply	External	Precision cooling	External
Shank size h [mm]	26-32	26-32	32
Shank size h [Inch]			
Page in catalogue	A 531	A 531	A 531

QR code

[www.walter-tools.com/woc/](http://www.walter-tools.com/woc/)

G2042-R-L

G2042-R-L-P

G2042-R-L-C

System



Machining

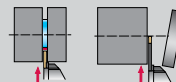

G2042...R/L...C-P



G2042...N



G2042...N...-P

Designation

Insert width s [mm]	2-4	2-6	3-10
Cutting depth $T_{max}$ [mm]	33	80	100
Coolant supply	Precision cooling	External	Precision cooling
Shank size h [mm]	26-32	26-46	26-52
Shank size h [Inch]			
Page in catalogue	A 531	A 531	A 531

QR code

[www.walter-tools.com/woc/](http://www.walter-tools.com/woc/)

G2042-R-L-C-P

G2042-N

G2042-N-P

## Shank tools/parting blades

System



Machining

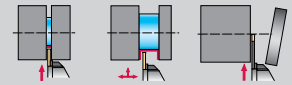
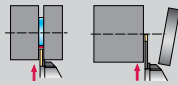

Designation

G2632-E...R/L...-SX

G2016...-P

MSS-...00

 Insert width  $s$  [mm]

2–8

12–19

 Cutting depth  $T_{max}$  [mm]

45

41

Coolant supply

External

Precision cooling

External

 Shank size  $h$  [mm]

E20–E32

25–32

20–32

 Shank size  $h$  [Inch]

E20–E32

25–32

0,750–1,250

Page in catalogue

A 557

A 543

A 538

QR code

[www.walter-tools.com/woc/](http://www.walter-tools.com/woc/)

G2632

G2016-P

MSS-00

System

Machining

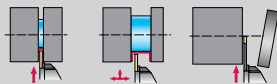

Designation

MSS-...90

G2661...-P

SBN

 Insert width  $s$  [mm]

 Cutting depth  $T_{max}$  [mm]

Coolant supply

External

Internal

External

 Shank size  $h$  [mm]

20–32

16–40

20–40

 Shank size  $h$  [Inch]

0,750–1,250

0,750–1,500

0,750–1,250

Page in catalogue

A 538

A 546

A 129

QR code

[www.walter-tools.com/woc/](http://www.walter-tools.com/woc/)

MSS-90

G2661-P

SBN

## Shank tools/parting blades

System



Machining

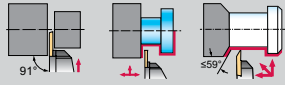

Designation

W2011

Insert width s [mm]

0,5–3

Cutting depth  $T_{max}$  [mm]

8,5

Coolant supply

External

Shank size h [mm]

10–16

Shank size h [Inch]

0,500–0,625

Page in catalogue

QR code

[www.walter-tools.com/woc/](http://www.walter-tools.com/woc/)

W2011

## Walter Capto™ groove turning holders

System	MX..	DX..	GX..
Machining			
Designation	G3011-C...-P	G4011-C...-P	G1011-C...-P
Insert width s [mm]	0,5–5,65	2	3–5
Cutting depth T <sub>max</sub> [mm]	6	17	21
Coolant supply	Precision cooling	Precision cooling	Precision cooling
Walter Capto™ size	C3–C6	C3–C4	C3–C6
Page in catalogue	A 548	A 549	A 550
QR code			
<a href="http://www.walter-tools.com/woc/">www.walter-tools.com/woc/</a>	G3011-C-P	G4011-C-P	G1011-C-P

System	GX..		
Machining			
Designation	MSS...E...	MSS...E...A	MSS...E...C
Insert width s [mm]	0,6–8	3–6	4–6
Cutting depth T <sub>max</sub> [mm]	21	15	25
Coolant supply	External	External	External
Walter Capto™ size	E20–E32	E20–E32	E25
Page in catalogue	A 551	A 551	A 551
QR code			
<a href="http://www.walter-tools.com/woc/">www.walter-tools.com/woc/</a>	MSS-E	MSS-E-A	MSS-E-C

## Walter Capto™ groove turning holders

System



Machining

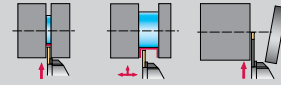
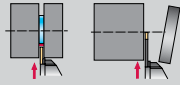

Designation

G2632-E...R/L...-SX

C...-MSS

C...-MSS...90

Insert width  $s$  [mm]

2-8

Cutting depth  $T_{max}$  [mm]

45

Coolant supply

External

Internal

Internal

Walter Capto™ size

E20-E32

C3-C6

C4-C6

Page in catalogue

A 557

A 555

A 555

QR code

[www.walter-tools.com/woc/](http://www.walter-tools.com/woc/)

G2632

C-MSS

C-MSS-90

## Boring bars – Internal grooving

System



Machining

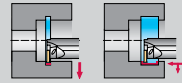

Designation

G3221...-P

G4221...-P

I12

 Insert width  $s$  [mm]

0,5–3,25

2–4

2–2,5

 Cutting depth  $T_{max}$  [mm]

4

10

3

Coolant supply

Precision cooling

Precision cooling

External

 Boring bar  $\varnothing d_1$  [mm]

32

25–32

16

 Boring bar  $\varnothing d_1$  [inch]

0,959–1,250

Page in catalogue

A 558

A 559

A 561

QR code

[www.walter-tools.com/woc/](http://www.walter-tools.com/woc/)
[G3221-P](http://www.walter-tools.com/woc/G3221-P)
[G4221-P](http://www.walter-tools.com/woc/G4221-P)
[I12](http://www.walter-tools.com/woc/I12)

System



Machining

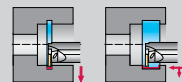

Designation

G1221...-P

MSS...I...

MSS...I...90-1.5

 Insert width  $s$  [mm]

2–6

0,6–6

 Cutting depth  $T_{max}$  [mm]

12

19

Coolant supply

Precision cooling

External

Internal

 Boring bar  $\varnothing d_1$  [mm]

16–40

116–140

20–40

 Boring bar  $\varnothing d_1$  [inch]

0,602–1,500

0,039–1,500

Page in catalogue

A 562

A 568

A 564

QR code

[www.walter-tools.com/woc/](http://www.walter-tools.com/woc/)
[G1221-P](http://www.walter-tools.com/woc/G1221-P)
[MSS-I](http://www.walter-tools.com/woc/MSS-I)
[MSS-I-1-5](http://www.walter-tools.com/woc/MSS-I-1-5)

## Boring bars – Internal grooving

### System

#### Machining

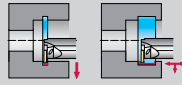

#### Designation

MSS...I...90-2.5

Insert width  $s$  [mm]

Cutting depth  $T_{max}$  [mm]

Coolant supply

Internal

Boring bar  $\emptyset d_1$  [mm]

20–50

Boring bar  $\emptyset d_1$  [inch]

0,039–2,000

Page in catalogue

A 564

#### QR code



[www.walter-tools.com/woc/](http://www.walter-tools.com/woc/)

MSS-I-2-5

NEW



Boring bar for exchangeable head

NEW





Boring bar for exchangeable head

NEW



Boring bar for exchangeable head – Axial grooving

Designation	W3270-A	W3270-E	W3271-E
Machine-side	Parallel shank with clamping surface	Parallel shank with clamping surface	Parallel shank with clamping surface
Tool-side	05 - 09	05 - 09	09F(R)
Page in catalogue	A 570	A 570	A 574
QR code			
<a href="http://www.walter-tools.com/woc/">www.walter-tools.com/woc/</a>	W3270-A	W3270-E	W3271-E



## Exchangeable head QuadFit – Internal grooving

System



Machining

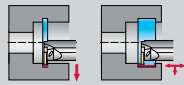

Designation

G4221-Q...-P

Insert width  $s$  [mm]

3–4

Cutting depth  $T_{max}$  [mm]

21

Coolant supply

Precision cooling

QuadFit size

Q32–Q50

Page in catalogue

A 576

QR code



[www.walter-tools.com/woc/](http://www.walter-tools.com/woc/)

G4221-Q-P

# Shank tool - Radial grooving

**G3011** 
**Walter Cut**

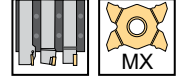
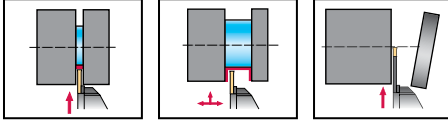
– Screw clamping



## Tool

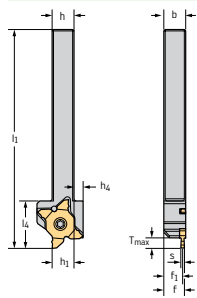

Designation	s mm	T <sub>max</sub> mm	h = h <sub>1</sub> mm	b mm	f <sub>1</sub> mm	l <sub>1</sub> mm	l <sub>4</sub> mm	h <sub>4</sub> mm	Type
G3011-1010R-MX22-2	0.5 - 3.3	6	10	10	8,3	120	28	7	MX22-2E ..
G3011-1212R-MX22-2		6	12	12	10,3	120	26	5	
G3011-1616R-MX22-2		6	16	16	14,2	120	26	4	
G3011-1010L-MX22-2	0.5 - 3.3	6	10	10	8,3	120	28	7	MX22-2E ..
G3011-1212L-MX22-2		6	12	12	10,3	120	26	5	
G3011-1616L-MX22-2		6	16	16	14,2	120	26	4	

Square shank

 Dimensional drawing shows right-hand version. |  $f = f_1 + s/2$  | Maximum cutting depth  $T_{max}$  – see cutting inserts | Refer to the Walter online catalogue for more product information: [www.walter-tools.com](http://www.walter-tools.com) | Bodies and assembly parts are included in the scope of delivery

## Assembly parts

	s [mm]	0.5 - 3.3
	Clamping screw for grooving insert Tightening torque	FS2570 (T20IP) 5 Nm
	Torx key	FS2572 (T20IP)

## Accessories

	s [mm]	0.5 - 3.3
	Torque screwdriver, analogue	FS2003
	Torque screwdriver, digital	FS2248
	Interchangeable blade	FS2015 (T20IP)

## Shank tool - Radial grooving

G3011 

Walter Cut

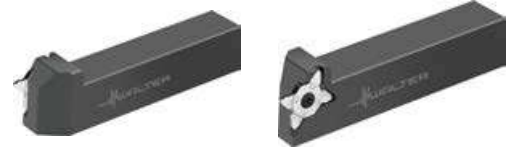

A2

– Screw clamping

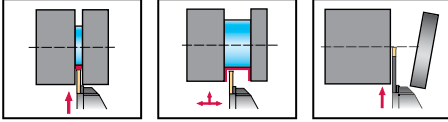

## Tool

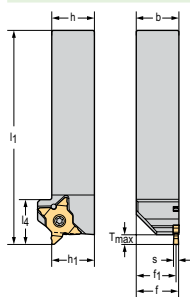

Designation	s mm	T <sub>max</sub> mm	h = h <sub>1</sub> mm	b mm	f <sub>1</sub> mm	l <sub>1</sub> mm	l <sub>4</sub> mm	Type
G3011-2020R-MX22-2	0.5 - 3.3	6	20	20	18,3	125	26	MX22-2E ..
G3011-2525R-MX22-2		6	25	25	23,3	125	26	
G3011-2020L-MX22-2	0.5 - 3.3	6	20	20	18,3	125	26	MX22-2E ..
G3011-2525L-MX22-2		6	25	25	23,3	125	26	

Square shank

Dimensional drawing shows right-hand version. |  $f = f_1 + s/2$  | Maximum cutting depth  $T_{max}$  – see cutting inserts | Refer to the Walter online catalogue for more product information: [www.walter-tools.com](http://www.walter-tools.com) | Bodies and assembly parts are included in the scope of delivery

## Assembly parts

	s [mm]	0.5 - 3.3
	Clamping screw for grooving insert Tightening torque	FS2570 (T20IP) 5 Nm
	Torx key	FS2572 (T20IP)

## Accessories

	s [mm]	0.5 - 3.3
	Torque screwdriver, analogue	FS2003
	Torque screwdriver, digital	FS2248
	Interchangeable blade	FS2015 (T20IP)

# Shank tool – Radial grooving

**G3011...-P** 

## Walter Cut

- Screw clamping
- Precision cooling

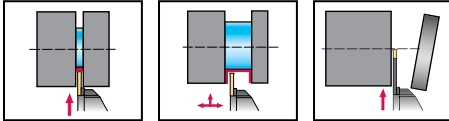

### Tool

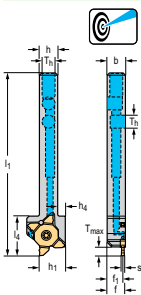

Designation	s mm	T <sub>max</sub> mm	h = h <sub>1</sub> mm	b mm	f <sub>1</sub> mm	l <sub>1</sub> mm	l <sub>4</sub> mm	h <sub>4</sub> mm	T <sub>1</sub>	Type
G3011-1212R-MX22-2-P	0.5 - 3.3	6	12	12	10,3	120	26	5	G1/8"	MX22-2E ..
G3011-1616R-MX22-2-P		6	16	16	14,3	120	26		G1/8"	
G3011-1616R-MX22-4-P	4 - 5.7	6	16	16	13,2	120	26	4	G1/8"	MX22-4E ..
G3011-1212L-MX22-2-P	0.5 - 3.3	6	12	12	10,3	120	26	5	G1/8"	MX22-2E ..
G3011-1616L-MX22-2-P		6	16	16	14,3	120	26		G1/8"	
G3011-1616L-MX22-4-P	4 - 5.7	6	16	16	13,2	120	26	4	G1/8"	MX22-4E ..

Square shank

Dimensional drawing shows right-hand version. |  $f = f_1 + s/2$  | Maximum cutting depth  $T_{max}$  – see cutting inserts | For the connection set for internal coolant supply with G1/8" thread, see „Assembly parts and accessories“ | The maximum recommended coolant pressure is 150 bar (2175 psi) | Refer to the Walter online catalogue for more product information: [www.walter-tools.com](http://www.walter-tools.com) | Bodies and assembly parts are included in the scope of delivery

### Assembly parts

	s [mm]	0.5 - 3.3	4 - 5.7
	Clamping screw for grooving insert Tightening torque	FS2570 (T20IP) 5 Nm	FS2571 (T20IP) 5 Nm
	G 1/8" threaded plug	FS2258 (SW 2)	FS2258 (SW 2)
	Torx key	FS2572 (T20IP)	FS2572 (T20IP)

### Accessories

	s [mm]	0.5 - 3.3-4 - 5.7
	Torque screwdriver, analogue	FS2003
	Torque screwdriver, digital	FS2248
	Interchangeable blade	FS2015 (T20IP)

## Shank tool – Radial grooving

G3011...-P 

## Walter Cut

- Screw clamping
- Precision cooling

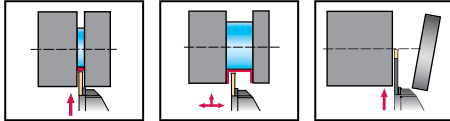

## Tool

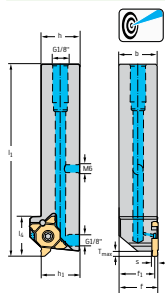

Designation	s mm	T <sub>max</sub> mm	h = h <sub>1</sub> mm	b mm	f <sub>1</sub> mm	l <sub>1</sub> mm	l <sub>4</sub> mm	Type
G3011-2020R-MX22-2-P	0.5 - 3.3	6	20	20	18,3	125	26	MX22-2E ..
G3011-2525R-MX22-2-P		6	25	25	23,3	125	26	
G3011-2020R-MX22-4-P	4 - 5.7	6	20	20	17,2	125	26	MX22-4E ..
G3011-2525R-MX22-4-P		6	25	25	22,2	125	26	
G3011-2020L-MX22-2-P	0.5 - 3.3	6	20	20	18,3	125	26	MX22-2E ..
G3011-2525L-MX22-2-P		6	25	25	23,3	125	26	
G3011-2020L-MX22-4-P	4 - 5.7	6	20	20	17,2	125	26	MX22-4E ..
G3011-2525L-MX22-4-P		6	25	25	22,2	125	26	

Square shank

Dimensional drawing shows right-hand version. |  $f = f_1 + s/2$  | Maximum cutting depth  $T_{max}$  – see cutting inserts | For the connection set for internal coolant supply with G1/8" thread, see „Assembly parts and accessories“ | The maximum recommended coolant pressure is 150 bar (2175 psi) | Refer to the Walter online catalogue for more product information: [www.walter-tools.com](http://www.walter-tools.com) | Bodies and assembly parts are included in the scope of delivery

## Assembly parts

	s [mm]	0.5 - 3.3	4 - 5.7
	Clamping screw for grooving insert Tightening torque	FS2570 (T20IP) 5 Nm	FS2571 (T20IP) 5 Nm
	G 1/8" threaded plug	FS2258 (SW 2)	FS2258 (SW 2)
	M6 threaded plug	FS2288 (SW 3)	FS2288 (SW 3)
	Torx key	FS2572 (T20IP)	FS2572 (T20IP)

## Accessories

	s [mm]	0.5 - 3.3 - 4 - 5.7
	Torque screwdriver, analogue	FS2003
	Torque screwdriver, digital	FS2248
	Interchangeable blade	FS2015 (T20IP)

## Shank tool – Radial grooving

**G3011...-P** inch

### Walter Cut

- Screw clamping
- Precision cooling

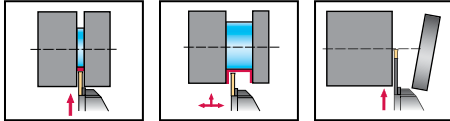

#### Tool

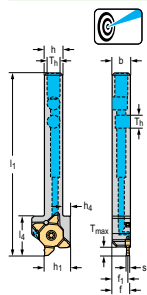

Designation	s inch	T <sub>max</sub> inch	h = h <sub>1</sub> inch	b inch	f <sub>1</sub> inch	l <sub>1</sub> inch	l <sub>4</sub> inch	h <sub>4</sub> inch	T <sub>h</sub>	Type
G3011.08R-MX22-2-P	0,020 - 0,130	0,236	0,500	0,500	0,434	4,724	1,024	0,169	5/16"X24	MX22-2E ..
G3011.10R-MX22-2-P		0,236	0,625	0,625	0,559	4,724	1,024		G1/8"	
G3011.08L-MX22-2-P	0,020 - 0,130	0,236	0,500	0,500	0,434	4,724	1,024	0,169	5/16"X24	MX22-2E ..
G3011.10L-MX22-2-P		0,236	0,625	0,625	0,559	4,724	1,024		G1/8"	

Square shank

Dimensional drawing shows right-hand version. |  $f = f_1 + s/2$  | Maximum cutting depth  $T_{max}$  – see cutting inserts | For the connection set for internal coolant supply with G1/8" thread, see „Assembly parts and accessories“ | The maximum recommended coolant pressure is 150 bar (2175 psi) | Refer to the Walter online catalogue for more product information: [www.walter-tools.com](http://www.walter-tools.com) | Bodies and assembly parts are included in the scope of delivery

#### Assembly parts

	s [inch]	0.020 - 0.130
	Clamping screw for grooving insert Tightening torque	FS2570 (T20IP) 3,688 lbs
	G 1/8" threaded plug	FS2258 (SW 2)
	UNF 5/16-24 threaded plug	FS2593 (SW 4)
	Torx key	FS2572 (T20IP)

#### Accessories

	s [inch]	0.020 - 0.130
	5/16" UNF angle connection	FS2594
	5/16" UNF connection element	FS2595
	Copper gasket	FS2598
	Torque screwdriver, analogue	FS2004
	Torque screwdriver, digital	FS2248
	Interchangeable blade	FS2015 (T20IP)

## Shank tool – Radial grooving

G3011...-P inch

## Walter Cut

- Screw clamping
- Precision cooling

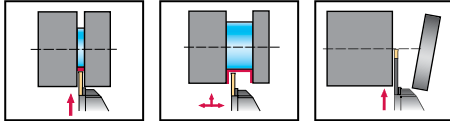

## Tool

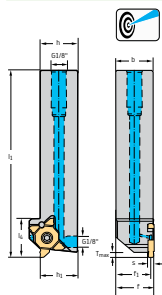

Designation	s inch	T <sub>max</sub> inch	h = h <sub>1</sub> inch	b inch	f <sub>1</sub> inch	l <sub>1</sub> inch	l <sub>4</sub> inch	Type
G3011.12R-MX22-2-P	0,020 - 0,130	0,236	0,750	0,750	0,684	5,906	1,024	MX22-2E ..
G3011.16R-MX22-2-P		0,236	1,000	1,000	0,934	5,906	1,024	
G3011.12R-MX22-4-P	0,157 - 0,224	0,236	0,750	0,750	0,639	5,906	1,024	MX22-4E ..
G3011.16R-MX22-4-P		0,236	1,000	1,000	0,889	5,906	1,024	
G3011.12L-MX22-2-P	0,020 - 0,130	0,236	0,750	0,750	0,684	5,906	1,024	MX22-2E ..
G3011.16L-MX22-2-P		0,236	1,000	1,000	0,934	5,906	1,024	
G3011.12L-MX22-4-P	0,157 - 0,224	0,236	0,750	0,750	0,639	5,906	1,024	MX22-4E ..
G3011.16L-MX22-4-P		0,236	1,000	1,000	0,889	5,906	1,024	

Square shank

Dimensional drawing shows right-hand version. |  $f = f_1 + s/2$  | Maximum cutting depth  $T_{max}$  – see cutting inserts | For the connection set for internal coolant supply with G1/8" thread, see „Assembly parts and accessories“ | The maximum recommended coolant pressure is 150 bar (2175 psi) | Refer to the Walter online catalogue for more product information: [www.walter-tools.com](http://www.walter-tools.com) | Bodies and assembly parts are included in the scope of delivery

## Assembly parts

	s [inch]	0.020 - 0.130	0.157 - 0.224
	Clamping screw for grooving insert Tightening torque	FS2570 (T20IP) 3,688 lbs	FS2571 (T20IP) 3,688 lbs
	G 1/8" threaded plug	FS2258 (SW 2)	FS2258 (SW 2)
	Torx key	FS2572 (T20IP)	FS2572 (T20IP)

## Accessories

	s [inch]	0.020 - 0.130–0.157 - 0.224
	Torque screwdriver, analogue	FS2004
	Torque screwdriver, digital	FS2248
	Interchangeable blade	FS2015 (T20IP)

# Shank tool – Radial grooving

**G3021...-P** 

## Walter Cut

- Screw clamping
- Precision cooling

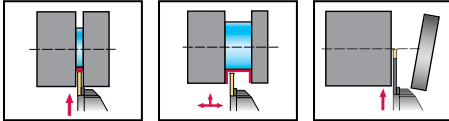

### Tool

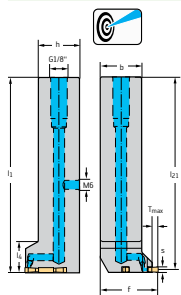

Designation	s mm	T <sub>max</sub> mm	h = h <sub>1</sub> mm	b mm	f <sub>1</sub> mm	l <sub>1</sub> mm	l <sub>4</sub> mm	l <sub>21</sub> mm	Type
G3021-2020R-MX22-2-P	0.5 - 3.3	6	20	20	30	125	19	123,3	MX22-2E ..
G3021-2525R-MX22-2-P		6	25	25	35	125	19	123,3	
G3021-2525R-MX22-4-P	4 - 5.7	6	25	25	35	127,3	19	124,5	MX22-4E ..
G3021-2020L-MX22-2-P	0.5 - 3.3	6	20	20	30	125	19	123,3	MX22-2E ..
G3021-2525L-MX22-2-P		6	25	25	35	125	19	123,3	
G3021-2525L-MX22-4-P	4 - 5.7	6	25	25	35	127,3	19	124,5	MX22-4E ..

Square shank

Dimensional drawing shows right-hand version. |  $l_1 = l_{21} + s/2$  | Maximum cutting depth  $T_{max}$  – see cutting inserts | For the connection set for internal coolant supply with G1/8" thread, see „Assembly parts and accessories“ | The maximum recommended coolant pressure is 150 bar (2175 psi) | Refer to the Walter online catalogue for more product information: [www.walter-tools.com](http://www.walter-tools.com) | Bodies and assembly parts are included in the scope of delivery

### Assembly parts

	s [mm]	0.5 - 3.3	4 - 5.7
	Clamping screw for grooving insert Tightening torque	FS2570 (T20IP) 5 Nm	FS2571 (T20IP) 5 Nm
	G 1/8" threaded plug	FS2258 (SW 2)	FS2258 (SW 2)
	M6 threaded plug	FS2288 (SW 3)	FS2288 (SW 3)
	Torx key	FS2572 (T20IP)	FS2572 (T20IP)

### Accessories

	s [mm]	0.5 - 3.3-4 - 5.7
	Torque screwdriver, analogue	FS2003
	Torque screwdriver, digital	FS2248
	Interchangeable blade	FS2015 (T20IP)



## Shank tool – Radial grooving

G3021...-P inch

## Walter Cut

- Screw clamping
- Precision cooling

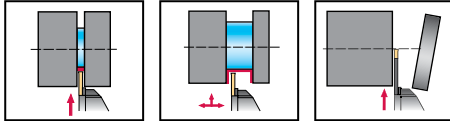

## Tool

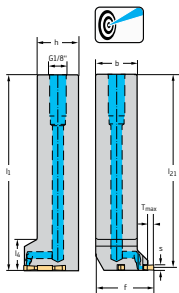

Designation	s inch	T <sub>max</sub> inch	h = h <sub>1</sub> inch	b inch	f <sub>1</sub> inch	l <sub>1</sub> inch	l <sub>4</sub> inch	l <sub>21</sub> inch	Type
G3021.16R-MX22-2-P	0,020 - 0,130	0,236	1,000	1,000	1,394	5,906	0,748	5,842	MX22-2E ..
G3021.16R-MX22-4-P	0,157 - 0,224	0,236	1,000	1,000	1,394	5,906	0,748	5,794	MX22-4E ..
G3021.16L-MX22-2-P	0,020 - 0,130	0,236	1,000	1,000	1,394	5,906	0,748	5,842	MX22-2E ..
G3021.16L-MX22-4-P	0,157 - 0,224	0,236	1,000	1,000	1,394	5,906	0,748	5,794	MX22-4E ..

Square shank

Dimensional drawing shows right-hand version. |  $l_1 = l_{21} + s/2$  | Maximum cutting depth  $T_{max}$  – see cutting inserts | For the connection set for internal coolant supply with G1/8" thread, see „Assembly parts and accessories“ | The maximum recommended coolant pressure is 150 bar (2175 psi) | Refer to the Walter online catalogue for more product information: [www.walter-tools.com](http://www.walter-tools.com) | Bodies and assembly parts are included in the scope of delivery

## Assembly parts

	s [inch]	0.020 - 0.130 - 0.157 - 0.224
	Clamping screw for grooving insert Tightening torque	FS2571 (T20IP) 3,688 lbs
	G 1/8" threaded plug	FS2258 (SW 2)
	Torx key	FS2572 (T20IP)

## Accessories

	s [inch]	0.020 - 0.130 - 0.157 - 0.224
	Torque screwdriver, analogue	FS2004
	Torque screwdriver, digital	FS2248
	Interchangeable blade	FS2015 (T20IP)

# Shank tool 3° – Radial grooving

**G3051...-P** 

## Walter Cut

- Grooving and parting off on high shoulders
- Precision cooling

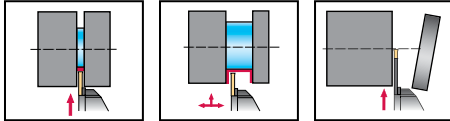

### Tool

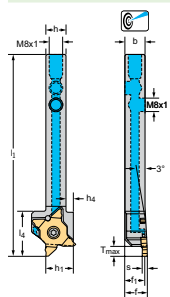

Designation	s mm	T <sub>max</sub> mm	h = h <sub>1</sub> mm	b mm	f <sub>1</sub> mm	l <sub>1</sub> mm	l <sub>4</sub> mm	h <sub>4</sub> mm	Type
G3051-1212R-MX22-2-P	0.5 - 3.3	6	12	12	13,3	120	26	5	MX22-2R ..
G3051-1212L-MX22-2-P	0.5 - 3.3	6	12	12	13,3	120	26	5	MX22-2L ..

Square shank

Dimensional drawing shows right-hand version. |  $f = f_1 + s/2$  | Maximum cutting depth  $T_{max}$  – see cutting inserts | For the connection set for internal coolant supply with G1/8" thread, see „Assembly parts and accessories“ | The maximum recommended coolant pressure is 150 bar (2175 psi) | When using G3051...R, the insert MX22-2R... is needed / When using G3051...L, the insert MX22-2L... is needed | Refer to the Walter online catalogue for more product information: [www.walter-tools.com](http://www.walter-tools.com) | Bodies and assembly parts are included in the scope of delivery

### Assembly parts

	s [mm]	0.5 - 3.3
	Clamping screw for grooving insert Tightening torque	FS2570 (T20IP) 5 Nm
	M8X1 threaded plug	FS2587 (SW 4)
	Torx key	FS2572 (T20IP)

### Accessories

	s [mm]	0.5 - 3.3
	M8x1 angle connection	FS2596
	M8x1 connection element	FS2597
	Copper gasket	FS2598
	Torque screwdriver, analogue	FS2003
	Torque screwdriver, digital	FS2248
	Interchangeable blade	FS2015 (T20IP)

## Shank tool 3° – Radial grooving

G3051...-P 

## Walter Cut

- Grooving and parting off on high shoulders
- Precision cooling

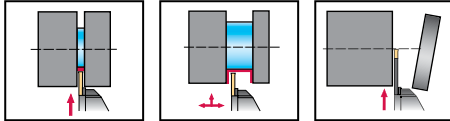

## Tool

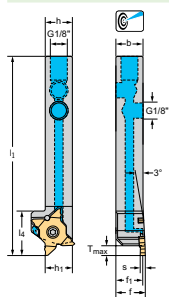

Designation	s mm	T <sub>max</sub> mm	h = h <sub>1</sub> mm	b mm	f <sub>1</sub> mm	l <sub>1</sub> mm	l <sub>4</sub> mm	Type
G3051-1616R-MX22-2-P	0.5 - 3.3	6	16	16	17,3	120	26	MX22-2R ..
G3051-1616L-MX22-2-P	0.5 - 3.3	6	16	16	17,3	120	26	MX22-2L ..

Square shank

Dimensional drawing shows right-hand version. |  $f_1 = F - s/2$  | Maximum cutting depth  $T_{max}$  – see cutting inserts | For the connection set for internal coolant supply with G1/8" thread, see „Assembly parts and accessories“ | The maximum recommended coolant pressure is 150 bar (2175 psi) | When using G3051...R, the insert MX22-2R... is needed / When using G3051...L, the insert MX22-2L... is needed | Refer to the Walter online catalogue for more product information: [www.walter-tools.com](http://www.walter-tools.com) | Bodies and assembly parts are included in the scope of delivery

## Assembly parts

	s [mm]	0.5 - 3.3
	Clamping screw for grooving insert Tightening torque	FS2570 (T20IP) 5 Nm
	G 1/8" threaded plug	FS2258 (SW 2)
	Torx key	FS2572 (T20IP)

## Accessories

	s [mm]	0.5 - 3.3
	Torque screwdriver, analogue	FS2003
	Torque screwdriver, digital	FS2248
	Interchangeable blade	FS2015 (T20IP)

# Shank tool 3° – Radial grooving

**G3051...-P** 

## Walter Cut

- Grooving and parting off on high shoulders
- Precision cooling

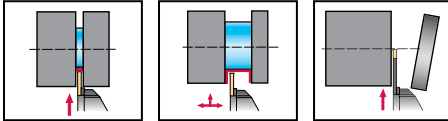

### Tool

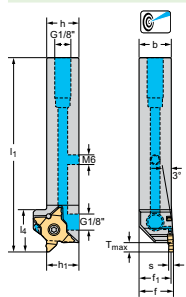

Designation	s mm	T <sub>max</sub> mm	h = h <sub>1</sub> mm	b mm	f <sub>1</sub> mm	l <sub>1</sub> mm	l <sub>4</sub> mm	Type
G3051-2020R-MX22-2-P	0.5 - 3.3	6	20	20	21,3	125	26	MX22-2R ..
G3051-2525R-MX22-2-P		6	25	25	26,3	125	26	
G3051-2020L-MX22-2-P	0.5 - 3.3	6	20	20	21,3	125	26	MX22-2L ..
G3051-2525L-MX22-2-P		6	25	25	26,3	125	26	

Square shank

Dimensional drawing shows right-hand version. |  $f = f_1 + s/2$  | Maximum cutting depth  $T_{max}$  – see cutting inserts | The maximum recommended coolant pressure is 150 bar (2175 psi) | When using G3051...R, the insert MX22-2R... is needed / When using G3051...L, the insert MX22-2L... is needed | Refer to the Walter online catalogue for more product information: [www.walter-tools.com](http://www.walter-tools.com) | Bodies and assembly parts are included in the scope of delivery

### Assembly parts

	s [mm]	0.5 - 3.3
	Clamping screw for grooving insert Tightening torque	FS2570 (T20IP) 5 Nm
	G 1/8" threaded plug	FS2258 (SW 2)
	M6 threaded plug	FS2288 (SW 3)
	Torx key	FS2572 (T20IP)

### Accessories

	s [mm]	0.5 - 3.3
	Torque screwdriver, analogue	FS2003
	Torque screwdriver, digital	FS2248
	Interchangeable blade	FS2015 (T20IP)

## Shank tool 3° – Radial grooving

G3051...-P inch

### Walter Cut

- Grooving and parting off on high shoulders
- Precision cooling

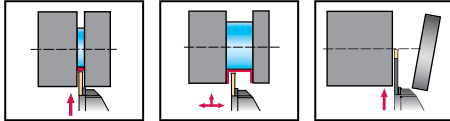

### Tool

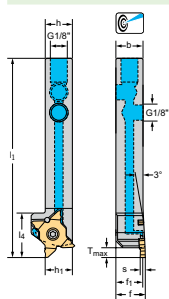

Designation	s inch	T <sub>max</sub> inch	h = h <sub>1</sub> inch	b inch	f <sub>1</sub> inch	l <sub>1</sub> inch	l <sub>4</sub> inch	Type
G3051.10R-MX22-2-P	0,020 - 0,130	0,236	0,625	0,625	0,678	4,724	1,024	MX22-2R ..
G3051.10L-MX22-2-P	0,020 - 0,130	0,236	0,625	0,625	0,678	4,724	1,024	MX22-2L ..

Square shank

Dimensional drawing shows right-hand version. |  $f = f_1 + s/2$  | Maximum cutting depth  $T_{max}$  – see cutting inserts | The maximum recommended coolant pressure is 150 bar (2175 psi) | When using G3051...R, the insert MX22-2R... is needed / When using G3051...L, the insert MX22-2L... is needed | Refer to the Walter online catalogue for more product information: [www.walter-tools.com](http://www.walter-tools.com) | Bodies and assembly parts are included in the scope of delivery

### Assembly parts

	s [inch]	0.020 - 0.130
	Clamping screw for grooving insert Tightening torque	FS2570 (T20IP) 3,688 lbs
	G 1/8" threaded plug	FS2258 (SW 2)
	Torx key	FS2572 (T20IP)

### Accessories

	s [inch]	0.020 - 0.130
	Torque screwdriver, analogue	FS2004
	Torque screwdriver, digital	FS2248
	Interchangeable blade	FS2015 (T20IP)

# Shank tool 3° – Radial grooving

**G3051...-P** inch

## Walter Cut

- Grooving and parting off on high shoulders
- Precision cooling

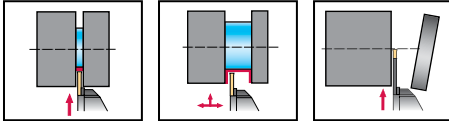

### Tool

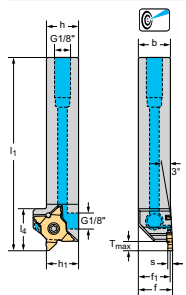

Designation	s inch	T <sub>max</sub> inch	h = h <sub>1</sub> inch	b inch	f <sub>1</sub> inch	l <sub>1</sub> inch	l <sub>4</sub> inch	Type
G3051.12R-MX22-2-P	0,020 - 0,130	0,236	0,750	0,750	0,803	5,906	1,024	MX22-2R ..
G3051.16R-MX22-2-P		0,236	1,000	1,000	1,053	5,906	1,024	
G3051.12L-MX22-2-P	0,020 - 0,130	0,236	0,750	0,750	0,803	5,906	1,024	MX22-2L ..
G3051.16L-MX22-2-P		0,236	1,000	1,000	1,053	5,906	1,024	

Square shank

Dimensional drawing shows right-hand version. |  $f = f_1 + s/2$  | Maximum cutting depth  $T_{max}$  – see cutting inserts | For the connection set for internal coolant supply with G1/8" thread, see „Assembly parts and accessories“ | The maximum recommended coolant pressure is 150 bar (2175 psi) | When using G3051...R, the insert MX22-2R... is needed / When using G3051...L, the insert MX22-2L... is needed | Refer to the Walter online catalogue for more product information: [www.walter-tools.com](http://www.walter-tools.com) | Bodies and assembly parts are included in the scope of delivery

### Assembly parts

	s [inch]	0.020 - 0.130
Clamping screw for grooving insert Tightening torque		FS2570 (T20IP) 3,688 lbs
G 1/8" threaded plug		FS2258 (SW 2)
Torx key		FS2572 (T20IP)

### Accessories

	s [inch]	0.020 - 0.130
Torque screwdriver, analogue		FS2004
Torque screwdriver, digital		FS2248
Interchangeable blade		FS2015 (T20IP)

## Shank tool – Radial grooving

G4014 

Walter Cut



– Side screw clamping

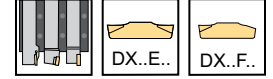
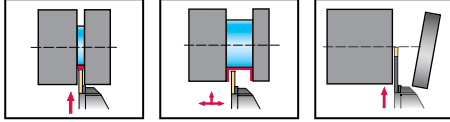

## Tool

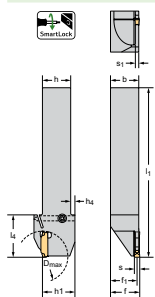

Square shank

Designation	s mm	D <sub>max</sub> mm	h = h <sub>1</sub> mm	b mm	f <sub>1</sub> mm	l <sub>1</sub> mm	h <sub>4</sub> mm	l <sub>4</sub> mm	s <sub>1</sub> mm	Type		
G4014-1010R-1T12DX18	1	25	10	10	9,6	110	3,5	23	0,8	DX18-1E1 ..		
G4014-1212R-1T12DX18		25	12	12	11,6	110	3	22,3	0,8			
G4014-1010R-1.5T10DX18	1,5	20	10	10	9,4	110	3,5	22	1,2	DX18-1E1.5 ..		
G4014-1212R-1.5T12DX18		25	12	12	11,4	110	3	22,3	1,2			
G4014-1616R-1.5T12DX18	2	25	16	16	15,4	120	4	24	1,2	DX18-2E2 ..		
G4014-1010R-2T10DX18		20	10	10	9,2	110	3,5	22	1,6			
G4014-1212R-2T12DX18		25	12	12	11,2	110	3	22,3	1,6			
G4014-1616R-2T12DX18		25	16	16	15,2	120	4	24	1,6			
G4014-1616R-2T17DX18		35	16	16	15,2	120	4	30	1,6			
G4014-2020R-2T17DX18	3	35	20	20	19,2	120	3	30	1,6	DX18-2E2 ..		
G4014-1010L-1T12DX18		25	10	10	9,6	110	3,5	23	0,8			
G4014-1212L-1T12DX18		25	12	12	11,6	110	3	22,3	0,8			
G4014-1010L-1.5T10DX18		1,5	20	10	10	9,4	110	3,5	22		1,2	DX18-1E1.5 ..
G4014-1212L-1.5T12DX18	25		12	12	11,4	110	3	22,3	1,2			
G4014-1616L-1.5T12DX18	2	25	16	16	15,4	120	4	24	1,2	DX18-2E2 ..		
G4014-1010L-2T10DX18		20	10	10	9,2	110	3,5	22	1,6			
G4014-1212L-2T12DX18		25	12	12	11,2	110	3	22,3	1,6			
G4014-1616L-2T12DX18		25	16	16	15,2	120	4	24	1,6			
G4014-1616L-2T17DX18		35	16	16	15,2	120	4	30	1,6			
G4014-2020L-2T17DX18	3	35	20	20	19,2	120	3	30	1,6	DX18-2E2 ..		
G4014-1010L-3T12DX18		25	12	12	10,8	110	3	22,3	2,4			
G4014-1616R-3T17DX18		35	16	16	14,8	120	4	30	2,4			
G4014-2020R-3T17DX18		35	20	20	18,8	120	3	30	2,4			
G4014-1010L-3T12DX18	1	25	10	10	9,6	110	3,5	23	0,8	DX18-1E1 ..		
G4014-1212L-3T12DX18		25	12	12	11,6	110	3	22,3	0,8			
G4014-1010L-1.5T10DX18		1,5	20	10	10	9,4	110	3,5	22		1,2	DX18-1E1.5 ..
G4014-1212L-1.5T12DX18			25	12	12	11,4	110	3	22,3		1,2	
G4014-1616L-1.5T12DX18	2	25	16	16	15,4	120	4	24	1,2	DX18-2E2 ..		
G4014-1010L-2T10DX18		20	10	10	9,2	110	3,5	22	1,6			
G4014-1212L-2T12DX18		25	12	12	11,2	110	3	22,3	1,6			
G4014-1616L-2T12DX18		25	16	16	15,2	120	4	24	1,6			
G4014-1616L-2T17DX18		35	16	16	15,2	120	4	30	1,6			
G4014-2020L-2T17DX18	3	35	20	20	19,2	120	3	30	1,6	DX18-2E2 ..		
G4014-1010L-3T12DX18		25	12	12	10,8	110	3	22,3	2,4			
G4014-1616L-3T17DX18		35	16	16	14,8	120	4	30	2,4			
G4014-2020L-3T17DX18		35	20	20	18,8	120	3	30	2,4			

Dimensional drawing shows right-hand version. |  $f = f_1 + s/2$  | Refer to the Walter online catalogue for more product information: [www.walter-tools.com](http://www.walter-tools.com) | Bodies and assembly parts are included in the scope of delivery

## Assembly parts

	s (mm)	1	1,5–3
	Clamping screw for grooving insert Tightening torque	FS2586 (T15IP) 2 Nm	FS2586 (T15IP) 2 Nm
	Screw plug	FS2589	FS2589
	Torx key	FS1465 (T15IP)	FS1465 (T15IP)

## Accessories

	s (mm)	1–3
	Torque screwdriver, analogue	FS2003
	Interchangeable blade	FS2014 (T15IP)
	Torque screwdriver, digital	FS2248

# Shank tool – Radial grooving

G4014...-P

## Walter Cut

- Side screw clamping
- Precision cooling

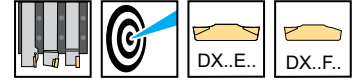
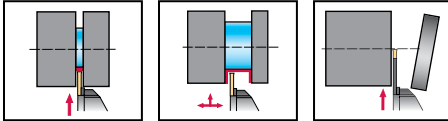

### Tool

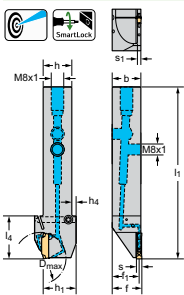

Designation	s mm	D <sub>max</sub> mm	h = h <sub>1</sub> mm	b mm	f <sub>1</sub> mm	l <sub>1</sub> mm	h <sub>4</sub> mm	l <sub>4</sub> mm	s <sub>1</sub> mm	Type
G4014-1212R-2T12DX18-P	2	25	12	12	11,2	110	3	22,3	1,6	DX18-2E2 ..
G4014-1212R-2.5T12DX18-P	2,5	25	12	12	11	110	3	22,3	2,1	DX18-2E2.5 ..
G4014-1212R-3T12DX18-P	3	25	12	12	10,8	110	3	22,3	2,4	DX18-3E3 .. DX18-3F3 ..
G4014-1212L-2T12DX18-P	2	25	12	12	11,2	110	3	22,3	1,6	DX18-2E2 ..
G4014-1212L-2.5T12DX18-P	2,5	25	12	12	11	110	3	22,3	2,1	DX18-2E2.5 ..
G4014-1212L-3T12DX18-P	3	25	12	12	10,8	110	3	22,3	2,4	DX18-3E3 .. DX18-3F3 ..

Square shank

Dimensional drawing shows right-hand version. | The maximum recommended coolant pressure is 150 bar (2175 psi) |  $f = f_1 + s/2$  | Refer to the Walter online catalogue for more product information: [www.walter-tools.com](http://www.walter-tools.com) | Bodies and assembly parts are included in the scope of delivery

### Assembly parts

	s [mm]	2-3
	Clamping screw for grooving insert Tightening torque	FS2586 (T15IP) 2 Nm
	Screw plug	FS2589
	M8X1 threaded plug	FS2587 (SW 4)
	Torx key	FS1465 (T15IP)

### Accessories

	s [mm]	2-3
	Torque screwdriver, analogue	FS2003
	Interchangeable blade	FS2014 (T15IP)
	M8x1 angle connection	FS2596
	M8x1 connection element	FS2597
	Copper gasket	FS2598
	Torque screwdriver, digital	FS2248



## Shank tool – Radial grooving

G4014...-P 

## Walter Cut

- Side screw clamping
- Precision cooling

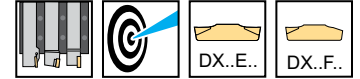
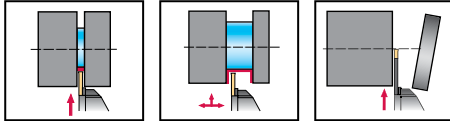

## Tool

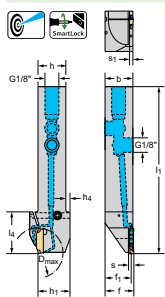

Designation	s mm	D <sub>max</sub> mm	h = h <sub>1</sub> mm	b mm	f <sub>1</sub> mm	l <sub>1</sub> mm	h <sub>4</sub> mm	l <sub>4</sub> mm	s <sub>1</sub> mm	Type
G4014-1616R-2T12DX18-P	2	25	16	16	15,2	120	4	24	1,6	DX18-2E2 ..
G4014-1616R-2T17DX18-P		35	16	16	15,2	120	4	30	1,6	
G4014-1616R-2.5T17DX18-P	2,5	35	16	16	15	120	4	30	2,1	DX18-2E2.5 ..
G4014-1616R-3T17DX18-P	3	35	16	16	14,8	120	4	30	2,4	DX18-3E3 .. DX18-3F3 ..
G4014-1616L-2T12DX18-P	2	25	16	16	15,2	120	4	24	1,6	DX18-2E2 ..
G4014-1616L-2T17DX18-P		35	16	16	15,2	120	4	30	1,6	
G4014-1616L-2.5T17DX18-P	2,5	35	16	16	15	120	4	30	2,1	DX18-2E2.5 ..
G4014-1616L-3T17DX18-P	3	35	16	16	14,8	120	4	30	2,4	DX18-3E3 .. DX18-3F3 ..

Square shank

Dimensional drawing shows right-hand version. | For the connection set for internal coolant supply with G1/8" thread, see „Assembly parts and accessories“ |  $f = f_1 + s/2$   
 | The maximum recommended coolant pressure is 150 bar (2175 psi) | Refer to the Walter online catalogue for more product information: [www.walter-tools.com](http://www.walter-tools.com) | Bodies and assembly parts are included in the scope of delivery

## Assembly parts

	s [mm]	2-3
	Clamping screw for grooving insert Tightening torque	FS2585 (T15IP) 2,5 Nm
	Screw plug	FS2589
	G 1/8" threaded plug	FS2258 (SW 2)
	Torx key	FS1465 (T15IP)

## Accessories

	s [mm]	2-3
	Torque screwdriver, analogue	FS2003
	Interchangeable blade	FS2014 (T15IP)
	Torque screwdriver, digital	FS2248

# Shank tool – Radial grooving

**G4014...-P** mm

## Walter Cut

- Side screw clamping
- Precision cooling

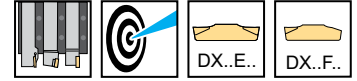
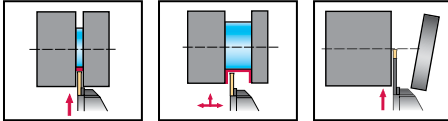

### Tool

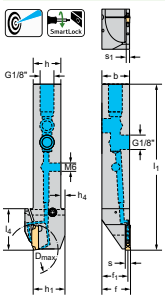

Designation	s mm	D <sub>max</sub> mm	h = h <sub>1</sub> mm	b mm	f <sub>1</sub> mm	l <sub>1</sub> mm	h <sub>4</sub> mm	l <sub>4</sub> mm	s <sub>1</sub> mm	Type
G4014-2020R-2T17DX18-P	2	35	20	20	19,2	120	3	30	1,6	DX18-2E2 ..
G4014-2020R-3T17DX18-P	3	35	20	20	18,8	120	3	30	2,4	DX18-3E3 .. DX18-3F3 ..
G4014-2020L-2T17DX18-P	2	35	20	20	19,2	120	3	30	1,6	DX18-2E2 ..
G4014-2020L-3T17DX18-P	3	35	20	20	18,8	120	3	30	2,4	DX18-3E3 .. DX18-3F3 ..

Square shank

Dimensional drawing shows right-hand version. | For the connection set for internal coolant supply with G1/8" thread, see „Assembly parts and accessories“ |  $f = f_1 + s/2$  | The maximum recommended coolant pressure is 150 bar (2175 psi) | Refer to the Walter online catalogue for more product information: [www.walter-tools.com](http://www.walter-tools.com) | Bodies and assembly parts are included in the scope of delivery

### Assembly parts

	s [mm]	2-3
	Clamping screw for grooving insert Tightening torque	FS2585 (T15IP) 2,5 Nm
	Screw plug	FS2589
	G 1/8" threaded plug	FS2258 (SW 2)
	M6 threaded plug	FS2288 (SW 3)
	Torx key	FS1465 (T15IP)

### Accessories

	s [mm]	2-3
	Torque screwdriver, analogue	FS2003
	Interchangeable blade	FS2014 (T15IP)
	Torque screwdriver, digital	FS2248

## Shank tool – Radial grooving

G4014 inch

Walter Cut





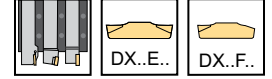
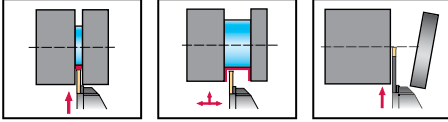

A2

– Side screw clamping

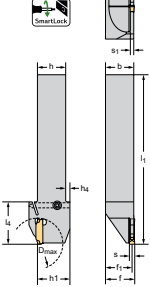



## Tool

		Designation	s inch	D <sub>max</sub> inch	h = h <sub>1</sub> inch	b inch	f <sub>1</sub> inch	l <sub>1</sub> inch	h <sub>4</sub> inch	l <sub>4</sub> inch	s <sub>1</sub> inch	Type
 		G4014.08R-1.5T12DX18	0,059	0,984	0,500	0,500	0,476	4,331	0,091	0,878	0,047	DX18-1E1.5 ..
		G4014.08L-1.5T12DX18	0,059	0,984	0,500	0,500	0,476	4,331	0,091	0,878	0,047	DX18-1E1.5 ..
		G4014.10L-3T17DX18	0,118	1,378	0,625	0,625	0,579	4,724	0,161	1,181	0,094	DX18-3E3 .. DX18-3F3 ..



Square shank

Dimensional drawing shows right-hand version. |  $f = f_1 + s/2$  | Refer to the Walter online catalogue for more product information: [www.walter-tools.com](http://www.walter-tools.com) | Bodies and assembly parts are included in the scope of delivery

## Assembly parts

		s [inch]	0,059	0,118
	Clamping screw for grooving insert Tightening torque		FS2586 (T15IP) 1,475 lbs	FS2585 (T15IP) 1,844 lbs
	Screw plug		FS2589	FS2589
	Torx key		FS1465 (T15IP)	FS1465 (T15IP)

## Accessories

		s [inch]	0,059–0,118
	Torque screwdriver, analogue		FS2004
	Interchangeable blade		FS2014 (T15IP)
	Torque screwdriver, digital		FS2248

# Shank tool – Radial grooving

G4014...-P inch

## Walter Cut

- Side screw clamping
- Precision cooling

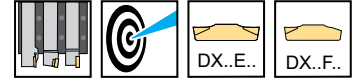
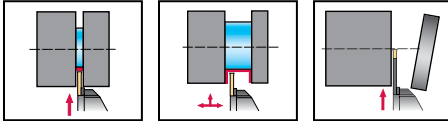

### Tool

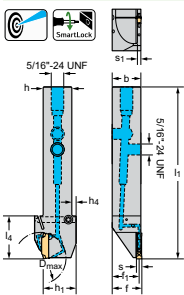

Designation	s inch	D <sub>max</sub> inch	h = h <sub>1</sub> inch	b inch	f <sub>1</sub> inch	l <sub>1</sub> inch	h <sub>4</sub> inch	l <sub>4</sub> inch	s <sub>1</sub> inch	Type
G4014.08R-2T12DX18-P	0,079	0,984	0,500	0,500	0,469	4,331	0,091	0,878	0,063	DX18-2E2 ..
G4014.08R-3T12DX18-P	0,118	0,984	0,500	0,500	0,453	4,331	0,091	0,878	0,094	DX18-3E3 .. DX18-3F3 ..
G4014.08L-2T12DX18-P	0,079	0,984	0,500	0,500	0,469	4,331	0,091	0,878	0,063	DX18-2E2 ..
G4014.08L-3T12DX18-P	0,118	0,984	0,500	0,500	0,453	4,331	0,091	0,878	0,094	DX18-3E3 .. DX18-3F3 ..

Square shank

Dimensional drawing shows right-hand version. | The maximum recommended coolant pressure is 150 bar (2175 psi) |  $f = f_1 + s/2$  | Refer to the Walter online catalogue for more product information: [www.walter-tools.com](http://www.walter-tools.com) | Bodies and assembly parts are included in the scope of delivery

### Assembly parts

	s [inch]	0,079–0,118
	Clamping screw for grooving insert Tightening torque	FS2586 (T15IP) 1,475 lbs
	Screw plug	FS2589
	UNF 5/16-24 threaded plug	FS2593 (SW 4)
	Torx key	FS1465 (T15IP)

### Accessories

	s [inch]	0,079–0,118
	Torque screwdriver, analogue	FS2004
	Interchangeable blade	FS2014 (T15IP)
	5/16" UNF angle connection	FS2594
	5/16" UNF connection element	FS2595
	Copper gasket	FS2598
	Torque screwdriver, digital	FS2248

## Shank tool – Radial grooving

G4014...-P inch

## Walter Cut

- Side screw clamping
- Precision cooling

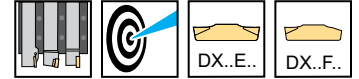
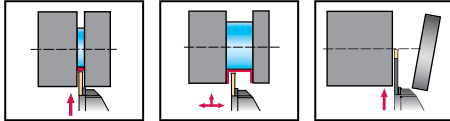

## Tool

	Designation	s inch	D <sub>max</sub> inch	h = h <sub>1</sub> inch	b inch	f <sub>1</sub> inch	h <sub>1</sub> inch	h <sub>4</sub> inch	l <sub>4</sub> inch	s <sub>1</sub> inch	Type
	G4014.10R-2T17DX18-P	0,079	1,378	0,625	0,625	0,594	4,724	0,161	1,181	0,063	DX18-2E2 ..
	G4014.12R-2T17DX18-P		1,378	0,750	0,750	0,717	4,724	0,118	1,181	0,063	
	G4014.10R-3T17DX18-P	0,118	1,378	0,625	0,625	0,579	4,724	0,161	1,181	0,094	DX18-3E3 .. DX18-3F3 ..
	G4014.12R-3T17DX18-P		1,378	0,750	0,750	0,701	4,724	0,118	1,181	0,094	
	G4014.10L-2T17DX18-P	0,079	1,378	0,625	0,625	0,594	4,724	0,161	1,181	0,063	DX18-2E2 ..
	G4014.12L-2T17DX18-P		1,378	0,750	0,750	0,717	4,724	0,118	1,181	0,063	
	G4014.10L-3T17DX18-P	0,118	1,378	0,625	0,625	0,579	4,724	0,161	1,181	0,094	DX18-3E3 .. DX18-3F3 ..
	G4014.12L-3T17DX18-P		1,378	0,750	0,750	0,701	4,724	0,118	1,181	0,094	

Square shank

Dimensional drawing shows right-hand version. | For the connection set for internal coolant supply with G1/8" thread, see „Assembly parts and accessories“ |  $f = f_1 + s/2$   
 | The maximum recommended coolant pressure is 150 bar (2175 psi) | Refer to the Walter online catalogue for more product information: [www.walter-tools.com](http://www.walter-tools.com) | Bodies and assembly parts are included in the scope of delivery

## Assembly parts

	s [inch]	0,079–0,118
	Clamping screw for grooving insert Tightening torque	FS2585 (T15IP) 1,844 lbs
	Screw plug	FS2589
	G 1/8" threaded plug	FS2258 (SW 2)
	M6 threaded plug	FS2288 (SW 3)
	Torx key	FS1465 (T15IP)

## Accessories

	s [inch]	0,079–0,118
	Torque screwdriver, analogue	FS2004
	Interchangeable blade	FS2014 (T15IP)
	Torque screwdriver, digital	FS2248

# Shank tool – Radial grooving

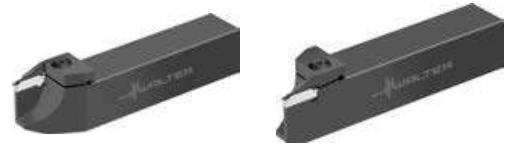
**G4011** 
**Walter Cut**

– Screw clamping

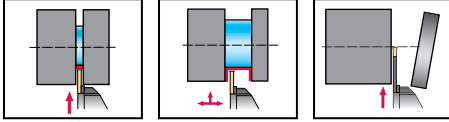

## Tool

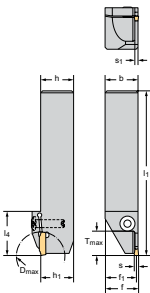

Designation	s mm	T <sub>max</sub> mm	D <sub>max</sub> mm	h = h <sub>1</sub> mm	b mm	f <sub>1</sub> mm	l <sub>1</sub> mm	l <sub>4</sub> mm	s <sub>1</sub> mm	Type
G4011-2525R-2T17DX18	2	17	35	25	25	24,2	125	33,5	1,6	DX18-2E2 ..
G4011-2525R-2.5T17DX18	2,5	17	35	25	25	24	125	33,5	2,1	DX18-2E2.5 ..
G4011-2525R-3T17DX18	3	17	35	25	25	23,8	125	33,5	2,4	DX18-3E3 .. DX18-3F3 ..
G4011-2525L-2T17DX18	2	17	35	25	25	24,2	125	33,5	1,6	DX18-2E2 ..
G4011-2525L-2.5T17DX18	2,5	17	35	25	25	24	125	33,5	2,1	DX18-2E2.5 ..
G4011-2525L-3T17DX18	3	17	35	25	25	23,8	125	33,5	2,4	DX18-3E3 .. DX18-3F3 ..

Square shank

 Dimensional drawing shows right-hand version. |  $f_1 = f - s/2$  | If no  $D_{max}$  is specified, there is no diameter limit on the tool. | Refer to the Walter online catalogue for more product information: [www.walter-tools.com](http://www.walter-tools.com) | Bodies and assembly parts are included in the scope of delivery

## Assembly parts

	s [mm]	2–3
	Clamping screw for grooving insert Tightening torque	FS2118 (T20IP) 5 Nm
	Allen key	FS1464 (T20IP)

## Accessories

	s [mm]	2–3
	Torque screwdriver, analogue	FS2003
	Torque screwdriver, digital	FS2248
	Interchangeable blade	FS2015 (T20IP)

## Shank tool – Radial grooving

G4011 

## Walter Cut



– Screw clamping

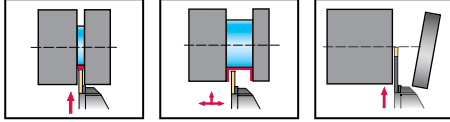

## Tool

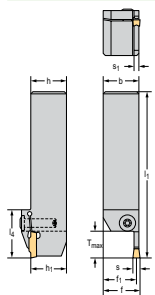

Square shank

Designation	s mm	T <sub>max</sub> mm	h = h <sub>1</sub> mm	b mm	f <sub>1</sub> mm	l <sub>1</sub> mm	l <sub>4</sub> mm	s <sub>1</sub> mm	Type
G4011-2020R-2T10DX18	2	10	20	20	19,2	125	33,5	1,6	DX18-2E2 ..
G4011-2525R-2T10DX18		10	25	25	24,2	125	28	1,6	
G4011-1616R-3T10DX18	3	10	16	16	14,3	125	33,5	2,4	DX18-3E3 .. DX18-3F3 ..
G4011-2020R-3T10DX18		10	20	20	18,8	125	33,5	2,4	
G4011-2525R-3T10DX18	4	10	25	25	23,8	125	28	2,4	DX18-4E4 .. DX18-4F4 ..
G4011-1616R-4T10DX18		10	16	16	14,8	125	33,5	3,4	
G4011-2020R-4T10DX18	4	10	20	20	18,3	125	33,5	3,4	DX18-4E4 .. DX18-4F4 ..
G4011-2020R-4T17DX18		17	20	20	18,3	125	33,5	3,4	
G4011-2525R-4T10DX18		10	25	25	23,2	125	33,5	3,4	
G4011-2525R-4T17DX18		17	25	25	23,2	125	33,5	3,4	
G4011-2020L-2T10DX18	2	10	20	20	19,2	125	33,5	1,6	DX18-2E2 ..
G4011-2525L-2T10DX18		10	25	25	24,2	125	28	1,6	
G4011-2020L-3T10DX18	3	10	20	20	18,8	125	33,5	2,4	DX18-3E3 .. DX18-3F3 ..
G4011-2525L-3T10DX18		10	25	25	23,8	125	28	2,4	
G4011-2020L-4T10DX18	4	10	20	20	18,3	125	33,5	3,4	DX18-4E4 .. DX18-4F4 ..
G4011-2020L-4T17DX18		17	20	20	18,3	125	33,5	3,4	
G4011-2525L-4T10DX18		10	25	25	23,2	125	33,5	3,4	
G4011-2525L-4T17DX18		17	25	25	23,2	125	33,5	3,4	

Dimensional drawing shows right-hand version. |  $f_1 = f - s/2$  |  $f = f_1 + s/2$  | If no  $D_{max}$  is specified, there is no diameter limit on the tool. | If no  $D_2$  or  $D_{max}$  is specified, there is no diameter limit on the tool. | Refer to the Walter online catalogue for more product information: [www.walter-tools.com](http://www.walter-tools.com) | Bodies and assembly parts are included in the scope of delivery

## Assembly parts

	s [mm]	2–4
	Clamping screw for grooving insert Tightening torque	FS2118 (T20IP) 5 Nm
	Allen key	FS1464 (T20IP)

## Accessories

	s [mm]	2–4
	Torque screwdriver, analogue	FS2003
	Torque screwdriver, digital	FS2248
	Interchangeable blade	FS2015 (T20IP)

# Shank tool – Radial grooving

**G4011...-P** mm

## Walter Cut

- Screw clamping
- Precision cooling

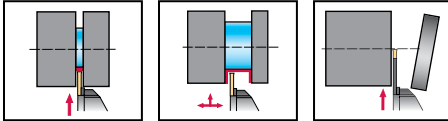
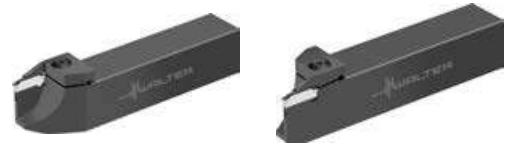

### Tool

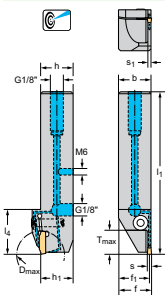

Designation	s mm	T <sub>max</sub> mm	D <sub>max</sub> mm	h = h <sub>1</sub> mm	b mm	f <sub>1</sub> mm	l <sub>1</sub> mm	l <sub>4</sub> mm	s <sub>1</sub> mm	Type
G4011-2525R-2T17DX18-P	2	17	35	25	25	24,2	125	33,5	1,6	DX18-2E2 ..
G4011-2525R-2.5T17DX18-P	2,5	17	35	25	25	24	125	33,5	2,1	DX18-2E2.5 ..
G4011-2525R-3T17DX18-P	3	17	35	25	25	23,8	125	33,5	2,4	DX18-3E3 .. DX18-3F3 ..
G4011-2525L-2T17DX18-P	2	17	35	25	25	24,2	125	33,5	1,6	DX18-2E2 ..
G4011-2525L-2.5T17DX18-P	2,5	17	35	25	25	24	125	33,5	2,1	DX18-2E2.5 ..
G4011-2525L-3T17DX18-P	3	17	35	25	25	23,8	125	33,5	2,4	DX18-3E3 .. DX18-3F3 ..

Square shank

Dimensional drawing shows right-hand version. |  $f_1 = f - s/2$  | If no  $D_{max}$  is specified, there is no diameter limit on the tool. | The maximum recommended coolant pressure is 150 bar (2175 psi) | Refer to the Walter online catalogue for more product information: [www.walter-tools.com](http://www.walter-tools.com) | Bodies and assembly parts are included in the scope of delivery

### Assembly parts

	s [mm]	2-3
	Clamping screw for grooving insert Tightening torque	FS2118 (T20IP) 5 Nm
	G 1/8" threaded plug	FS2258 (SW 2)
	M6 threaded plug	FS2288 (SW 3)
	Allen key	FS1464 (T20IP)

### Accessories

	s [mm]	2-3
	Torque screwdriver, analogue	FS2003
	Torque screwdriver, digital	FS2248
	Interchangeable blade	FS2015 (T20IP)



## Shank tool – Radial grooving

G4011...-P 

## Walter Cut

- Screw clamping
- Precision cooling



A2

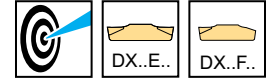
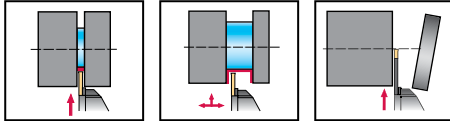

## Tool

		Designation	s mm	T <sub>max</sub> mm	h = h <sub>1</sub> mm	b mm	f <sub>1</sub> mm	l <sub>1</sub> mm	l <sub>4</sub> mm	s <sub>1</sub> mm	Type
		G4011-2020R-4T17DX18-P	4	17	20	20	18,3	125	33,5	3,4	DX18-4E4 .. DX18-4F4 ..
		G4011-2525R-4T17DX18-P		17	25	25	23,3	125	33,5	3,4	
		G4011-2020L-4T17DX18-P	4	17	20	20	18,3	125	33,5	3,4	DX18-4E4 .. DX18-4F4 ..
		G4011-2525L-4T17DX18-P		17	25	25	23,3	125	33,5	3,4	

Square shank

Dimensional drawing shows right-hand version. |  $f = f_1 + s/2$  |  $f_1 = f - s/2$  | If no  $D_{max}$  is specified, there is no diameter limit on the tool. | If no  $D_2$  or  $D_{max}$  is specified, there is no diameter limit on the tool. | The maximum recommended coolant pressure is 150 bar (2175 psi) | Refer to the Walter online catalogue for more product information: [www.walter-tools.com](http://www.walter-tools.com) | Bodies and assembly parts are included in the scope of delivery

## Assembly parts

		s [mm]	4
	Clamping screw for grooving insert Tightening torque		FS2118 (T20IP) 5 Nm
	G 1/8" threaded plug		FS2258 (SW 2)
	Allen key		FS1464 (T20IP)

## Accessories

		s [mm]	4
	Torque screwdriver, analogue		FS2003
	Torque screwdriver, digital		FS2248
	Interchangeable blade		FS2015 (T20IP)

# Shank tool – Radial grooving

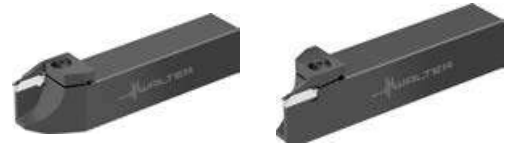
**G4011** inch
**Walter Cut**

– Screw clamping

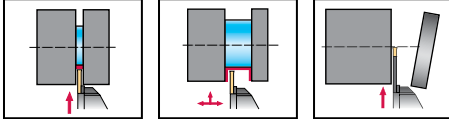

## Tool

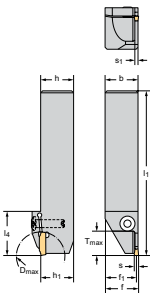

Designation	s inch	T <sub>max</sub> inch	D <sub>max</sub> inch	h = h <sub>1</sub> inch	b inch	f <sub>1</sub> inch	l <sub>1</sub> inch	l <sub>4</sub> inch	s <sub>1</sub> inch	Type
G4011.16R-3T17DX18	0,118	0,669	1,378	1,000	1,000	0,953	4,921	1,319	0,094	DX18-3E3 .. DX18-3F3 ..
G4011.16L-3T17DX18	0,118	0,669	1,378	1,000	1,000	0,953	4,921	1,319	0,094	DX18-3E3 .. DX18-3F3 ..

Square shank

Dimensional drawing shows right-hand version. |  $f_1 = f - s/2$  |  $f = f_1 + s/2$  | If no  $D_{max}$  is specified, there is no diameter limit on the tool. | Refer to the Walter online catalogue for more product information: [www.walter-tools.com](http://www.walter-tools.com) | Bodies and assembly parts are included in the scope of delivery

## Assembly parts

	s [inch]	0,118
	Clamping screw for grooving insert Tightening torque	FS2118 (T20IP) 3,688 lbs
	Allen key	FS1464 (T20IP)

## Accessories

	s [inch]	0,118
	Torque screwdriver, analogue	FS2004
	Torque screwdriver, digital	FS2248
	Interchangeable blade	FS2015 (T20IP)

## Shank tool – Radial grooving

G4011 inch

Walter Cut



– Screw clamping

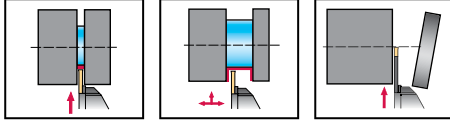

## Tool

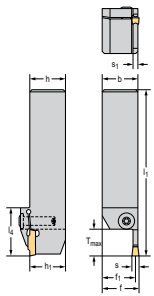



Square shank



Designation	s inch	T <sub>max</sub> inch	h = h <sub>1</sub> inch	b inch	f <sub>1</sub> inch	l <sub>1</sub> inch	l <sub>4</sub> inch	s <sub>1</sub> inch	Type
G4011.12R-2T10DX18	0,079	0,394	0,750	0,750	0,717	4,921	1,102	0,063	DX18-2E2 ..
G4011.16R-2T10DX18		0,394	1,000	1,000	0,969	4,921	1,102	0,063	
G4011.16R-3T10DX18	0,118	0,394	1,000	1,000	0,953	4,921	1,102	0,094	DX18-3E3 .. DX18-3F3 ..
G4011.12R-4T17DX18	0,157	0,669	0,750	0,750	0,685	4,921	1,319	0,134	DX18-4E4 .. DX18-4F4 ..
G4011.16R-4T17DX18		0,669	1,000	1,000	0,933	4,921	1,319	0,134	
G4011.16L-2T10DX18	0,079	0,394	1,000	1,000	0,969	4,921	1,102	0,063	DX18-2E2 ..
G4011.16L-3T10DX18	0,118	0,394	1,000	1,000	0,953	4,921	1,102	0,094	DX18-3E3 .. DX18-3F3 ..
G4011.12L-4T17DX18	0,157	0,669	0,750	0,750	0,685	4,921	1,319	0,134	DX18-4E4 .. DX18-4F4 ..
G4011.16L-4T17DX18		0,669	1,000	1,000	0,933	4,921	1,319	0,134	

Dimensional drawing shows right-hand version. |  $f_1 = f - s/2$  |  $f = f_1 + s/2$  | If no  $D_{max}$  is specified, there is no diameter limit on the tool. | If no  $D_2$  or  $D_{max}$  is specified, there is no diameter limit on the tool. | Refer to the Walter online catalogue for more product information: [www.walter-tools.com](http://www.walter-tools.com) | Bodies and assembly parts are included in the scope of delivery

## Assembly parts

	s [inch]	0,079–0,157
	Clamping screw for grooving insert Tightening torque	FS2118 (T20IP) 3,688 lbs
	Allen key	FS1464 (T20IP)

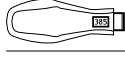
## Accessories

	s [inch]	0,079–0,157
	Torque screwdriver, analogue	FS2004
	Torque screwdriver, digital	FS2248
	Interchangeable blade	FS2015 (T20IP)

# Shank tool – Radial grooving

**G4011...-P**    **inch**

## Walter Cut

- Screw clamping
- Precision cooling

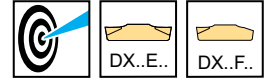
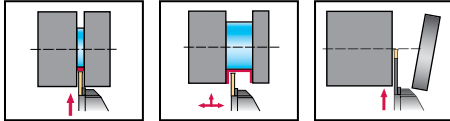
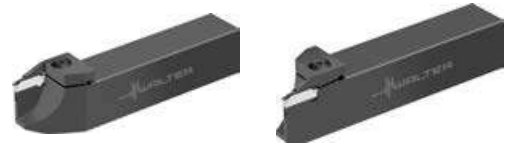

### Tool

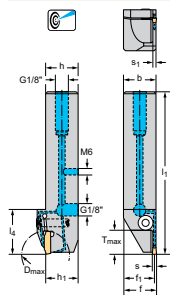

Designation	s inch	T <sub>max</sub> inch	D <sub>max</sub> inch	h = h <sub>1</sub> inch	b inch	f <sub>1</sub> inch	l <sub>1</sub> inch	l <sub>2</sub> inch	s <sub>1</sub> inch	Type
G4011.16R-2T17DX18-P	0,079	0,669	1,378	1,000	1,000	0,969	4,921	1,319	0,063	DX18-2E2 ..
G4011.16R-3T17DX18-P	0,118	0,669	1,378	1,000	1,000	0,953	4,921	1,319	0,094	DX18-3E3 .. DX18-3F3 ..
G4011.16L-2T17DX18-P	0,079	0,669	1,378	1,000	1,000	0,969	4,921	1,319	0,063	DX18-2E2 ..
G4011.16L-3T17DX18-P	0,118	0,669	1,378	1,000	1,000	0,953	4,921	1,319	0,094	DX18-3E3 .. DX18-3F3 ..

Square shank

Dimensional drawing shows right-hand version. |  $f_1 = f - s/2$  | If no  $D_{max}$  is specified, there is no diameter limit on the tool. | The maximum recommended coolant pressure is 150 bar (2175 psi) | Refer to the Walter online catalogue for more product information: [www.walter-tools.com](http://www.walter-tools.com) | Bodies and assembly parts are included in the scope of delivery

### Assembly parts

	s [inch]	0,079–0,118
	Clamping screw for grooving insert Tightening torque	FS2118 (T20IP) 3,688 lbs
	G 1/8" threaded plug	FS2258 (SW 2)
	M6 threaded plug	FS2288 (SW 3)
	Allen key	FS1464 (T20IP)

### Accessories

	s [inch]	0,079–0,118
	Torque screwdriver, analogue	FS2004
	Torque screwdriver, digital	FS2248
	Interchangeable blade	FS2015 (T20IP)

## Shank tool – Universal

G4511 

## Walter Cut

- Screw clamping
- Different grooving widths fit in one tool

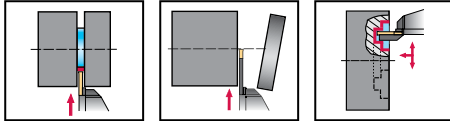

## Tool

	Designation	s mm	T <sub>max</sub> mm	h = h <sub>1</sub> mm	b mm	f <sub>1</sub> mm	l <sub>1</sub> mm	l <sub>4</sub> mm	Type
	G4511-1212R-T5DX18	2 - 6	5	12	12	9,4	120	31,5	DX18- . E .. DX18- . F ..
	G4511-1616R-T5DX18		5	16	16	13,4	120	29	
	G4511-2020R-T5DX18		5	20	20	17,4	120	29	
	G4511-2525R-T5DX18		5	25	25	22,4	125	29	
	G4511-2020L-T5DX18	2 - 6	5	20	20	17,4	120	29	DX18- . E .. DX18- . F ..
	G4511-2525L-T5DX18		5	25	25	22,4	125	29	

Square shank

Dimensional drawing shows right-hand version.  $l = f_1 + s/2$  | Refer to the Walter online catalogue for more product information: [www.walter-tools.com](http://www.walter-tools.com) | Bodies and assembly parts are included in the scope of delivery

## Assembly parts

	s [mm]	2 - 6
	Clamping screw for grooving insert Tightening torque	FS2118 (T20IP) 5 Nm
	Allen key	FS1464 (T20IP)

## Accessories

	s [mm]	2 - 6
	Torque screwdriver, analogue	FS2003
	Torque screwdriver, digital	FS2248
	Interchangeable blade	FS2015 (T20IP)

# Shank tool – 90° universal

**G4521** 

## Walter Cut

- Screw clamping
- Different grooving widths fit in one tool

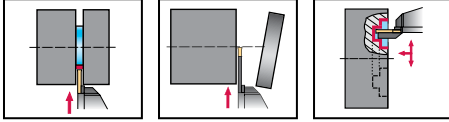
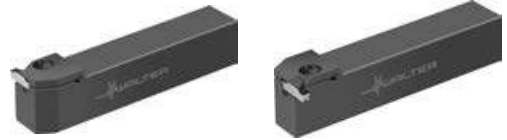

### Tool

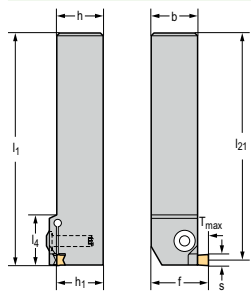

Designation	s mm	T <sub>max</sub> mm	h = h <sub>1</sub> mm	b mm	f mm	l <sub>4</sub> mm	l <sub>21</sub> mm	Type
G4521-2020R-T5DX18	2 - 6	5	20	20	25,5	27	117,4	DX18- . E .. DX18- . F ..
G4521-2525R-T5DX18		5	25	25	30,5	27	122,4	
G4521-2020L-T5DX18	2 - 6	5	20	20	25,5	27	117,4	DX18- . E .. DX18- . F ..
G4521-2525L-T5DX18		5	25	25	30,5	27	122,4	

Square shank

 Dimensional drawing shows right-hand version. |  $l_1 = l_{21} + s/2$  | Refer to the Walter online catalogue for more product information: [www.walter-tools.com](http://www.walter-tools.com) | Bodies and assembly parts are included in the scope of delivery

### Assembly parts

	s [mm]	2 - 6
	Clamping screw for grooving insert Tightening torque	FS2118 (T20IP) 5 Nm
	Allen key	FS1464 (T20IP)

### Accessories

	s [mm]	2 - 6
	Torque screwdriver, analogue	FS2003
	Torque screwdriver, digital	FS2248
	Interchangeable blade	FS2015 (T20IP)

## Shank tool – 45° universal

G4551 

## Walter Cut

- Screw clamping
- Different grooving widths fit in one tool



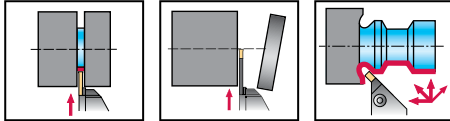

A2

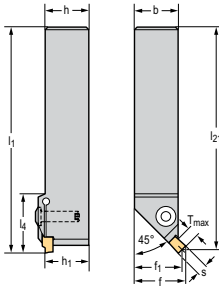



Tool		s mm	T <sub>max</sub> mm	h = h <sub>1</sub> mm	b mm	f <sub>1</sub> mm	l <sub>21</sub> mm	l <sub>4</sub> mm	Type
	Designation								
	G4551-2020R-T5DX18	2 - 6	5	20	20	22,3	127,5	32	DX18- . E .. DX18- . F ..
	G4551-2525R-T5DX18		5	25	25	27,3	127,5	32	
	G4551-2525L-T5DX18	2 - 6	5	25	25	27,3	127,5	32	DX18- . E .. DX18- . F ..

Square shank

Dimensional drawing shows right-hand version.  $l = f_1 + 0.707 \times s/2$  |  $l_1 = l_{21} + 0.707 \times s/2$  | Refer to the Walter online catalogue for more product information: [www.walter-tools.com](http://www.walter-tools.com) | Bodies and assembly parts are included in the scope of delivery

Assembly parts		s [mm]	2 - 6
	Clamping screw for grooving insert Tightening torque		FS2118 (T20IP) 5 Nm
	Allen key		FS1464 (T20IP)

Accessories		s [mm]	2 - 6
	Torque screwdriver, analogue		FS2003
	Torque screwdriver, digital		FS2248
	Interchangeable blade		FS2015 (T20IP)

# Deep parting blade

 G4042...N 

## Walter Cut



– Self-clamping system

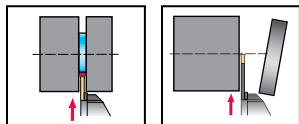

### Tool

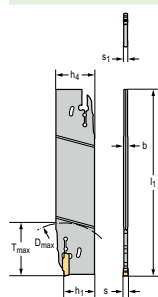

Designation	s mm	T <sub>max</sub> mm	D <sub>max</sub> mm	h <sub>2</sub> mm	b mm	l <sub>1</sub> mm	h <sub>1</sub> mm	s <sub>1</sub> mm	Type
G4042-26N-1.5T17DX18	1,5	17	35	26	3,5	130	17,4	1,2	DX18-1E1.5 ..
G4042-26N-2T25DX18	2	25	50	26	3,5	130	17,4	1,6	DX18-2E2 ..
G4042-26N-3T40DX18	3	40	80	26	3,5	130	17,3	2,4	DX18-3E3 .. DX18-3F3 ..
G4042-26N-4T40DX18	4	40	80	26	3,5	130	17,2	3,4	DX18-4E4 .. DX18-4F4 ..
G4042-32N-1.5T17DX18	1,5	17	35	32	3,5	150	21,1	1,2	DX18-1E1.5 ..
G4042-32N-2T25DX18	2	25	50	32	3,5	150	21,1	1,6	DX18-2E2 ..
G4042-32N-3T40DX18	3	40	80	32	3,5	150	21	2,4	DX18-3E3 .. DX18-3F3 ..
G4042-32N-4T40DX18	4	40	80	32	3,5	150	20,9	3,4	DX18-4E4 .. DX18-4F4 ..

 Refer to the Walter online catalogue for more product information: [www.walter-tools.com](http://www.walter-tools.com)

### Accessories

	s [mm]	1,5–4
	Mounting wrench for grooving insert	FS1494



## Deep parting blade

G4042...N...-P

### Walter Cut

- Self-clamping system
- Precision cooling



A2

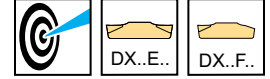
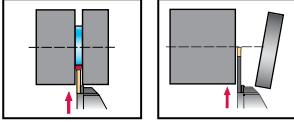

### Tool

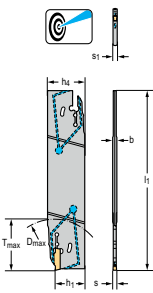
	Designation	s mm	T <sub>max</sub> mm	D <sub>max</sub> mm	h <sub>4</sub> mm	b mm	l <sub>1</sub> mm	h <sub>1</sub> mm	s <sub>1</sub> mm	Type
	G4042-26N-3T40DX18-P	3	40	80	26	3,5	130	17,3	2,4	DX18-3E3 .. DX18-3F3 ..
	G4042-32N-3T40DX18-P	3	40	80	32	3,5	150	21	2,4	DX18-3E3 .. DX18-3F3 ..

Refer to the Walter online catalogue for more product information: [www.walter-tools.com](http://www.walter-tools.com) | Bodies and assembly parts are included in the scope of delivery

### Assembly parts

	s [mm]	
		3
Coolant transfer insert		FS2282

### Accessories

	s [mm]	
		3
Mounting wrench for grooving insert		FS1494

# Reinforced parting blade

**G4041** 

## Walter Cut



– Screw clamping

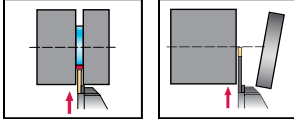

### Tool

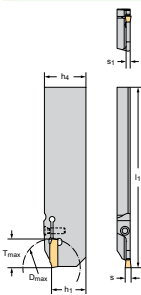

Designation	s mm	T <sub>max</sub> mm	D <sub>max</sub> mm	h <sub>4</sub> mm	l <sub>1</sub> mm	h <sub>1</sub> mm	s <sub>1</sub> mm	Type
G4041-26R-1.5T17DX18	1,5	17	35	26	110	21,3	1,2	DX18-1E1.5 ..
G4041-26R-2T17DX18	2	17	35	26	110	21,3	1,6	DX18-2E2 ..
G4041-32R-2T21DX18		21	42	32	110	25	2,5	
G4041-26R-3T17DX18	3	17	35	26	110	21,3	2,5	DX18-3E3 .. DX18-3F3 ..
G4041-26L-1.5T17DX18	1,5	17	35	26	110	21,3	1,2	DX18-1E1.5 ..
G4041-26L-2T17DX18	2	17	35	26	110	21,3	1,6	DX18-2E2 ..
G4041-26L-3T17DX18	3	17	35	26	110	21,3	2,5	DX18-3E3 .. DX18-3F3 ..

Dimensional drawing shows right-hand version. | Refer to the Walter online catalogue for more product information: [www.walter-tools.com](http://www.walter-tools.com) | Bodies and assembly parts are included in the scope of delivery

### Assembly parts

	s [mm]	1,5-3
	Clamping screw for grooving insert Tightening torque	FS2164 (T15IP) 3,5 Nm

### Accessories

	s [mm]	1,5-3
	Screwdriver for grooving insert	FS1485 (T15IP)
	Torque screwdriver, analogue	FS2003
	Torque screwdriver, digital	FS2248
	Interchangeable blade	FS2014 (T15IP)

## Reinforced parting blade

G4041...-P 

## Walter Cut

- Screw clamping
- Precision cooling

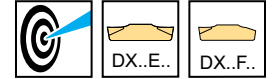
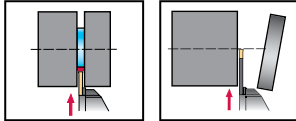

## Tool

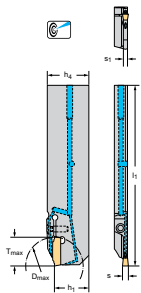

Designation	s mm	T <sub>max</sub> mm	D <sub>max</sub> mm	h <sub>4</sub> mm	l <sub>1</sub> mm	h <sub>1</sub> mm	s <sub>1</sub> mm	Type
G4041-26R-2T17DX18-P	2	17	35	26	110	21,3	1,6	DX18-2E2 ..
G4041-26R-3T17DX18-P	3	17	35	26	110	21,3	2,5	DX18-3E3 .. DX18-3F3 ..
G4041-26L-2T17DX18-P	2	17	35	26	110	21,3	1,6	DX18-2E2 ..
G4041-32L-2T21DX18-P		21	42	32	110	25	1,6	
G4041-26L-3T17DX18-P	3	17	35	26	110	21,3	2,5	DX18-3E3 .. DX18-3F3 ..

Dimensional drawing shows right-hand version. | The maximum recommended coolant pressure is 80 bar (1160 psi) | Refer to the Walter online catalogue for more product information: [www.walter-tools.com](http://www.walter-tools.com) | Bodies and assembly parts are included in the scope of delivery

## Assembly parts

	s [mm]	2-3
Clamping screw for grooving insert Tightening torque		FS2164 (T15IP) 3,5 Nm

## Accessories

	s [mm]	2-3
Screwdriver for grooving insert		FS1485 (T15IP)
Torque screwdriver, analogue		FS2003
Torque screwdriver, digital		FS2248
Interchangeable blade		FS2014 (T15IP)

# Reinforced parting blade – Contra

G4041...C

## Walter Cut



– Screw clamping

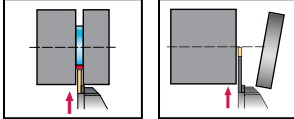

### Tool

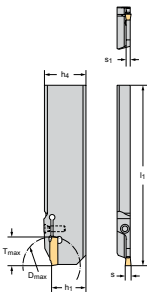

Designation	s mm	T <sub>max</sub> mm	D <sub>max</sub> mm	h <sub>4</sub> mm	h <sub>1</sub> mm	h <sub>1</sub> mm	s <sub>1</sub> mm	Type
G4041-26R-1.5T17DX18C	1,5	17	35	26	110	21,3	1,2	DX18-1E1.5 ..
G4041-26R-2T17DX18C	2	17	35	26	110	21,3	1,6	DX18-2E2 ..
G4041-32R-2T21DX18C		21	42	32	110	25	1,6	
G4041-26R-3T17DX18C	3	17	35	26	110	21,3	2,5	DX18-3E3 .. DX18-3F3 ..
G4041-26L-1.5T17DX18C	1,5	17	35	26	110	21,3	1,2	DX18-1E1.5 ..
G4041-26L-2T17DX18C	2	17	35	26	110	21,3	1,6	DX18-2E2 ..
G4041-32L-2T21DX18C		21	42	32	110	25	1,6	
G4041-26L-3T17DX18C	3	17	35	26	110	21,3	2,5	DX18-3E3 .. DX18-3F3 ..

Dimensional drawing shows right-hand version. | Refer to the Walter online catalogue for more product information: [www.walter-tools.com](http://www.walter-tools.com) | Bodies and assembly parts are included in the scope of delivery

### Assembly parts

	s (mm)	1,5–3
	Clamping screw for grooving insert Tightening torque	FS2164 (T15IP) 3,5 Nm

### Accessories

	s (mm)	1,5–3
	Screwdriver for grooving insert	FS1485 (T15IP)
	Torque screwdriver, analogue	FS2003
	Torque screwdriver, digital	FS2248
	Interchangeable blade	FS2014 (T15IP)

## Reinforced parting blade – Contra

G4041...C-P 

## Walter Cut

- Screw clamping
- Precision cooling



A2

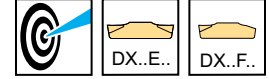
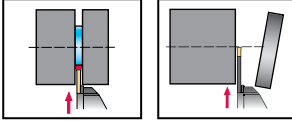

## Tool

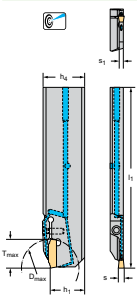

Designation	s mm	T <sub>max</sub> mm	D <sub>max</sub> mm	h <sub>4</sub> mm	l <sub>1</sub> mm	h <sub>1</sub> mm	s <sub>1</sub> mm	Type
G4041-26R-2T17DX18C-P	2	17	35	26	110	21,3	1,6	DX18-2E2 ..
G4041-32R-2T21DX18C-P		21	42	32	110	21,3	1,6	
G4041-26R-3T17DX18C-P	3	17	35	26	110	21,3	2,5	DX18-3E3 .. DX18-3F3 ..
G4041-32R-3T21DX18C-P		21	42	32	110	21,3	2,5	
G4041-26L-2T17DX18C-P	2	17	35	26	110	21,3	1,6	DX18-2E2 ..
G4041-32L-2T21DX18C-P		21	42	32	110	21,3	1,6	
G4041-26L-3T17DX18C-P	3	17	35	26	110	21,3	2,5	DX18-3E3 .. DX18-3F3 ..
G4041-32L-3T21DX18C-P		21	42	32	110	21,3	2,5	

Dimensional drawing shows right-hand version. | The maximum recommended coolant pressure is 80 bar (1160 psi) | Refer to the Walter online catalogue for more product information: [www.walter-tools.com](http://www.walter-tools.com) | Bodies and assembly parts are included in the scope of delivery

## Assembly parts

	s [mm]	2-3
	Clamping screw for grooving insert Tightening torque	FS2164 (T15IP) 3,5 Nm

## Accessories

	s [mm]	2-3
	Screwdriver for grooving insert	FS1485 (T15IP)
	Torque screwdriver, analogue	FS2003
	Torque screwdriver, digital	FS2248
	Interchangeable blade	FS2014 (T15IP)

# Grooving module – Radial grooving

**G4635** 

## Walter Cut

- Screw clamping
- Replacement module

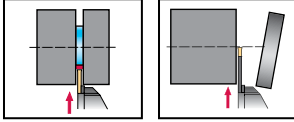

### Tool

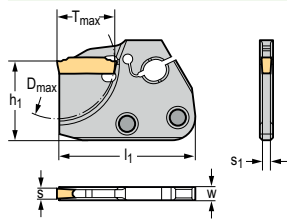

Designation	s mm	T <sub>max</sub> mm	D <sub>max</sub> mm	h <sub>1</sub> mm	W mm	l <sub>1</sub> mm	s <sub>1</sub> mm	Module size	Type
G4635-30N-1.5T10DX18	1,5	10	35	24	4	42	1,2	E30	DX18-1E1.5 ..
G4635-30N-2T17DX18	2	17	35	24	4	42	1,6	E30	DX18-2E2 ..
G4635-30N-3T17DX18	3	17	35	24	4	42	2,4	E30	DX18-3E3 .. DX18-3F3 ..

 Refer to the Walter online catalogue for more product information: [www.walter-tools.com](http://www.walter-tools.com)

# Grooving module – Radial grooving

G4635-P

## Walter Cut

- Screw clamping
- Replacement module

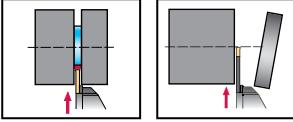

### Tool

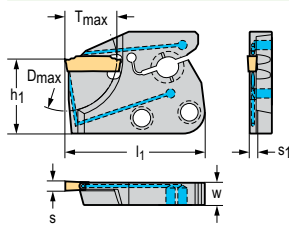

Designation	s mm	T <sub>max</sub> mm	D <sub>max</sub> mm	h <sub>1</sub> mm	W mm	l <sub>1</sub> mm	s <sub>1</sub> mm	Module size	Type
G4635-33L-2T16DX18-P	2	16	32	24	7,2	45	1,6	E33	DX18-2E2 ..
G4635-33L-2.5T16DX18-P	2,5	16	32	24	7,2	45	2,1	E33	DX18-2E2.5 ..

The maximum recommended coolant pressure is 150 bar (2175 psi) | Refer to the Walter online catalogue for more product information: [www.walter-tools.com](http://www.walter-tools.com)

# Grooving module – Radial grooving

**G4634-P** mm

## Walter Cut

- Screw clamping
- Replacement module

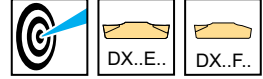
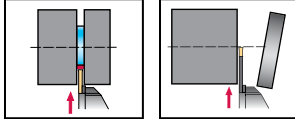

### Tool

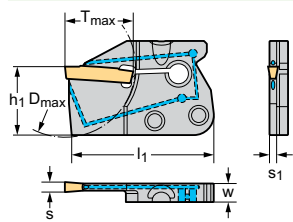

Designation	s mm	T <sub>max</sub> mm	D <sub>max</sub> mm	h <sub>1</sub> mm	W mm	l <sub>1</sub> mm	s <sub>1</sub> mm	Module size	Type
G4634-33L-2T13DX18-P	2	13	26	24	4	36	1,6	E33	DX18-2E2 ..
G4634-33L-2T16DX18-P		16	32	24	7,2	46	1,6	E33	
G4634-33L-3T16DX18-P	3	16	32	24	7,2	46	2,4	E33	DX18-3E3 .. DX18-3F3 ..

If no  $D_2$  or  $D_{max}$  is specified, there is no diameter limit on the tool. | The maximum recommended coolant pressure is 150 bar (2175 psi) | If a clamping wedge is used, please use screw FS2622 | Refer to the Walter online catalogue for more product information: [www.walter-tools.com](http://www.walter-tools.com)



## Shank tool – Radial grooving

G5011 

## Groov-tec™ GD



– Screw clamping

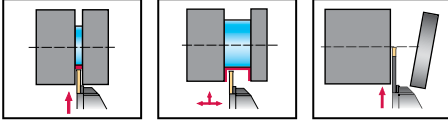

## Tool

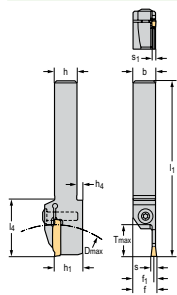

Designation	s mm	T <sub>max</sub> mm	D <sub>max</sub> mm	h = h <sub>1</sub> mm	b mm	f <sub>1</sub> mm	l <sub>1</sub> mm	h <sub>4</sub> mm	l <sub>4</sub> mm	s <sub>1</sub> mm	Type
★ G5011-1616R-3T21GD26	3	21	120	16	16	14,8	150	4	40	2,4	GD26-3 ..
★ G5011-1616L-3T21GD26	3	21	120	16	16	14,8	150	4	40	2,4	GD26-3 ..



Square shank

Dimensional drawing shows right-hand version. |  $f = f_1 + s/2$  |  $f_1 = f - s/2$  | Refer to the Walter online catalogue for more product information: [www.walter-tools.com](http://www.walter-tools.com) | Bodies and assembly parts are included in the scope of delivery

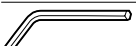
## Assembly parts

	s [mm]	3
	Clamping screw for grooving insert Tightening torque	FS2118 (T20IP) 5 Nm
	Allen key	FS1464 (T20IP)

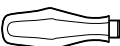
## Accessories

	s [mm]	3
	Torque screwdriver, analogue	FS2003
	Torque screwdriver, digital	FS2248
	Interchangeable blade	FS2015 (T20IP)

# Shank tool – Radial grooving

G5011

## Groov-tec™ GD



– Screw clamping

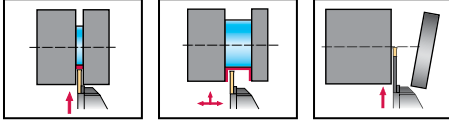

### Tool

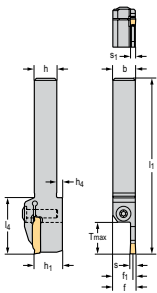

Designation	s mm	T <sub>max</sub> mm	h = h <sub>1</sub> mm	b mm	f <sub>1</sub> mm	l <sub>1</sub> mm	h <sub>4</sub> mm	l <sub>4</sub> mm	s <sub>1</sub> mm	Type
★ G5011-1616R-4T21GD26	4	21	16	16	14,3	150	4	40	3,4	GD26-4 ..

Square shank

$f = f_1 + s/2$  |  $f_1 = f - s/2$  | Refer to the Walter online catalogue for more product information: [www.walter-tools.com](http://www.walter-tools.com) | Bodies and assembly parts are included in the scope of delivery

### Assembly parts

	s [mm]	4
	Clamping screw for grooving insert Tightening torque	FS2118 (T20IP) 5 Nm
	Allen key	FS1464 (T20IP)

### Accessories

	s [mm]	4
	Torque screwdriver, analogue	FS2003
	Torque screwdriver, digital	FS2248
	Interchangeable blade	FS2015 (T20IP)

## Shank tool – Radial grooving

G5011 

## Groov-tec™ GD



A2

– Screw clamping

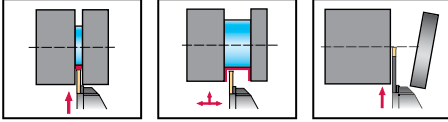

## Tool

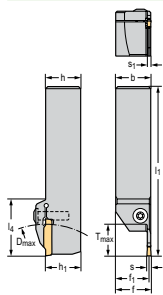

Designation	s mm	T <sub>max</sub> mm	D <sub>max</sub> mm	h = h <sub>1</sub> mm	b mm	f <sub>1</sub> mm	l <sub>1</sub> mm	l <sub>4</sub> mm	s <sub>1</sub> mm	Type
★ G5011-2012R-3T21GD26	3	21	120	20	12	10,8	145	40	2,4	GD26-3 ..
★ G5011-2020R-3T21GD26		21	120	20	20	18,8	150	40	2,4	
★ G5011-2525R-3T21GD26		21	120	25	25	23,8	150	40	2,4	
★ G5011-2012L-3T21GD26	3	21	120	20	12	10,8	145	40	2,4	GD26-3 ..
★ G5011-2020L-3T21GD26		21	120	20	20	18,8	150	40	2,4	
★ G5011-2525L-3T21GD26		21	120	25	25	23,8	150	40	2,4	

Square shank

Dimensional drawing shows right-hand version. |  $f = f_1 + s/2$  |  $f_1 = f - s/2$  | Refer to the Walter online catalogue for more product information: [www.walter-tools.com](http://www.walter-tools.com) | Bodies and assembly parts are included in the scope of delivery

## Assembly parts

	s [mm] b [mm]	3 12	3 20-25
	Clamping screw for grooving insert Tightening torque	FS1473 (T15IP) 3,9 Nm	FS2118 (T20IP) 5 Nm
	Torx key	FS1465 (T15IP)	
	Allen key		FS1464 (T20IP)

## Accessories

	s [mm] b [mm]	3 12	3 20-25
	Torque screwdriver, analogue	FS2003	FS2003
	Torque screwdriver, digital	FS2248	FS2248
	Interchangeable blade	FS2014 (T15IP)	FS2015 (T20IP)

# Shank tool – Radial grooving

**G5011** 
**Groov-tec™ GD**

– Screw clamping

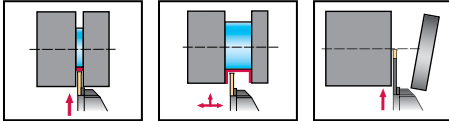
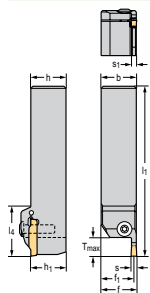
**Tool**

Square shank

Designation	s mm	T <sub>max</sub> mm	h = h <sub>1</sub> mm	b mm	f <sub>1</sub> mm	l <sub>1</sub> mm	l <sub>4</sub> mm	s <sub>1</sub> mm	Type
★ G5011-2020R-3T12GD26	3	12	20	20	18,8	145	35	2,4	GD26-3 ..
★ G5011-2525R-3T12GD26		12	25	25	23,8	145	35	2,4	
★ G5011-2020R-4T12GD26	4	12	20	20	18,3	145	35	3,4	GD26-4 ..
★ G5011-2020R-4T21GD26		21	20	20	18,3	150	40	3,4	
★ G5011-2525R-4T12GD26		12	25	25	23,3	145	35	3,4	
★ G5011-2525R-4T21GD26	5	21	25	25	23,3	150	40	3,4	GD26-5 ..
★ G5011-2020R-5T21GD26		12	20	20	17,9	150	40	4,2	
★ G5011-2525R-5T12GD26	6	12	25	25	22,9	145	35	4,2	GD26-6 ..
★ G5011-2525R-5T21GD26		21	25	25	22,9	150	40	4,2	
★ G5011-2020R-6T21GD26		21	20	20	17,4	150	40	5,2	
★ G5011-2020L-3T12GD26	3	12	20	20	18,8	145	35	2,4	GD26-3 ..
★ G5011-2525L-3T12GD26		12	25	25	23,8	145	35	2,4	
★ G5011-2020L-4T12GD26	4	12	20	20	18,3	145	35	3,4	GD26-4 ..
★ G5011-2020L-4T21GD26		21	20	20	18,3	150	40	3,4	
★ G5011-2525L-4T12GD26		12	25	25	23,3	145	35	3,4	
★ G5011-2525L-4T21GD26	5	21	25	25	23,3	150	40	3,4	GD26-5 ..
★ G5011-2020L-5T21GD26		12	20	20	17,9	150	40	4,2	
★ G5011-2525L-5T12GD26	6	12	25	25	22,9	145	35	4,2	GD26-6 ..
★ G5011-2525L-5T21GD26		21	25	25	22,9	150	40	4,2	
★ G5011-2020L-6T21GD26		21	20	20	17,4	150	40	5,2	
★ G5011-2525L-6T12GD26	3	12	20	20	18,8	145	35	2,4	GD26-3 ..
★ G5011-2525L-6T21GD26		12	25	25	23,8	145	35	2,4	
★ G5011-2020L-4T12GD26	4	12	20	20	18,3	145	35	3,4	GD26-4 ..
★ G5011-2020L-4T21GD26		21	20	20	18,3	150	40	3,4	
★ G5011-2525L-4T12GD26		12	25	25	23,3	145	35	3,4	
★ G5011-2525L-4T21GD26	5	21	25	25	23,3	150	40	3,4	GD26-5 ..
★ G5011-2020L-5T21GD26		12	20	20	17,9	150	40	4,2	
★ G5011-2525L-5T12GD26	6	12	25	25	22,9	145	35	4,2	GD26-6 ..
★ G5011-2525L-5T21GD26		21	25	25	22,9	150	40	4,2	
★ G5011-2020L-6T21GD26		21	20	20	17,4	150	40	5,2	

 Dimensional drawing shows right-hand version.  $l = f_1 + s/2$  |  $f_1 = f - s/2$  | Refer to the Walter online catalogue for more product information: [www.walter-tools.com](http://www.walter-tools.com) | Bodies and assembly parts are included in the scope of delivery

**Assembly parts**

	s [mm]	3–6
	Clamping screw for grooving insert Tightening torque	FS2118 (T20IP) 5 Nm
	Allen key	FS1464 (T20IP)

**Accessories**

	s [mm]	3–6
	Torque screwdriver, analogue	FS2003
	Torque screwdriver, digital	FS2248
	Interchangeable blade	FS2015 (T20IP)

## Shank tool – Radial grooving

G5011...-P 

## Groov-tec™ GD

- Screw clamping
- Precision cooling

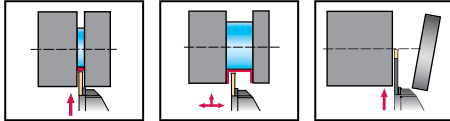

## Tool

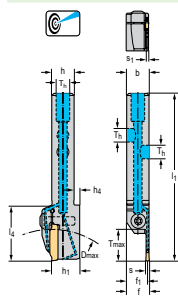

Designation	s mm	T <sub>max</sub> mm	D <sub>max</sub> mm	h = h <sub>1</sub> mm	b mm	f <sub>1</sub> mm	l <sub>1</sub> mm	h <sub>4</sub> mm	l <sub>4</sub> mm	s <sub>1</sub> mm	T <sub>h</sub>	Type
★ G5011-1616R-2.5T21GD26-P	2,5	21	120	16	16	15	120	4	40	2,1	G1/8"	GD26-2.5 ..
★ G5011-1616L-2.5T21GD26-P	2,5	21	120	16	16	15	120	4	40	2,1	G1/8"	GD26-2.5 ..

Square shank

Dimensional drawing shows right-hand version. |  $f = f_1 + s/2$  |  $f_1 = f - s/2$  | The maximum recommended coolant pressure is 150 bar (2175 psi) | Refer to the Walter online catalogue for more product information: [www.walter-tools.com](http://www.walter-tools.com) | Bodies and assembly parts are included in the scope of delivery

## Assembly parts

	s [mm]	2,5
	Clamping screw for grooving insert Tightening torque	FS2118 (T20IP) 5 Nm
	G 1/8" threaded plug	FS2258 (SW 2)
	Allen key	FS1464 (T20IP)

## Accessories

	s [mm]	2,5
	Torque screwdriver, analogue	FS2003
	Torque screwdriver, digital	FS2248
	Interchangeable blade	FS2015 (T20IP)

# Shank tool – Radial grooving

 G5011...-P 

## Groov-tec™ GD

- Screw clamping
- Precision cooling

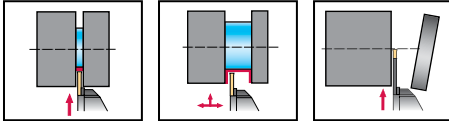

### Tool

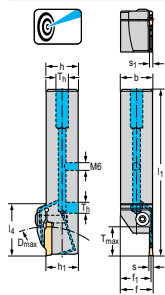

Designation	s mm	T <sub>max</sub> mm	D <sub>max</sub> mm	h = h <sub>1</sub> mm	b mm	f <sub>1</sub> mm	l <sub>1</sub> mm	l <sub>4</sub> mm	s <sub>1</sub> mm	T <sub>h</sub>	Type
★ G5011-2020R-3T21GD26-P	3	21	120	20	20	18,8	125	40	2,4	G1/8"	GD26-3 ..
★ G5011-2525R-3T21GD26-P		21	120	25	25	23,8	130	40	2,4	G1/8"	
★ G5011-2020L-3T21GD26-P	3	21	120	20	20	18,8	125	40	2,4	G1/8"	GD26-3 ..
★ G5011-2525L-3T21GD26-P		21	120	25	25	23,8	130	40	2,4	G1/8"	

Square shank

Dimensional drawing shows right-hand version. |  $f = f_1 + s/2$  |  $f_1 = f - s/2$  | The maximum recommended coolant pressure is 150 bar (2175 psi) | Refer to the Walter online catalogue for more product information: [www.walter-tools.com](http://www.walter-tools.com) | Bodies and assembly parts are included in the scope of delivery

### Assembly parts

	s [mm]	
		Clamping screw for grooving insert Tightening torque
	3	FS2118 (T20IP) 5 Nm
		G 1/8" threaded plug
		FS2258 (SW 2)
		Allen key
		FS1464 (T20IP)

### Accessories

	s [mm]	
		Torque screwdriver, analogue
	3	FS2003
		Torque screwdriver, digital
		FS2248
		Interchangeable blade
		FS2015 (T20IP)

## Shank tool – Radial grooving

G5011...-P 

## Groov-tec™ GD

- Screw clamping
- Precision cooling

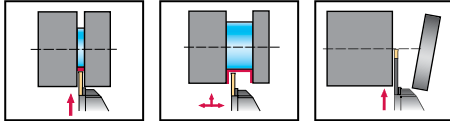

## Tool

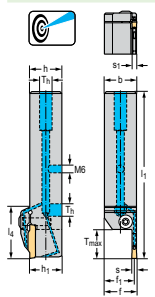

Designation	s mm	T <sub>max</sub> mm	h = h <sub>1</sub> mm	b mm	f <sub>1</sub> mm	l <sub>1</sub> mm	l <sub>2</sub> mm	s <sub>1</sub> mm	T <sub>h</sub>	Type
★ G5011-2020R-4T21GD26-P	4	21	20	20	18,3	125	40	3,4	G1/8"	GD26-4 ..
★ G5011-2525R-4T21GD26-P		21	25	25	23,3	130	40	3,4	G1/8"	
★ G5011-2020R-5T12GD26-P	5	12	20	20	17,9	120	35	4,2	G1/8"	GD26-5 ..
★ G5011-2525R-6T12GD26-P	6	12	25	25	22,4	125	35	5,2	G1/8"	GD26-6 ..
★ G5011-2020L-4T21GD26-P	4	21	20	20	18,3	125	40	3,4	G1/8"	GD26-4 ..
★ G5011-2525L-4T21GD26-P		21	25	25	23,3	130	40	3,4	G1/8"	
★ G5011-2020L-5T12GD26-P	5	12	20	20	17,9	120	35	4,2	G1/8"	GD26-5 ..

Square shank

Dimensional drawing shows right-hand version. |  $f = f_1 + s/2$  |  $f_1 = f - s/2$  | The maximum recommended coolant pressure is 150 bar (2175 psi) | Refer to the Walter online catalogue for more product information: [www.walter-tools.com](http://www.walter-tools.com) | Bodies and assembly parts are included in the scope of delivery

## Assembly parts

	s [mm]	4–6
	Clamping screw for grooving insert Tightening torque	FS2118 (T20IP) 5 Nm
	G 1/8" threaded plug	FS2258 (SW 2)
	Allen key	FS1464 (T20IP)

## Accessories

	s [mm]	4–6
	Torque screwdriver, analogue	FS2003
	Torque screwdriver, digital	FS2248
	Interchangeable blade	FS2015 (T20IP)

A2

## Shank tool – Radial grooving

 G5011 inch
**Groov-tec™ GD**

– Screw clamping

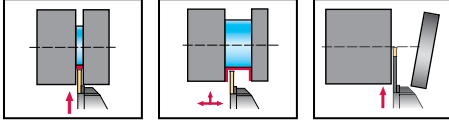
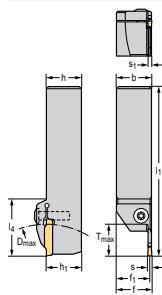
**Tool**

Designation	s inch	T <sub>max</sub> inch	D <sub>max</sub> inch	h = h <sub>1</sub> inch	b inch	f <sub>1</sub> inch	l <sub>1</sub> inch	l <sub>4</sub> inch	s <sub>1</sub> inch	Type
★ G5011.10R-3T21GD26	0,118	0,827	4,724	0,625	0,625	0,578	5,315	1,575	0,094	GD26-3 ..
★ G5011.12R-3T21GD26		0,827	4,724	0,750	0,750	0,703	5,906	1,575	0,094	
★ G5011.16R-3T21GD26		0,827	4,724	1,000	1,000	0,953	5,906	1,575	0,094	
★ G5011.10L-3T21GD26	0,118	0,827	4,724	0,625	0,625	0,578	5,315	1,575	0,094	GD26-3 ..
★ G5011.12L-3T21GD26		0,827	4,724	0,750	0,750	0,703	5,906	1,575	0,094	
★ G5011.16L-3T21GD26		0,827	4,724	1,000	1,000	0,953	5,906	1,575	0,094	

Square shank

 Dimensional drawing shows right-hand version. |  $f = f_1 + s/2$  |  $f_1 = f - s/2$  | Refer to the Walter online catalogue for more product information: [www.walter-tools.com](http://www.walter-tools.com) | Bodies and assembly parts are included in the scope of delivery

**Assembly parts**

	s [inch]	0,118
	Clamping screw for grooving insert Tightening torque	FS2118 (T20IP) 3,688 lbs
	Allen key	FS1464 (T20IP)

**Accessories**

	s [inch]	0,118
	Torque screwdriver, analogue	FS2004
	Torque screwdriver, digital	FS2248
	Interchangeable blade	FS2015 (T20IP)



## Shank tool – Radial grooving

G5011 inch

Groov-tec™ GD



A2

– Screw clamping

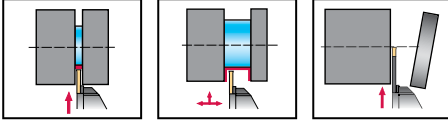

## Tool

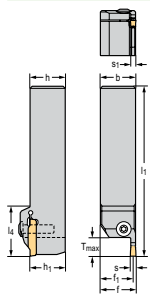

Designation	s inch	T <sub>max</sub> inch	h = h <sub>1</sub> inch	b inch	f <sub>1</sub> inch	l <sub>1</sub> inch	l <sub>4</sub> inch	s <sub>1</sub> inch	Type
★ G5011.12R-3T12GD26	0,118	0,472	0,750	0,750	0,703	5,709	1,378	0,094	GD26-3 ..
★ G5011.16R-3T12GD26			1,000	1,000	0,953	5,709	1,378	0,094	
★ G5011.12R-4T21GD26	0,157	0,827	0,750	0,750	0,683	5,906	1,575	0,134	GD26-4 ..
★ G5011.16R-4T21GD26			1,000	1,000	0,933	5,709	1,378	0,134	
★ G5011.16R-4T21GD26			1,000	1,000	0,933	5,906	1,575	0,134	
★ G5011.12L-4T21GD26	0,157	0,827	0,750		0,683	5,906	1,575	0,134	GD26-4 ..
★ G5011.16L-4T21GD26			1,000		0,933	5,906	1,575	0,134	



Square shank

Dimensional drawing shows right-hand version. |  $f = f_1 + s/2$  |  $f_1 = f - s/2$  | Refer to the Walter online catalogue for more product information: [www.walter-tools.com](http://www.walter-tools.com) | Bodies and assembly parts are included in the scope of delivery

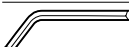
## Assembly parts

	s [inch]	0,118–0,157
	Clamping screw for grooving insert Tightening torque	FS2118 (T20IP) 3,688 lbs
	Allen key	FS1464 (T20IP)

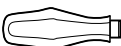
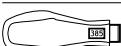
## Accessories

	s [inch]	0,118	0,157
	Torque screwdriver, analogue	FS2003	FS2004
	Torque screwdriver, digital	FS2248	FS2248
	Interchangeable blade	FS2015 (T20IP)	FS2015 (T20IP)

# Shank tool – Radial grooving

G5011...-P inch

## Groov-tec™ GD

- Screw clamping
- Precision cooling

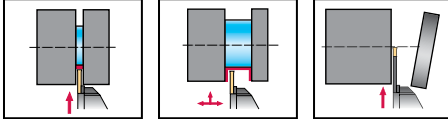

### Tool

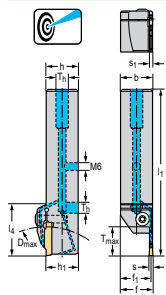

Designation	s inch	T <sub>max</sub> inch	D <sub>max</sub> inch	h = h <sub>1</sub> inch	b inch	f <sub>1</sub> inch	l <sub>1</sub> inch	l <sub>4</sub> inch	s <sub>1</sub> inch	T <sub>h</sub>	Type
★ G5011.12R-3T21GD26-P	0,118	0,827	4,724	0,750	0,750	0,703	5,118	1,575	0,094	G1/8"	GD26-3 ..
★ G5011.16R-3T21GD26-P		0,827	4,724	1,000	1,000	0,953	5,118	1,575	0,094	G1/8"	
★ G5011.12L-3T21GD26-P	0,118	0,827	4,724	0,750	0,750	0,703	5,118	1,575	0,094	G1/8"	GD26-3 ..
★ G5011.16L-3T21GD26-P		0,827	4,724	1,000	1,000	0,953	5,118	1,575	0,094	G1/8"	

Square shank

Dimensional drawing shows right-hand version. |  $f = f_1 + s/2$  |  $f_1 = f - s/2$  | The maximum recommended coolant pressure is 150 bar (2175 psi) | Refer to the Walter online catalogue for more product information: [www.walter-tools.com](http://www.walter-tools.com) | Bodies and assembly parts are included in the scope of delivery

### Assembly parts

	s [inch]	0,118
	Clamping screw for grooving insert Tightening torque	FS2118 (T20IP) 3,688 lbs
	G 1/8" threaded plug	FS2258 (SW 2)
	Allen key	FS1464 (T20IP)

### Accessories

	s [inch]	0,118
	Torque screwdriver, analogue	FS2004
	Torque screwdriver, digital	FS2248
	Interchangeable blade	FS2015 (T20IP)

## Shank tool – Radial grooving

G5011...-P inch

## Groov-tec™ GD

- Screw clamping
- Precision cooling



A2

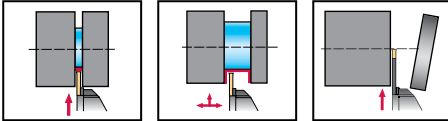

## Tool

		Designation	s inch	T <sub>max</sub> inch	h = h <sub>1</sub> inch	b inch	f <sub>1</sub> inch	l <sub>1</sub> inch	l <sub>2</sub> inch	s <sub>1</sub> inch	T <sub>h</sub>	Type
		★ G5011.16R-4T21GD26-P	0,157	0,827	1,000	1,000	0,933	5,118	1,575	0,134	G1/8"	GD26-4 ..

Square shank

$f = f_1 + s/2$  |  $f_1 = f - s/2$  | The maximum recommended coolant pressure is 150 bar (2175 psi) | Refer to the Walter online catalogue for more product information: [www.walter-tools.com](http://www.walter-tools.com) | Bodies and assembly parts are included in the scope of delivery

## Assembly parts

		s [inch]	0,157
	Clamping screw for grooving insert Tightening torque		FS2118 (T20IP) 3,688 lbs
	G 1/8" threaded plug		FS2258 (SW 2)
	Allen key		FS1464 (T20IP)

## Accessories

		s [inch]	0,157
	Torque screwdriver, analogue		FS2004
	Torque screwdriver, digital		FS2248
	Interchangeable blade		FS2015 (T20IP)

# Shank tool – Radial grooving

**G1011** mm
**Walter Cut**

– Screw clamping

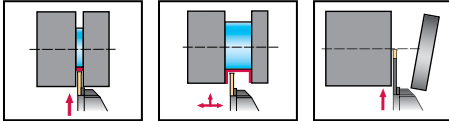
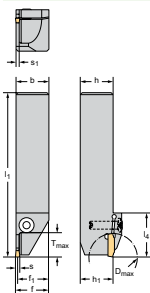
**Tool**

Square shank



Designation	s mm	T <sub>max</sub> mm	h = h <sub>1</sub> mm	b mm	f <sub>1</sub> mm	l <sub>1</sub> mm	l <sub>4</sub> mm	s <sub>1</sub> mm	Type
G1011.1616R-2T21GX24	2	21	16	16	15,3	150	40,3	1,6	GX24-1E2 ..
G1011.2020R-2T21GX24		21	20	20	19,2	150	40	1,6	
G1011.1616R-3T21GX24	3	21	16	16	14,8	150	40,3	2,4	GX24-2E3 .. GX24-2F3 ..
G1011.2012R-3T21GX24		21	20	12	10,8	150	40	2,4	
G1011.2020R-3T21GX24		21	20	20	18,8	150	40	2,4	
G1011.2525R-3T21GX24	4	21	25	25	23,8	150	40	2,4	GX24-3E4 .. GX24-3F4 ..
G1011.1616R-4T21GX24		21	16	16	14,3	150	40	3,4	
G1011.2020R-4T21GX24		21	20	20	18,3	150	40	3,4	
G1011.2525R-4T21GX24		21	25	25	23,3	150	40	3,4	
G1011.2525R-4T32GX24	5	32	25	25	23,3	165	55	3,4	GX24-3E5 .. GX24-3F5 ..
G1011.2020R-5T21GX24		21	20	20	17,9	150	40	4,2	
G1011.2525R-5T21GX24		21	25	25	22,9	150	40	4,2	
G1011.2525R-5T32GX24	6	32	25	25	22,9	165	55	4,2	GX24-4E6 ..
G1011.2020R-6T21GX24		21	20	20	17,4	150	40	5,2	
G1011.2525R-6T21GX24		21	25	25	22,4	150	40	5,2	
G1011.2525R-6T32GX24	2	32	25	25	22,4	165	55	5,2	GX24-1E2 ..
G1011.1616L-2T21GX24		21	16	16	15,3	150	40	1,6	
G1011.2020L-2T21GX24	3	21	20	20	19,3	150	40,3	1,6	GX24-2E3 .. GX24-2F3 ..
G1011.1616L-3T21GX24		21	16	16	14,8	150	40	2,4	
G1011.2012L-3T21GX24		21	20	12	10,8	150	40	2,4	
G1011.2020L-3T21GX24		21	20	20	18,8	150	40	2,4	
G1011.2525L-3T21GX24		21	25	25	23,8	150	40	2,4	
G1011.1616L-4T21GX24		4	21	16	16	14,3	150	40	
G1011.2020L-4T21GX24	21		20	20	18,3	150	40	3,4	
G1011.2525L-4T21GX24	21		25	25	23,3	150	40	3,4	
G1011.2525L-4T32GX24	32		25	25	23,3	165	55	3,4	
G1011.2020L-5T21GX24	5	21	20	20	17,9	150	40	4,2	GX24-3E5 .. GX24-3F5 ..
G1011.2525L-5T21GX24		21	25	25	22,9	150	40	4,2	
G1011.2525L-5T32GX24		32	25	25	22,9	165	55	4,2	
G1011.2020L-6T21GX24	6	21	20	20	17,4	150	40	5,2	GX24-4E6 ..
G1011.2525L-6T21GX24		21	25	25	22,4	150	40	5,2	
G1011.2525L-6T32GX24		32	25	25	22,4	165	55	5,2	

 Dimensional drawing shows right-hand version. | Refer to the Walter online catalogue for more product information: [www.walter-tools.com](http://www.walter-tools.com) | Bodies and assembly parts are included in the scope of delivery

**Assembly parts**

	s [mm]	2-6
	Clamping screw for grooving insert Tightening torque	FS2118 (T20IP) 5 Nm
	Allen key	FS1464 (T20IP)

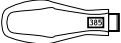
## Accessories

	s [mm]	2-6
	Torque screwdriver, analogue	FS2003
	Torque screwdriver, digital	FS2248
	Interchangeable blade	FS2015 (T20IP)

A2

# Shank tool – Radial grooving

**G1011** 
**Walter Cut**

– Screw clamping

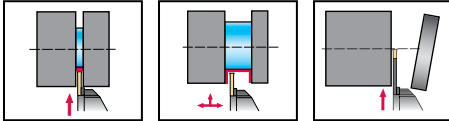
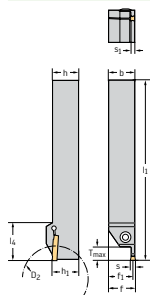
**Tool**

Square shank

Designation	s mm	T <sub>max</sub> mm	h = h <sub>1</sub> mm	b mm	f <sub>1</sub> mm	l <sub>1</sub> mm	l <sub>4</sub> mm	s <sub>1</sub> mm	Type
G1011.1616R-3T12GX24	3	12	16	16	14,8	135	35	2,4	GX24-2E3 .. GX24-2F3 ..
G1011.2020R-3T12GX24		12	20	20	18,8	145	35	2,4	
G1011.2525R-3T12GX24		12	25	25	23,8	145	35	2,4	
G1011.1616R-4T12GX24	4	12	16	16	14,3	135	35	3,4	GX24-3E4 .. GX24-3F4 ..
G1011.2020R-4T12GX24		12	20	20	18,3	145	35	3,4	
G1011.2525R-4T12GX24		12	25	25	23,3	145	35	3,4	
G1011.2020R-5T12GX24	5	12	20	20	17,9	145	35	4,2	GX24-3E5 .. GX24-3F5 ..
G1011.2525R-5T12GX24		12	25	25	22,9	145	35	4,2	
G1011.2020R-6T12GX24	6	12	20	20	17,4	145	35	5,2	GX24-4E6 ..
G1011.2525R-6T12GX24		12	25	25	22,4	145	35	5,2	
G1011.2525R-8T28GX30	8	28	25	25	22	165	55	6,1	GX30-5E8 ..
G1011.3232R-8T28GX30		28	32	32	29	165	55	6,1	
G1011.1616L-3T12GX24	3	12	16	16	14,8	135	35	2,4	GX24-2E3 .. GX24-2F3 ..
G1011.2020L-3T12GX24		12	20	20	18,8	145	35	2,4	
G1011.2525L-3T12GX24		12	25	25	23,8	145	35	2,4	
G1011.1616L-4T12GX24	4	12	16	16	14,3	135	35	3,4	GX24-3E4 .. GX24-3F4 ..
G1011.2020L-4T12GX24		12	20	20	18,3	145	35	3,4	
G1011.2525L-4T12GX24		12	25	25	23,3	145	35	3,4	
G1011.2020L-5T12GX24	5	12	20	20	17,9	145	35	4,2	GX24-3E5 .. GX24-3F5 ..
G1011.2525L-5T12GX24		12	25	25	22,9	145	35	4,2	
G1011.2020L-6T12GX24	6	12	20	20	17,4	145	35	5,2	GX24-4E6 ..
G1011.2525L-6T12GX24		12	25	25	22,4	145	35	5,2	
G1011.2525L-8T28GX30	8	28	25	25	22	165	55	6,1	GX30-5E8 ..
G1011.3232L-8T28GX30		28	32	32	29	165	55	6,1	

Dimensional drawing shows right-hand version. | For T<sub>max</sub> with diameters greater than D<sub>2</sub>, see „Technical information – Grooving“ |  $f = f_1 + s/2$  | Refer to the Walter online catalogue for more product information: [www.walter-tools.com](http://www.walter-tools.com) | Bodies and assembly parts are included in the scope of delivery

**Assembly parts**

	s [mm]	3–8
	Clamping screw for grooving insert Tightening torque	FS2118 (T20IP) 5 Nm
	Allen key	FS1464 (T20IP)

**Accessories**

	s [mm]	3–8
	Torque screwdriver, analogue	FS2003
	Torque screwdriver, digital	FS2248
	Interchangeable blade	FS2015 (T20IP)

## Shank tool – Radial grooving

G1011...-P 

## Walter Cut

- Screw clamping
- Precision cooling

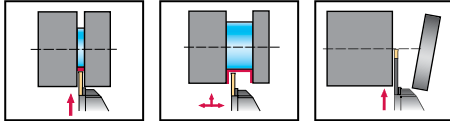

## Tool

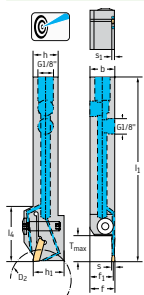

Designation	s mm	D <sub>max</sub> mm	T <sub>max</sub> mm	h = h <sub>1</sub> mm	b mm	f <sub>1</sub> mm	l <sub>1</sub> mm	l <sub>4</sub> mm	s <sub>1</sub> mm	Type
G1011.1616R-2T21GX24-P	2	80	21	16	16	15,3	120	40	1,6	GX24-1E2 ..
G1011.1616R-3T12GX24-P	3	50	12	16	16	14,8	120	31,5	2,4	GX24-2E3 .. GX24-2F3 ..
G1011.1616R-3T21GX24-P		80	21	16	16	14,8	120	40	2,4	
G1011.1616L-2T21GX24-P	2	80	21	16	16	15,3	120	40	1,6	GX24-1E2 ..
G1011.1616L-3T12GX24-P	3	50	12	16	16	14,8	120	31,5	2,4	GX24-2E3 .. GX24-2F3 ..
G1011.1616L-3T21GX24-P		80	21	16	16	14,8	120	40	2,4	

Square shank

Dimensional drawing shows right-hand version. | The maximum recommended coolant pressure is 150 bar (2175 psi) | Refer to the Walter online catalogue for more product information: [www.walter-tools.com](http://www.walter-tools.com) | Bodies and assembly parts are included in the scope of delivery

## Assembly parts

	s [mm]	2-3
	Clamping screw for grooving insert Tightening torque	FS2118 (T20IP) 5 Nm
	G 1/8" threaded plug	FS2258 (SW 2)
	Allen key	FS1464 (T20IP)

## Accessories

	s [mm]	2-3
	Torque screwdriver, analogue	FS2003
	Torque screwdriver, digital	FS2248
	Interchangeable blade	FS2015 (T20IP)

# Shank tool – Radial grooving

**G1011...-P** mm

## Walter Cut

- Screw clamping
- Precision cooling

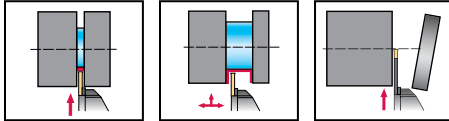

### Tool

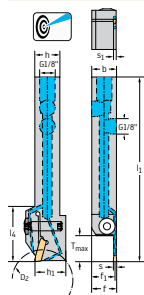

Designation	s mm	T <sub>max</sub> mm	h = h <sub>1</sub> mm	b mm	f <sub>1</sub> mm	l <sub>1</sub> mm	l <sub>4</sub> mm	s <sub>1</sub> mm	Type
G1011.1616R-4T12GX24-P	4	12	16	16	14,3	120	35	3,4	GX24-3E4 .. GX24-3F4 ..
G1011.1616L-4T12GX24-P	4	12	16	16	14,3	120	35	3,4	GX24-3E4 .. GX24-3F4 ..

Square shank

Dimensional drawing shows right-hand version. |  $f = f_1 + s/2$  | For the connection set for internal coolant supply with G1/8" thread, see „Assembly parts and accessories“ | The maximum recommended coolant pressure is 150 bar (2175 psi) | Refer to the Walter online catalogue for more product information: [www.walter-tools.com](http://www.walter-tools.com) | Bodies and assembly parts are included in the scope of delivery

### Assembly parts

	s [mm]	4
	Clamping screw for grooving insert Tightening torque	FS2118 (T20IP) 5 Nm
	G 1/8" threaded plug	FS2258 (SW 2)
	Allen key	FS1464 (T20IP)

### Accessories

	s [mm]	4
	Torque screwdriver, analogue	FS2003
	Torque screwdriver, digital	FS2248
	Interchangeable blade	FS2015 (T20IP)



## Shank tool – Radial grooving

G1011...-P 

## Walter Cut

- Screw clamping
- Precision cooling

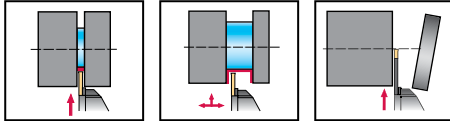

## Tool

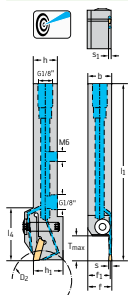

Square shank

Designation	s mm	D <sub>max</sub> mm	T <sub>max</sub> mm	h = h <sub>1</sub> mm	b mm	f <sub>1</sub> mm	l <sub>1</sub> mm	l <sub>4</sub> mm	s <sub>1</sub> mm	Type
G1011.2020R-2T21GX24-P	2	80	21	20	20	19,2	125	40	1,6	GX24-1E2 ..
G1011.2525R-2T21GX24-P		80	21	25	25	24,2	130	40	1,5	
G1011.2020R-3T12GX24-P	3	50	12	20	20	18,8	120	31,5	2,4	GX24-2E3 .. GX24-2F3 ..
G1011.2020R-3T21GX24-P		80	21	20	20	18,8	125	40	2,4	
G1011.2020R-3T33GX34-P		140	33	20	20	18,8	140	53	2,4	GX34-2E3 ..
G1011.2525R-3T21GX24-P		80	21	25	25	23,8	130	40	2,4	
G1011.2525R-3T33GX34-P	4	140	33	25	25	23,8	145	53	2,4	GX34-2E3 ..
G1011.2020R-4T33GX34-P		140	33	20	20	18,4	140	53	3,3	
G1011.2525R-4T33GX34-P	4	140	33	25	25	23,4	145	53	3,3	GX34-3E4 ..
G1011.2020L-2T21GX24-P		2	80	21	20	20	19,2	125	40	
G1011.2525L-2T21GX24-P	80		21	25	25	24,2	130	40	1,5	
G1011.2020L-3T12GX24-P	3	50	12	20	20	18,8	120	31,5	2,4	GX24-2E3 .. GX24-2F3 ..
G1011.2020L-3T21GX24-P		80	21	20	20	18,8	125	40	2,4	
G1011.2020L-3T33GX34-P		140	33	20	20	18,8	140	53	2,4	GX34-2E3 ..
G1011.2525L-3T21GX24-P		80	21	25	25	23,8	130	40	2,4	
G1011.2525L-3T33GX34-P	4	140	33	25	25	23,8	145	53	2,4	GX34-2E3 ..
G1011.2020L-4T33GX34-P		140	33	20	20	18,4	140	53	3,3	
G1011.2525L-4T33GX34-P	4	140	33	25	25	23,4	145	53	3,3	GX34-3E4 ..

Dimensional drawing shows right-hand version. | The maximum recommended coolant pressure is 150 bar (2175 psi) | Refer to the Walter online catalogue for more product information: [www.walter-tools.com](http://www.walter-tools.com) | Bodies and assembly parts are included in the scope of delivery

## Assembly parts

	s [mm]	2	3	4
	Clamping screw for grooving insert Tightening torque	FS2118 (T20IP) 5 Nm	FS2118 (T20IP) 5 Nm	M06X025 ISO4762 12.9 (SW 5)
	G 1/8" threaded plug	FS2258 (SW 2)	FS2258 (SW 2)	FS2258 (SW 2)
	M6 threaded plug	FS2288 (SW 3)	FS2288 (SW 3)	FS2288 (SW 3)
	Allen key	FS1464 (T20IP)	FS1464 (T20IP)	ISO2936-5 (SW 5)

## Accessories

	s [mm] D <sub>max</sub> [mm]	2-3 50-80	3-4 140
	Torque screwdriver, analogue	FS2003	
	Torque screwdriver, digital	FS2248	
	Torque T-handle		FS2041
	Interchangeable blade	FS2015 (T20IP)	FS2052 (SW 5)

## Shank tool – Radial grooving

 G1011...-P mm
**Walter Cut**

- Screw clamping
- Precision cooling

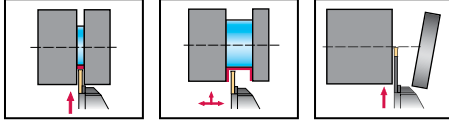
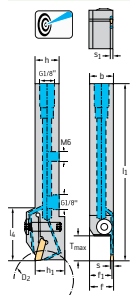
**Tool**

Square shank



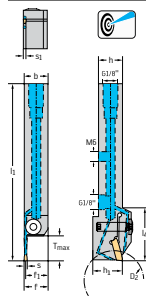

Designation	s mm	T <sub>max</sub> mm	h = h <sub>1</sub> mm	b mm	f <sub>1</sub> mm	l <sub>1</sub> mm	l <sub>4</sub> mm	s <sub>1</sub> mm	Type
G1011.2525R-3T12GX24-P	3	12	25	25	23,8	125	35	2,4	GX24-2E3 .. GX24-2F3 ..
G1011.2020R-4T12GX24-P	4	12	20	20	18,3	120	35	3,4	GX24-3E4 .. GX24-3F4 ..
G1011.2020R-4T21GX24-P		21	20	20	18,3	125	40	3,4	
G1011.2525R-4T12GX24-P		12	25	25	23,3	125	35	3,4	
G1011.2525R-4T21GX24-P		21	25	25	23,3	130	40	3,4	
G1011.2525R-4T32GX24-P		32	25	25	23,3	145	55	3,4	
G1011.2020R-5T12GX24-P	5	12	20	20	17,9	120	35	4,2	GX24-3E5 .. GX24-3F5 ..
G1011.2020R-5T21GX24-P		21	20	20	17,9	125	40	4,2	
G1011.2525R-5T12GX24-P		12	25	25	22,9	125	35	4,2	
G1011.2525R-5T21GX24-P		21	25	25	22,9	130	40	4,2	
G1011.2525R-5T32GX24-P		32	25	25	22,9	145	55	4,2	
G1011.2525R-6T12GX24-P	6	12	25	25	22,4	125	35	5,2	GX24-4E6 ..
G1011.2525R-6T21GX24-P		21	25	25	22,4	130	40	5,2	
G1011.2525R-6T32GX24-P		32	25	25	22,4	145	55	5,2	
G1011.2525R-8T28GX30-P	8	28	25	25	22	145	55	6,1	GX30-5E8 ..
G1011.3225R-8T28GX30-P		28	32	25	22	145	55	6,1	
G1011.2525L-3T12GX24-P	3	12	25	25	23,8	125	35	2,4	GX24-2E3 .. GX24-2F3 ..
G1011.2020L-4T12GX24-P	4	12	20	20	18,3	120	35	3,4	GX24-3E4 .. GX24-3F4 ..
G1011.2020L-4T21GX24-P		21	20	20	18,3	125	40	3,4	
G1011.2525L-4T12GX24-P		12	25	25	23,3	125	35	3,4	
G1011.2525L-4T21GX24-P		21	25	25	23,3	130	40	3,4	
G1011.2525L-4T32GX24-P		32	25	25	23,3	145	55	3,4	
G1011.2020L-5T12GX24-P	5	12	20	20	17,9	120	35	4,2	GX24-3E5 .. GX24-3F5 ..
G1011.2020L-5T21GX24-P		21	20	20	17,9	125	40	4,2	
G1011.2525L-5T12GX24-P		12	25	25	22,9	125	35	4,2	
G1011.2525L-5T21GX24-P		21	25	25	22,9	130	40	4,2	
G1011.2525L-5T32GX24-P		32	25	25	22,9	145	55	4,2	
G1011.2525L-6T12GX24-P	6	12	25	25	22,4	125	35	5,2	GX24-4E6 ..
G1011.2525L-6T21GX24-P		21	25	25	22,4	130	40	5,2	
G1011.2525L-6T32GX24-P		32	25	25	22,4	145	55	5,2	
G1011.2525L-8T28GX30-P	8	28	25	25	22	145	55	6,1	GX30-5E8 ..
G1011.3225L-8T28GX30-P	8	28	32	25	22	145	55	6,1	GX30-5E8 ..





Square shank

Dimensional drawing shows right-hand version. |  $f = f_1 + s/2$  | For the connection set for internal coolant supply with G1/8" thread, see „Assembly parts and accessories“ | The maximum recommended coolant pressure is 150 bar (2175 psi) | Refer to the Walter online catalogue for more product information: [www.walter-tools.com](http://www.walter-tools.com) | Bodies and assembly parts are included in the scope of delivery

## Assembly parts

	s [mm]	3-8
	Clamping screw for grooving insert Tightening torque	FS2118 (T20IP) 5 Nm
	G 1/8" threaded plug	FS2258 (SW 2)
	M6 threaded plug	FS2288 (SW 3)
	Allen key	FS1464 (T20IP)

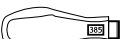
## Accessories

	s [mm]	3-8
	Torque screwdriver, analogue	FS2003
	Torque screwdriver, digital	FS2248
	Interchangeable blade	FS2015 (T20IP)

# Shank tool – Radial grooving

**G1011** inch
**Walter Cut**

– Screw clamping

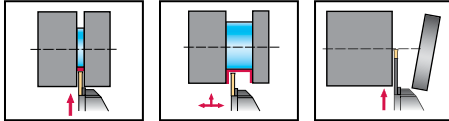
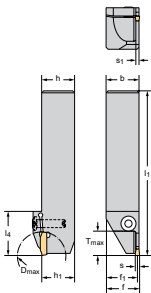
**Tool**

Square shank



Designation	s inch	D <sub>max</sub> inch	T <sub>max</sub> inch	h = h <sub>1</sub> inch	b inch	f <sub>1</sub> inch	l <sub>1</sub> inch	l <sub>4</sub> inch	s <sub>1</sub> inch	Type
G1011.12R-2T21GX24	0,079	3,150	0,827	0,750	0,750	0,72	5,906	1,575	0,063	GX24-1E2 ..
G1011.16R-2T21GX24		3,150	0,827	1,000	1,000	0,97	5,906	1,575	0,063	
G1011.10R-3T21GX24	0,118	3,150	0,827	0,625	0,625	0,578	5,906	1,575	0,094	GX24-2E3 .. GX24-2F3 ..
G1011.12R-3T21GX24		3,150	0,827	0,750	0,750	0,701	5,906	1,575	0,094	
G1011.16R-3T21GX24		3,150	0,827	1,000	1,000	0,953	5,906	1,575	0,094	
G1011.20R-3T21GX24	0,157	3,937	0,827	1,250	1,250	1,205	5,906	1,575	0,094	GX24-3E4 .. GX24-3F4 ..
G1011.12R-4T21GX24		3,150	0,827	0,750	0,750	0,685	5,906	1,575	0,134	
G1011.16R-4T21GX24		3,150	0,827	1,000	1,000	0,933	5,906	1,575	0,134	
G1011.20R-4T26GX24		3,937	1,024	1,250	1,250	1,181	6,142	1,811	0,134	
G1011.16R-5T21GX24	0,197	3,150	0,827	1,000	1,000	0,917	5,906	1,575	0,165	GX24-3E5 .. GX24-3F5 ..
G1011.16R-5T32GX24		4,724	1,260	1,000	1,000	0,917	6,496	2,165	0,165	
G1011.20R-5T26GX24		3,937	1,024	1,250	1,250	1,167	6,142	1,811	0,165	
G1011.12R-6T21GX24	0,236	3,150	0,827	0,750	0,750	0,646	5,906	1,575	0,205	GX24-4E6 ..
G1011.16R-6T21GX24		3,150	0,827	1,000	1,000	0,898	5,906	1,575	0,205	
G1011.16R-6T32GX24		4,724	1,260	1,000	1,000	0,898	6,496	2,165	0,205	
G1011.20R-6T21GX24		3,937	0,827	1,250	1,250	1,148	5,906	1,575	0,205	
G1011.20R-6T32GX24		5,512	1,260	1,250	1,250	1,148	6,496	2,165	0,205	
G1011.12L-2T21GX24	0,079	3,150	0,827	0,750	0,750	0,72	5,906	1,575	0,063	GX24-1E2 ..
G1011.16L-2T21GX24		3,150	0,827	1,000	1,000	0,97	5,906	1,575	0,063	
G1011.10L-3T21GX24	0,118	3,150	0,827	0,625	0,625	0,578	5,906	1,575	0,094	GX24-2E3 .. GX24-2F3 ..
G1011.12L-3T21GX24		3,150	0,827	0,750	0,750	0,701	5,906	1,575	0,094	
G1011.16L-3T21GX24		3,150	0,827	1,000	1,000	0,953	5,906	1,575	0,094	
G1011.20L-3T21GX24	0,157	3,937	0,827	1,250	1,250	1,205	5,906	1,575	0,094	GX24-3E4 .. GX24-3F4 ..
G1011.12L-4T21GX24		3,150	0,827	0,750	0,750	0,685	5,906	1,575	0,134	
G1011.16L-4T21GX24		3,150	0,827	1,000	1,000	0,933	5,906	1,575	0,134	
G1011.20L-4T26GX24		3,937	1,024	1,250	1,250	1,181	6,142	1,811	0,134	
G1011.16L-5T21GX24	0,197	3,150	0,827	1,000	1,000	0,917	5,906	1,575	0,165	GX24-3E5 .. GX24-3F5 ..
G1011.16L-5T32GX24		4,724	1,260	1,000	1,000	0,917	6,496	2,165	0,165	
G1011.20L-5T26GX24		3,937	1,024	1,250	1,250	1,167	6,142	1,811	0,165	
G1011.12L-6T21GX24	0,236	3,150	0,827	0,750	0,750	0,646	5,906	1,575	0,205	GX24-4E6 ..
G1011.16L-6T21GX24		3,150	0,827	1,000	1,000	0,898	5,906	1,575	0,205	
G1011.16L-6T32GX24		4,724	1,260	1,000	1,000	0,898	6,496	2,165	0,205	
G1011.20L-6T21GX24		3,937	0,827	1,250	1,250	1,148	5,906	1,575	0,205	
G1011.20L-6T32GX24		5,512	1,260	1,250	1,250	1,148	6,496	2,165	0,205	

 Dimensional drawing shows right-hand version. | Refer to the Walter online catalogue for more product information: [www.walter-tools.com](http://www.walter-tools.com) | Bodies and assembly parts are included in the scope of delivery

**Assembly parts**

	s [inch]	0,079–0,236
	Clamping screw for grooving insert Tightening torque	FS2118 (T20IP) 3,688 lbs
	Allen key	FS1464 (T20IP)

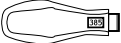
## Accessories

	s [inch]	0,079–0,236
	Torque screwdriver, analogue	FS2004
	Torque screwdriver, digital	FS2248
	Interchangeable blade	FS2015 (T20IP)

A2

# Shank tool – Radial grooving

**G1011** inch
**Walter Cut**

– Screw clamping

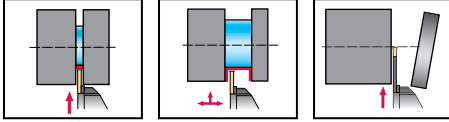
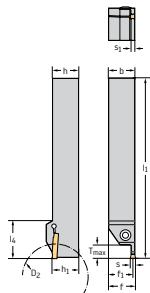
**Tool**

Square shank

Designation	s inch	T <sub>max</sub> inch	h = h <sub>1</sub> inch	b inch	f <sub>1</sub> inch	h <sub>1</sub> inch	l <sub>4</sub> inch	s <sub>1</sub> inch	Type
G1011.10R-3T12GX24	0,118	0,472	0,625	0,625	0,578	5,315	1,378	0,094	GX24-2E3 .. GX24-2F3 ..
G1011.12R-3T12GX24		0,472	0,750	0,750	0,701	5,709	1,378	0,094	
G1011.16R-3T12GX24		0,472	1,000	1,000	0,953	5,709	1,378	0,094	
G1011.12R-4T12GX24	0,157	0,472	0,750	0,750	0,685	5,709	1,378	0,134	GX24-3E4 .. GX24-3F4 ..
G1011.16R-4T12GX24		0,472	1,000	1,000	0,933	5,709	1,378	0,134	
G1011.16R-4T32GX24		1,260	1,000	1,000	0,933	6,496	2,165	0,134	
G1011.12R-5T12GX24	0,197	0,472	0,750	0,750	0,669	5,709	1,378	0,165	GX24-3E5 .. GX24-3F5 ..
G1011.12R-6T12GX24	0,236	0,472	0,750	0,750	0,646	5,709	1,378	0,205	GX24-4E6 ..
G1011.16R-6T12GX24		0,472	1,000	1,000	0,898	5,709	1,378	0,205	
G1011.16R-8T28GX30	0,315	1,102	1,000	1,000	0,882	6,496	2,165	0,24	GX30-5E8 ..
G1011.20R-8T38GX30		1,496	1,250	1,250	1,130	6,890	2,559	0,24	
G1011.24R-8T38GX30		1,496	1,500	1,500	1,378	6,890	2,559	0,24	
G1011.10L-3T12GX24	0,118	0,472	0,625	0,625	0,578	5,315	1,378	0,094	GX24-2E3 .. GX24-2F3 ..
G1011.12L-3T12GX24		0,472	0,750	0,750	0,701	5,709	1,378	0,094	
G1011.16L-3T12GX24		0,472	1,000	1,000	0,953	5,709	1,378	0,094	
G1011.12L-4T12GX24	0,157	0,472	0,750	0,750	0,685	5,709	1,378	0,134	GX24-3E4 .. GX24-3F4 ..
G1011.16L-4T12GX24		0,472	1,000	1,000	0,933	5,709	1,378	0,134	
G1011.16L-4T32GX24		1,260	1,000	1,000	0,933	6,496	2,165	0,134	
G1011.12L-6T12GX24	0,236	0,472	0,750	0,750	0,646	5,709	1,378	0,205	GX24-4E6 ..
G1011.16L-6T12GX24		0,472	1,000	1,000	0,898	5,709	1,378	0,205	
G1011.16L-8T28GX30	0,315	1,102	1,000	1,000	0,882	6,496	2,165	0,24	GX30-5E8 ..
G1011.20L-8T38GX30		1,496	1,250	1,250	1,130	6,890	2,559	0,24	
G1011.24L-8T38GX30		1,496	1,500	1,500	1,378	6,890	2,559	0,24	

 Dimensional drawing shows right-hand version. | For T<sub>max</sub> with diameters greater than D<sub>2</sub>, see „Technical information – Grooving“ |  $f = f_1 + s/2$  | Refer to the Walter online catalogue for more product information: [www.walter-tools.com](http://www.walter-tools.com) | Bodies and assembly parts are included in the scope of delivery

**Assembly parts**

	s [inch]	0,118–0,315
	Clamping screw for grooving insert Tightening torque	FS2118 (T20IP) 3,688 lbs
	Allen key	FS1464 (T20IP)

**Accessories**

	s [inch]	0,118–0,315
	Torque screwdriver, analogue	FS2004
	Torque screwdriver, digital	FS2248
	Interchangeable blade	FS2015 (T20IP)

## Shank tool – Radial grooving

G1011...-P inch

## Walter Cut

- Screw clamping
- Precision cooling

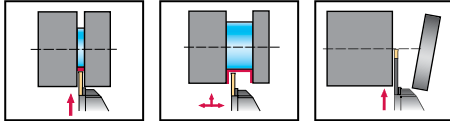

## Tool

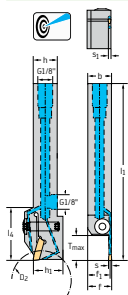

Square shank

Designation	s inch	D <sub>max</sub> inch	T <sub>max</sub> inch	h = h <sub>1</sub> inch	b inch	f <sub>1</sub> inch	l <sub>1</sub> inch	l <sub>4</sub> inch	s <sub>1</sub> inch	Type
G1011.12R-3T21GX24-P	0,118	3,150	0,827	0,750	0,750	0,701	5,906	1,575	0,094	GX24-2E3 .. GX24-2F3 ..
G1011.12R-3T33GX34-P		5,512	1,299	0,750	0,750	0,703	5,906	2,087	0,094	GX34-2E3 ..
G1011.16R-3T12GX24-P		1,969	0,472	1,000	1,000	0,953	5,906	1,575	0,094	GX24-2E3 .. GX24-2F3 ..
G1011.16R-3T21GX24-P		3,150	0,827	1,000	1,000	0,953	5,906	1,575	0,094	GX24-2E3 .. GX24-2F3 ..
G1011.16R-3T33GX34-P	5,512	1,299	1,000	1,000	0,953	5,906	2,087	0,094	GX34-2E3 ..	
G1011.16R-4T33GX34-P	0,157	5,512	1,299	1,000	1,000	0,937	5,906	2,087	0,130	GX34-3E4 ..
G1011.12L-3T21GX24-P	0,118	3,150	0,827	0,750	0,750	0,701	5,906	1,575	0,094	GX24-2E3 .. GX24-2F3 ..
G1011.12L-3T33GX34-P		5,512	1,299	0,750	0,750	0,703	5,906	2,087	0,094	GX34-2E3 ..
G1011.16L-3T12GX24-P		1,969	0,472	1,000	1,000	0,953	5,906	1,575	0,094	GX24-2E3 .. GX24-2F3 ..
G1011.16L-3T21GX24-P		3,150	0,827	1,000	1,000	0,953	5,906	1,575	0,094	GX24-2E3 .. GX24-2F3 ..
G1011.16L-3T33GX34-P	5,512	1,299	1,000	1,000	0,953	5,906	2,087	0,094	GX34-2E3 ..	
G1011.16L-4T33GX34-P	0,157	5,512	1,299	1,000	1,000	0,937	5,906	2,087	0,130	GX34-3E4 ..

Dimensional drawing shows right-hand version. | The maximum recommended coolant pressure is 150 bar (2175 psi) | Refer to the Walter online catalogue for more product information: [www.walter-tools.com](http://www.walter-tools.com) | Bodies and assembly parts are included in the scope of delivery

## Assembly parts

	s [inch]	0,118	0,157
	Clamping screw for grooving insert Tightening torque	FS2118 (T20IP) 3,688 lbs	M06X025 ISO4762 12.9 (SW 5)
	G 1/8" threaded plug	FS2258 (SW 2)	FS2258 (SW 2)
	M6 threaded plug	FS2288 (SW 3)	FS2288 (SW 3)
	Allen key	FS1464 (T20IP)	ISO2936-5 (SW 5)

## Accessories

	s [inch] D <sub>max</sub> [inch]	0,118 1,969–3,15	0,118–0,157 5,512
	Torque screwdriver, analogue	FS2004	
	Torque screwdriver, digital	FS2248	
	Torque T-handle		FS2042
	Interchangeable blade	FS2015 (T20IP)	FS2052 (SW 5)

# Shank tool – Radial grooving

**G1011...-P** inch

## Walter Cut

- Screw clamping
- Precision cooling

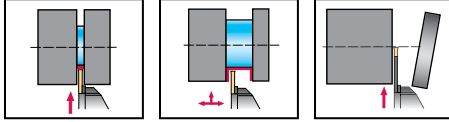

### Tool

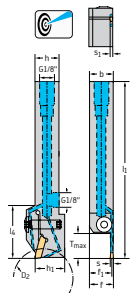

Square shank

Designation	s inch	T <sub>max</sub> inch	h = h <sub>1</sub> inch	b inch	f <sub>1</sub> inch	h <sub>1</sub> inch	l <sub>4</sub> inch	s <sub>1</sub> inch	Type
G1011.12R-4T21GX24-P	0,157	0,827	0,750	0,750	0,685	5,906	1,575	0,134	GX24-3E4 .. GX24-3F4 ..
G1011.16R-4T12GX24-P			1,000	1,000	0,933	5,709	1,378	0,134	
G1011.16R-4T21GX24-P			1,000	1,000	0,933	5,906	1,575	0,134	GX24-3E5 .. GX24-3F5 ..
G1011.16R-4T32GX24-P			1,000	1,000	0,933	5,906	2,165	0,134	
G1011.12R-5T21GX24-P	0,197	0,827	0,750	0,750	0,669	5,906	1,575	0,165	GX24-3E5 .. GX24-3F5 ..
G1011.16R-5T12GX24-P			1,000	1,000	0,917	5,709	1,378	0,165	
G1011.16R-5T21GX24-P			1,000	1,000	0,917	5,906	1,575	0,165	GX24-4E6 ..
G1011.16R-5T32GX24-P			1,000	1,000	0,917	5,906	2,165	0,165	
G1011.16R-6T12GX24-P	0,236	0,472	1,000	1,000	0,898	5,709	1,378	0,205	GX24-4E6 ..
G1011.16R-6T21GX24-P			1,000	1,000	0,898	5,906	1,575	0,205	
G1011.16R-6T32GX24-P			1,000	1,000	0,898	5,906	2,165	0,205	
G1011.12L-4T21GX24-P	0,157	0,827	0,750	0,750	0,685	5,906	1,575	0,134	GX24-3E4 .. GX24-3F4 ..
G1011.16L-4T21GX24-P			1,000	1,000	0,933	5,906	1,575	0,134	
G1011.16L-4T32GX24-P			1,000	1,000	0,933	5,906	2,165	0,134	
G1011.12L-5T21GX24-P	0,197	0,827	0,750	0,750	0,669	5,906	1,575	0,165	GX24-3E5 .. GX24-3F5 ..
G1011.16L-5T12GX24-P			1,000	1,000	0,917	5,709	1,378	0,165	
G1011.16L-5T21GX24-P			1,000	1,000	0,917	5,906	1,575	0,165	GX24-4E6 ..
G1011.16L-5T32GX24-P			1,000	1,000	0,917	5,906	2,165	0,165	
G1011.16L-6T21GX24-P	0,236	0,827	1,000	1,000	0,898	5,906	1,575	0,205	GX24-4E6 ..
G1011.16L-6T32GX24-P			1,000	1,000	0,898	5,906	2,165	0,205	

Dimensional drawing shows right-hand version. |  $f = f_1 + s/2$  | For the connection set for internal coolant supply with G1/8" thread, see „Assembly parts and accessories“ | The maximum recommended coolant pressure is 150 bar (2175 psi) | Refer to the Walter online catalogue for more product information: [www.walter-tools.com](http://www.walter-tools.com) | Bodies and assembly parts are included in the scope of delivery

### Assembly parts

	s [inch]	0,157–0,236
	Clamping screw for grooving insert Tightening torque	FS2118 (T20IP) 3,688 lbs
	G 1/8" threaded plug	FS2258 (SW 2)
	Allen key	FS1464 (T20IP)

### Accessories

	s [inch]	0,157–0,236
	Torque screwdriver, analogue	FS2004
	Torque screwdriver, digital	FS2248
	Interchangeable blade	FS2015 (T20IP)



## Shank tool – Universal

G1511 

## Walter Cut



A2

– Screw clamping

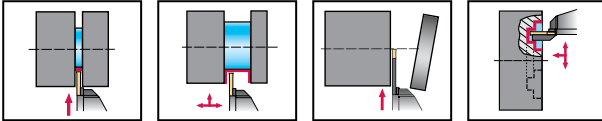

Tool		s mm	T <sub>max</sub> mm	h = h <sub>1</sub> mm	b mm	f <sub>1</sub> mm	l <sub>1</sub> mm	l <sub>4</sub> mm	Type
	Designation								
	G1511.2020R-T6GX24	2 - 6	6	20	20	17,9	143,5	33,5	GX24- ..
	G1511.2525R-T6GX24		6	25	25	22,9	143,5	33,5	
	G1511.2020L-T6GX24	2 - 6	6	20	20	17,9	143,5	33,5	GX24- ..
	G1511.2525L-T6GX24		6	25	25	22,9	143,5	33,5	

Square shank

Dimensional drawing shows right-hand version. | For information on the smallest possible axial groove [D<sub>min</sub>], see „Technical information“ |  $f = f_1 + s/2$  | Refer to the Walter online catalogue for more product information: [www.walter-tools.com](http://www.walter-tools.com) | Bodies and assembly parts are included in the scope of delivery

Assembly parts		s [mm]	2 - 6
	Clamping screw for grooving insert Tightening torque		FS2118 (T20IP) 5 Nm
	Allen key		FS1464 (T20IP)
Accessories		s [mm]	2 - 6
	Torque screwdriver, analogue		FS2003
	Torque screwdriver, digital		FS2248
	Interchangeable blade		FS2015 (T20IP)

## Shank tool – Universal

 G1511 inch

## Walter Cut



– Screw clamping

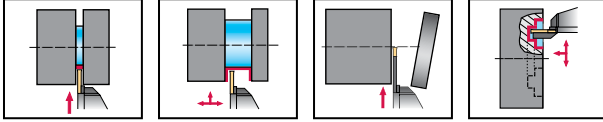

## Tool

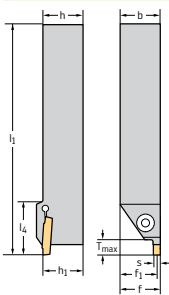

Designation	s inch	T <sub>max</sub> inch	h = h <sub>1</sub> inch	b inch	f <sub>1</sub> inch	l <sub>1</sub> inch	l <sub>4</sub> inch	Type
G1511.12R-T6GX24	0,079 - 0,236	0,236	0,750	0,750	0,665	5,61	1,319	GX24- ..
G1511.16R-T6GX24		0,236	1,000	1,000	0,911	5,665	1,319	
G1511.12L-T6GX24	0,079 - 0,236	0,236	0,750	0,750	0,665	5,61	1,319	GX24- ..
G1511.16L-T6GX24		0,236	1,000	1,000	0,911	5,665	1,319	

Square shank

 Dimensional drawing shows right-hand version. | For information on the smallest possible axial groove [D<sub>min</sub>], see „Technical information“ |  $f = f_1 + s/2$  | Refer to the Walter online catalogue for more product information: [www.walter-tools.com](http://www.walter-tools.com) | Bodies and assembly parts are included in the scope of delivery

## Assembly parts

	s [inch]	0.079 - 0.236
	Clamping screw for grooving insert Tightening torque	FS2118 (T20IP) 3,688 lbs
	Allen key	FS1464 (T20IP)

## Accessories

	s [inch]	0.079 - 0.236
	Torque screwdriver, analogue	FS2004
	Torque screwdriver, digital	FS2248
	Interchangeable blade	FS2015 (T20IP)

## Shank tool – 90° universal

G1521 

## Walter Cut



A2

– Screw clamping

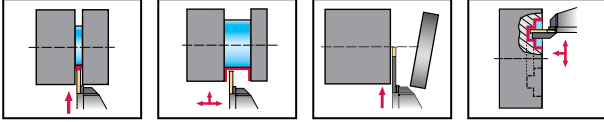

Tool		s mm	T <sub>max</sub> mm	h = h <sub>1</sub> mm	b mm	l <sub>1</sub> mm	l <sub>4</sub> mm	f <sub>1</sub> mm	l <sub>21</sub> mm	Type
	Designation									
	G1521.2020R-T6GX24	2 - 6	6	20	20	137,85	27	26,5	134,9	GX24- ..
	G1521.2525R-T6GX24		6	25	25	137,85	27	31,5	134,9	
	G1521.2020L-T6GX24	2 - 6	6	20	20	137,85	27	26,5	134,9	GX24- ..
	G1521.2525L-T6GX24		6	25	25	137,85	27	31,5	134,9	

Square shank

Dimensional drawing shows right-hand version. |  $l_1 = l_{21} + s/2$  | For information on the smallest possible axial groove [D<sub>min</sub>], see „Technical information“ | Refer to the Walter online catalogue for more product information: [www.walter-tools.com](http://www.walter-tools.com) | Bodies and assembly parts are included in the scope of delivery

Assembly parts		s [mm]	2 - 6
	Clamping screw for grooving insert Tightening torque		FS2118 (T20IP) 5 Nm
	Allen key		FS1464 (T20IP)

Accessories		s [mm]	2 - 6
	Torque screwdriver, analogue		FS2003
	Torque screwdriver, digital		FS2248
	Interchangeable blade		FS2015 (T20IP)

# Shank tool – 90° universal

G1521 inch

## Walter Cut



– Screw clamping

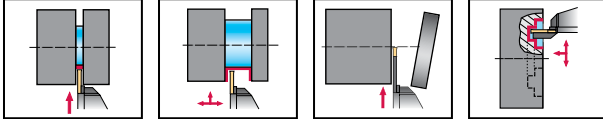

### Tool

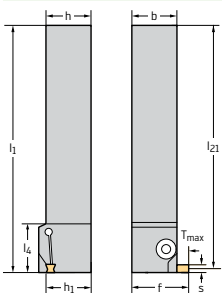

Designation	s inch	T <sub>max</sub> inch	h = h <sub>1</sub> inch	b inch	l <sub>1</sub> inch	l <sub>4</sub> inch	f <sub>1</sub> inch	l <sub>21</sub> inch	Type
G1521.12R-T6GX24	0,079 - 0,236	0,236	0,750	0,750	5,388	0,939	1,006	5,270	GX24- ..
G1521.16R-T6GX24		0,236	1,000	1,000	5,443	0,994	1,256	5,325	
G1521.16L-T6GX24	0,079 - 0,236	0,236	1,000	1,000	5,443	0,994	1,256	5,325	GX24- ..

Square shank

Dimensional drawing shows right-hand version. |  $l_1 = l_{21} + s/2$  | For information on the smallest possible axial groove [D<sub>min</sub>], see „Technical information“ | Refer to the Walter online catalogue for more product information: [www.walter-tools.com](http://www.walter-tools.com) | Bodies and assembly parts are included in the scope of delivery

### Assembly parts

	s [inch]	0.079 - 0.236
	Clamping screw for grooving insert Tightening torque	FS2118 (T20IP) 3,688 lbs
	Allen key	FS1464 (T20IP)

### Accessories

	s [inch]	0.079 - 0.236
	Torque screwdriver, analogue	FS2004
	Torque screwdriver, digital	FS2248
	Interchangeable blade	FS2015 (T20IP)

## Shank tool – 45° universal

G1551 

Walter Cut



A2

– Screw clamping

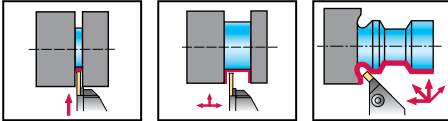

## Tool

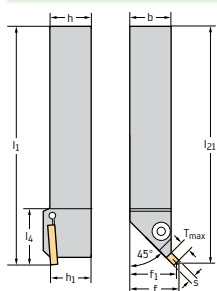

Designation

s  
mm $T_{max}$   
mmh = h<sub>1</sub>  
mmb  
mmf<sub>1</sub>  
mml<sub>1</sub>  
mml<sub>4</sub>  
mml<sub>21</sub>  
mm

Type

G1551.2020R-T6GX24

2 - 6

6

20

20

23,2

146,75

33,1

143,1

GX24- ..

G1551.2525R-T6GX24

6

25

25

28,2

146,75

33,1

143,1

G1551.2020L-T6GX24

2 - 6

6

20

20

23,2

146,75

33,1

143,1

GX24- ..

G1551.2525L-T6GX24

6

25

25

28,2

146,75

33,1

143,1

Square shank

Dimensional drawing shows right-hand version.  $l = f_1 + 0.707 \times s/2$  |  $l_1 = l_{21} + 0.707 \times s/2$  | Refer to the Walter online catalogue for more product information: [www.walter-tools.com](http://www.walter-tools.com) | Bodies and assembly parts are included in the scope of delivery

## Assembly parts

	s [mm]	2 - 6
	Clamping screw for grooving insert Tightening torque	FS2118 (T20IP) 5 Nm
	Allen key	FS1464 (T20IP)

## Accessories

	s [mm]	2 - 6
	Torque screwdriver, analogue	FS2003
	Torque screwdriver, digital	FS2248
	Interchangeable blade	FS2015 (T20IP)

# Shank tool – 45° universal

**G1551** inch
**Walter Cut**

– Screw clamping

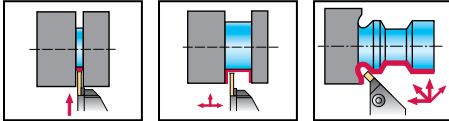

## Tool

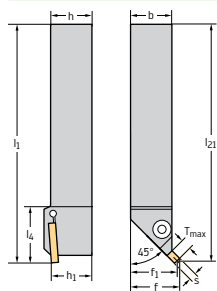

Designation	s inch	T <sub>max</sub> inch	h = h <sub>1</sub> inch	b inch	f <sub>1</sub> inch	l <sub>1</sub> inch	l <sub>4</sub> inch	l <sub>21</sub> inch	Type
G1551.12R-T6GX24	0,079 - 0,236	0,236	0,750	0,750	0,874	5,74	1,264	5,594	GX24- ..
G1551.16R-T6GX24		0,236	1,000	1,000	1,122	5,778	1,301	5,632	
G1551.16L-T6GX24	0,079 - 0,236	0,236	1,000	1,000	1,122	5,778	1,301	5,632	GX24- ..

Square shank

 Dimensional drawing shows right-hand version. | Refer to the Walter online catalogue for more product information: [www.walter-tools.com](http://www.walter-tools.com) | Bodies and assembly parts are included in the scope of delivery

## Assembly parts

	s [inch]	0.079 - 0.236
	Clamping screw for grooving insert Tightening torque	FS2118 (T20IP) 3,688 lbs
	Allen key	FS1464 (T20IP)

## Accessories

	s [inch]	0.079 - 0.236
	Torque screwdriver, analogue	FS2004
	Torque screwdriver, digital	FS2248
	Interchangeable blade	FS2015 (T20IP)

# Deep parting blade

**G1042** 

## Walter Cut

– Self-clamping system

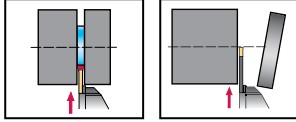

A2

### Tool

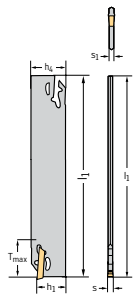

Designation	s mm	T <sub>max</sub> mm	h <sub>4</sub> mm	l <sub>1</sub> mm	h <sub>1</sub> mm	s <sub>1</sub> mm	Type
G1042.26N-2T40GX24	2	40	26	108	21,1	1,5	GX24-1E2 ..
G1042.32N-2T50GX24		50	32	149	24,8	1,5	
G1042.26N-3T40GX24	3	40	26	108	21	2,3	GX24-2E3 .. GX24-2F3 ..
G1042.32N-3T50GX24		50	32	149	24,7	2,3	
G1042.26N-4T40GX24	4	40	26	108	20,9	3,2	GX24-3E4 .. GX24-3F4 ..
G1042.32N-4T50GX24		50	32	149	24,6	3,2	
G1042.32N-5T60GX24	5	60	32	149	24,5	3,9	GX24-3E5 .. GX24-3F5 ..
G1042.32N-6T60GX24	6	60	32	149	24,4	4,7	GX24-4E6 ..

 Refer to the Walter online catalogue for more product information: [www.walter-tools.com](http://www.walter-tools.com)

### Accessories

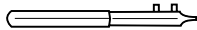
	s (mm)	2-6
 Mounting wrench for grooving insert		FS1494

# Reinforced parting blade

**G1041** 

## Walter Cut



– Screw clamping

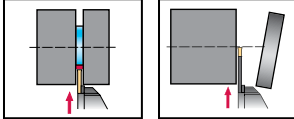

### Tool

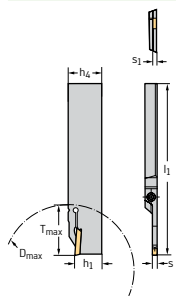

Designation	s mm	T <sub>max</sub> mm	D <sub>max</sub> mm	h <sub>4</sub> mm	l <sub>1</sub> mm	h <sub>1</sub> mm	s <sub>1</sub> mm	Type
G1041.26R-2T23GX24	2	23	46	26	110	21	1,5	GX24-1E2 ..
G1041.32R-2T32GX24		32	65	32	110	24,6	1,5	
G1041.26R-3T23GX24	3	23	46	26	110	21	2,2	GX24-2E3 .. GX24-2F3 ..
G1041.32R-3T23GX24		23	46	32	110	24,6	2,2	
G1041.32R-3T32GX24		32	65	32	110	24,6	2,2	
G1041.32R-4T32GX24	4	32	65	32	110	24,6	3,1	GX24-3E4 .. GX24-3F4 ..
G1041.26L-2T23GX24	2	23	46	26	110	21	1,5	GX24-1E2 ..
G1041.32L-2T32GX24		32	65	32	110	24,6	1,5	
G1041.26L-3T23GX24	3	23	46	26	110	21	2,2	GX24-2E3 .. GX24-2F3 ..
G1041.32L-3T23GX24		23	46	32	110	24,6	2,2	
G1041.32L-3T32GX24		32	65	32	110	24,6	2,2	
G1041.32L-4T32GX24	4	32	65	32	110	24,6	3,1	GX24-3E4 .. GX24-3F4 ..

Dimensional drawing shows right-hand version. | Refer to the Walter online catalogue for more product information: [www.walter-tools.com](http://www.walter-tools.com) | Bodies and assembly parts are included in the scope of delivery

### Assembly parts

	s [mm]	2-4
	Clamping screw for grooving insert Tightening torque	FS2164 (T15IP) 3,5 Nm

### Accessories

	s [mm]	2-4
	Screwdriver for grooving insert	FS1485 (T15IP)
	Torque screwdriver, analogue	FS2003
	Torque screwdriver, digital	FS2248
	Interchangeable blade	FS2014 (T15IP)



## Reinforced parting blade

G1041...-P

### Walter Cut

- Screw clamping
- Precision cooling



A2

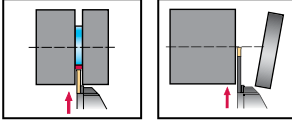

### Tool

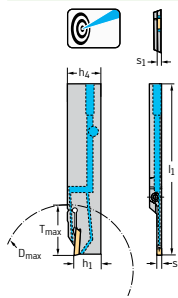

Designation	s mm	T <sub>max</sub> mm	D <sub>max</sub> mm	h <sub>4</sub> mm	l <sub>1</sub> mm	h <sub>1</sub> mm	s <sub>1</sub> mm	Type
G1041.26R-3T23GX24-P	3	23	46	26	110	21	2,2	GX24-2E3 .. GX24-2F3 ..
G1041.32R-3T23GX24-P		23	46	32	110	24,6	2,2	
G1041.32R-3T32GX24-P		32	65	32	110	24,6	2,2	GX34-2E3 ..
G1041.32R-3T33GX34-P		33	65	32	110	24,6	2,4	
G1041.32R-4T32GX24-P	4	32	65	32	110	24,6	3,1	GX24-3E4 .. GX24-3F4 ..
G1041.32R-4T33GX34-P		33	65	32	110	24,6	3,3	
G1041.26L-3T23GX24-P	3	23	46	26	110	21	2,2	GX24-2E3 .. GX24-2F3 ..
G1041.32L-3T23GX24-P		23	46	32	110	24,6	2,2	
G1041.32L-3T32GX24-P		32	65	32	110	24,6	2,2	GX34-2E3 ..
G1041.32L-3T33GX34-P		33	65	32	110	24,6	2,4	
G1041.32L-4T32GX24-P	4	32	65	32	110	24,6	3,1	GX24-3E4 .. GX24-3F4 ..

Dimensional drawing shows right-hand version. | The maximum recommended coolant pressure is 80 bar (1160 psi) | Refer to the Walter online catalogue for more product information: [www.walter-tools.com](http://www.walter-tools.com) | Bodies and assembly parts are included in the scope of delivery

### Assembly parts

	s [mm]	3-4
Clamping screw for grooving insert Tightening torque		FS2164 (T15IP) 3,5 Nm

### Accessories

	s [mm]	3-4
Screwdriver for grooving insert		FS1485 (T15IP)
Torque screwdriver, analogue		FS2003
Torque screwdriver, digital		FS2248
Interchangeable blade		FS2014 (T15IP)

## Reinforced parting blade – Contra

 G1041...C 

## Walter Cut



– Screw clamping

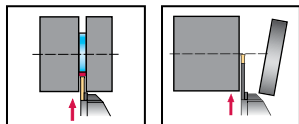

## Tool

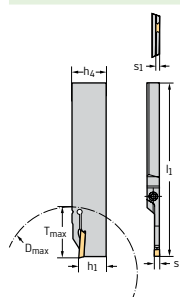

Designation	s mm	T <sub>max</sub> mm	D <sub>max</sub> mm	h <sub>4</sub> mm	l <sub>1</sub> mm	h <sub>1</sub> mm	s <sub>1</sub> mm	Type
G1041.26R-2T23GX24C	2	23	46	26	110	21	1,5	GX24-1E2 ..
G1041.32R-2T32GX24C		32	65	32	110	24,6	1,5	
G1041.26R-3T23GX24C	3	23	46	26	110	21	2,2	GX24-2E3 .. GX24-2F3 ..
G1041.32R-3T23GX24C		23	46	32	110	24,6	2,2	
G1041.32R-3T32GX24C		32	65	32	110	24,6	2,2	
G1041.32R-4T32GX24C	4	32	65	32	110	24,6	3,1	GX24-3E4 .. GX24-3F4 ..
G1041.26L-2T23GX24C	2	23	46	26	110	21	1,5	GX24-1E2 ..
G1041.32L-2T32GX24C		32	65	32	110	24,6	1,5	
G1041.26L-3T23GX24C	3	23	46	26	110	21	2,2	GX24-2E3 .. GX24-2F3 ..
G1041.32L-3T23GX24C		23	46	32	110	24,6	2,2	
G1041.32L-3T32GX24C		32	65	32	110	24,6	2,2	
G1041.32L-4T32GX24C	4	32	65	32	110	24,6	3,1	GX24-3E4 .. GX24-3F4 ..

 Dimensional drawing shows right-hand version. | Refer to the Walter online catalogue for more product information: [www.walter-tools.com](http://www.walter-tools.com) | Bodies and assembly parts are included in the scope of delivery

## Assembly parts

	s [mm]	2-4
Clamping screw for grooving insert Tightening torque		FS2164 (T15IP) 3,5 Nm

## Accessories

	s [mm]	2-4
Screwdriver for grooving insert		FS1485 (T15IP)
Torque screwdriver, analogue		FS2003
Torque screwdriver, digital		FS2248
Interchangeable blade		FS2014 (T15IP)

## Reinforced parting blade – Contra

G1041...C-P mm

## Walter Cut

- Screw clamping
- Precision cooling



A2

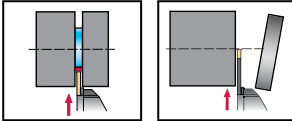

## Tool

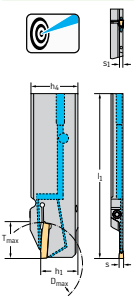

Designation	s mm	T <sub>max</sub> mm	D <sub>max</sub> mm	h <sub>4</sub> mm	l <sub>1</sub> mm	h <sub>1</sub> mm	s <sub>1</sub> mm	Type
G1041.32R-2T23GX24C-P	2	23	46	32	110	24,6	1,5	GX24-1E2 ..
G1041.26R-3T23GX24C-P	3	23	46	26	110	21	2,2	GX24-2E3 ..
G1041.32R-3T23GX24C-P								GX24-2F3 ..
G1041.32R-3T32GX24C-P								
G1041.32R-3T33GX34C-P								
G1041.32R-4T32GX24C-P	4	32	65	32	110	24,6	3,1	GX24-3E4 ..
G1041.32R-4T33GX34C-P								GX24-3F4 ..
G1041.32L-2T23GX24C-P								GX34-3E4 ..
G1041.26L-3T23GX24C-P	3	23	46	26	110	21	2,2	GX24-2E3 ..
G1041.32L-3T23GX24C-P								GX24-2F3 ..
G1041.32L-3T32GX24C-P								
G1041.32L-3T33GX34C-P								
G1041.32L-4T32GX24C-P	4	32	65	32	110	24,6	3,1	GX24-3E4 ..
G1041.32L-4T33GX34C-P								GX24-3F4 ..

Dimensional drawing shows right-hand version. | The maximum recommended coolant pressure is 80 bar (1160 psi) | Refer to the Walter online catalogue for more product information: [www.walter-tools.com](http://www.walter-tools.com) | Bodies and assembly parts are included in the scope of delivery

## Assembly parts

	s [mm]	2–4
	Clamping screw for grooving insert Tightening torque	FS2164 (T15IP) 3,5 Nm

## Accessories

	s [mm]	2–4
	Screwdriver for grooving insert	FS1485 (T15IP)
	Torque screwdriver, analogue	FS2003
	Torque screwdriver, digital	FS2248
	Interchangeable blade	FS2014 (T15IP)

# Deep parting blade

 XLCFN 

## Walter Cut



– Screw clamping

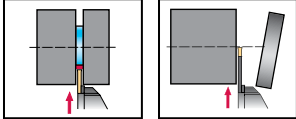

### Tool

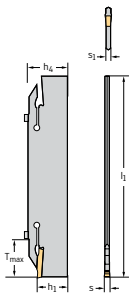

Designation	s mm	T <sub>max</sub> mm	h <sub>4</sub> mm	h <sub>1</sub> mm	h <sub>1</sub> mm	s <sub>1</sub> mm	Type
XLCFN3203-GX24-2S	3	21	32	179	24,2	2,1	GX24-2E3 .. GX24-2F3 ..
XLCFN3204-GX24-3S	4	21	32	179	24,2	3	GX24-3E4 .. GX24-3F4 ..
XLCFN3206-GX24-4S	6	21	32	179	24,2	4,2	GX24-4E6 ..

 Refer to the Walter online catalogue for more product information: [www.walter-tools.com](http://www.walter-tools.com) | Bodies and assembly parts are included in the scope of delivery

### Assembly parts

	s [mm]	3-6
Clamping screw for grooving insert Tightening torque		FS1342 (T15) 2 Nm

### Accessories

	s [mm]	3-6
Handle key for grooving insert		FS1047 (T15)

## Grooving module – Radial grooving

G1634-P

### Walter Cut

- Screw clamping
- Replacement module

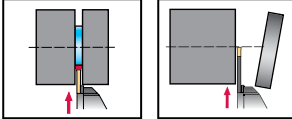

A2

### Tool

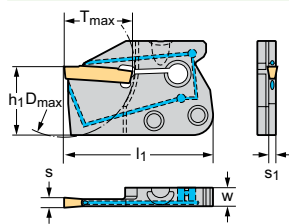

Designation	s mm	T <sub>max</sub> mm	D <sub>max</sub> mm	h <sub>1</sub> mm	W mm	l <sub>1</sub> mm	s <sub>1</sub> mm	Module size	Type
G1634-33R-2T21GX24-P	2	21	42	24	7,2	49	1,5	E33	GX24-1E2 ..
G1634-33L-2T21GX24-P	2	21	42	24	7,2	49	1,5	E33	GX24-1E2 ..
G1634-33L-3T21GX24-P	3	21	42	24	7,2	49	2,4	E33	GX24-2E3 .. GX24-2F3 ..

Dimensional drawing shows right-hand version. | If no D<sub>2</sub> or D<sub>max</sub> is specified, there is no diameter limit on the tool. | The maximum recommended coolant pressure is 150 bar (2175 psi) | If a clamping wedge is used, please use screw FS2622 | Refer to the Walter online catalogue for more product information: [www.walter-tools.com](http://www.walter-tools.com)

## Grooving module – Radial grooving

**G1634-P** mm

### Walter Cut

- Screw clamping
- Replacement module

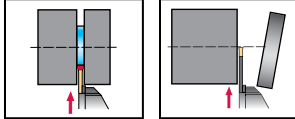

### Tool

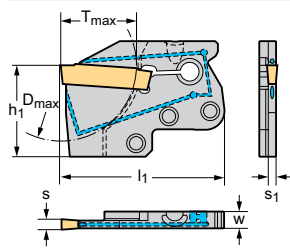

Designation	s mm	T <sub>max</sub> mm	D <sub>max</sub> mm	h <sub>1</sub> mm	W mm	l <sub>1</sub> mm	s <sub>1</sub> mm	Module size	Type
G1634-43R-3T27GX34-P	3	27	52	24	7,2	55	2,4	E43	GX34-2E3 ..
G1634-43R-3T33GX34-P		33	65	24	7,2	61	2,4	E43	
G1634-43L-3T27GX34-P	3	27	52	24	7,2	55	2,4	E33	GX34-2E3 ..
G1634-43L-3T33GX34-P		33	65	24	7,2	61	2,4	E43	
G1634-43L-4T33GX34-P	4	33	65	24	7,2	61	3,3	E43	GX34-3E4 ..

Dimensional drawing shows right-hand version. | If no D<sub>2</sub> or D<sub>max</sub> is specified, there is no diameter limit on the tool. | The maximum recommended coolant pressure is 150 bar (2175 psi) | If a clamping wedge is used, please use screw FS2622 | Refer to the Walter online catalogue for more product information: [www.walter-tools.com](http://www.walter-tools.com)

## Grooving module – Radial grooving

G1332 mm

### Walter Cut

- Self-clamping system
- Replacement module

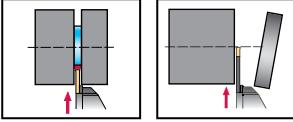

### Tool

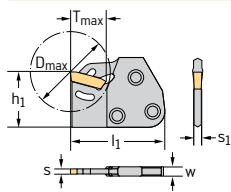

Designation	s mm	T <sub>max</sub> mm	D <sub>max</sub> mm	h <sub>1</sub> mm	W mm	l <sub>1</sub> mm	s <sub>1</sub> mm	Type
G1332.IMR-GAD3N-GX24	3	15	32	24	4	52	2,2	GX24-2E3 .. GX24-2F3 ..

Refer to the Walter online catalogue for more product information: [www.walter-tools.com](http://www.walter-tools.com)

### Accessories

	s [mm]	
	3	Mounting wrench for grooving insert
		FS1494

## Grooving module – Radial grooving

 MSS...E... 

## Walter Cut

– Screw clamping

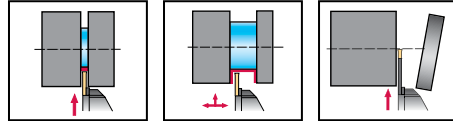

Tool	Designation	s mm	T <sub>max</sub> mm	D <sub>max</sub> mm	h <sub>1</sub> mm	W mm	l <sub>1</sub> mm	s <sub>1</sub> mm	Module size	Type
	MSS-E20R03-GX16-2	0.6 - 3	3	63	16	4,4	33	2	E20	GX16-0E ..
	MSS-E25R03-GX16-2		3	79	20	5,9	38	2	E25	GX16-1E ..
	MSS-E32R03-GX16-2		3	100	25,5		45	2	E32	GX16-2E ..
	MSS-E20R12-GX16-1	2	12	63	16	4,4	33	1,3	E20	GX16-1E2 ..
	MSS-E25R12-GX16-1		12	79	20	5,9	38	1,3	E25	
	MSS-E20R12-GX16-2	3	12	63	16	4,4	33	2	E20	GX16-2E3 ..
	MSS-E20R21-GX24-2		21	63	16	4,4	42	2	E20	GX24-2E3 .. GX24-2F3 ..
	MSS-E25R12-GX16-2		12	79	20	5,9	38	2	E25	GX16-2E3 ..
	MSS-E25R21-GX24-2		21	79	20	5,9	47	2	E25	GX24-2E3 .. GX24-2F3 ..
	MSS-E32R12-GX16-2		12	100	25,5		45	2	E32	GX16-2E3 ..
	MSS-E32R21-GX24-2		21	100	25,5		54	2	E32	GX24-2E3 .. GX24-2F3 ..
	MSS-E20R12-GX16-3	4 - 5	12	63	16	4,4	33	3	E20	GX16-3E ..
	MSS-E25R12-GX16-3		12	79	20	5,9	38	3	E25	
	MSS-E25R21-GX24-3		21	79	20	5,9	47	3	E25	GX24-3E .. GX24-3F ..
	MSS-E32R12-GX16-3		12	100	25,5		45	3	E32	GX16-3E ..
	MSS-E32R21-GX24-3		21	100	25,5		54	3	E32	GX24-3E .. GX24-3F ..
	MSS-E25R12-GX16-4	6	12	79	20	5,9	38	4,2	E25	GX16-4E6 ..
	MSS-E25R21-GX24-4		21	79	20	5,9	47	4,2	E25	GX24-4E6 ..
MSS-E32R21-GX24-4	21		100	25,5		54	4,2	E32		
MSS-E25R21-GX24-5	8	21	79	20	5,9	47	5,9	E25	GX24-5R ..	
MSS-E20L03-GX16-2	0.6 - 3	3	63	16	4,4	33	2	E20	GX16-0E ..	
MSS-E25L03-GX16-2		3	79	20	5,9	38	2	E25	GX16-1E ..	
MSS-E32L03-GX16-2		3	100	25,5	5,9	45	2	E32	GX16-2E ..	
MSS-E20L12-GX16-1	2	12	63	16	4,4	33	1,3	E20	GX16-1E2 ..	
MSS-E25L12-GX16-1		12	79	20	5,9	38	1,3	E25		
MSS-E20L12-GX16-2	3	12	63	16	4,4	33	2	E20	GX16-2E3 ..	
MSS-E20L21-GX24-2		21	63	16	4,4	42	2	E20	GX24-2E3 .. GX24-2F3 ..	
MSS-E25L12-GX16-2		12	79	20	5,9	38	2	E25	GX16-2E3 ..	
MSS-E25L21-GX24-2		21	79	20	5,9	47	2	E25	GX24-2E3 .. GX24-2F3 ..	
MSS-E32L12-GX16-2		12	100	25,5	5,9	45	2	E32	GX16-2E3 ..	
MSS-E20L12-GX16-3	4 - 5	12	63	16	4,4	33	3	E20	GX16-3E ..	
MSS-E25L12-GX16-3		12	79	20	5,9	38	3	E25		
MSS-E25L21-GX24-3		21	79	20	5,9	47	3	E25	GX24-3E .. GX24-3F ..	
MSS-E32L12-GX16-3		12	100	25,5	5,9	45	3	E32	GX16-3E ..	
MSS-E32L21-GX24-3		21	100	25,5	5,9	54	3	E32	GX24-3E .. GX24-3F ..	
MSS-E25L12-GX16-4	6	12	79	20	5,9	38	4,2	E25	GX16-4E6 ..	
MSS-E25L21-GX24-4		21	79	20	5,9	47	4,2	E25	GX24-4E6 ..	
MSS-E32L21-GX24-4		21	100	25,5	5,9	54	4,2	E32		
MSS-E25L21-GX24-5	8	21	79	20	5,9	47	5,9	E25	GX24-5R ..	

 Dimensional drawing shows right-hand version. | Refer to the Walter online catalogue for more product information: [www.walter-tools.com](http://www.walter-tools.com)



## Shank tool – Axial grooving

G1111 

Walter Cut



A2

– Screw clamping

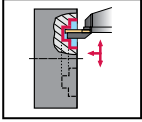

## Tool

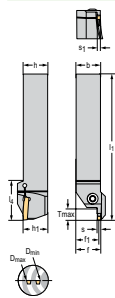

Square shank

Designation	s mm	T <sub>max</sub> mm	D <sub>min</sub> mm	D <sub>max</sub> mm	h = h <sub>1</sub> mm	b mm	f <sub>1</sub> mm	l <sub>1</sub> mm	l <sub>4</sub> mm	s <sub>1</sub> mm	Type
G1111.2525R-3T12-034GX24	3	12	34	44	25	25	24,7	150	40	2,4	GX24-2E3 .. GX24-2F3 ..
G1111.2525R-3T12-042GX24		12	42	60	25	25	24,7	150	40	2,4	
G1111.2525R-3T12-054GX24		12	54	75	25	25	24,6	150	40	2,4	
G1111.2525R-3T12-067GX24		12	67	100	25	25	24,6	150	40	2,4	
G1111.2525R-3T12-090GX24		12	90	160	25	25	24,6	150	40	2,4	
G1111.2525R-3T12-130GX24		12	130	300	25	25	24,6	150	40	2,4	
G1111.2525R-3T19-054GX24		19	54	75	25	25	24,7	152	42	2,4	
G1111.2525R-3T22-067GX24		22	67	100	25	25	24,7	154	44	2,3	
G1111.2525R-3T22-090GX24		22	90	160	25	25	24,6	154	44	2,3	
G1111.2525R-3T22-130GX24		22	130	300	25	25	24,6	154	44	2,3	
G1111.2525R-4T12-040GX24	4	12	40	60	25	25	24,1	150	40	3,3	GX24-3E4 .. GX24-3F4 ..
G1111.2525R-4T12-052GX24		12	52	72	25	25	24,1	150	40	3,3	
G1111.2525R-4T12-064GX24		12	64	100	25	25	24,1	150	40	3,3	
G1111.2525R-4T12-092GX24		12	92	140	25	25	24,1	150	40	3,3	
G1111.2525R-4T12-132GX24		12	132	230	25	25	24,1	150	40	3,3	
G1111.2525R-4T12-220GX24		12	220	500	25	25	24,1	150	40	3,3	
G1111.2525R-4T20-040GX24		20	40	60	25	25	24,3	152	42	3,3	
G1111.2525R-4T20-052GX24		20	52	72	25	25	24,2	152	42	3,3	
G1111.2525R-4T25-064GX24		25	64	100	25	25	24,1	156	46	3,3	
G1111.2525R-4T25-092GX24		25	92	140	25	25	24,1	156	46	3,3	
G1111.2525R-4T25-132GX24	25	132	230	25	25	24,1	156	46	3,3		
G1111.2525R-4T25-220GX24	25	220	500	25	25	24,1	156	46	3,3		
G1111.2525R-5T12-040GX24	5	12	40	70	25	25	23,7	150	40	4,2	GX24-3E5 .. GX24-3F5 ..
G1111.2525R-5T12-060GX24		12	60	95	25	25	23,7	150	40	4,2	
G1111.2525R-5T12-085GX24		12	85	130	25	25	23,7	150	40	4,2	
G1111.2525R-5T12-120GX24		12	120	180	25	25	23,7	150	40	4,2	
G1111.2525R-5T12-175GX24		12	175	500	25	25	23,6	150	40	4,1	
G1111.2525R-5T20-040GX24		20	40	70	25	25	23,8	152	42	4,2	
G1111.2525R-5T20-060GX24		20	60	95	25	25	23,7	152	42	4,2	
G1111.2525R-5T25-085GX24		25	85	130	25	25	23,7	156	46	4,2	
G1111.2525R-5T25-120GX24		25	120	180	25	25	23,7	156	46	4,2	
G1111.2525R-5T25-175GX24		25	175	500	25	25	23,7	156	46	4,2	
G1111.2525R-6T12-040GX24	6	12	40	70	25	25	23,2	150	40	5	GX24-4E6 ..
G1111.2525R-6T12-058GX24		12	58	100	25	25	23,2	150	40	5	
G1111.2525R-6T12-088GX24		12	88	180	25	25	23,2	150	40	5	
G1111.2525R-6T12-168GX24		12	168	400	25	25	23,2	150	40	5	
G1111.2525R-6T20-040GX24		20	40	70	25	25	23,3	152	42	5	
G1111.2525R-6T25-058GX24		25	58	100	25	25	23,2	156	46	5	

Dimensional drawing shows right-hand version. | Refer to the Walter online catalogue for more product information: [www.walter-tools.com](http://www.walter-tools.com) | Bodies and assembly parts are included in the scope of delivery

A2

## Tool

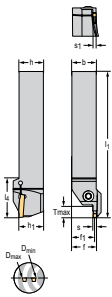

Square shank



Designation	s mm	T <sub>max</sub> mm	D <sub>min</sub> mm	D <sub>max</sub> mm	h = h <sub>1</sub> mm	b mm	f <sub>1</sub> mm	l <sub>1</sub> mm	l <sub>4</sub> mm	s <sub>1</sub> mm	Type	
G1111.2525R-6T25-088GX24	6	25	88	180	25	25	23,2	156	46	5	GX24-4E6 ..	
G1111.2525R-6T25-168GX24		25	168	400	25	25	23,2	156	46	5		
G1111.2525L-3T12-034GX24	3	12	34	44	25	25	24,7	150	40	2,4	GX24-2E3 .. GX24-2F3 ..	
G1111.2525L-3T12-042GX24		12	42	60	25	25	24,7	150	40	2,4		
G1111.2525L-3T12-054GX24		12	54	75	25	25	24,6	150	40	2,4		
G1111.2525L-3T12-067GX24		12	67	100	25	25	24,6	150	40	2,4		
G1111.2525L-3T12-090GX24		12	90	160	25	25	24,6	150	40	2,4		
G1111.2525L-3T12-130GX24		12	130	300	25	25	24,6	150	40	2,4		
G1111.2525L-3T19-054GX24		19	54	75	25	25	24,7	152	42	2,4		
G1111.2525L-3T22-067GX24		22	67	100	25	25	24,7	154	44	2,4		
G1111.2525L-3T22-090GX24		22	90	160	25	25	24,6	154	44	2,4		
G1111.2525L-3T22-130GX24		22	130	300	25	25	24,6	154	44	2,4		
G1111.2525L-4T12-040GX24		4	12	40	60	25	25	24,1	150	40	3,3	GX24-3E4 .. GX24-3F4 ..
G1111.2525L-4T12-052GX24			12	52	72	25	25	24,1	150	40	3,3	
G1111.2525L-4T12-064GX24	12		64	100	25	25	24,1	150	40	3,3		
G1111.2525L-4T12-092GX24	12		92	140	25	25	24,1	150	40	3,3		
G1111.2525L-4T12-132GX24	12		132	230	25	25	24,1	150	40	3,3		
G1111.2525L-4T12-220GX24	12		220	500	25	25	24,1	150	40	3,3		
G1111.2525L-4T20-040GX24	20		40	60	25	25	24,3	152	42	3,3		
G1111.2525L-4T20-052GX24	20		52	72	25	25	24,2	152	42	3,3		
G1111.2525L-4T25-064GX24	25		64	100	25	25	24,1	156	46	3,3		
G1111.2525L-4T25-092GX24	25		92	140	25	25	24,1	156	46	3,3		
G1111.2525L-4T25-132GX24	25		132	230	25	25	24,1	156	46	3,3		
G1111.2525L-4T25-220GX24	25		220	500	25	25	24,1	156	46	3,3		
G1111.2525L-5T12-040GX24	5	12	40	70	25	25	23,7	150	40	4,2	GX24-3E5 .. GX24-3F5 ..	
G1111.2525L-5T12-060GX24		12	60	95	25	25	23,7	150	40	4,2		
G1111.2525L-5T12-085GX24		12	85	130	25	25	23,7	150	40	4,2		
G1111.2525L-5T12-120GX24		12	120	180	25	25	23,7	150	40	4,2		
G1111.2525L-5T12-175GX24		12	175	500	25	25	23,6	150	40	4,1		
G1111.2525L-5T20-040GX24		20	40	70	25	25	23,8	152	42	4,2		
G1111.2525L-5T20-060GX24		20	60	95	25	25	23,7	152	42	4,2		
G1111.2525L-5T25-085GX24		25	85	130	25	25	23,7	156	46	4,2		
G1111.2525L-5T25-120GX24		25	120	180	25	25	23,7	156	46	4,2		
G1111.2525L-5T25-175GX24		25	175	500	25	25	23,2	156	46	4,2		
G1111.2525L-6T12-040GX24		6	12	40	70	25	25	23,2	150	40	5	GX24-4E6 ..
G1111.2525L-6T12-058GX24			12	58	100	25	25	23,2	150	40	5	
G1111.2525L-6T12-088GX24	12		88	180	25	25	23,2	150	40	5		
G1111.2525L-6T12-168GX24	12		168	400	25	25	23,2	150	40	5		
G1111.2525L-6T20-040GX24	20		40	70	25	25	23,3	152	42	5		
G1111.2525L-6T25-058GX24	25		58	100	25	25	23,2	156	46	5		
G1111.2525L-6T25-088GX24	25		88	180	25	25	23,2	156	46	5		
G1111.2525L-6T25-168GX24	25		168	400	25	25	23,2	156	46	5		

Dimensional drawing shows right-hand version. | Refer to the Walter online catalogue for more product information: [www.walter-tools.com](http://www.walter-tools.com) | Bodies and assembly parts are included in the scope of delivery

## Assembly parts

	s [mm] h = h <sub>1</sub> [mm]	3-6 25
	Clamping screw for grooving insert Tightening torque	FS2118 (T20IP) 5 Nm
	Allen key	FS1464 (T20IP)

## Accessories

	s [mm] h = h <sub>1</sub> [mm]	3-6 25
	Torque screwdriver, analogue	FS2003
	Torque screwdriver, digital	FS2248
	Interchangeable blade	FS2015 (T20IP)

A2

# Shank tool – Axial grooving

**G1111...-P** mm

## Walter Cut

- Precision cooling
- Screw clamping

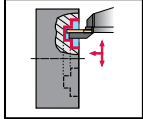

### Tool

		s	T <sub>max</sub>	D <sub>min</sub>	D <sub>max</sub>	h = h <sub>1</sub>	b	f <sub>1</sub>	l <sub>1</sub>	l <sub>4</sub>	s <sub>1</sub>	Type
		mm	mm	mm	mm	mm	mm	mm	mm	mm	mm	
	Designation											
	G1111.2525R-5T33060GX24P	5	33	60	95	25	25	23,7	145	50	4,2	GX24-3E5 .. GX24-3F5 ..
	G1111.2525R-5T33085GX24P		33	85	130	25	25	23,7	145	50	4,2	
	G1111.2525R-5T33120GX24P		33	120	180	25	25	23,7	145	50	4,2	
	G1111.2525R-5T33175GX24P		33	175	500	25	25	23,7	145	50	4,2	
	G1111.2525L-5T33060GX24P	5	33	60	95	25	25	23,7	145	50	4,2	GX24-3E5 .. GX24-3F5 ..
	G1111.2525L-5T33085GX24P		33	85	130	25	25	23,7	145	50	4,2	
	G1111.2525L-5T33120GX24P		33	120	180	25	25	23,7	145	50	4,2	
G1111.2525L-5T33175GX24P		33	175	500	25	25	23,7	145	50	4,2		

Square shank

Dimensional drawing shows right-hand version. | The maximum recommended coolant pressure is 150 bar (2175 psi) |  $f = f_1 + s/2$  | Refer to the Walter online catalogue for more product information: [www.walter-tools.com](http://www.walter-tools.com) | Bodies and assembly parts are included in the scope of delivery

### Assembly parts

		s [mm]	5
	Clamping screw for grooving insert Tightening torque		FS2118 (T20IP) 5 Nm
	G 1/8" threaded plug		FS2258 (SW 2)
	M6 threaded plug		FS2288 (SW 3)
	Allen key		FS1464 (T20IP)

### Accessories

		s [mm]	5
	Torque screwdriver, analogue		FS2003
	Torque screwdriver, digital		FS2248
	Interchangeable blade		FS2015 (T20IP)

## Shank tool – Axial grooving

G1111 inch

Walter Cut



– Screw clamping

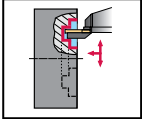

## Tool

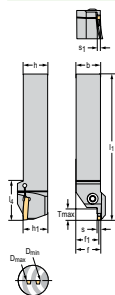

Square shank



Designation	s inch	T <sub>max</sub> inch	D <sub>min</sub> inch	D <sub>max</sub> inch	h = h <sub>1</sub> inch	b inch	f <sub>1</sub> inch	l <sub>1</sub> inch	l <sub>2</sub> inch	s <sub>1</sub> inch	Type
G1111.16R-3T12-034GX24	0,118	0,472	1,339	1,732	1,000	1,000	0,989	5,906	1,575	0,094	GX24-2E3 .. GX24-2F3 ..
G1111.16R-3T12-042GX24		0,472	1,654	2,362	1,000	1,000	0,987	5,906	1,654	0,094	
G1111.16R-3T19-054GX24		0,748	2,126	2,953	1,000	1,000	0,987	5,984	1,654	0,094	
G1111.16R-3T22-067GX24		0,866	2,638	3,937	1,000	1,000	0,987	6,063	1,732	0,091	
G1111.16R-3T22-090GX24		0,866	3,543	6,299	1,000	1,000	0,984	6,063	1,732	0,091	
G1111.16R-3T22-130GX24		0,866	5,118	11,811	1,000	1,000	0,984	6,063	1,732	0,091	
G1111.16R-4T20-040GX24	0,157	0,787	1,575	2,756	1,000	1,000	0,97	5,984	1,654	0,130	GX24-3E4 .. GX24-3F4 ..
G1111.16R-4T20-052GX24		0,787	2,047	2,835	1,000	1,000	0,968	5,984	1,654	0,130	
G1111.16R-4T25-064GX24		0,984	2,520	3,937	1,000	1,000	0,966	6,142	1,811	0,130	
G1111.16R-4T25-092GX24		0,984	3,622	5,512	1,000	1,000	0,963	6,142	1,811	0,130	
G1111.16R-4T25-132GX24		0,984	5,197	9,055	1,000	1,000	0,963	6,142	1,811	0,130	
G1111.16R-4T25-220GX24		0,984	8,661	19,685	1,000	1,000	0,963	6,142	1,811	0,130	
G1111.16R-6T20-040GX24	0,236	0,787	1,575	2,756	1,000	1,000	0,933	5,984	1,654	0,201	GX24-4E6 ..
G1111.16R-6T25-058GX24		0,984	2,283	3,937	1,000	1,000	0,930	6,142	1,811	0,197	
G1111.16R-6T25-088GX24		0,984	3,465	7,087	1,000	1,000	0,927	6,142	1,811	0,197	
G1111.16R-6T25-168GX24		0,984	6,614	15,748	1,000	1,000	0,927	6,142	1,811	0,197	
G1111.16L-3T12-034GX24	0,118	0,472	1,339	1,732	1,000	1,000	0,989	5,906	1,575	0,094	GX24-2E3 .. GX24-2F3 ..
G1111.16L-3T12-042GX24		0,472	1,654	2,362	1,000	1,000	0,987	5,906	1,654	0,094	
G1111.16L-3T19-054GX24		0,748	2,126	2,953	1,000	1,000	0,987	5,984	1,654	0,094	
G1111.16L-3T22-067GX24		0,866	2,638	3,937	1,000	1,000	0,987	6,063	1,732	0,091	
G1111.16L-3T22-090GX24		0,866	3,543	6,299	1,000	1,000	0,984	6,063	1,732	0,091	
G1111.16L-3T22-130GX24		0,866	5,118	11,811	1,000	1,000	0,984	6,063	1,732	0,091	
G1111.16L-4T20-040GX24	0,157	0,787	1,575	2,756	1,000	1,000	0,97	5,984	1,654	0,130	GX24-3E4 .. GX24-3F4 ..
G1111.16L-4T20-052GX24		0,787	2,047	2,835	1,000	1,000	0,968	5,984	1,654	0,130	
G1111.16L-4T25-064GX24		0,984	2,520	3,937	1,000	1,000	0,966	6,142	1,811	0,130	
G1111.16L-4T25-092GX24		0,984	3,622	5,512	1,000	1,000	0,963	6,142	1,811	0,130	
G1111.16L-4T25-132GX24		0,984	5,197	9,055	1,000	1,000	0,963	6,142	1,811	0,130	
G1111.16L-4T25-220GX24		0,984	8,661	19,685	1,000	1,000	0,963	6,142	1,811	0,130	
G1111.16L-6T20-040GX24	0,236	0,787	1,575	2,756	1,000	1,000	0,933	5,984	1,654	0,201	GX24-4E6 ..
G1111.16L-6T25-058GX24		0,984	2,283	3,937	1,000	1,000	0,930	6,142	1,811	0,197	
G1111.16L-6T25-088GX24		0,984	3,465	7,087	1,000	1,000	0,927	6,142	1,811	0,197	
G1111.16L-6T25-168GX24		0,984	6,614	15,748	1,000	1,000	0,927	6,142	1,811	0,197	

Dimensional drawing shows right-hand version. | Refer to the Walter online catalogue for more product information: [www.walter-tools.com](http://www.walter-tools.com) | Bodies and assembly parts are included in the scope of delivery

## Assembly parts

	s [inch] h = h <sub>1</sub> [inch]	0,118–0,236 1
	Clamping screw for grooving insert Tightening torque	FS2118 (T20IP) 3,688 lbs
	Torx key	FS1464 (T20IP)

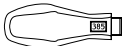
A2

Accessories		s [inch] h = h <sub>1</sub> [inch]	0,118–0,236 1
	Torque screwdriver, analogue		FS2004
	Torque screwdriver, digital		FS2248
	Interchangeable blade		FS2015 (T20IP)

## Grooving module – Axial grooving

MSS...E...A 

## Walter Cut

– Screw clamping

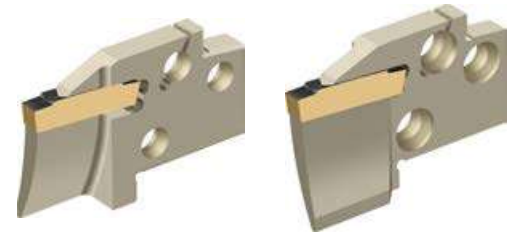
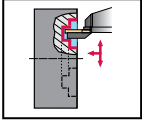

A2

## Tool

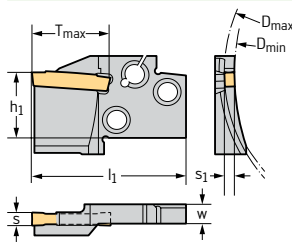

Designation	s mm	T <sub>max</sub> mm	D <sub>min</sub> mm	D <sub>max</sub> mm	h <sub>1</sub> mm	W mm	l <sub>1</sub> mm	s <sub>1</sub> mm	Module size	Type
MSS-E20R14-GX24-2A100150	3	14	100	150	16	4,4	42	2	E20	GX24-2E3 .. GX24-2F3 ..
MSS-E20R14-GX24-2A5070		14	50	70	16	4,4	42	2	E20	
MSS-E20R14-GX24-2A70100		14	70	100	16	4,4	42	2	E20	
MSS-E25R15-GX24-2A100150	3	15	100	150	20	5,9	47	2	E25	GX24-3E .. GX24-3F ..
MSS-E25R15-GX24-2A5070		15	50	70	20	5,9	47	2	E25	
MSS-E25R15-GX24-2A70100		15	70	100	20	5,9	47	2	E25	
MSS-E25R15-GX24-3A100150	4 - 5	15	100	150	20	5,9	47	3	E25	GX24-3E .. GX24-3F ..
MSS-E25R15-GX24-3A150300		15	150	300	20	5,9	47	3	E25	
MSS-E25R15-GX24-3A5070		15	50	70	20	5,9	47	3	E25	
MSS-E25R15-GX24-3A70100	4 - 5	15	70	100	20	5,9	47	3	E25	GX24-3E .. GX24-3F ..
MSS-E32R15-GX24-3A100150		15	100	150	25,5		54	3	E32	
MSS-E32R15-GX24-3A150300		15	150	300	25,5		54	3	E32	
MSS-E32R15-GX24-3A70100	4 - 5	15	70	100	25,5		54	3	E32	GX24-4E6 ..
MSS-E25R15-GX24-4A100150		15	100	150	20	5,9	47	4,2	E25	
MSS-E25R15-GX24-4A150300		15	150	300	20	5,9	47	4,2	E25	
MSS-E25R15-GX24-4A5070	6	15	50	70	20	5,9	47	4,2	E25	GX24-4E6 ..
MSS-E25R15-GX24-4A70100		15	70	100	20	5,9	47	4,2	E25	
MSS-E32R15-GX24-4A100150		15	100	150	25,5		54	4,2	E32	
MSS-E32R15-GX24-4A150300	6	15	150	300	25,5		54	4,2	E32	GX24-4E6 ..
MSS-E32R15-GX24-4A300900		15	300	900	25,5		54	4,2	E32	
MSS-E32R15-GX24-4A70100		15	70	100	25,5		54	4,2	E32	
MSS-E20L14-GX24-2A100150	3	14	100	150	16	4,4	42	2	E20	GX24-2E3 .. GX24-2F3 ..
MSS-E20L14-GX24-2A5070		14	50	70	16	4,4	42	2	E20	
MSS-E20L14-GX24-2A70100		14	70	100	16	4,4	42	2	E20	
MSS-E25L15-GX24-2A100150	3	15	100	150	20	5,9	47	2	E25	GX24-2E3 .. GX24-2F3 ..
MSS-E25L15-GX24-2A5070		15	50	70	20	5,9	47	2	E25	
MSS-E25L15-GX24-2A70100		15	70	100	20	5,9	47	2	E25	
MSS-E25L15-GX24-3A100150	4 - 5	15	100	150	20	5,9	47	3	E25	GX24-3E .. GX24-3F ..
MSS-E25L15-GX24-3A150300		15	150	300	20	5,9	47	3	E25	
MSS-E25L15-GX24-3A5070		15	50	70	20	5,9	47	3	E25	
MSS-E25L15-GX24-3A70100	4 - 5	15	70	100	20	5,9	47	3	E25	GX24-3E .. GX24-3F ..
MSS-E32L15-GX24-3A100150		15	100	150	25,5	5,9	54	3	E32	
MSS-E32L15-GX24-3A150300		15	150	300	25,5	5,9	54	3	E32	
MSS-E32L15-GX24-3A70100	4 - 5	15	70	100	25,5	5,9	54	3	E32	GX24-4E6 ..
MSS-E25L15-GX24-4A100150		15	100	150	20	5,9	47	4,2	E25	
MSS-E25L15-GX24-4A150300		15	150	300	20	5,9	47	4,2	E25	
MSS-E25L15-GX24-4A5070	6	15	50	70	20	5,9	47	4,2	E25	GX24-4E6 ..
MSS-E25L15-GX24-4A70100		15	70	100	20	5,9	47	4,2	E25	
MSS-E32L15-GX24-4A100150		15	100	150	25,5	5,9	54	4,2	E32	

Dimensional drawing shows right-hand version. | Refer to the Walter online catalogue for more product information: [www.walter-tools.com](http://www.walter-tools.com)

A2

Tool		s mm	T <sub>max</sub> mm	D <sub>min</sub> mm	D <sub>max</sub> mm	h <sub>1</sub> mm	W mm	l <sub>1</sub> mm	s <sub>1</sub> mm	Module size	Type
	MSS-E32L15-GX24-4A150300	6	15	150	300	25,5	5,9	54	4,2	E32	GX24-4E6 ..
	MSS-E32L15-GX24-4A300900		15	300	900	25,5	5,9	54	4,2	E32	
	MSS-E32L15-GX24-4A70100		15	70	100	25,5	5,9	54	4,2	E32	

 Dimensional drawing shows right-hand version. | Refer to the Walter online catalogue for more product information: [www.walter-tools.com](http://www.walter-tools.com)



## Grooving module – Axial grooving

MSS...E...C 

## Walter Cut

– Screw clamping

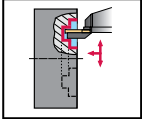

A2

## Tool

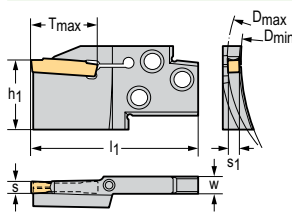

Designation	s mm	T <sub>max</sub> mm	D <sub>min</sub> mm	D <sub>max</sub> mm	h <sub>1</sub> mm	W mm	l <sub>1</sub> mm	s <sub>1</sub> mm	Module size	Type
MSS-E25R21-GX24-3C100150	4 - 5	21	100	150	20	6,2	60	3	E25	GX24-3E .. GX24-3F ..
MSS-E25R21-GX24-3C150300		21	150	300	20	6,2	60	3	E25	
MSS-E25R21-GX24-3C5070		21	50	70	20	6,2	60	3	E25	
MSS-E25R21-GX24-3C70100		21	70	100	20	6,2	60	3	E25	
MSS-E25R25-GX24-4C100150	6	25	100	150	20	6,2	60	4,2	E25	GX24-4E6 ..
MSS-E25R25-GX24-4C150300		25	150	300	20	6,2	60	4,2	E25	
MSS-E25R25-GX24-4C5070		25	50	70	20	6,2	60	4,2	E25	
MSS-E25R25-GX24-4C70100		25	70	100	20	6,2	60	4,2	E25	
MSS-E25L21-GX24-3C100150	4 - 5	21	100	150	20	6,2	60	3	E25	GX24-3E .. GX24-3F ..
MSS-E25L21-GX24-3C150300		21	150	300	20	6,2	60	3	E25	
MSS-E25L21-GX24-3C5070		21	50	70	20	6,2	60	3	E25	
MSS-E25L21-GX24-3C70100		21	70	100	20	6,2	60	3	E25	
MSS-E25L25-GX24-4C100150	6	25	100	150	20	6,2	60	4,2	E25	GX24-4E6 ..
MSS-E25L25-GX24-4C150300		25	150	300	20	6,2	60	4,2	E25	
MSS-E25L25-GX24-4C5070		25	50	70	20	6,2	60	4,2	E25	
MSS-E25L25-GX24-4C70100		25	70	100	20	6,2	60	4,2	E25	

Dimensional drawing shows right-hand version. | Refer to the Walter online catalogue for more product information: [www.walter-tools.com](http://www.walter-tools.com) | Bodies and assembly parts are included in the scope of delivery

## Assembly parts

	s [mm]	4 - 5-6
	Clamping screw for grooving insert Tightening torque	FS1342 (T15) 2 Nm
	Handle key for grooving insert	FS1047 (T15)

# Shank tool – Radial grooving

**G2012** mm

## Walter Cut



– Self-clamping system

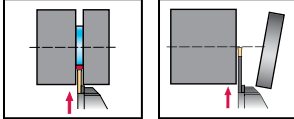

### Tool

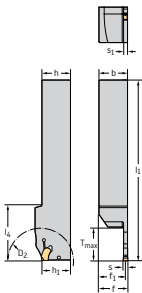

Designation	s mm	D <sub>2</sub> mm	T <sub>max</sub> mm	h = h <sub>1</sub> mm	b mm	f mm	l <sub>1</sub> mm	l <sub>4</sub> mm	s <sub>1</sub> mm	Type
G2012.2020R-1.5T15SX	1,5	38	15	20	20	19,4	120	25	1,2	SX-1E1
G2012.2525R-2T26SX	2	52	26	25	25	24,2	146	36	1,6	SX-2E2
G2012.2525R-3T33SX	3	65	33	25	25	23,8	150	43	2,5	SX-3E3
G2012.2020L-1.5T15SX	1,5	38	15	20	20	19,4	120	25	1,2	SX-1E1
G2012.2525L-2T26SX	2	52	26	25	25	24,2	146	36	1,6	SX-2E2
G2012.2525L-3T33SX	3	65	33	25	25	23,8	150	43	2,5	SX-3E3

Square shank

 Dimensional drawing shows right-hand version. |  $f = f_1 + s/2$  | Refer to the Walter online catalogue for more product information: [www.walter-tools.com](http://www.walter-tools.com)

### Accessories

	s [mm] h = h <sub>1</sub> [mm]	1,5 20	2-3 25
	Mounting wrench for grooving insert	FS2249	FS1494

## Shank tool – Radial grooving

G2012...-P 

## Walter Cut

- Self-clamping system
- Precision cooling



A2

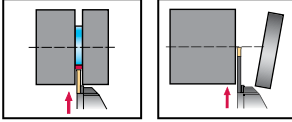

## Tool

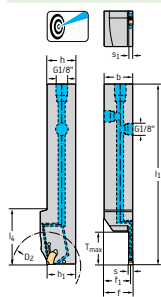

Square shank

Designation	s mm	D <sub>2</sub> mm	T <sub>max</sub> mm	h = h <sub>1</sub> mm	b mm	f <sub>1</sub> mm	l <sub>1</sub> mm	l <sub>4</sub> mm	s <sub>1</sub> mm	Type
G2012.1212R-2T16SX-P	2	38	16	12	12	11,2	120	25	1,6	SX-2E2
G2012.1616R-2T16SX-P		38	16	16	16	15,2	120	25	1,6	
G2012.1212R-3T16SX-P	3	38	16	12	12	10,8	120	25	2,5	SX-3E3
G2012.1616R-3T16SX-P		38	16	16	16	14,8	120	25	2,5	
G2012.1616R-3T26SX-P		68	26	16	16	14,8	120	33	2,5	
G2012.1212L-2T16SX-P	2	38	16	12	12	11,2	120	25	1,6	SX-2E2
G2012.1616L-2T16SX-P		38	16	16	16	15,2	120	25	1,6	
G2012.1212L-3T16SX-P	3	38	16	12	12	10,8	120	25	2,5	SX-3E3
G2012.1616L-3T16SX-P		38	16	16	16	14,8	120	25	2,5	
G2012.1616L-3T26SX-P		68	26	16	16	14,8	120	33	2,5	

Dimensional drawing shows right-hand version. |  $f = f_1 + s/2$  | The maximum recommended coolant pressure is 150 bar (2175 psi) | For  $T_{max}$  with diameters greater than  $D_2$ , see „Technical information – Grooving“ | Refer to the Walter online catalogue for more product information: [www.walter-tools.com](http://www.walter-tools.com) | Bodies and assembly parts are included in the scope of delivery

## Assembly parts

	s [mm]	2-3
	G 1/8" threaded plug	FS2258 (SW 2)

## Accessories

	s [mm] h = h <sub>1</sub> [mm]	2-3 12-16	3 16
	Mounting wrench for grooving insert	FS2249	FS2249

## Shank tool – Radial grooving

**G2012...-P** 

### Walter Cut

- Self-clamping system
- Precision cooling

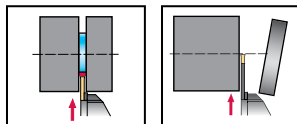

### Tool

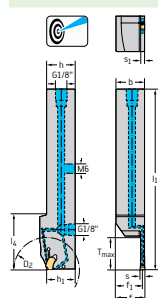

Square shank

Designation	s mm	D <sub>2</sub> mm	T <sub>max</sub> mm	h = h <sub>1</sub> mm	b mm	f <sub>1</sub> mm	l <sub>1</sub> mm	l <sub>4</sub> mm	s <sub>1</sub> mm	Type
G2012.2020R-2T20SX-P	2	68	20	20	20	19,2	120	36	1,6	SX-2E2
G2012.2020R-3T22SX-P	3	68	22	20	20	18,8	125	38	2,5	SX-3E3
G2012.2020R-3T33SX-P		68	33	20	20	18,8	120	38	2,5	
G2012.2525R-3T33SX-P		68	33	25	25	23,8	130	45	2,5	
G2012.2020R-4T33SX-P	4		33	20	20	18,3	130	48	3,4	SX-4E4
G2012.2525R-4T33SX-P			33	25	25	23,3	130	48	3,4	
G2012.2525R-5T40SX-P	5		40	25	25	22,9	145	52	4,3	SX-5E5
G2012.2525R-6T40SX-P	6		40	25	25	22,4	145	52	5,3	SX-6E6
G2012.2020L-2T20SX-P	2	68	20	20	20	19,2	120	36	1,6	SX-2E2
G2012.2020L-3T22SX-P	3	68	22	20	20	18,8	125	38	2,5	SX-3E3
G2012.2020L-3T33SX-P		68	33	20	20	18,8	120	38	2,5	
G2012.2525L-3T33SX-P		68	33	25	25	23,8	130	48	2,5	
G2012.2020L-4T33SX-P	4		33	20	20	18,3	130	48	3,4	SX-4E4
G2012.2525L-4T33SX-P			33	25	25	23,3	130	48	3,4	
G2012.2525L-5T40SX-P	5		40	25	25	22,9	145	52	4,3	SX-5E5
G2012.2525L-6T40SX-P	6		40	25	25	22,4	145	52	5,3	SX-6E6

Dimensional drawing shows right-hand version. |  $f = f_1 + s/2$  | The maximum recommended coolant pressure is 150 bar (2175 psi) | For T<sub>max</sub> with diameters greater than D<sub>2</sub>, see „Technical information – Grooving“ | Refer to the Walter online catalogue for more product information: [www.walter-tools.com](http://www.walter-tools.com) | Bodies and assembly parts are included in the scope of delivery

### Assembly parts

	s [mm]	2–6
	G 1/8" threaded plug	FS2258 (SW 2)
	M6 threaded plug	FS2288 (SW 3)

### Accessories

	s [mm] h = h <sub>1</sub> [mm]	2–6 20–25
	Mounting wrench for grooving insert	FS1494

## Shank tool – Radial grooving

G2012 inch

Walter Cut



A2

– Self-clamping system

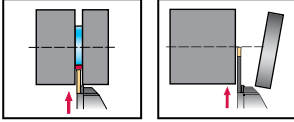

## Tool

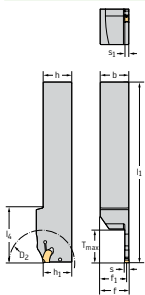

Designation	s inch	D <sub>2</sub> inch	T <sub>max</sub> inch	h = h <sub>1</sub> inch	b inch	f inch	l <sub>1</sub> inch	l <sub>4</sub> inch	s <sub>1</sub> inch	Type
G2012.12R-1.5T15SX	0,059	1,496	0,591	0,750	0,750	0,726	4,724	0,984	0,047	SX-1E1
G2012.16R-2T26SX	0,079	2,047	1,024	1,000	1,000	0,969	5,748	1,417	0,061	SX-2E2
G2012.16R-3T33SX	0,118	2,559	1,299	1,000	1,000	0,952	5,906	1,693	0,096	SX-3E3
G2012.16L-2T26SX	0,079	2,047	1,024	1,000	1,000	0,969	5,748	1,417	0,061	SX-2E2
G2012.16L-3T33SX	0,118	2,559	1,299	1,000	1,000	0,952	5,906	1,693	0,096	SX-3E3

Square shank

Dimensional drawing shows right-hand version. |  $f = f_1 + s/2$  | Refer to the Walter online catalogue for more product information: [www.walter-tools.com](http://www.walter-tools.com)

## Accessories

	s [inch] h = h <sub>1</sub> [inch]	0,059 0,75	0,079–0,118 1
	Mounting wrench for grooving insert	FS2249	FS1494

# Shank tool – Radial grooving

G2012...-P inch

**Walter Cut**



– Precision cooling

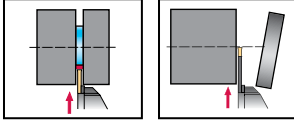

## Tool

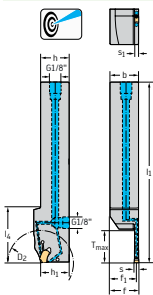

Square shank

Designation	s inch	D <sub>2</sub> inch	T <sub>max</sub> inch	h = h <sub>1</sub> inch	b inch	f <sub>1</sub> inch	l <sub>1</sub> inch	l <sub>4</sub> inch	s <sub>1</sub> inch	Type
G2012.08R-2T16SX-P	0,079	1,496	0,630	0,500	0,500	0,469	4,724	0,984	0,063	SX-2E2
G2012.10R-2T16SX-P		1,496	0,630	0,625	0,625	0,594	4,724	0,984	0,063	
G2012.12R-2T20SX-P		2,677	0,787	0,750	0,750	0,720	5,906	1,417	0,063	
G2012.10R-3T16SX-P	0,118	1,496	0,630	0,625	0,625	0,577	4,724	0,984	0,096	SX-3E3
G2012.12R-3T22SX-P		2,677	0,866	0,750	0,750	0,702	5,906	1,496	0,096	
G2012.12R-3T33SX-P		2,677	1,299	0,750	0,750	0,702	5,906	1,496	0,096	
G2012.16R-3T33SX-P	0,157	2,677	1,299	1,000	1,000	0,952	5,906	1,890	0,096	SX-4E4
G2012.12R-4T29SX-P		1,142	0,750	0,750	0,683	5,906	1,732	0,134		
G2012.16R-4T33SX-P		1,299	1,000	1,000	0,933	5,906	1,890	0,134		
G2012.16R-5T40SX-P	0,197	1,575	1,000	1,000	0,915	5,906	2,047	0,169	SX-5E5	
G2012.16R-6T40SX-P	0,236	1,575	1,000	1,000	0,896	5,906	2,047	0,209	SX-6E6	
G2012.08L-2T16SX-P	0,079	1,496	0,630	0,500	0,500	0,469	4,724	0,984	0,063	SX-2E2
G2012.10L-2T16SX-P		1,496	0,630	0,625	0,625	0,594	4,724	0,984	0,063	
G2012.12L-2T20SX-P		2,677	0,787	0,750	0,750	0,720	5,906	1,417	0,063	
G2012.10L-3T16SX-P	0,118	1,496	0,630	0,625	0,625	0,577	4,724	0,984	0,096	SX-3E3
G2012.12L-3T22SX-P		2,677	0,866	0,750	0,750	0,702	5,906	1,496	0,096	
G2012.12L-3T33SX-P		2,677	1,299	0,750	0,750	0,702	5,906	1,496	0,096	
G2012.16L-3T33SX-P	0,157	2,677	1,299	1,000	1,000	0,952	5,906	1,890	0,096	SX-4E4
G2012.12L-4T29SX-P		1,142	0,750	0,750	0,683	5,906	1,732	0,134		
G2012.16L-4T33SX-P		1,299	1,000	1,000	0,933	5,906	1,890	0,134		
G2012.16L-5T40SX-P	0,197	1,575	1,000	1,000	0,915	5,906	1,890	0,169	SX-5E5	
G2012.16L-6T40SX-P	0,236	1,575	1,000	1,000	0,896	5,906	2,047	0,209	SX-6E6	

Dimensional drawing shows right-hand version. |  $f = f_1 + s/2$  | The maximum recommended coolant pressure is 150 bar (2175 psi) | For T<sub>max</sub> with diameters greater than D<sub>2</sub>, see „Technical information – Grooving“ | Refer to the Walter online catalogue for more product information: [www.walter-tools.com](http://www.walter-tools.com) | Bodies and assembly parts are included in the scope of delivery

## Assembly parts

s [inch]	0,079–0,236
1/8" threaded plug	FS2258 (SW 2)

## Accessories

s [inch] h = h <sub>1</sub> [inch]	0,079–0,118 0,5–0,625	0,079–0,236 0,75–1
Mounting wrench for grooving insert		FS1494
Mounting wrench for grooving insert	FS2249	

# Deep parting blade

G2042...N

## Walter Cut

– Self-clamping system



A2

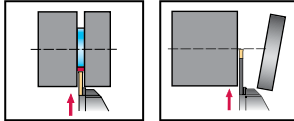

### Tool

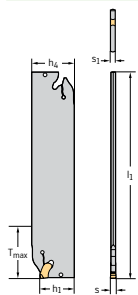

Designation	s mm	T <sub>max</sub> mm	h <sub>4</sub> mm	l <sub>1</sub> mm	h <sub>1</sub> mm	s <sub>1</sub> mm	Type
G2042.26N-2T30SX	2	30	26	110	21,1	1,6	SX-2E2
G2042.32N-2T30SX		30	32	151	24,8	1,6	
G2042.26N-3T38SX	3	38	26	110	21	2,4	SX-3E3
G2042.32N-3T50SX		50	32	151	24,7	3,4	
G2042.26N-4T40SX	4	40	26	110	20,9	3,4	SX-4E4
G2042.32N-4T50SX		50	32	151	24,5	3,4	
G2042.32N-5T60SX	5	60	32	151	24,4	4,3	SX-5E5
G2042.46N-5T80SX		80	46	251	37,4	4,3	
G2042.32N-6T60SX	6	60	32	151	24,3	5,3	SX-6E6
G2042.46N-6T80SX		80	46	251	37,3	5,3	

Refer to the Walter online catalogue for more product information: [www.walter-tools.com](http://www.walter-tools.com)

### Accessories

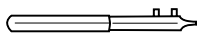
	s [mm]	2-6
	Mounting wrench for grooving insert	FS1494

A2

# Deep parting blade

 G2042...N...-P 

## Walter Cut

- Self-clamping system
- Precision cooling

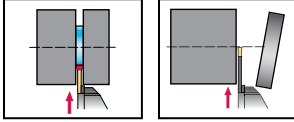

Tool	Designation	s mm	T <sub>max</sub> mm	h <sub>4</sub> mm	l <sub>1</sub> mm	h <sub>1</sub> mm	s <sub>1</sub> mm	b mm	Type
	G2042.26N-3T38SX-P	3	38	26	131	20,8	2,4	3,5	SX-3E3
	G2042.32N-3T45SX-P		45	32	151	24,5	2,4	3,5	

 Refer to the Walter online catalogue for more product information: [www.walter-tools.com](http://www.walter-tools.com) | Bodies and assembly parts are included in the scope of delivery

Assembly parts	
s [mm]	3
Coolant transfer insert	FS2282

Accessories	
s [mm]	3
Mounting wrench for grooving insert	FS1494



# Deep parting blade

G2042...N...-P

## Walter Cut

- Self-clamping system
- Precision cooling



A2

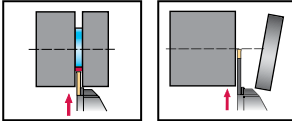

### Tool

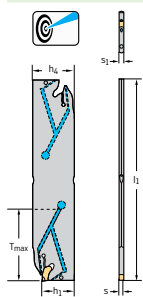

Designation	s mm	T <sub>max</sub> mm	h <sub>4</sub> mm	l <sub>1</sub> mm	h <sub>1</sub> mm	s <sub>1</sub> mm	Type
G2042.32N-4T50SX-P	4	50	32	151	24,5	3,5	SX-4E4
G2042.32N-5T60SX-P	5	60	32	151	24,4	4,3	SX-5E5
G2042.32N-6T60SX-P	6	60	32	151	24,3	5,3	SX-6E6
G2042.52N-8T100SX-P	8	100	52	251	44,3	6,8	SX-8E8
G2042.52N-10T100SX-P	10	100	52	251	44	8,8	SX-10E10

Refer to the Walter online catalogue for more product information: [www.walter-tools.com](http://www.walter-tools.com) | Bodies and assembly parts are included in the scope of delivery

### Assembly parts



s [mm]	4	5	6	8	10
Coolant transfer insert	FS2282	FS2283	FS2284	FS2285	FS2286

### Accessories

s [mm]	4-6	8-10
Mounting wrench for grooving insert	FS1494	FS2274

A2

**Reinforced parting blade**
**G2042...R/L** mm
**Walter Cut**

– Self-clamping system

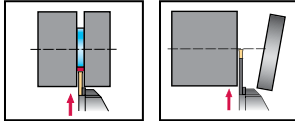
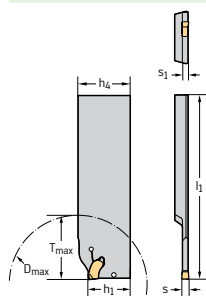
**Tool**

Designation	s mm	T <sub>max</sub> mm	D <sub>max</sub> mm	h <sub>4</sub> mm	l <sub>1</sub> mm	h <sub>1</sub> mm	s <sub>1</sub> mm	Type
G2042.26R-1.5T20SX	1,5	20	40	26	110	21	1,2	SX-1E1
G2042.32R-1.5T20SX		20	40	32	110	24,7	1,2	
G2042.26R-2T26SX	2	26	52	26	110	21	1,6	SX-2E2
G2042.32R-2T26SX		26	52	32	110	24,7	1,6	
G2042.26R-3T33SX	3	33	65	26	110	21	2,4	SX-3E3
G2042.32R-3T33SX		33	65	32	110	24,7	2,4	
G2042.32R-4T33SX	4	33	65	32	110	24,7	3,4	SX-4E4
G2042.26L-1.5T20SX	1,5	20	52	26	110	21	1,2	SX-1E1
G2042.32L-1.5T20SX		20	40	32	110	24,7	1,2	
G2042.26L-2T26SX	2	26	52	26	110	21	1,6	SX-2E2
G2042.32L-2T26SX		26	52	32	110	24,7	1,6	
G2042.26L-3T33SX	3	33	52	26	110	21	2,4	SX-3E3
G2042.32L-3T33SX		33	65	32	110	24,7	2,4	
G2042.32L-4T33SX	4	33	65	32	110	24,7	3,4	SX-4E4

 Dimensional drawing shows right-hand version. | Refer to the Walter online catalogue for more product information: [www.walter-tools.com](http://www.walter-tools.com)
**Accessories**

	s [mm]	1,5	2–4
	Mounting wrench for grooving insert	FS2249	FS1494

## Reinforced parting blade

G2042...R/L...-P 

## Walter Cut

- Self-clamping system
- Precision cooling

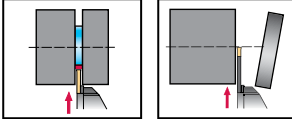

## Tool

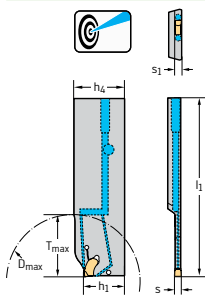

Designation	s mm	T <sub>max</sub> mm	D <sub>max</sub> mm	h <sub>4</sub> mm	l <sub>1</sub> mm	h <sub>1</sub> mm	s <sub>1</sub> mm	Type
G2042.32R-2T26SX-P	2	26	52	32	110	24,7	1,6	SX-2E2
G2042.26R-3T33SX-P	3	33	65	26	110	21	2,4	SX-3E3
G2042.32R-3T33SX-P		33	65	32	110	24,7	2,4	
G2042.32R-4T33SX-P	4	33	65	32	110	24,7	3,4	SX-4E4
G2042.32L-2T26SX-P	2	26	52	32	110	24,7	1,6	SX-2E2
G2042.26L-3T33SX-P	3	33	65	26	110	21	2,4	SX-3E3
G2042.32L-3T33SX-P		33	65	32	110	24,7	2,4	
G2042.32L-4T33SX-P	4	33	65	32	110	24,7	3,4	SX-4E4

Dimensional drawing shows right-hand version. | Refer to the Walter online catalogue for more product information: [www.walter-tools.com](http://www.walter-tools.com) | Bodies and assembly parts are included in the scope of delivery

## Accessories

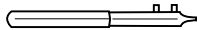
	s [mm]	2-4
	Mounting wrench for grooving insert	FS1494

## Reinforced parting blade – Contra

 G2042...R/L...C mm

## Walter Cut



– Self-clamping system

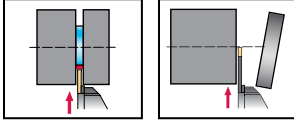

## Tool

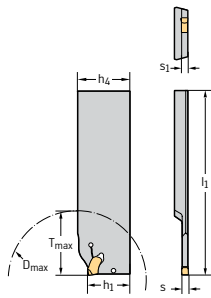

Designation	s mm	T <sub>max</sub> mm	D <sub>max</sub> mm	l <sub>1</sub> mm	s <sub>1</sub> mm	Type
G2042.32R-4T33SX-C	4	33	65	110	3,4	SX-4E4
G2042.32L-4T33SX-C	4	33	65	110	3,4	SX-4E4

 Dimensional drawing shows right-hand version. | Refer to the Walter online catalogue for more product information: [www.walter-tools.com](http://www.walter-tools.com)

## Accessories

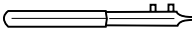
	s [mm]	
	4	FS1494

## Reinforced parting blade – Contra

G2042...R/L...C-P

mm

## Walter Cut

- Self-clamping system
- Precision cooling



A2

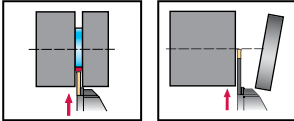

## Tool

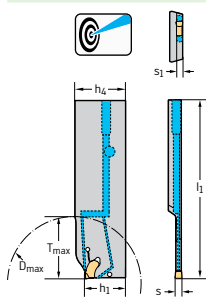

Designation	s mm	T <sub>max</sub> mm	D <sub>max</sub> mm	l <sub>1</sub> mm	s <sub>1</sub> mm	Type
G2042.26R-2T26SX-C-P	2	26	52	110	1,6	SX-2E2
G2042.32R-2T26SX-C-P		26	52	110	1,6	
G2042.26R-3T33SX-C-P	3	33	65	110	2,4	SX-3E3
G2042.32R-3T33SX-C-P		33	65	110	2,4	
G2042.32R-4T33SX-C-P	4	33	65	110	3,4	SX-4E4
G2042.26L-2T26SX-C-P	2	26	52	110	1,6	SX-2E2
G2042.32L-2T26SX-C-P		26	52	110	1,6	
G2042.26L-3T33SX-C-P	3	33	65	110	2,4	SX-3E3
G2042.32L-3T33SX-C-P		33	65	110	2,4	
G2042.32L-4T33SX-C-P	4	33	65	110	3,4	SX-4E4

Dimensional drawing shows right-hand version. | Refer to the Walter online catalogue for more product information: [www.walter-tools.com](http://www.walter-tools.com) | Bodies and assembly parts are included in the scope of delivery

## Accessories

	s [mm]	
	Mounting wrench for grooving insert	2-4 FS1494

## Shank tool – modular

 MSS-...00 

## Walter Cut



– Screw clamping

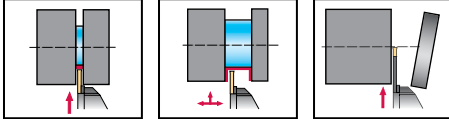

## Tool

	Designation	h = h <sub>1</sub> mm	b mm	f mm	l <sub>1</sub> mm	Module size
<p>Square shank</p>	MSS-E20R00-2020J	20	20	20,2	114,5	E20
	MSS-E25R00-2525L	25	25	25,5	145,5	E25
	MSS-E32R00-3225N	32	25	25,5	165,5	E32
<p>Square shank</p>	MSS-E20L00-2020J	20	20	20,2	114,5	E20
	MSS-E25L00-2525L	25	25	25,5	145,5	E25
	MSS-E32L00-3225N	32	25	25,5	165,5	E32

 $f = f_1 + s/2$  | Refer to the Walter online catalogue for more product information: [www.walter-tools.com](http://www.walter-tools.com) | Bodies and assembly parts are included in the scope of delivery

## Assembly parts

		E20	E25	E32
	Screw for grooving module Tightening torque	FS1053 (T15) 2 Nm	FS1054 (T20) 3 Nm	FS1055 (T25) 3 Nm
	Handle key	FS1047 (T15)	FS1048 (T20)	FS1049 (T25)

## Shank tool – modular

MSS-...00 inch

Walter Cut



A2

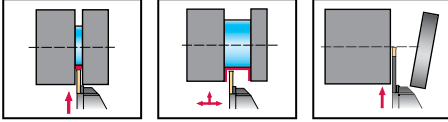

– Screw clamping

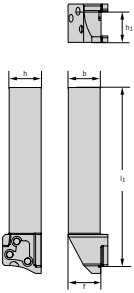
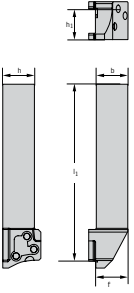

Tool		h = h <sub>1</sub> inch	b inch	f inch	h <sub>1</sub> inch	Module size
	MSS-E20R00-12-E	0,750	0,750	0,756	4,677	E20
	MSS-E25R00-16-E	1,000	1,000	1,177	5,717	E25
	MSS-E32R00-85-E	1,250	1,000	1,020	6,717	E32
Square shank						
	MSS-E20L00-12-E	0,750	0,750	0,756	4,677	E20
	MSS-E25L00-16-E	1,000	1,000	1,177	5,717	E25
	MSS-E32L00-85-E	1,250	1,000	1,020	6,717	E32
Square shank						

$f = f_1 + s/2$  | Refer to the Walter online catalogue for more product information: [www.walter-tools.com](http://www.walter-tools.com) | Bodies and assembly parts are included in the scope of delivery

## Assembly parts

		E20	E25	E32
	Screw for grooving module Tightening torque	FS1053 (T15) 1,475 lbs	FS1054 (T20) 2,213 lbs	FS1055 (T25) 2,213 lbs
	Handle key	FS1047 (T15)	FS1048 (T20)	FS1049 (T25)

## Shank tool – modular

 MSS-...90 mm

## Walter Cut



– Screw clamping

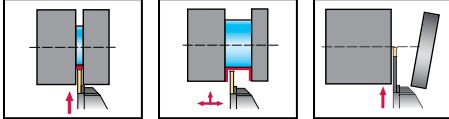

## Tool

	Designation	h = h <sub>1</sub> mm	b mm	f mm	l <sub>1</sub> mm	Module size
<p>Square shank</p>	MSS-E20R90-2020J	20	20	20	110	E20
	MSS-E25R90-2525L	25	25	25	140	E25
	MSS-E32R90-3225N	32	25	32	160	E32
<p>Square shank</p>	MSS-E20L90-2020J	20	20	20	110	E20
	MSS-E25L90-2525L	25	25	25	140	E25
	MSS-E32L90-3225N	32	25	32	160	E32

 $l_1 = l_{21} + s/2$  | Refer to the Walter online catalogue for more product information: [www.walter-tools.com](http://www.walter-tools.com) | Bodies and assembly parts are included in the scope of delivery

## Assembly parts

		E20	E25	E32
	Screw for grooving module Tightening torque	FS1053 (T15) 2 Nm	FS1054 (T20) 3 Nm	FS1055 (T25) 3 Nm
	Handle key	FS1047 (T15)	FS1048 (T20)	FS1049 (T25)



## Shank tool – modular

MSS-...90 inch

## Walter Cut



A2

– Screw clamping

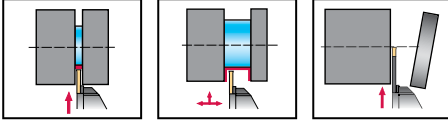

## Tool

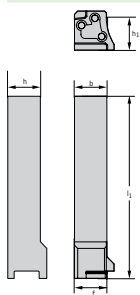

Designation	h = h <sub>1</sub> inch	b inch	f inch	l <sub>1</sub> inch	Module size
MSS-E20R90-12-E	0,750	0,750	0,787	4,500	E20
MSS-E25R90-16-E	1,000	1,000	0,984	5,500	E25
MSS-E32R90-85-E	1,250	1,000	1,260	6,500	E32

Square shank

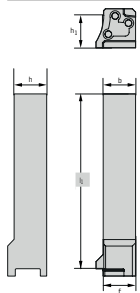



MSS-E20L90-12-E	0,750	0,750	0,787	4,500	E20
MSS-E25L90-16-E	1,000	1,000	0,984	5,500	E25
MSS-E32L90-85-E	1,250	1,000	1,260	6,500	E32

Square shank

 $l_1 = l_{21} + s/2$  | Refer to the Walter online catalogue for more product information: [www.walter-tools.com](http://www.walter-tools.com) | Bodies and assembly parts are included in the scope of delivery

## Assembly parts

		E20	E25	E32
	Screw for grooving module		FS1054 (T20) 2,213 lbs	FS1055 (T25) 2,213 lbs
	Handle key		FS1048 (T20)	FS1049 (T25)

## Grooving module – Radial grooving

G2632-E...R/L...-SX

mm

Walter Cut

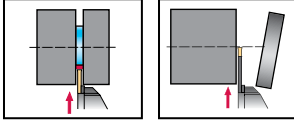

## Tool

	Designation	s mm	T <sub>max</sub> mm	D <sub>2</sub> mm	W mm	l <sub>1</sub> mm	s <sub>1</sub> mm	Module size	Type	
	G2632-E20R-2T20SX	2	20	65	4,4	42	1,6	E20	SX-2E2	
	G2632-E25R-2T20SX		20	80	5,9	48	1,6	E25		
		G2632-E20R-3T20SX	3	20	65	4,4	42	2,4	E20	SX-3E3
		G2632-E25R-3T25SX		25	90	5,9	53	2,4	E25	
		G2632-E25R-3T35SX		35	80	5,9	63	2,4	E25	
			G2632-E32R-3T45SX	4	45	90	5,9	80	2,4	E32
G2632-E20R-4T20SX			20		65	4,4	42	3,4	E20	
G2632-E25R-4T35SX			35		80	5,9	63	3,4	E25	
	G2632-E32R-4T45SX		5	45	90	5,9	80	3,4	E32	SX-5E5
	G2632-E25R-5T35SX			35	80	5,9	63	4,3	E25	
	G2632-E32R-5T45SX			45	90	5,9	80	4,3	E32	
		G2632-E25R-6T35SX	6	35	80	5,9	63	5,3	E25	SX-6E6
		G2632-E32R-6T45SX		45	90	5,9	80	5,3	E32	
		G2632-E20L-2T20SX		2	20	65	4,4	42	1,6	
G2632-E25L-2T20SX		20	80		5,9	48	1,6	E25		
		G2632-E20L-3T20SX	3	20	65	4,4	42	2,4	E20	SX-3E3
		G2632-E25L-3T25SX		25	90	5,9	53	2,4	E25	
	G2632-E25L-3T35SX	35		80	5,9	63	2,4	E25		
		G2632-E32L-3T45SX	4	45	90	5,9	80	2,4	E32	SX-4E4
		G2632-E20L-4T20SX		20	65	4,4	42	3,4	E20	
		G2632-E25L-4T35SX		35	80	5,9	63	3,4	E25	
		G2632-E32L-4T45SX	5	45	90	5,9	80	3,4	E32	SX-5E5
		G2632-E25L-5T35SX		35	80	5,9	63	4,3	E25	
		G2632-E32L-5T45SX		45	90	5,9	80	4,3	E32	
		G2632-E25L-6T35SX	6	35	80	5,9	63	5,3	E25	SX-6E6
		G2632-E32L-6T45SX		45	90	5,9	80	5,3	E32	
		G2632-E32N-8T45SX		8	45	90	5,9	80	6,8	

 Refer to the Walter online catalogue for more product information: [www.walter-tools.com](http://www.walter-tools.com)

## Accessories

s [mm]	2–6	8
Mounting wrench for grooving insert	FS1494	FS2274

## Shank tool – Radial grooving

G2016...-P 

## Walter Cut

- Screw clamping
- Precision cooling

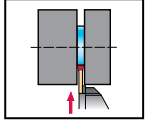

A2



## Tool

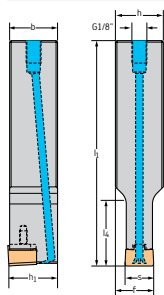

Designation	s mm	T <sub>max</sub> mm	h = h <sub>1</sub> mm	b mm	f mm	l <sub>1</sub> mm	l <sub>4</sub> mm	Type
G2016-2525N-12T40UX-P	12	41	25	25	19	150	53	UX-12E12 ..
G2016-3232N-19T40UX-P	19	41	32	32	22.5	150	53	UX-19E19 ..

Square shank

For the connection set for internal coolant supply with G1/8" thread, see „Assembly parts and accessories“ | The maximum recommended coolant pressure is 150 bar (2175 psi) | Refer to the Walter online catalogue for more product information: [www.walter-tools.com](http://www.walter-tools.com) | Bodies and assembly parts are included in the scope of delivery

## Assembly parts

	s [mm]	12	19
Clamping screw for grooving insert Tightening torque		FS2081 (T15IP) 4 Nm	FS2588 (T20IP) 5 Nm
G 1/8" threaded plug		FS2258 (SW 2)	FS2258 (SW 2)
Torx key		FS1465 (T15IP)	
Allen key			FS1464 (T20IP)

## Accessories

	s [mm]	12	19
Torque screwdriver, analogue		FS2003	FS2003
Torque screwdriver, digital		FS2248	FS2248
Interchangeable blade		FS2014 (T15IP)	FS2015 (T20IP)

# Clamping block

SBN

Walter Cut



A2

Tool	Designation	$h_4$	$h_1$ mm	$b$ mm	$l_1$ mm
 	SBN2020-26-K	26	20	20	90
	SBN2520-32-K	32	25	20	110
	SBN3229-32-K	32	32	29	120
	SBN3229-46-K	46	32	29	150
	SBN4037-46-K	46	40	37	150

Square shank

Refer to the Walter online catalogue for more product information: [www.walter-tools.com](http://www.walter-tools.com) | Bodies and assembly parts are included in the scope of delivery

Assembly parts	$h_1$ [mm]	20-25	32	40
	Clamping screw	M06X025 ISO4762 12.9 (SW 5)	M06X025 ISO4762 12.9 (SW 5)	M08X035 ISO4762 12.9 (SW 6)

## Clamping block

SBN inch

Walter Cut



A2

## Tool

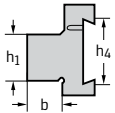

Square shank

Designation	$h_4$	$h_1$ inch	$b$ inch	$l_1$ inch
SBN12-26K-E	26	0,750	0,750	3,543
SBN12-26KS-E	26	0,750	0,750	3,543
SBN16-32-K-E	32	1,000	1,000	4,331
SBN16-32KS-E	32	1,000	1,000	4,331
SBN20-32K-E	32	1,250	1,250	4,724
SBN20-32KS-E	32	1,250	1,250	4,724

## Assembly parts

	$h_1$ [inch]	
	Clamping screw	M06X025 ISO4762 12.9 (SW 5)

# Clamping block with internal coolant

G2661...-P

## Walter Cut

- Precision cooling
- Clamping block for parting blades



### Tool

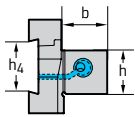
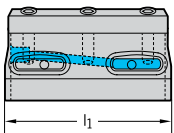

Square shank

Designation	h <sub>4</sub>	h mm	b mm	l <sub>1</sub> mm
G2661-1616N-26-P	26	16	16	95
G2661-2020N-26-P	26	20	20	95
G2661-2020N-32-P	32	20	20	95
G2661-2525N-32-P	32	25	25	95
G2661-3225N-32-P	32	32	25	95
G2661-3225N-52-P	52	32	25	140
G2661-4032N-52-P	52	40	32	140

For the connection set for internal coolant supply with G1/8" thread, see „Assembly parts and accessories“ | The maximum recommended coolant pressure is 80 bar (1160 psi) | Refer to the Walter online catalogue for more product information: [www.walter-tools.com](http://www.walter-tools.com) | Bodies and assembly parts are included in the scope of delivery

### Assembly parts

h [mm]	16-25	32	40
	Clamping wedge PK260	PK260	PK263
	Clamping screw M06X020 ISO4762 12.9 (SW 5)	M06X020 ISO4762 12.9 (SW 5)	M08X025 ISO4762 12.9 (SW 6)
	O-ring O-RING 20X2	O-RING 20X2	O-RING 27X2
	G 1/8" threaded plug FS2258 (SW 2)	FS2258 (SW 2)	FS2258 (SW 2)
	ISO 2936 key ISO2936-5 (SW 5)	ISO2936-5 (SW 5)	ISO2936-6 (SW 6)

# Clamping block with internal coolant

G2661...-P inch

## Walter Cut

- Precision cooling
- Clamping block for parting blades



A2



### Tool

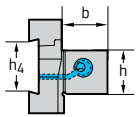
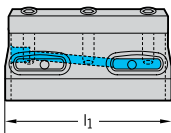





Designation	h <sub>4</sub>	h inch	b inch	l <sub>1</sub> inch
G2661.12N-26-P	26	0,750	0,750	3,74
G2661.12N-32-P	32	0,750	0,750	3,74
G2661.16N-26-P	26	1,000	1,000	3,74
G2661.16N-32-P	32	1,000	1,000	3,74
G2661.20N-32-P	32	1,250	1,250	3,74
G2661.20N-52-P	52	1,250	1,250	5,512
G2661.24N-52-P	52	1,500	1,500	5,512

Square shank

For the connection set for internal coolant supply with G1/8" thread, see „Assembly parts and accessories“ | The maximum recommended coolant pressure is 80 bar (1160 psi) | Refer to the Walter online catalogue for more product information: [www.walter-tools.com](http://www.walter-tools.com) | Bodies and assembly parts are included in the scope of delivery

### Assembly parts

h [inch]	0,75-1	1,25	1,5
 Clamping wedge	PK260	PK260	PK263
 Clamping screw	M06X020 ISO4762 12.9 (SW 5)	M06X020 ISO4762 12.9 (SW 5)	M08X025 ISO4762 12.9 (SW 6)
 O-ring	O-RING 20X2	O-RING 20X2	O-RING 27X2
 G 1/8" threaded plug	FS2258 (SW 2)	FS2258 (SW 2)	FS2258 (SW 2)
 ISO 2936 key	ISO2936-5 (SW 5)	ISO2936-5 (SW 5)	ISO2936-6 (SW 6)

## Groove turning holders – Radial grooving

 G3011-C...-P 

## Walter Cut

- Walter Capto™
- Screw clamping

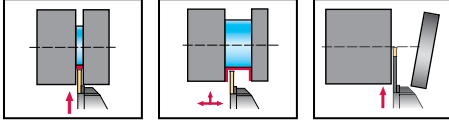

## Tool

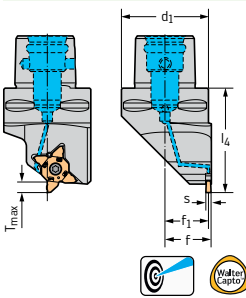

Walter Capto™ in acc. with ISO 26623

Designation	s mm	T <sub>max</sub> mm	d <sub>1</sub>	f <sub>1</sub> mm	l <sub>4</sub> mm	Type
G3011-C3R-MX22-2-P	0.5 - 3.3	6	C3	20	45	MX22-2E ..
G3011-C4R-MX22-2-P						
G3011-C5R-MX22-2-P						
G3011-C6R-MX22-2-P	4 - 5.7	6	C4	25	60	MX22-4E ..
G3011-C4R-MX22-4-P						
G3011-C5R-MX22-4-P						
G3011-C6R-MX22-4-P	0.5 - 3.3	6	C6	32	65	MX22-2E ..
G3011-C3L-MX22-2-P						
G3011-C4L-MX22-2-P						
G3011-C5L-MX22-2-P	4 - 5.7	6	C5	25	60	MX22-4E ..
G3011-C6L-MX22-2-P						
G3011-C4L-MX22-4-P						
G3011-C5L-MX22-4-P	4 - 5.7	6	C6	32	65	MX22-4E ..
G3011-C6L-MX22-4-P						

Dimensional drawing shows right-hand version. |  $F = f_1 + s/2$  | Maximum cutting depth  $T_{max}$  – see cutting inserts | The maximum recommended coolant pressure is 150 bar (2175 psi) | Refer to the Walter online catalogue for more product information: [www.walter-tools.com](http://www.walter-tools.com) | Bodies and assembly parts are included in the scope of delivery

## Assembly parts

	s [mm]	0.5 - 3.3 - 4 - 5.7
	Clamping screw for grooving insert Tightening torque	FS2571 (T20IP) 5 Nm
	Torx key	FS2572 (T20IP)

## Accessories

	s [mm]	0.5 - 3.3 - 4 - 5.7
	Torque screwdriver, analogue	FS2003
	Torque screwdriver, digital	FS2248
	Interchangeable blade	FS2015 (T20IP)



## Groove turning holders – Radial grooving

G4011-C...-P

### Walter Cut

- Walter Capto™
- Screw clamping



A2

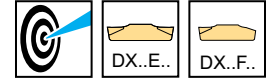
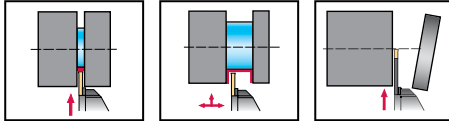

Tool		s mm	T <sub>max</sub> mm	D <sub>2</sub> mm	d <sub>1</sub>	f <sub>1</sub> mm	l <sub>4</sub> mm	s <sub>1</sub> mm	Type
	G4011-C3R-2T17DX18-P	2	17	52	C3	20	55	1,6	DX18-2E2 ..
	G4011-C4R-2T17DX18-P		17	52	C4	20	60	1,6	
	G4011-C3L-2T17DX18-P	2	17	52	C3	20	55	1,6	DX18-2E2 ..
	G4011-C4L-2T17DX18-P		17	52	C4	20	60	1,6	

Walter Capto™ in acc. with ISO 26623

Dimensional drawing shows right-hand version. |  $f = f_1 + s/2$  | If no  $D_2$  or  $D_{max}$  is specified, there is no diameter limit on the tool. | The maximum recommended coolant pressure is 150 bar (2175 psi) | Refer to the Walter online catalogue for more product information: [www.walter-tools.com](http://www.walter-tools.com) | Bodies and assembly parts are included in the scope of delivery

Assembly parts		
	s [mm]	2
	Clamping screw for grooving insert Tightening torque	FS2118 (T20IP) 5 Nm
	Allen key	FS1464 (T20IP)
Accessories		
	s [mm]	2
	Torque screwdriver, analogue	FS2003
	Torque screwdriver, digital	FS2248
	Interchangeable blade	FS2015 (T20IP)

## Groove turning holders – Radial grooving

 G1011-C...-P 

## Walter Cut

- Walter Capto™
- Screw clamping

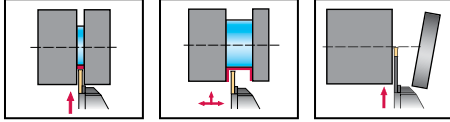

## Tool

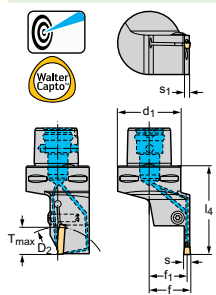

Walter Capto™ in acc. with ISO 26623

Designation	s mm	T <sub>max</sub> mm	D <sub>2</sub> mm	d <sub>1</sub>	f <sub>1</sub> mm	l <sub>4</sub> mm	s <sub>1</sub> mm	Type
G1011-C3R-3T21GX24-P	3	21	65	C3	20,5	60	2,4	GX24-2E3 .. GX24-2F3 ..
G1011-C4R-3T21GX24-P		21	65	C4	25,5	65	2,4	
G1011-C5R-3T21GX24-P		21	65	C5	30,5	70	2,4	
G1011-C4R-4T21GX24-P	4	21	65	C4	25	65	3,4	GX24-3E4 .. GX24-3F4 ..
G1011-C5R-4T21GX24-P		21		C5	30	70	3,4	
G1011-C6R-4T21GX24-P		21		C6	36	76	3,4	
G1011-C4R-5T21GX24-P	5	21		C4	24,5	65	4,2	GX24-3E5 .. GX24-3F5 ..
G1011-C5R-5T21GX24-P		21		C5	30	70	4,2	
G1011-C6R-5T21GX24-P		21		C6	36	76	4,2	
G1011-C3L-3T21GX24-P	3	21	65	C3	20,5	60	2,4	GX24-2E3 .. GX24-2F3 ..
G1011-C4L-3T21GX24-P		21	65	C4	25,5	65	2,4	
G1011-C5L-3T21GX24-P		21	65	C5	30,5	70	2,4	
G1011-C4L-4T21GX24-P	4	21	65	C4	25	65	3,4	GX24-3E4 .. GX24-3F4 ..
G1011-C5L-4T21GX24-P		21		C5	30	70	3,4	
G1011-C6L-4T21GX24-P		21		C6	36	76	3,4	
G1011-C4L-5T21GX24-P	5	21		C4	24,5	65	4,2	GX24-3E5 .. GX24-3F5 ..
G1011-C5L-5T21GX24-P		21		C5	30	70	4,2	
G1011-C6L-5T21GX24-P		21		C6	36	76	4,2	

Dimensional drawing shows right-hand version. |  $f = f_1 + s/2$  | If no  $D_2$  or  $D_{max}$  is specified, there is no diameter limit on the tool. | The maximum recommended coolant pressure is 150 bar (2175 psi) | Refer to the Walter online catalogue for more product information: [www.walter-tools.com](http://www.walter-tools.com) | Bodies and assembly parts are included in the scope of delivery

## Assembly parts

	s [mm]	3-5
	Clamping screw for grooving insert Tightening torque	FS2118 (T20IP) 5 Nm
	Allen key	FS1464 (T20IP)

## Accessories

	s [mm]	3-5
	Torque screwdriver, analogue	FS2003
	Torque screwdriver, digital	FS2248
	Interchangeable blade	FS2015 (T20IP)

## Grooving module – Radial grooving

MSS...E... 

## Walter Cut

– Screw clamping

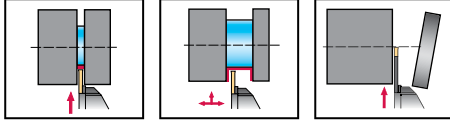

## Tool

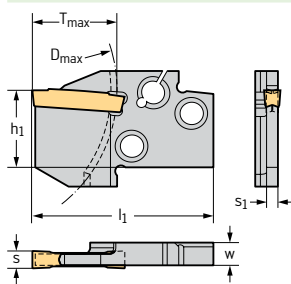

Designation	s mm	T <sub>max</sub> mm	D <sub>max</sub> mm	h <sub>1</sub> mm	W mm	l <sub>1</sub> mm	s <sub>1</sub> mm	Module size	Type	
MSS-E20R03-GX16-2	0.6 - 3	3	63	16	4,4	33	2	E20	GX16-0E ..	
MSS-E25R03-GX16-2		3	79	20	5,9	38	2	E25	GX16-1E ..	
MSS-E32R03-GX16-2		3	100	25,5		45	2	E32	GX16-2E ..	
MSS-E20R12-GX16-1	2	12	63	16	4,4	33	1,3	E20	GX16-1E2 ..	
MSS-E25R12-GX16-1		12	79	20	5,9	38	1,3	E25		
MSS-E20R12-GX16-2	3	12	63	16	4,4	33	2	E20	GX16-2E3 ..	
MSS-E20R21-GX24-2		21	63	16	4,4	42	2	E20	GX24-2E3 ..	
MSS-E25R12-GX16-2		12	79	20	5,9	38	2	E25	GX16-2E3 ..	
MSS-E25R21-GX24-2		21	79	20	5,9	47	2	E25	GX24-2E3 ..	
MSS-E32R12-GX16-2		12	100	25,5		45	2	E32	GX16-2E3 ..	
MSS-E20R12-GX16-3		4 - 5	12	63	16	4,4	33	3	E20	GX16-3E ..
MSS-E25R12-GX16-3			12	79	20	5,9	38	3	E25	
MSS-E25R21-GX24-3			21	79	20	5,9	47	3	E25	GX24-3E ..
MSS-E32R12-GX16-3			12	100	25,5		45	3	E32	GX16-3E ..
MSS-E32R21-GX24-3			21	100	25,5		54	3	E32	GX24-3E ..
MSS-E25R12-GX16-4	6	12	79	20	5,9	38	4,2	E25	GX16-4E6 ..	
MSS-E25R21-GX24-4		21	79	20	5,9	47	4,2	E25	GX24-4E6 ..	
MSS-E32R21-GX24-4		21	100	25,5		54	4,2	E32		
MSS-E25R21-GX24-5	8	21	79	20	5,9	47	5,9	E25	GX24-5R ..	
MSS-E20L03-GX16-2	0.6 - 3	3	63	16	4,4	33	2	E20	GX16-0E ..	
MSS-E25L03-GX16-2		3	79	20	5,9	38	2	E25	GX16-1E ..	
MSS-E32L03-GX16-2		3	100	25,5	5,9	45	2	E32	GX16-2E ..	
MSS-E20L12-GX16-1	2	12	63	16	4,4	33	1,3	E20	GX16-1E2 ..	
MSS-E25L12-GX16-1		12	79	20	5,9	38	1,3	E25		
MSS-E20L12-GX16-2	3	12	63	16	4,4	33	2	E20	GX16-2E3 ..	
MSS-E20L21-GX24-2		21	63	16	4,4	42	2	E20	GX24-2E3 ..	
MSS-E25L12-GX16-2		12	79	20	5,9	38	2	E25	GX16-2E3 ..	
MSS-E25L21-GX24-2		21	79	20	5,9	47	2	E25	GX24-2E3 ..	
MSS-E32L12-GX16-2		12	100	25,5	5,9	45	2	E32	GX16-2E3 ..	
MSS-E20L12-GX16-3		4 - 5	12	63	16	4,4	33	3	E20	GX16-3E ..
MSS-E25L12-GX16-3			12	79	20	5,9	38	3	E25	
MSS-E25L21-GX24-3			21	79	20	5,9	47	3	E25	GX24-3E ..
MSS-E32L12-GX16-3			12	100	25,5	5,9	45	3	E32	GX16-3E ..
MSS-E32L21-GX24-3			21	100	25,5	5,9	54	3	E32	GX24-3E ..
MSS-E25L12-GX16-4	6	12	79	20	5,9	38	4,2	E25	GX16-4E6 ..	
MSS-E25L21-GX24-4		21	79	20	5,9	47	4,2	E25	GX24-4E6 ..	
MSS-E32L21-GX24-4		21	100	25,5	5,9	54	4,2	E32		
MSS-E25L21-GX24-5	8	21	79	20	5,9	47	5,9	E25	GX24-5R ..	

Dimensional drawing shows right-hand version. | Refer to the Walter online catalogue for more product information: [www.walter-tools.com](http://www.walter-tools.com)

## Grooving module – Axial grooving

 MSS...E...A 

## Walter Cut

– Screw clamping

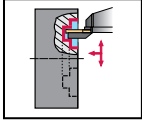

## Tool

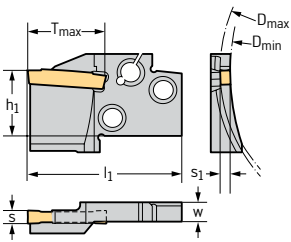

Designation	s mm	T <sub>max</sub> mm	D <sub>min</sub> mm	D <sub>max</sub> mm	h <sub>1</sub> mm	W mm	l <sub>1</sub> mm	s <sub>1</sub> mm	Module size	Type
MSS-E20R14-GX24-2A100150	3	14	100	150	16	4,4	42	2	E20	GX24-2E3 .. GX24-2F3 ..
MSS-E20R14-GX24-2A5070		14	50	70	16	4,4	42	2	E20	
MSS-E20R14-GX24-2A70100		14	70	100	16	4,4	42	2	E20	
MSS-E25R15-GX24-2A100150		15	100	150	20	5,9	47	2	E25	
MSS-E25R15-GX24-2A5070		15	50	70	20	5,9	47	2	E25	
MSS-E25R15-GX24-2A70100		15	70	100	20	5,9	47	2	E25	
MSS-E25R15-GX24-3A100150	4 - 5	15	100	150	20	5,9	47	3	E25	GX24-3E .. GX24-3F ..
MSS-E25R15-GX24-3A150300		15	150	300	20	5,9	47	3	E25	
MSS-E25R15-GX24-3A5070		15	50	70	20	5,9	47	3	E25	
MSS-E25R15-GX24-3A70100		15	70	100	20	5,9	47	3	E25	
MSS-E32R15-GX24-3A100150		15	100	150	25,5		54	3	E32	
MSS-E32R15-GX24-3A150300		15	150	300	25,5		54	3	E32	
MSS-E32R15-GX24-3A70100	15	70	100	25,5		54	3	E32		
MSS-E25R15-GX24-4A100150	6	15	100	150	20	5,9	47	4,2	E25	GX24-4E6 ..
MSS-E25R15-GX24-4A150300		15	150	300	20	5,9	47	4,2	E25	
MSS-E25R15-GX24-4A5070		15	50	70	20	5,9	47	4,2	E25	
MSS-E25R15-GX24-4A70100		15	70	100	20	5,9	47	4,2	E25	
MSS-E32R15-GX24-4A100150		15	100	150	25,5		54	4,2	E32	
MSS-E32R15-GX24-4A150300		15	150	300	25,5		54	4,2	E32	
MSS-E32R15-GX24-4A300900	15	300	900	25,5		54	4,2	E32		
MSS-E32R15-GX24-4A70100	15	70	100	25,5		54	4,2	E32		
MSS-E20L14-GX24-2A100150	3	14	100	150	16	4,4	42	2	E20	GX24-2E3 .. GX24-2F3 ..
MSS-E20L14-GX24-2A5070		14	50	70	16	4,4	42	2	E20	
MSS-E20L14-GX24-2A70100		14	70	100	16	4,4	42	2	E20	
MSS-E25L15-GX24-2A100150		15	100	150	20	5,9	47	2	E25	
MSS-E25L15-GX24-2A5070		15	50	70	20	5,9	47	2	E25	
MSS-E25L15-GX24-2A70100		15	70	100	20	5,9	47	2	E25	
MSS-E25L15-GX24-3A100150	4 - 5	15	100	150	20	5,9	47	3	E25	GX24-3E .. GX24-3F ..
MSS-E25L15-GX24-3A150300		15	150	300	20	5,9	47	3	E25	
MSS-E25L15-GX24-3A5070		15	50	70	20	5,9	47	3	E25	
MSS-E25L15-GX24-3A70100		15	70	100	20	5,9	47	3	E25	
MSS-E32L15-GX24-3A100150		15	100	150	25,5	5,9	54	3	E32	
MSS-E32L15-GX24-3A150300		15	150	300	25,5	5,9	54	3	E32	
MSS-E32L15-GX24-3A70100	15	70	100	25,5	5,9	54	3	E32		
MSS-E25L15-GX24-4A100150	6	15	100	150	20	5,9	47	4,2	E25	GX24-4E6 ..
MSS-E25L15-GX24-4A150300		15	150	300	20	5,9	47	4,2	E25	
MSS-E25L15-GX24-4A5070		15	50	70	20	5,9	47	4,2	E25	
MSS-E25L15-GX24-4A70100		15	70	100	20	5,9	47	4,2	E25	
MSS-E32L15-GX24-4A100150		15	100	150	25,5	5,9	54	4,2	E32	
MSS-E32L15-GX24-4A150300		15	150	300	25,5	5,9	54	4,2	E32	

 Dimensional drawing shows right-hand version. | Refer to the Walter online catalogue for more product information: [www.walter-tools.com](http://www.walter-tools.com)

## Tool

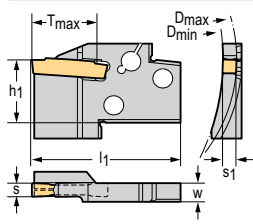

Designation	s mm	T <sub>max</sub> mm	D <sub>min</sub> mm	D <sub>max</sub> mm	h <sub>1</sub> mm	W mm	l <sub>1</sub> mm	s <sub>1</sub> mm	Module size	Type
MSS-E32L15-GX24-4A150300	6	15	150	300	25,5	5,9	54	4,2	E32	GX24-4E6 ..
MSS-E32L15-GX24-4A300900		15	300	900	25,5	5,9	54	4,2	E32	
MSS-E32L15-GX24-4A70100		15	70	100	25,5	5,9	54	4,2	E32	

Dimensional drawing shows right-hand version. | Refer to the Walter online catalogue for more product information: [www.walter-tools.com](http://www.walter-tools.com)

## Grooving module – Axial grooving

 MSS...E...C 

## Walter Cut

– Screw clamping

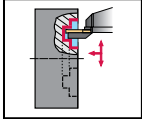

## Tool

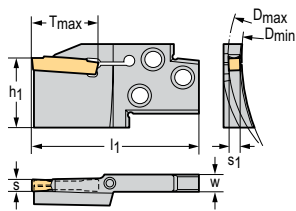

Designation	s mm	T <sub>max</sub> mm	D <sub>min</sub> mm	D <sub>max</sub> mm	h <sub>1</sub> mm	W mm	l <sub>1</sub> mm	s <sub>1</sub> mm	Module size	Type
MSS-E25R21-GX24-3C100150	4 - 5	21	100	150	20	6,2	60	3	E25	GX24-3E .. GX24-3F ..
MSS-E25R21-GX24-3C150300		21	150	300	20	6,2	60	3	E25	
MSS-E25R21-GX24-3C5070		21	50	70	20	6,2	60	3	E25	
MSS-E25R21-GX24-3C70100		21	70	100	20	6,2	60	3	E25	
MSS-E25R25-GX24-4C100150	6	25	100	150	20	6,2	60	4,2	E25	GX24-4E6 ..
MSS-E25R25-GX24-4C150300		25	150	300	20	6,2	60	4,2	E25	
MSS-E25R25-GX24-4C5070		25	50	70	20	6,2	60	4,2	E25	
MSS-E25R25-GX24-4C70100		25	70	100	20	6,2	60	4,2	E25	
MSS-E25L21-GX24-3C100150	4 - 5	21	100	150	20	6,2	60	3	E25	GX24-3E .. GX24-3F ..
MSS-E25L21-GX24-3C150300		21	150	300	20	6,2	60	3	E25	
MSS-E25L21-GX24-3C5070		21	50	70	20	6,2	60	3	E25	
MSS-E25L21-GX24-3C70100		21	70	100	20	6,2	60	3	E25	
MSS-E25L25-GX24-4C100150	6	25	100	150	20	6,2	60	4,2	E25	GX24-4E6 ..
MSS-E25L25-GX24-4C150300		25	150	300	20	6,2	60	4,2	E25	
MSS-E25L25-GX24-4C5070		25	50	70	20	6,2	60	4,2	E25	
MSS-E25L25-GX24-4C70100		25	70	100	20	6,2	60	4,2	E25	

 Dimensional drawing shows right-hand version. | Refer to the Walter online catalogue for more product information: [www.walter-tools.com](http://www.walter-tools.com) | Bodies and assembly parts are included in the scope of delivery

## Assembly parts

	s [mm]	4 - 5-6
	Clamping screw for grooving insert Tightening torque	FS1342 (T15) 2 Nm
	Handle key for grooving insert	FS1047 (T15)

## Turning toolholder – modular

C...-MSS 

## Walter Cut

- Walter Capto™
- Screw clamping



A2

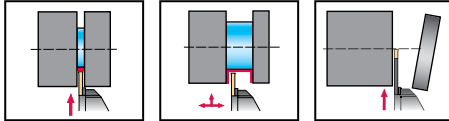

## Tool

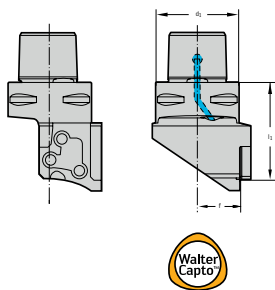

Designation	d <sub>1</sub>	f mm	l <sub>1</sub> mm	Module size
C3-MSS-E20R00	C3	16	36,5	E20
C4-MSS-E25R00	C4	20,5	47,5	E25
C5-MSS-E25R00	C5	25,5	47,5	E25
C6-MSS-E25R00	C6	31,5	53,5	E25
C6-MSS-E32R00	C6	31,5	53,5	E32

Walter Capto™ in acc. with ISO 26623

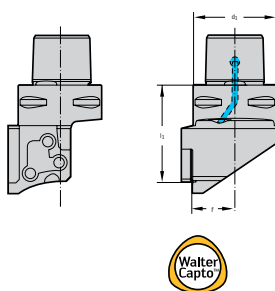





C3-MSS-E20L00	C3	16	36,5	E20
C4-MSS-E25L00	C4	20,5	47,5	E25
C5-MSS-E25L00	C5	25,5	47,5	E25
C6-MSS-E25L00	C6	31,5	53,5	E25
C6-MSS-E32L00	C6	31,5	53,5	E32

Walter Capto™ in acc. with ISO 26623

Refer to the Walter online catalogue for more product information: [www.walter-tools.com](http://www.walter-tools.com) | Bodies and assembly parts are included in the scope of delivery

## Assembly parts

	d <sub>1</sub>	E20 C3	E25 C4	E25 C5–C6	E32 C6
	Cooling nozzle	FS1477	FS1477		
	C6 cooling lubricant nozzle			FS1476	FS1476
	Screw for grooving module Tightening torque	FS1053 (T15) 2 Nm	FS1054 (T20) 3 Nm	FS1054 (T20) 3 Nm	FS1055 (T25) 3 Nm
	Handle key	FS1047 (T15)	FS1048 (T20)	FS1048 (T20)	FS1049 (T25)

## Turning toolholder – modular

C...-MSS...90

### Walter Cut

- Walter Capto™
- Screw clamping

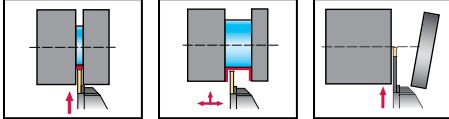

#### Tool

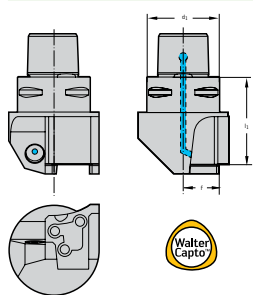

Designation	$d_1$	f mm	$h_1$ mm	Module size
-------------	-------	---------	-------------	-------------

C4-MSS-E25R90	C4	20	48,5	E25
C5-MSS-E25R90	C5	25	48,5	E25
C6-MSS-E32R90	C6	27	57	E32

Walter Capto™ in acc. with ISO 26623

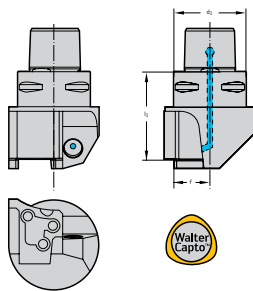

C4-MSS-E25L90	C4	20	48,5	E25
C5-MSS-E25L90	C5	25	48,5	E25
C6-MSS-E32L90	C6	27	57	E32

Walter Capto™ in acc. with ISO 26623

Refer to the Walter online catalogue for more product information: [www.walter-tools.com](http://www.walter-tools.com) | Bodies and assembly parts are included in the scope of delivery

#### Assembly parts

	$d_1$	E25 C4	E25 C5	E32 C6
	Cooling nozzle	FS1477	FS1476	FS1476
	Screw for grooving module Tightening torque	FS1054 (T20) 3 Nm	FS1054 (T20) 3 Nm	FS1055 (T25) 3 Nm
	Handle key	FS1048 (T20)	FS1048 (T20)	FS1049 (T25)



## Grooving module – Radial grooving

G2632-E...R/L...-SX 

Walter Cut



A2

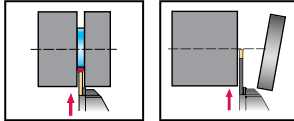

## Tool

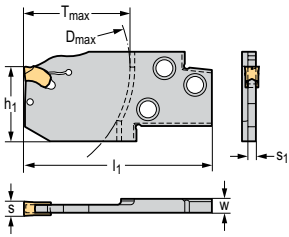
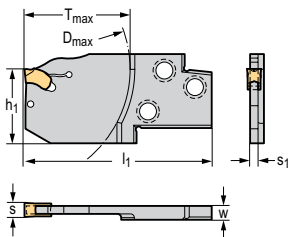
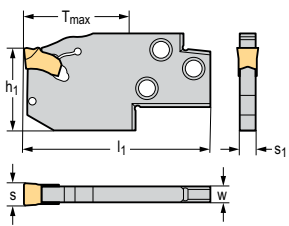
	Designation	s mm	T <sub>max</sub> mm	D <sub>2</sub> mm	W mm	l <sub>1</sub> mm	s <sub>1</sub> mm	Module size	Type		
	G2632-E20R-2T20SX	2	20	65	4,4	42	1,6	E20	SX-2E2		
	G2632-E25R-2T20SX		20	80	5,9	48	1,6	E25			
		G2632-E20R-3T20SX	3	20	65	4,4	42	2,4	E20	SX-3E3	
		G2632-E25R-3T25SX		25	90	5,9	53	2,4	E25		
		G2632-E25R-3T35SX		35	80	5,9	63	2,4	E25		
		G2632-E32R-3T45SX		45	90	5,9	80	2,4	E32		
		G2632-E20R-4T20SX	4	20	65	4,4	42	3,4	E20	SX-4E4	
		G2632-E25R-4T35SX		35	80	5,9	63	3,4	E25		
		G2632-E32R-4T45SX		45	90	5,9	80	3,4	E32		
		G2632-E25R-5T35SX	5	35	80	5,9	63	4,3	E25	SX-5E5	
		G2632-E32R-5T45SX		45	90	5,9	80	4,3	E32		
			G2632-E25R-6T35SX	6	35	80	5,9	63	5,3		E25
G2632-E32R-6T45SX					45	90	5,9	80	5,3		E32
	G2632-E20L-2T20SX	2	20	65	4,4	42	1,6	E20	SX-2E2		
	G2632-E25L-2T20SX		20	80	5,9	48	1,6	E25			
		G2632-E20L-3T20SX	3	20	65	4,4	42	2,4	E20	SX-3E3	
		G2632-E25L-3T25SX		25	90	5,9	53	2,4	E25		
		G2632-E25L-3T35SX		35	80	5,9	63	2,4	E25		
		G2632-E32L-3T45SX		45	90	5,9	80	2,4	E32		
		G2632-E20L-4T20SX	4	20	65	4,4	42	3,4	E20	SX-4E4	
		G2632-E25L-4T35SX		35	80	5,9	63	3,4	E25		
		G2632-E32L-4T45SX		45	90	5,9	80	3,4	E32		
		G2632-E25L-5T35SX	5	35	80	5,9	63	4,3	E25	SX-5E5	
		G2632-E32L-5T45SX		45	90	5,9	80	4,3	E32		
			G2632-E25L-6T35SX	6	35	80	5,9	63	5,3		E25
G2632-E32L-6T45SX					45	90	5,9	80	5,3		E32
	G2632-E32N-8T45SX	8	45	90	5,9	80	6,8	E32	SX-8E8		

Refer to the Walter online catalogue for more product information: [www.walter-tools.com](http://www.walter-tools.com)

## Accessories

s [mm]	2-6	8
Mounting wrench for grooving insert	FS1494	FS2274

## Boring bar – Internal grooving

 G3221...-P 

## Walter Cut

- Screw clamping
- Precision cooling

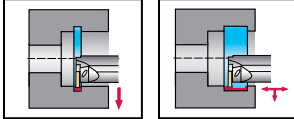

## Tool

Designation	s mm	T <sub>max</sub> mm	D <sub>min</sub> mm	d <sub>1</sub> mm	f mm	l <sub>4</sub> mm	l <sub>21</sub> mm	l <sub>1</sub> mm	Type
G3221-32SR-MX22-2-P	0.5 - 3.3	4	80	32	20,6	72	248,3	250	MX22-2E ..
G3221-32SL-MX22-2-P	0.5 - 3.3	4	80	32	20,6	72	248,3	250	MX22-2E ..

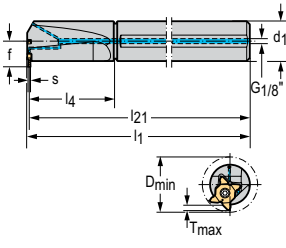

Cylindrical shank with flat

Dimensional drawing shows right-hand version. | For the connection set for internal coolant supply with G1/8" thread, see „Assembly parts and accessories“ | The maximum recommended coolant pressure is 80 bar (1160 psi) | Refer to the Walter online catalogue for more product information: [www.walter-tools.com](http://www.walter-tools.com) | Bodies and assembly parts are included in the scope of delivery

## Assembly parts

	s [mm]	0.5 - 3.3
	Clamping screw for grooving insert Tightening torque	FS2571 (T20IP) 5 Nm
	Threaded plug	M03X003 ISO 4026 (SW 1,5)
	O-ring	O-RING 27X2
	Torx key	FS2572 (T20IP)

## Accessories

	s [mm]	0.5 - 3.3
	Torque screwdriver, analogue	FS2003
	Interchangeable blade	FS2015 (T20IP)
	Torque screwdriver, digital	FS2248

## Boring bar – Internal grooving

G4221...-P

### Walter Cut

- Screw clamping
- Precision cooling

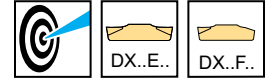
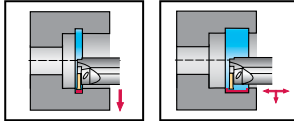

### Tool

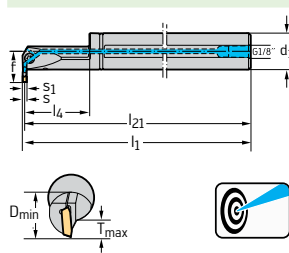

Designation	s mm	T <sub>max</sub> mm	D <sub>min</sub> mm	d <sub>1</sub> mm	f mm	l <sub>4</sub> mm	l <sub>21</sub> mm	s <sub>1</sub> mm	Type
G4221-25RR-2T08-DX18-P	2	8	25	25	21,1	46,2	199,2	1,6	DX18-2E2 ..
G4221-25RR-3T08-DX18-P	3	8	25	25	21,1	46,3	198,8	2,5	DX18-3E3 ..
G4221-32SR-3T10-DX18-P									DX18-3F3 ..
G4221-32SR-4T10-DX18-P	4	10	32	32	26,6	59,3	248,8	3,4	DX18-4E4 .. DX18-4F4 ..
G4221-25RL-2T08-DX18-P	2	8	25	25	21,1	46,2	199,2	1,6	DX18-2E2 ..
G4221-25RL-3T08-DX18-P	3	8	25	25	21,1	46,3	198,8	2,5	DX18-3E3 ..
G4221-32SL-3T10-DX18-P									DX18-3F3 ..
G4221-32SL-4T10-DX18-P	4	10	32	32	26,6	59,3	248,8	3,4	DX18-4E4 .. DX18-4F4 ..

Cylindrical shank with flat

Dimensional drawing shows right-hand version. |  $l_1 = l_{21} + s/2$  | The maximum recommended coolant pressure is 80 bar (1160 psi) | For the connection set for internal coolant supply with G1/8" thread, see „Assembly parts and accessories“ | Refer to the Walter online catalogue for more product information: [www.walter-tools.com](http://www.walter-tools.com) | Bodies and assembly parts are included in the scope of delivery

### Assembly parts

	D <sub>min</sub> [mm]	25	32
	Clamping screw for grooving insert Tightening torque	FS1495 (T20IP) 5 Nm	FS2089 (T25IP) 6 Nm
	Threaded plug	M03X003 ISO 4026 (SW 1,5)	M03X003 ISO 4026 (SW 1,5)
	O-ring	O-RING 20X2	O-RING 27X2
	Screwdriver	FS1486 (T20IP)	FS1487 (T25IP)

### Accessories

	D <sub>min</sub> [mm]	25	32
	Torque screwdriver, analogue	FS2003	FS2003
	Interchangeable blade	FS2015 (T20IP)	FS2016 (T25IP)
	Torque screwdriver, digital	FS2248	FS2248

# Boring bar – Internal grooving

**G4221...-P**    **inch**

## Walter Cut

- Screw clamping
- Precision cooling

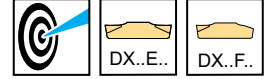
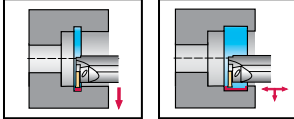

### Tool

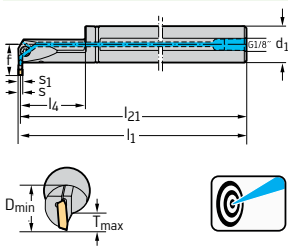

Designation	s inch	T <sub>max</sub> inch	D <sub>min</sub> inch	d <sub>1</sub> inch	f inch	l <sub>4</sub> inch	l <sub>21</sub> inch	s <sub>1</sub> inch	Type
G4221.16RR-2T08-DX18-P	0,079	0,315	1,000	1,000	0,839	1,821	7,843	0,063	DX18-2E2 ..
G4221.16RR-3T08-DX18-P	0,118	0,315	1,000	1,000	0,839	1,821	7,825	0,098	DX18-3E3 ..
G4221.20SR-3T10-DX18-P									DX18-3F3 ..
G4221.20SR-4T10-DX18-P	0,157	0,394	1,250	1,250	1,043	2,335	9,776	0,134	DX18-4E4 .. DX18-4F4 ..

Cylindrical shank with flat

$l_1 = l_{21} + s/2$  | The maximum recommended coolant pressure is 80 bar (1160 psi) | For the connection set for internal coolant supply with G1/8" thread, see „Assembly parts and accessories“ | Refer to the Walter online catalogue for more product information: [www.walter-tools.com](http://www.walter-tools.com) | Bodies and assembly parts are included in the scope of delivery

### Assembly parts

	D <sub>min</sub> [inch]	1	1,25
	Clamping screw for grooving insert Tightening torque	FS1495 (T20IP) 3,688 lbs	FS2089 (T25IP) 4,425 lbs
	Threaded plug	M03X003 ISO 4026 (SW 1,5)	M03X003 ISO 4026 (SW 1,5)
	O-ring	O-RING 20X2	O-RING 27X2
	Screwdriver	FS1486 (T20IP)	FS1487 (T25IP)

### Accessories

	D <sub>min</sub> [inch]	1	1,25
	Torque screwdriver, analogue	FS2004	FS2004
	Interchangeable blade	FS2015 (T20IP)	FS2016 (T25IP)
	Torque screwdriver, digital	FS2248	FS2248

## Boring bar – Internal grooving

I12

### Walter Cut



A2

– Screw clamping

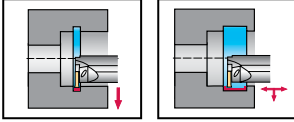

### Tool

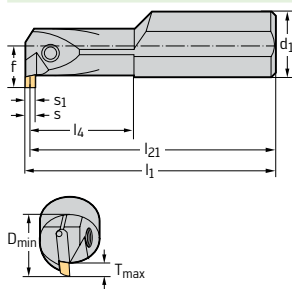

Designation	s mm	T <sub>max</sub> mm	D <sub>min</sub> mm	d <sub>1</sub> mm	f mm	l <sub>4</sub> mm	l <sub>21</sub> mm	l <sub>1</sub> mm	s <sub>1</sub> mm	Type
I12R90-2.5D-GX09	2 - 2.5	3	16	16	11	30	149,5	151	1,3	GX09-1E1 ..
I12L90-2.5D-GX09	2 - 2.5	3	16	16	11	30	149,5	151	1,3	GX09-1E1 ..

Cylindrical shank

Dimensional drawing shows right-hand version. | Refer to the Walter online catalogue for more product information: [www.walter-tools.com](http://www.walter-tools.com) | Bodies and assembly parts are included in the scope of delivery

### Assembly parts

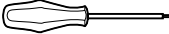
	s [mm] D <sub>min</sub> [mm]	
	2 - 2.5 16	FS2139 (T20IP) 5 Nm
		FS1486 (T20IP)

# Boring bar – Internal grooving

**G1221...-P** mm

## Walter Cut

- Screw clamping
- Precision cooling

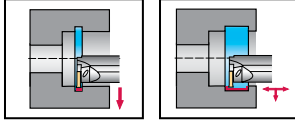

### Tool

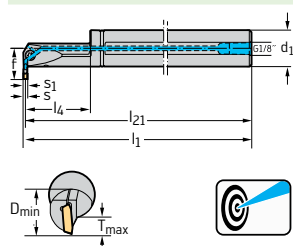

Cylindrical shank with flat

Designation	s mm	T <sub>max</sub> mm	D <sub>min</sub> mm	d <sub>1</sub> mm	f mm	l <sub>4</sub> mm	l <sub>21</sub> mm	l <sub>1</sub> mm	s <sub>1</sub> mm	Type
G1221-16QR-2T04-GX09-P	2 - 2.5	4	16	16	12,6	29,3	179,3	180,3	1,4	GX09-1E1 ..
G1221-20QR-2T06-GX09-P		6	20	20	16,6	36,3	179,3	180,3	1,4	
G1221-20QR-3T06-GX09-P	2.5 - 3	6	20	20	16,6	35,9	179	180,45	2,1	GX09-2E3 ..
G1221-40TR-3T12-GX24-P	3	12	40	40	32,6	72	299	300,45	2,1	GX24-2E3 .. GX24-2F3 ..
G1221-40TR-4T12-GX24-P	4	12	40	40	32,6	71,5	298,5	300,45	3,1	GX24-3E .. GX24-3F ..
G1221-40TR-5T12-GX24-P	5 - 6	12	40	40	32,6	71,1	298,1	300,6	3,8	
G1221-16QL-2T04-GX09-P	2 - 2.5	4	16	16	12,6	29,3	179,3	180,3	1,4	GX09-1E1 ..
G1221-20QL-2T06-GX09-P		6	20	20	16,6	36,3	179,3	180,3	1,4	
G1221-20QL-3T06-GX09-P	2.5 - 3	6	20	20	16,6	35,9	179	180,45	2,1	GX09-2E3 ..
G1221-40TL-3T12-GX24-P	3	12	40	40	32,6	72	299	300,45	2,1	GX24-2E3 .. GX24-2F3 ..
G1221-40TL-4T12-GX24-P	4	12	40	40	32,6	71,5	298,5	300,45	3,1	GX24-3E .. GX24-3F ..
G1221-40TL-5T12-GX24-P	5 - 6	12	40	40	32,6	71,1	298,1	300,6	3,8	

Dimensional drawing shows right-hand version. |  $l_1 = l_{21} + s/2$  | For the connection set for internal coolant supply with G1/8" thread, see „Assembly parts and accessories“ | The maximum recommended coolant pressure is 80 bar (1160 psi) | Refer to the Walter online catalogue for more product information: [www.walter-tools.com](http://www.walter-tools.com) | Bodies and assembly parts are included in the scope of delivery

### Assembly parts

	s [mm] D <sub>min</sub> [mm]	3-5 - 6 40	2 - 2.5 16	2 - 2.5-2.5 - 3 20
	Clamping screw for grooving insert Tightening torque	FS2089 (T25IP) 6 Nm	FS1453 (T15IP) 3,5 Nm	FS2081 (T15IP) 4 Nm
	Threaded plug	M02X002 ISO 4026 (SW 0,9)	M02X002 ISO 4026 (SW 0,9)	M03X003 ISO 4026 (SW 1,5)
	O-ring	O-RING 34X2	O-RING 11X2	O-RING 15X2
	Screwdriver	FS1487 (T25IP)	FS1485 (T15IP)	FS1485 (T15IP)

### Accessories

	s [mm] D <sub>min</sub> [mm]	3-5 - 6 40	2 - 2.5-2.5 - 3 16-20
	Torque screwdriver, analogue	FS2003	FS2003
	Interchangeable blade	FS2016 (T25IP)	FS2014 (T15IP)
	Torque screwdriver, digital	FS2248	FS2248

## Boring bar – Internal grooving

G1221...-P inch

## Walter Cut

- Screw clamping
- Precision cooling

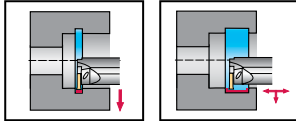

## Tool

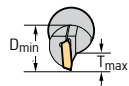
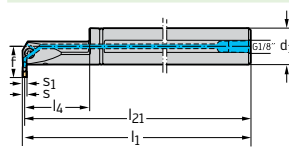

Cylindrical shank with flat

Designation	s inch	T <sub>max</sub> inch	D <sub>min</sub> inch	d <sub>1</sub> inch	f inch	l <sub>4</sub> inch	l <sub>21</sub> inch	l <sub>1</sub> inch	s <sub>1</sub> inch	Type
G1221.10QR-2T04-GX09-P	0,079 - 0,098	0,157	0,625	0,625	0,492	1,154	7,059	7,098	0,055	GX09-1E1 ..
G1221.12QR-2T06-GX09-P		0,236	0,750	0,750	0,634	1,429	7,059	7,098	0,055	
G1221.12QR-3T06-GX09-P	0,098 - 0,118	0,236	0,750	0,750	0,634	1,413	7,045	7,104	0,083	GX09-2E3 ..
G1221.24TR-4T12-GX24-P	0,157	0,472	1,500	1,500	1,244	2,813	11,750	11,829	0,122	GX24-3E .. GX24-3F ..
G1221.10QL-2T04-GX09-P	0,079 - 0,098	0,157	0,625	0,625	0,492	1,154	7,059	7,098	0,055	GX09-1E1 ..
G1221.12QL-2T06-GX09-P		0,236	0,750	0,750	0,634	1,429	7,059	7,098	0,055	
G1221.12QL-3T06-GX09-P	0,098 - 0,118	0,236	0,750	0,750	0,634	1,413	7,045	7,104	0,083	GX09-2E3 ..
G1221.24TL-4T12-GX24-P	0,157	0,472	1,500	1,500	1,244	2,813	11,750	11,829	0,122	GX24-3E .. GX24-3F ..

Dimensional drawing shows right-hand version. |  $l_1 = l_{21} + s/2$  | For the connection set for internal coolant supply with G1/8" thread, see „Assembly parts and accessories“ | The maximum recommended coolant pressure is 80 bar (1160 psi) | Refer to the Walter online catalogue for more product information: [www.walter-tools.com](http://www.walter-tools.com) | Bodies and assembly parts are included in the scope of delivery

## Assembly parts

	s [inch] D <sub>min</sub> [inch]	0,079 - 0,098 0,625	0,079 - 0,098 - 0,098 - 0,118 0,75	0,157 1,5
	Clamping screw for grooving insert Tightening torque	FS1453 (T15IP) 2,581 lbs	FS2081 (T15IP) 2,95 lbs	FS2089 (T25IP) 4,425 lbs
	Threaded plug	M02X002 ISO 4026 (SW 0,9)	M03X003 ISO 4026 (SW 1,5)	M02X002 ISO 4026 (SW 0,9)
	O-ring	O-RING 11X2	O-RING 15X2	O-RING 34X2
	Screwdriver	FS1485 (T15IP)	FS1485 (T15IP)	FS1487 (T25IP)

## Accessories

	s [inch] D <sub>min</sub> [inch]	0,079 - 0,098 - 0,098 - 0,118 0,625 - 0,75	0,157 1,5
	Torque screwdriver, analogue	FS2004	FS2004
	Interchangeable blade	FS2014 (T15IP)	FS2016 (T25IP)
	Torque screwdriver, digital	FS2248	FS2248

## Boring bar – modular

 MSS...I...90-1.5 mm

## Walter Cut



– Screw clamping

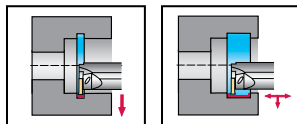

## Tool

	Designation	d <sub>1</sub> mm	l <sub>16</sub> mm	l <sub>5</sub> mm	l <sub>1</sub> mm	Module size
 Cylindrical shank	MSS-I16R90-1,5D-N	20	20,2	50	81,7	I16
	MSS-I20R90-1,5D-N	20	26,2	50	86,7	I20
	MSS-I25R90-1,5D-N	25	36,2	56	101,7	I25
	MSS-I32R90-1,5D-N	32	41,1	60	118,6	I32
	MSS-I40R90-1,5D-N	40	54,1	70	141,6	I40
 Cylindrical shank	MSS-I16L90-1,5D-N	20	20,2	50	81,7	I16
	MSS-I20L90-1,5D-N	20	26,2	50	86,7	I20
	MSS-I25L90-1,5D-N	25	36,2	56	101,7	I25
	MSS-I32L90-1,5D-N	32	41,1	60	118,6	I32
	MSS-I40L90-1,5D-N	40	54,1	70	141,6	I40

 Refer to the Walter online catalogue for more product information: [www.walter-tools.com](http://www.walter-tools.com) | Bodies and assembly parts are included in the scope of delivery

## Assembly parts

		I16	I20	I25	I32	I40
	Screw for grooving module Tightening torque	FS1051 (T8) 2 Nm	FS1056 (T10) 2 Nm	FS1052 (T15) 2 Nm	FS1057 (T20) 3 Nm	FS1054 (T20) 3 Nm
	Handle key	FS257 (T8)	FS1050 (T10)	FS1047 (T15)	FS1048 (T20)	FS1048 (T20)



## Boring bar – modular

MSS...I...90-2.5 mm

## Walter Cut



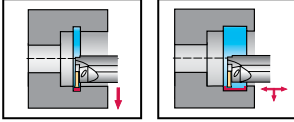

A2

– Screw clamping

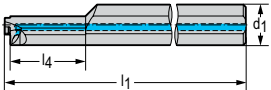
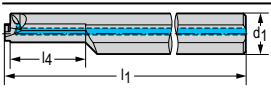

Tool	Designation	d <sub>1</sub> mm	l <sub>4</sub> mm	l <sub>1</sub> mm	Module size
 Cylindrical shank	MSS-I16R90-2,5D-N	20	36,2	179,7	I16
	MSS-I20R90-2,5D-N	25	46,2	199,7	I20
	MSS-I25R90-2,5D-N	32	59,2	249,7	I25
	MSS-I32R90-2,5D-N	40	74,1	299,6	I32
	MSS-I40R90-2,5D-N	50	94,1	349,6	I40
 Cylindrical shank	MSS-I16L90-2,5D-N	20	36,2	179,7	I16
	MSS-I20L90-2,5D-N	25	46,2	199,7	I20
	MSS-I25L90-2,5D-N	32	59,2	249,7	I25
	MSS-I32L90-2,5D-N	40	74,1	299,6	I32
	MSS-I40L90-2,5D-N	50	94,1	349,6	I40

Refer to the Walter online catalogue for more product information: [www.walter-tools.com](http://www.walter-tools.com) | Bodies and assembly parts are included in the scope of delivery

Assembly parts		I16	I20	I25	I32	I40
	Screw for grooving module Tightening torque	FS1051 (T8) 2 Nm	FS1056 (T10) 2 Nm	FS1052 (T15) 2 Nm	FS1057 (T20) 3 Nm	FS1054 (T20) 3 Nm
	Handle key	FS257 (T8)	FS1050 (T10)	FS1047 (T15)	FS1048 (T20)	FS1048 (T20)

## Boring bar – modular

 MSS...I...90-1.5 inch

## Walter Cut



– Screw clamping

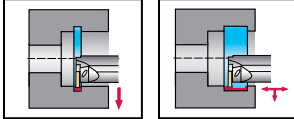

## Tool

	Designation	d <sub>1</sub> inch	l <sub>16</sub> inch	l <sub>5</sub> inch	l <sub>1</sub> inch	Module size
 Cylindrical shank	MSS-I16R90-1,5D-E	0,750	0,795	1,969	3,217	I16
	MSS-I20R90-1,5D-E	0,750	1,031	1,969	3,413	I20
	MSS-I25R90-1,5D-E	1,000	1,425	2,205	4,004	I25
	MSS-I32R90-1,5D-E	1,250	1,618	2,362	4,669	I32
	MSS-I40R90-1,5D-E	1,500	2,130	2,756	5,575	I40
 Cylindrical shank	MSS-I16L90-1,5D-E	0,750	0,795	1,969	3,217	I16
	MSS-I20L90-1,5D-E	0,750	1,031	1,969	3,413	I20
	MSS-I25L90-1,5D-E	1,000	1,425	2,205	4,004	I25
	MSS-I32L90-1,5D-E	1,250	1,618	2,362	4,669	I32
	MSS-I40L90-1,5D-E	1,500	2,130	2,756	5,575	I40

 Refer to the Walter online catalogue for more product information: [www.walter-tools.com](http://www.walter-tools.com) | Bodies and assembly parts are included in the scope of delivery

## Assembly parts

		I16	I20	I25	I32	I40
	Screw for grooving module Tightening torque	FS1051 (T8) 1,475 lbs	FS1056 (T10) 1,475 lbs	FS1052 (T15) 1,475 lbs	FS1057 (T20) 2,213 lbs	FS1054 (T20) 2,213 lbs
	Handle key	FS257 (T8)	FS1050 (T10)	FS1047 (T15)	FS1048 (T20)	FS1048 (T20)

## Boring bar – modular

MSS...l...90-2.5 inch

## Walter Cut



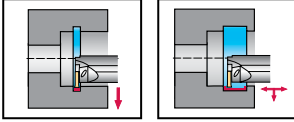

A2

– Screw clamping

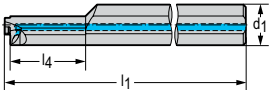
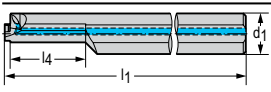

Tool	Designation	d <sub>1</sub> inch	l <sub>4</sub> inch	l <sub>1</sub> inch	Module size
 Cylindrical shank	MSS-I16R90-2,5D-E	0,750	1,425	7,075	I16
	MSS-I20R90-2,5D-E	1,000	1,819	7,862	I20
	MSS-I25R90-2,5D-E	1,250	2,331	9,831	I25
	MSS-I32R90-2,5D-E	1,500	2,917	11,795	I32
	MSS-I40R90-2,5D-E	2,000	3,705	13,764	I40
 Cylindrical shank	MSS-I16L90-2,5D-E	0,750	1,425	7,075	I16
	MSS-I20L90-2,5D-E	1,000	1,819	7,862	I20
	MSS-I25L90-2,5D-E	1,250	2,331	9,831	I25
	MSS-I32L90-2,5D-E	1,500	2,917	11,795	I32
	MSS-I40L90-2,5D-E	2,000	3,705	13,764	I40

Refer to the Walter online catalogue for more product information: [www.walter-tools.com](http://www.walter-tools.com) | Bodies and assembly parts are included in the scope of delivery

Assembly parts		I16	I20	I25	I32	I40
	Screw for grooving module Tightening torque	FS1051 (T8) 1,475 lbs	FS1056 (T10) 1,475 lbs	FS1052 (T15) 1,475 lbs	FS1057 (T20) 2,213 lbs	FS1054 (T20) 2,213 lbs
	Handle key	FS257 (T8)	FS1050 (T10)	FS1047 (T15)	FS1048 (T20)	FS1048 (T20)

## Grooving module – Internal grooving

 MSS...I... 

## Walter Cut

– Screw clamping

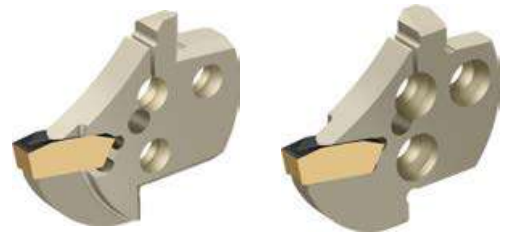
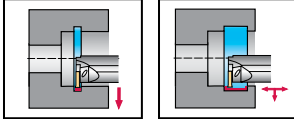

## Tool

Designation	s mm	T <sub>max</sub> mm	D <sub>min</sub> mm	h <sub>1</sub> mm	W mm	l <sub>1</sub> mm	s <sub>1</sub> mm	Module size	Type	
MSS-I32R03-GX16-2	0.6 - 3	3	40	12,3	5,9	38	2	I32	GX16-0E .. GX16-1E .. GX16-2E ..	
MSS-I40R03-GX16-2		3	50	15,5	5,9	47	2	I40		
MSS-I16R02-GX09-1	2	2	20	6,3	3,8	19	1,3	I16		GX09-1E ..
MSS-I16R04-GX09-1		4	20	6,3	3,8	19	1,3	I16	GX09-1E1 ..	
MSS-I20R02-GX09-1		2	25	7,6	3,8	23	1,3	I20	GX09-1E ..	
MSS-I20R05-GX09-1		5	25	7,6	3,8	23	1,3	I20	GX09-1E1 ..	
MSS-I25R02-GX09-1		2	32	9,8	3,8	30	1,3	I25	GX09-1E ..	
MSS-I25R06-GX09-1		6	32	9,8	3,8	30	1,3	I25	GX09-1E1 ..	
MSS-I32R09-GX16-1		9	40	12,3	5,9	38	1,3	I32	GX16-1E2 ..	
MSS-I40R10-GX16-1			10	50	15,5	5,9	47	1,3		I40
MSS-I16R04-GX09-2		3	4	20	6,3	3,8	19	2	I16	GX09-2E3 ..
MSS-I20R05-GX09-2			5	25	7,6	3,8	23	2	I20	
MSS-I25R06-GX09-2	6		32	9,8	3,8	30	2	I25		
MSS-I32R09-GX16-2	9		40	12,3	5,9	38	2	I32		
MSS-I40R10-GX16-2	10	50	15,5	5,9	47	2	I40	GX16-2E3 ..		
MSS-I32R09-GX16-3		4 - 5	9	40	12,3	5,9	38		3	I32
MSS-I40R10-GX16-3	10		50	15,5	5,9	47	3	I40		
MSS-I32R09-GX16-4	6	9	40	12,3	5,9	38	4,2	I32	GX16-4E6 ..	
MSS-I40R10-GX16-4		10	50	15,5	5,9	47	4,2	I40		
MSS-I32L03-GX16-2	0.6 - 3	3	40	12,3	5,9	38	2	I32	GX16-0E .. GX16-1E .. GX16-2E ..	
MSS-I40L03-GX16-2		3	50	15,5	5,9	47	2	I40		
MSS-I16L02-GX09-1	2	2	20	6,3	3,8	19	1,3	I16		GX09-1E ..
MSS-I16L04-GX09-1		4	20	6,3	3,8	19	1,3	I16	GX09-1E1 ..	
MSS-I20L02-GX09-1		2	25	7,6	3,8	23	1,3	I20	GX09-1E ..	
MSS-I20L05-GX09-1		5	25	7,6	3,8	23	1,3	I20	GX09-1E1 ..	
MSS-I25L02-GX09-1		2	32	9,8	3,8	30	1,3	I25	GX09-1E ..	
MSS-I25L06-GX09-1		6	32	9,8	3,8	30	1,3	I25	GX09-1E1 ..	
MSS-I32L09-GX16-1		9	40	12,3	5,9	38	1,3	I32	GX16-1E2 ..	
MSS-I40L10-GX16-1			10	50	15,5	5,9	47	1,3		I40
MSS-I16L04-GX09-2		3	4	20	6,3	3,8	19	2	I16	GX09-2E3 ..
MSS-I20L05-GX09-2			5	25	7,6	3,8	23	2	I20	
MSS-I25L06-GX09-2	6		32	9,8	3,8	30	2	I25		
MSS-I32L09-GX16-2	9		40	12,3	5,9	38	2	I32		
MSS-I40L10-GX16-2	10	50	15,5	5,9	47	2	I40	GX16-2E3 ..		
MSS-I32L09-GX16-3		4 - 5	9	40	12,3	5,9	38		3	I32
MSS-I40L10-GX16-3	10		50	15,5	5,9	47	3	I40		
MSS-I32L09-GX16-4	6	9	40	12,3	5,9	38	4,2	I32	GX16-4E6 ..	
MSS-I40L10-GX16-4		10	50	15,5	5,9	47	4,2	I40		

 Refer to the Walter online catalogue for more product information: [www.walter-tools.com](http://www.walter-tools.com)

Tool		Designation	s mm	T <sub>max</sub> mm	D <sub>min</sub> mm	h <sub>1</sub> mm	W mm	l <sub>1</sub> mm	s <sub>1</sub> mm	Module size	Type
		MSS-I40N19-GX24-3	4 - 5	19	60	15,5	6,2	55	3	I40	GX24-3E .. GX24-3F ..
		MSS-I40N19-GX24-4	6	19	60	15,5	6,2	55	4,2	I40	GX24-4E6 ..

Refer to the Walter online catalogue for more product information: [www.walter-tools.com](http://www.walter-tools.com)

# Boring bar for exchangeable head

## W3270-A mm



- Screw clamping
- A = Steel version with internal cooling

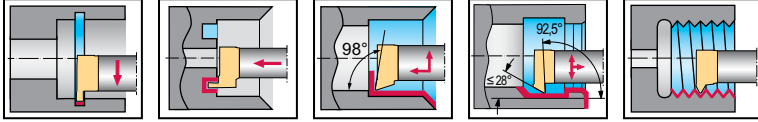

### Tool

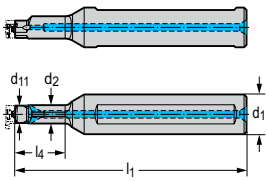

Designation	d <sub>11</sub> mm	d <sub>2</sub> mm	d <sub>1</sub> mm	l <sub>1</sub> mm	l <sub>4</sub> mm
★ W3270-A12-21-WE05	5	6	12	76,3	17,3
★ W3270-A16-12-WE05	5	6	16	76,3	8,3
★ W3270-A16-16-WE07	7	9	16	93,1	12,1
★ W3270-A16-20-WE09	9	11	16	94,7	14,7
★ W3270-A16-24-WE07	7	9	16	93,1	20,1
★ W3270-A16-30-WE09	9	11	16	94,8	24,2

Parallel shank with clamping surface

Bodies and assembly parts are included in the scope of delivery

### Assembly parts

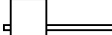
	d <sub>11</sub> [mm]	5	7	9
 Clamping screw Tightening torque		FS2676 (T7IP) 0,8 Nm	FS2692 (T9IP) 2,1 Nm	FS2679 (T15IP) 4,5 Nm
 Torx key		FS1490 (T7IP)	FS1466 (T9IP)	FS1465 (T15IP)

## Boring bar for exchangeable head

W3270-E 

A2

- Screw clamping
- E = Solid carbide version with internal cooling

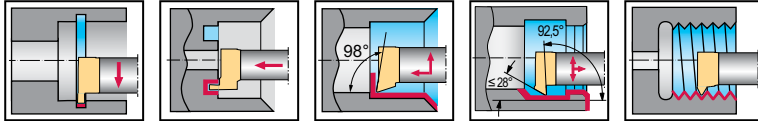

## Tool

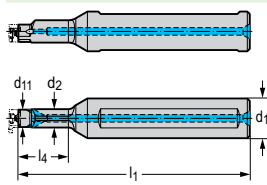

Parallel shank with clamping surface

Designation	d <sub>11</sub> mm	d <sub>2</sub> mm	d <sub>1</sub> mm	l <sub>1</sub> mm	l <sub>4</sub> mm
★ W3270-E12-20-WE09	9	11	12	75	14,8
★ W3270-E12-21-WE05	5	6	12	76,3	17,3
★ W3270-E12-24-WE07	7	9	12	88,1	20,1
★ W3270-E12-30-WE05	5	6	12	86,3	26,3
★ W3270-E12-32-WE07	7	9	12	96,1	28,1
★ W3270-E12-34-WE09	9	11	12	94,8	28,8
★ W3270-E12-42-WE05	5	6	12	96,3	38,3
★ W3270-E12-45-WE09	9	11	12	104,8	39,8
★ W3270-E12-48-WE07	7	9	12	111,1	44,1
★ W3270-E12-64-WE07	7	9	12	126,1	60,1
★ W3270-E12-64-WE09	9	11	12	124,8	58,8
★ W3270-E16-34-WE09	9	11	16	94,8	28,8
★ W3270-E16-45-WE09	9	11	16	104,8	39,8
★ W3270-E16-64-WE09	9	11	16	124,8	58,8

Bodies and assembly parts are included in the scope of delivery

## Assembly parts

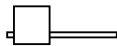
	d <sub>11</sub> [mm]	5	7	9
	Clamping screw Tightening torque	FS2676 (T7IP) 0,8 Nm	FS2692 (T9IP) 2,1 Nm	FS2679 (T15IP) 4,5 Nm
	Torx key	FS1490 (T7IP)	FS1466 (T9IP)	FS1465 (T15IP)

# Boring bar for exchangeable head

## W3270-A inch



- Screw clamping
- A = Steel version with internal cooling

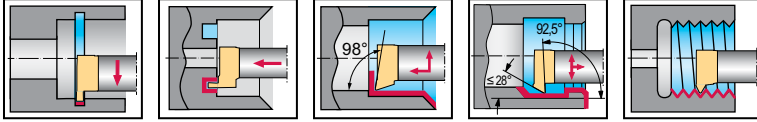

### Tool

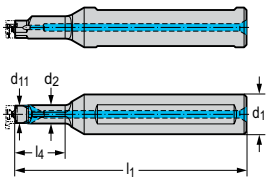

Designation	d <sub>11</sub> inch	d <sub>2</sub> inch	d <sub>1</sub> inch	l <sub>1</sub> inch	l <sub>4</sub> inch
★ W3270.A0500-21-WE05	0,197	0,236	0,500	3,004	0,681
★ W3270.A0625-12-WE05	0,197	0,236	0,625	3,004	0,327
★ W3270.A0625-16-WE07	0,276	0,354	0,625	3,665	0,476
★ W3270.A0625-20-WE09	0,354	0,433	0,625	3,732	0,583
★ W3270.A0625-24-WE07	0,276	0,354	0,625	3,98	0,791
★ W3270.A0625-30-WE09	0,354	0,433	0,625	3,732	0,976

Parallel shank with clamping surface

Bodies and assembly parts are included in the scope of delivery

### Assembly parts

	d <sub>11</sub> [inch]	0,197	0,276	0,354
Clamping screw Tightening torque		FS2676 (T7IP) 0,59 lbs	FS2692 (T9IP) 1,549 lbs	FS2679 (T15IP) 3,319 lbs
Torx key		FS1490 (T7IP)	FS1466 (T9IP)	FS1465 (T15IP)



# Boring bar for exchangeable head

## W3270-E inch

- Screw clamping
- E = Solid carbide version with internal cooling



A2

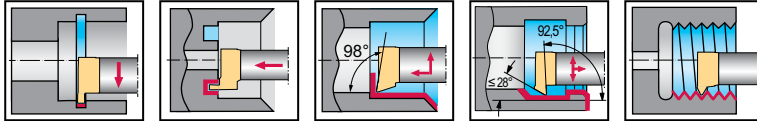

### Tool

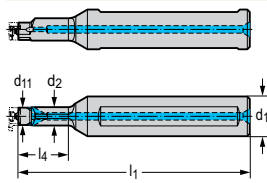

Parallel shank with clamping surface

Designation	d <sub>11</sub> inch	d <sub>2</sub> inch	d <sub>1</sub> inch	l <sub>1</sub> inch	l <sub>4</sub> inch
★ W3270.E0500-20-WE09	0,354	0,433	0,500	2,953	0,583
★ W3270.E0500-21-WE05	0,197	0,236	0,500	3,004	0,681
★ W3270.E0500-22-WE07	0,276	0,354	0,500	3,390	0,713
★ W3270.E0500-30-WE05	0,197	0,236	0,500	3,398	1,035
★ W3270.E0500-32-WE07	0,276	0,354	0,500	3,783	1,106
★ W3270.E0500-34-WE09	0,354	0,433	0,500	3,732	1,134
★ W3270.E0500-42-WE05	0,197	0,236	0,500	3,791	1,508
★ W3270.E0500-45-WE09	0,354	0,433	0,500	4,126	1,543
★ W3270.E0500-48-WE07	0,276	0,354	0,500	4,374	1,736
★ W3270.E0500-64-WE07	0,276	0,354	0,500	4,965	2,366
★ W3270.E0500-64-WE09	0,354	0,433	0,500	4,913	2,315
★ W3270.E0625-45-WE09	0,354	0,433	0,625	4,331	1,567
★ W3270.E0625-64-WE09	0,354	0,433	0,625	4,913	2,315

Bodies and assembly parts are included in the scope of delivery

### Assembly parts

	d <sub>11</sub> [inch]	0,197	0,276	0,354
Clamping screw Tightening torque		FS2676 (T7IP) 0,59 lbs	FS2692 (T9IP) 1,549 lbs	FS2679 (T15IP) 3,319 lbs
Torx key		FS1490 (T7IP)	FS1466 (T9IP)	FS1465 (T15IP)

# Boring bar for exchangeable head – Axial grooving

**W3271-E** mm

- Screw clamping
- E = Solid carbide version with internal cooling

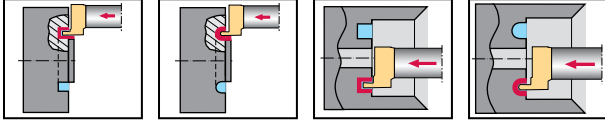

## Tool

		Designation	d <sub>11</sub> mm	d <sub>2</sub> mm	d <sub>1</sub> mm	l <sub>1</sub> mm	l <sub>4</sub> mm
		★ W3271-E16R-42-WE09	9	13	16	94,7	37
	Parallel shank with clamping surface						
		★ W3271-E16L-42-WE09	9	13	16	94,7	37
	Parallel shank with clamping surface						

Bodies and assembly parts are included in the scope of delivery

## Assembly parts

	d <sub>11</sub> [mm]	9
	Clamping screw Tightening torque	FS2679 (T15IP) 4,5 Nm
	Torx key	FS1465 (T15IP)

# Boring bar for exchangeable head – Axial grooving

W3271-E inch



A2

- Screw clamping
- E = Solid carbide version with internal cooling

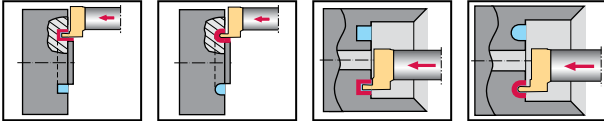

Tool		Designation	d <sub>11</sub> inch	d <sub>2</sub> inch	d <sub>1</sub> inch	l <sub>1</sub> inch	l <sub>4</sub> inch
	★	W3271.E0625R-42-WE09	0,354	0,433	0,625	3,728	1,445
		Parallel shank with clamping surface					
	★	W3271.E0625L-42-WE09	0,354	0,433	0,625	3,728	1,445
		Parallel shank with clamping surface					

Bodies and assembly parts are included in the scope of delivery

Assembly parts		d <sub>11</sub> [inch]	0,354
	Clamping screw Tightening torque		FS2679 (T15IP) 3,319 lbs
	Torx key		FS1465 (T15IP)

## Exchangeable head – Internal grooving

G4221-Q...-P mm

### Walter Cut

- QuadFit
- For Accure-tec boring bars

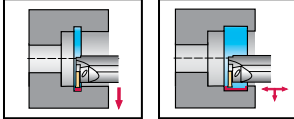
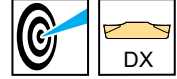

#### Tool

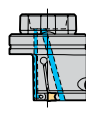

QuadFit

Designation

s  
mm

T<sub>max</sub>  
mm

d<sub>1</sub>

D<sub>min</sub>  
mm

f  
mm

l<sub>4</sub>  
mm

l<sub>21</sub>  
mm

s<sub>1</sub>  
mm

Type

G4221-Q32R-3T12DX18-P

3

12

Q32

50

29,7

22,4

30,5

2,4

DX18-3E3 ..

G4221-Q40R-3T12DX18-P

3

12

Q40

55

33,7

22,4

30,5

2,4

DX18-3F3 ..

G4221-Q50R-3T12DX18-P

3

12

Q50

80

38,7

22,3

30,5

2,4

G4221-Q32R-4T12DX18-P

4

12

Q32

50

29,7

22,4

30

3,4

DX18-4E4 ..

G4221-Q40R-4T12DX18-P

4

12

Q40

55

33,7

22,4

30

3,4

DX18-4F4 ..

G4221-Q50R-4T21DX18-P

4

21

Q50

80

47,7

22,3

30

3,4

G4221-Q32L-3T12DX18-P

3

12

Q32

50

29,7

22,4

30,5

2,4

DX18-3E3 ..

G4221-Q40L-3T12DX18-P

3

12

Q40

55

33,7

22,4

30,5

2,4

DX18-3F3 ..

G4221-Q50L-3T12DX18-P

3

12

Q50

80

38,7

22,3

30,5

2,4

G4221-Q32L-4T12DX18-P

4

12

Q32

50

29,7

22,4

30

3,4

DX18-4E4 ..

G4221-Q40L-4T12DX18-P

4

12

Q40

55

33,7

22,4

30

3,4

DX18-4F4 ..

G4221-Q50L-4T21DX18-P

4

21

Q50

80

47,7

22,3

30

3,4

Dimensional drawing shows right-hand version. |  $l_1 = l_{21} + s/2$  | The maximum recommended coolant pressure is 150 bar (2175 psi) | Refer to the Walter online catalogue for more product information: [www.walter-tools.com](http://www.walter-tools.com) | Bodies and assembly parts are included in the scope of delivery

#### Assembly parts

	D <sub>min</sub> [mm]	50–80
	Clamping screw for grooving insert Tightening torque	FS2614 (T20IP) 5 Nm
	Threaded plug	M03X006 ISO 4026
	Allen key	FS1464 (T20IP)

#### Accessories

	D <sub>min</sub> [mm]	50–80
	Torque screwdriver, digital	FS2248
	Interchangeable blade	FS2015 (T20IP)
	Torque screwdriver, analogue	FS2003

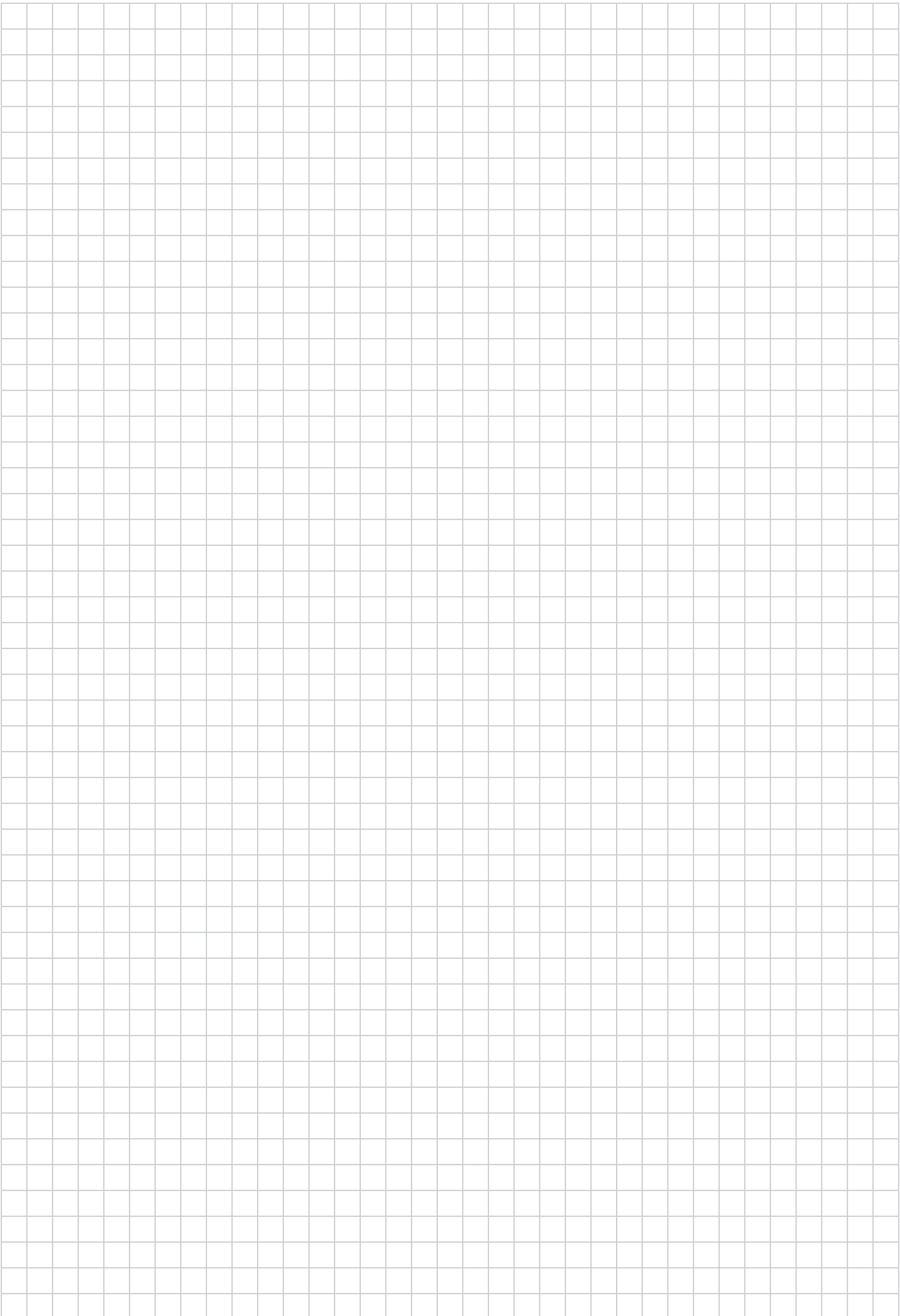

A3

## Indexable inserts

Machining	External machining				
	<b>NEW</b>	<b>NEW</b>	<b>NEW</b>	<b>NEW</b>	<b>NEW</b>
Indexable inserts					
Thread type	55° partial profile	60° partial profile	full profile, ACME / STUB ACME 29°	full profile, American NPT 60°	full profile, American NPTF 60°
P Steel	●●	●●	●●	●●	●●
M Stainless steel	●●	●●	●●	●●	●●
K Cast iron	●	●	●	●	●
N NF metals	●	●	●	●	●
S Materials with difficult cutting properties					
H Hard materials					
O Other	●	●	●	●	●
Pitch P [mm]	0,5–3,0	0,5–5,0			
Pitch in threads per inch [TPI]	14,0–16,0	5,0–16,0	5,0–16,0	8,0–27,0	11,5–18,0
Page in catalogue	A 580	A 580	A 582	A 582	A 582
QR code					
www.walter-tools.com/woc/	TS	TS	TS	TS	TS

Machining	External machining				
	<b>NEW</b>	<b>NEW</b>	<b>NEW</b>	<b>NEW</b>	<b>NEW</b>
Indexable inserts					
Thread type	full profile, American UN 60°	full profile, American UNJ 60°	full profile, BSPT 55°	full profile, BUT 45°	full profile, ISO metric 60°
P Steel	●●	●●	●●	●●	●●
M Stainless steel	●●	●●	●●	●●	●●
K Cast iron	●	●	●	●	●
N NF metals	●	●	●	●	●
S Materials with difficult cutting properties					
H Hard materials					
O Other	●	●	●	●	●
Pitch P [mm]					0,5–5,0
Pitch in threads per inch [TPI]	6,0–40,0	8,0–32,0	11,0–19,0	12,0	
Page in catalogue	A 582	A 582	A 582	A 582	A 582
QR code					
www.walter-tools.com/woc/	TS	TS	TS	TS	TS

**WALTER SELECT**

●● Primary application ● Other application

# Indexable inserts

Machining	External machining			Internal machining	
Indexable inserts					
Thread type	full profile, RD 30°	full profile, TR 30°	full profile, Whitworth 55°	55° partial profile	60° partial profile
<b>P</b> Steel	●●	●●	●●	●●	●●
<b>M</b> Stainless steel	●●	●●	●●	●●	●●
<b>K</b> Cast iron	●	●	●	●	●
<b>N</b> NF metals	●	●	●	●	●
<b>S</b> Materials with difficult cutting properties					
<b>H</b> Hard materials					
<b>O</b> Other	●	●	●	●	●
Pitch P [mm]		2,0–5,0		0,5–1,5	0,5–5,0
Pitch in threads per inch [TPI]	6,0–8,0		7,0–28,0	16,0–48,0	5,0–48,0
Page in catalogue	A 582	A 582	A 582	A 581	A 581
QR code					
www.walter-tools.com/woc/	TS	TS	TS	NTS	NTS

Machining	Internal machining		
Indexable inserts			
Thread type	full profile, American UN 60°	full profile, ISO metric 60°	full profile, Whitworth
<b>P</b> Steel	●●	●●	●●
<b>M</b> Stainless steel	●●	●●	●●
<b>K</b> Cast iron	●	●	●
<b>N</b> NF metals	●	●	●
<b>S</b> Materials with difficult cutting properties			
<b>H</b> Hard materials			
<b>O</b> Other	●	●	●
Pitch P [mm]		0,5–5,0	
Pitch in threads per inch [TPI]	8,0–64,0	5,08–50,8	8,0–48,0
Page in catalogue	A 592		
QR code			
www.walter-tools.com/woc/	NTS	NTS	NTS

## External thread turning inserts – 60° partial profile

TS

Tiger-tec® Gold

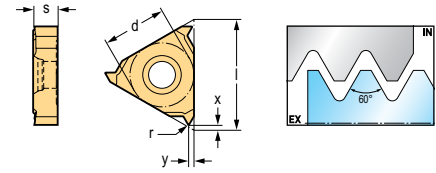

A3

## Indexable inserts

Designation	Pitch (P) mm	Pitch (P) in	Z	r mm	l mm	d mm	h <sub>min</sub> mm	X mm	Y mm	P		M		S		
										HC	WMP 22G	HC	WMP 22G	HC	WMP 22G	
	TS16-ER-A60	0,5–1,5	16–48	1	0,08	16	9,525	1,25	0,6	0,8	HC	WMP 22G	HC	WMP 22G	HC	WMP 22G
	TS16-ER-AG60	0,5–3	8–48	1	0,08	16	9,525	2,4	1,1	1,5	HC	WMP 32G	HC	WMP 32G	HC	WMP 32G
	TS16-ER-G60	1,75–3	8–14	1	0,18	16	9,525	2,3	1,1	1,5	HC	WMP 22G	HC	WMP 22G	HC	WMP 22G
	TS22-ER-N60	3,5–5	5–7	1	0,4	22	12,7	3,49	1,8	2,5	HC	WMP 22G	HC	WMP 22G	HC	WMP 22G
	TS16-EL-A60	0,5–1,5	16–48	1	0,08	16	9,525	1,25	0,6	0,8	HC	WMP 22G	HC	WMP 22G	HC	WMP 22G
	TS16-EL-AG60	0,5–3	8–48	1	0,08	16	9,525	2,4	1,1	1,5	HC	WMP 32G	HC	WMP 32G	HC	WMP 32G
	TS16-EL-G60	1,75–3	14–8	1	0,18	16	9,525	2,3	1,1	1,5	HC	WMP 22G	HC	WMP 22G	HC	WMP 22G
	TS22-EL-N60	3,5–5	7–5	1	0,4	22	12,7	3,49	1,8	2,5	HC	WMP 22G	HC	WMP 22G	HC	WMP 22G
	TS16-ER-A60-F5	0,5–1,5	16–48	1	0,08	16	9,525	1,28	0,6	0,8	HC	WMP 22G	HC	WMP 22G	HC	WMP 22G
	TS16-ER-AG60-F5	0,5–3	8–48	1	0,08	16	9,525	2,5	1,1	1,5	HC	WMP 32G	HC	WMP 32G	HC	WMP 32G
	TS16-ER-G60-F5	1,75–3	8–14	1	0,18	16	9,525	2,4	1,2	1,5	HC	WMP 22G	HC	WMP 22G	HC	WMP 22G
	TS16-ER-A60-M5	0,5–1,5	16–48	1	0,08	16	9,525	1,28	0,6	0,8	HC	WMP 22G	HC	WMP 22G	HC	WMP 22G
	TS16-ER-AG60-M5	1,75–3	8–48	1	0,08	16	9,525	2,5	1,1	1,5	HC	WMP 32G	HC	WMP 32G	HC	WMP 32G

Dimensional drawing shows right-hand version.

HC = Coated carbide

## External thread turning inserts – 55° partial profile

TS

Tiger-tec® Gold

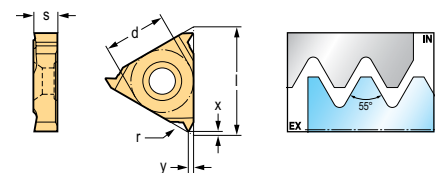

## Indexable inserts

Designation	Pitch (P) mm	Pitch (P) in	Z	r mm	l mm	d mm	h <sub>min</sub> mm	X mm	Y mm	P		M		S		
										HC	WMP 32G	HC	WMP 32G	HC	WMP 32G	
	TS16-ER-A55	0,5–1,5	16–48	1	0,08	16	9,525	1,42	0,6	0,8	HC	WMP 32G	HC	WMP 32G	HC	WMP 32G
	TS16-ER-AG55	0,5–3	8–48	1	0,08	16	9,525	2,46	1,1	1,5	HC	WMP 32G	HC	WMP 32G	HC	WMP 32G
	TS16-ER-G55	1,75–3	8–14	1	0,2	16	9,525	2,3	1,1	1,5	HC	WMP 22G	HC	WMP 22G	HC	WMP 22G
	TS16-EL-A55	0,5–1,5	16–48	1	0,08	16	9,525	1,42	0,6	0,8	HC	WMP 32G	HC	WMP 32G	HC	WMP 32G
	TS16-ER-AG55-F5	0,5–3	8–48	1	0,08	16	9,525	2,46	1,1	1,5	HC	WMP 32G	HC	WMP 32G	HC	WMP 32G
	TS16-ER-G55-F5	1,75–3	8–14	1	0,2	16	9,525	2,32	1,2	1,5	HC	WMP 22G	HC	WMP 22G	HC	WMP 22G

Dimensional drawing shows right-hand version.

HC = Coated carbide

WALTER SELECT

Optimum indexable insert for → Good = 😊 → Average = 😐 → Poor = 😞 machining conditions



# Internal thread turning inserts – 60° partial profile NTS

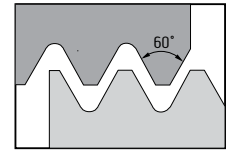
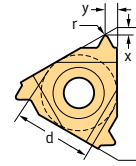

A3

## Indexable inserts

Designation	Pitch (P) mm	Pitch (P) in	l mm	d mm	r mm	X mm	Y mm	P		M	
								HC		HC	
								WXM20	WXP20	WMP32	WXM20
 NTS-IL-11 A60	0,5-1,5	48-16	11	6,35	0,05	0,8	0,9	☺	☺	☺	☺
NTS-IL-16 AG60	0,5-3	48-8	16	9,525	0,05	1,2	1,7	☺	☺	☺	☺
NTS-IL-16 G60	1,75-3	14-8	16	9,525	0,16	1,2	1,7	☺	☺	☺	☺
NTS-IR-11 A60	0,5-1,5	48-16	11	6,35	0,05	0,8	0,9	☺	☺	☺	☺
NTS-IR-16 AG60	0,5-3	48-8	16	9,525	0,05	1,2	1,7	☺	☺	☺	☺
NTS-IR-16 G60	1,75-3	14-8	16	9,525	0,16	1,2	1,7	☺	☺	☺	☺
NTS-IR-22 N60	3,5-5	7-5	22	12,7	0,53	1,7	2,5	☺	☺	☺	☺
NTS-IL-11 A55	0,5-1,5	48-16	11	6,35	0,05	0,8	0,9	☺	☺	☺	☺
NTS-IR-11 A55	0,5-1,5	48-16	11	6,35	0,05	0,8	0,9	☺	☺	☺	☺

Ordering example for the grade WMP32: NTS-IL-11 A60 WMP32

HC = Coated carbide

## External thread turning inserts – full profile, ISO metric 60°

TS

Tiger-tec® Gold

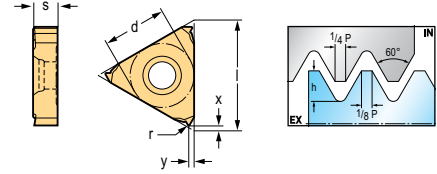

A3

## Indexable inserts

Designation	Pitch (P) mm	Z	r mm	l mm	d mm	h <sub>min</sub> mm	X mm	Y mm	P		M		S	
									HC	WMP22G	HC	WMP32G	HC	WMP22G
	TS16-ER0.5ISO	0.5	1	0.06	16	9,525	0.3	0.8	0.8	☑	☑	☑	☑	☑
	TS16-ER0.70ISO	0.7	1	0.09	16	9,525	0.42	0.8	0.8	☑	☑	☑	☑	☑
	TS16-ER0.75ISO	0.75	1	0.11	16	9,525	0.45	0.8	0.8	☑	☑	☑	☑	☑
	TS16-ER0.8ISO	0.8	1	0.11	16	9,525	0.48	0.8	0.6	☑	☑	☑	☑	☑
	TS16-ER1.0ISO	1	1	0.14	16	9,525	0.61	0.8	0.8	☑	☑	☑	☑	☑
	TS16-ER1.25ISO	1.25	1	0.17	16	9,525	0.77	0.8	0.8	☑	☑	☑	☑	☑
	TS16-ER1.5ISO	1.5	1	0.22	16	9,525	0.89	0.8	0.8	☑	☑	☑	☑	☑
	TS16-ER1.75ISO	1.75	1	0.25	16	9,525	1.07	1.2	1.5	☑	☑	☑	☑	☑
	TS16-ER2.0ISO	2	1	0.29	16	9,525	1.21	1.2	1.5	☑	☑	☑	☑	☑
	TS16-ER2.5ISO	2.5	1	0.34	16	9,525	1.54	1.2	1.5	☑	☑	☑	☑	☑
	TS16-ER3.0ISO	3	1	0.42	16	9,525	1.83	1.2	1.5	☑	☑	☑	☑	☑
	TS22-ER3.5ISO	3.5	1	0.47	22	12.7	2.13	1.8	2.5	☑	☑	☑	☑	☑
TS22-ER4.0ISO	4	1	0.53	22	12.7	2.48	1.8	2.5	☑	☑	☑	☑	☑	
TS22-ER4.5ISO	4.5	1	0.59	22	12.7	2.81	1.8	2.5	☑	☑	☑	☑	☑	
TS22-ER5.0ISO	5	1	0.66	22	12.7	3.12	1.8	2.5	☑	☑	☑	☑	☑	
	TS16-EL0.5ISO	0.5	1	0.06	16	9,525	0.3	0.8	0.8	☑	☑	☑	☑	☑
	TS16-EL0.75ISO	0.75	1	0.09	16	9,525	0.45	0.8	0.8	☑	☑	☑	☑	☑
	TS16-EL0.8ISO	0.8	1	0.11	16	9,525	0.48	0.8	0.8	☑	☑	☑	☑	☑
	TS16-EL1.0ISO	1	1	0.12	16	9,525	0.61	0.8	0.8	☑	☑	☑	☑	☑
	TS16-EL1.25ISO	1.25	1	0.15	16	9,525	0.77	0.8	0.8	☑	☑	☑	☑	☑
	TS16-EL1.5ISO	1.5	1	0.22	16	9,525	0.89	0.8	0.8	☑	☑	☑	☑	☑
	TS16-EL1.75ISO	1.75	1	0.22	16	9,525	1.07	1.2	1.5	☑	☑	☑	☑	☑
	TS16-EL2.0ISO	2	1	0.29	16	9,525	1.21	1.2	1.5	☑	☑	☑	☑	☑
	TS16-EL2.5ISO	2.5	1	0.31	16	9,525	1.54	1.2	1.5	☑	☑	☑	☑	☑
	TS16-EL3.0ISO	3	1	0.42	16	9,525	1.83	1.2	1.5	☑	☑	☑	☑	☑
	TS22-EL3.5ISO	3.5	1	0.47	22	12.7	2.13	1.8	2.5	☑	☑	☑	☑	☑
	TS22-EL4.0ISO	4	1	0.53	22	12.7	2.48	1.8	2.5	☑	☑	☑	☑	☑
TS22-EL4.5ISO	4.5	1	0.59	22	12.7	2.81	1.8	2.5	☑	☑	☑	☑	☑	
TS22-EL5.0ISO	5	1	0.66	22	12.7	3.12	1.8	2.5	☑	☑	☑	☑	☑	
	TS16-ER1.0ISO-F5	1	1	0.14	16	9,525	0.61	0.8	0.8	☑	☑	☑	☑	☑
	TS16-ER1.25ISO-F5	1.25	1	0.17	16	9,525	0.77	0.8	0.8	☑	☑	☑	☑	☑
	TS16-ER1.5ISO-F5	1.5	1		16	9,525	0.89	0.8	0.8	☑	☑	☑	☑	☑
	TS16-ER1.75ISO-F5	1.75	1	0.25	16	9,525	1.07	1.2	1.5	☑	☑	☑	☑	☑
	TS16-ER2.0ISO-F5	2	1	0.29	16	9,525	1.21	1.2	1.5	☑	☑	☑	☑	☑
	TS16-ER3.0ISO-F5	3	1	0.42	16	9,525	1.83	1.2	1.5	☑	☑	☑	☑	☑
	TS16-ER1.0ISO-M5	1	1	0.14	16	9,525	0.61	0.8	0.8	☑	☑	☑	☑	☑
	TS16-ER1.25ISO-M5	1.25	1	0.17	16	9,525	0.77	0.8	0.8	☑	☑	☑	☑	☑
	TS16-ER1.5ISO-M5	1.5	1	0.22	16	9,525	0.89	0.8	0.8	☑	☑	☑	☑	☑
	TS16-ER1.75ISO-M5	2	1	0.25	16	9,525	1.07	1.2	1.5	☑	☑	☑	☑	☑
	TS16-ER2.0ISO-M5	2	1	0.29	16	9,525	1.21	1.2	1.5	☑	☑	☑	☑	☑
	TS16-ER3.0ISO-M5	3	1	0.42	16	9,525	1.83	1.2	1.5	☑	☑	☑	☑	☑

Dimensional drawing shows right-hand version.

HC = Coated carbide

WALTER SELECT

Optimum indexable insert for → Good = ☺ → Average = ☹ → Poor = ☹ machining conditions

## External thread turning inserts – full profile, ISO metric 60°

TS

**Tiger-tec® Gold**

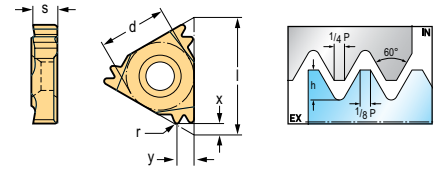

### Indexable inserts

Designation	Pitch (P) mm	Z	r mm	l mm	d mm	h <sub>min</sub> mm	X mm	Y mm	P	M	S	
									HC	HC	HC	
	TS16-ER1.0ISO-3	1	3	0.14	16	9,525	0.61	1.5	2.4	WMP32G	WMP32G	WMP32G
	TS16-ER1.5ISO-2	1.5	2	0.22	16	9,525	0.89	1.5	2.2	☞	☞	☞
	TS22-ER1.5ISO-3	1.5	3	0.22	22	12.7	0.89	2.3	3.6	☞	☞	☞
	TS16-ER2.0ISO-2	2	2	0.29	16	9,525	1.21	1.6	2.4	☞	☞	☞
	TS22-ER2.0ISO-2	2	2	0.29	22	12.7	1.2	2	2.9	☞	☞	☞

Dimensional drawing shows right-hand version.

HC = Coated carbide

## External thread turning inserts – full profile, American UN 60°

TS

**Tiger-tec® Gold**

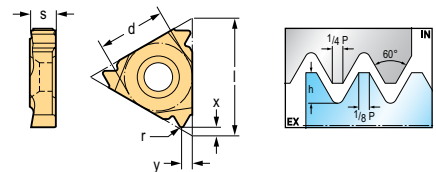

### Indexable inserts

Designation	Lead (TPI)	Z	r mm	l mm	d mm	h <sub>min</sub> mm	X mm	Y mm	P	M	S
									HC	HC	HC
	TS22-ER6UN	6	1	0.52	22	12.7	2.65	2.5	WMP22G	WMP32G	WMP32G
	TS22-ER7UN	7	1	0.47	22	12.7	2.23	1.8	2.5	☞	☞
	TS16-ER08UN	8	1	0.38	16	9,525	2.02	1.2	1.5	☞	☞
	TS16-ER09UN	9	1	0.34	16	9,525	1.79	1.2	1.5	☞	☞
	TS16-ER10UN	10	1	0.34	16	9,525	1.55	1.2	1.5	☞	☞
	TS16-ER11UN	11	1	0.28	16	9,525	1.47	1.2	1.5	☞	☞
	TS16-ER12UN	12	1	0.26	16	9,525	1.32	1.2	1.5	☞	☞
	TS16-ER13UN	13	1	0.24	16	9,525	1.25	1.2	1.5	☞	☞
	TS16-ER14UN	14	1	0.22	16	9,525	1.16	1.2	1.5	☞	☞
	TS16-ER16UN	16	1	0.22	16	9,525	0.96	1.2	0.8	☞	☞
	TS16-ER18UN	18	1	0.18	16	9,525	0.86	1.2	0.8	☞	☞
	TS16-ER20UN	20	1	0.16	16	9,525	0.77	0.8	0.8	☞	☞
	TS16-ER24UN	24	1	0.13	16	9,525	0.67	0.8	0.8	☞	☞
	TS16-ER28UN	28	1	0.11	16	9,525	0.57	0.8	0.8	☞	☞
	TS16-ER32UN	32	1	0.09	16	9,525	0.51	0.8	0.8	☞	☞
	TS16-ER40UN	40	1	0.08	16	9,525	0.39	1.2	0.5	☞	☞

Dimensional drawing shows right-hand version.

HC = Coated carbide

**WALTER SELECT** Optimum indexable insert for → Good = ☺ → Average = ☹ → Poor = ☹ machining conditions

A3

## External thread turning inserts – full profile, American UN 60°

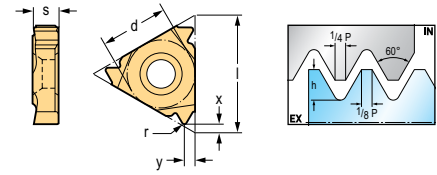

TS

Tiger-tec® Gold



A3

## Indexable inserts

Designation	Lead (TPI)	Z	r mm	l mm	d mm	h <sub>min</sub> mm	X mm	Y mm	P		M		S	
									HC	WMP32G	HC	WMP32G	HC	WMP32G
 TS22-EL06UN	6	1	0,52	22	12,7	2,65	2	2,5	HC	WMP32G	HC	WMP32G	HC	WMP32G
TS22-EL07UN	7	1	0,47	22	12,7	2,23	1,8	2,5	HC	WMP32G	HC	WMP32G	HC	WMP32G
TS16-EL08UN	8	1	0,38	16	9,525	2,02	1,2	1,5	HC	WMP32G	HC	WMP32G	HC	WMP32G
TS16-EL10UN	10	1	0,31	16	9,525	1,61	1,2	1,5	HC	WMP32G	HC	WMP32G	HC	WMP32G
TS16-EL11UN	11	1	0,28	16	9,525	1,47	1,2	1,5	HC	WMP32G	HC	WMP32G	HC	WMP32G
TS16-EL12UN	12	1	0,26	16	9,525	1,32	1,2	1,5	HC	WMP32G	HC	WMP32G	HC	WMP32G
TS16-EL14UN	14	1	0,22	16	9,525	1,16	1,2	1,5	HC	WMP32G	HC	WMP32G	HC	WMP32G
TS16-EL16UN	16	1	0,22	16	9,525	0,96	1,2	0,8	HC	WMP32G	HC	WMP32G	HC	WMP32G
TS16-EL18UN	18	1	0,18	16	9,525	0,86	1,2	0,8	HC	WMP32G	HC	WMP32G	HC	WMP32G
TS16-EL20UN	20	1	0,16	16	9,525	0,77	0,8	0,8	HC	WMP32G	HC	WMP32G	HC	WMP32G
TS16-EL24UN	24	1	0,13	16	9,525	0,67	0,8	0,8	HC	WMP32G	HC	WMP32G	HC	WMP32G
TS16-EL28UN	28	1	0,11	16	9,525	0,57	0,8	0,8	HC	WMP32G	HC	WMP32G	HC	WMP32G
TS16-EL32UN	32	1	0,09	16	9,525	0,51	0,8	0,8	HC	WMP32G	HC	WMP32G	HC	WMP32G
 TS16-ER08UN-F5	8	1	0,43	16	9,525	1,94	1,2	1,5	HC	WMP32G	HC	WMP32G	HC	WMP32G
TS16-ER12UN-F5	12	1	0,29	16	9,525	1,29	1,2	1,5	HC	WMP32G	HC	WMP32G	HC	WMP32G
TS16-ER14UN-F5	14	1	0,22	16	9,525	1,11	1,2	1,5	HC	WMP32G	HC	WMP32G	HC	WMP32G
TS16-ER16UN-F5	16	1	0,22	16	9,525	0,96	0,8	0,8	HC	WMP32G	HC	WMP32G	HC	WMP32G
TS16-ER18UN-F5	18	1	0,18	16	9,525	0,86	0,8	0,8	HC	WMP32G	HC	WMP32G	HC	WMP32G
TS16-ER20UN-F5	20	1	0,16	16	9,525	0,77	0,8	0,8	HC	WMP32G	HC	WMP32G	HC	WMP32G

Dimensional drawing shows right-hand version.

HC = Coated carbide

## External thread turning inserts – full profile, American UN 60°

TS

Tiger-tec® Gold

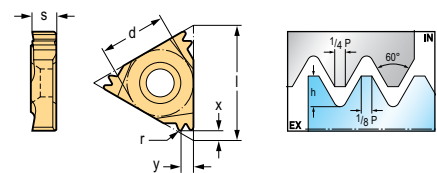

## Indexable inserts

Designation	Lead (TPI)	Z	r mm	l mm	d mm	h <sub>min</sub> mm	X mm	Y mm	P		M		S	
									HC	WMP32G	HC	WMP32G	HC	WMP32G
 TS22-ER12UN-2	12	2	0,26	22	12,7	1,31	2	3,1	HC	WMP32G	HC	WMP32G	HC	WMP32G
TS16-ER16UN-2	16	2	0,21	16	9,525	0,97	1,4	1,9	HC	WMP32G	HC	WMP32G	HC	WMP32G
TS22-ER16UN-3	16	3	0,21	22	12,7	0,97	2,5	4	HC	WMP32G	HC	WMP32G	HC	WMP32G

Dimensional drawing shows right-hand version.

HC = Coated carbide

WALTER SELECT

Optimum indexable insert for → Good = 😊 → Average = 😐 → Poor = 😞 machining conditions

## External thread turning inserts – full profile, American UNJ 60°

TS

**Tiger-tec® Gold**

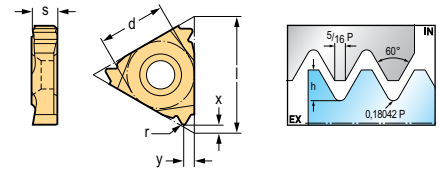

### Indexable inserts

Designation	Lead (TPI)	Z	r mm	l mm	d mm	X mm	Y mm	P		M		S			
								HC	WMP22G	HC	WMP32G	HC	WMP22G	HC	WMP32G
 TS16-ER08UNJ	8	1	0,5	16	9,525	1,2	1,5	HC	WMP22G	HC	WMP32G	HC	WMP22G	HC	WMP32G
TS16-ER10UNJ	10	1	0,41	16	9,525	1,2	1,5	HC	WMP22G	HC	WMP32G	HC	WMP22G	HC	WMP32G
TS16-ER12UNJ	12	1	0,34	16	9,525	1,2	1,5	HC	WMP22G	HC	WMP32G	HC	WMP22G	HC	WMP32G
TS16-ER14UNJ	14	1	0,3	16	9,525	1,2	1,5	HC	WMP22G	HC	WMP32G	HC	WMP22G	HC	WMP32G
TS16-ER16UNJ	16	1	0,26	16	9,525	1,2	0,8	HC	WMP22G	HC	WMP32G	HC	WMP22G	HC	WMP32G
TS16-ER18UNJ	18	1	0,23	16	9,525	1,2	0,8	HC	WMP22G	HC	WMP32G	HC	WMP22G	HC	WMP32G
TS16-ER20UNJ	20	1	0,21	16	9,525	0,8	0,8	HC	WMP22G	HC	WMP32G	HC	WMP22G	HC	WMP32G
TS16-ER24UNJ	24	1	0,18	16	9,525	0,8	0,8	HC	WMP22G	HC	WMP32G	HC	WMP22G	HC	WMP32G
TS16-ER28UNJ	28	1	0,15	16	9,525	0,8	0,8	HC	WMP22G	HC	WMP32G	HC	WMP22G	HC	WMP32G
TS16-ER32UNJ	32	1	0,13	16	9,525	0,8	0,8	HC	WMP22G	HC	WMP32G	HC	WMP22G	HC	WMP32G

Dimensional drawing shows right-hand version.

HC = Coated carbide

## External thread turning inserts – full profile, Whitworth 55°

TS

**Tiger-tec® Gold**

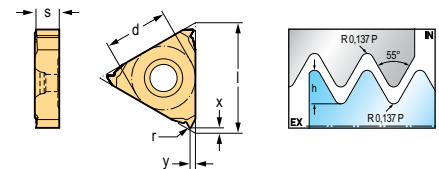

### Indexable inserts

Designation	Lead (TPI)	Z	r mm	l mm	d mm	h <sub>min</sub> mm	X mm	Y mm	P		M		S			
									HC	WMP22G	HC	WMP32G	HC	WMP22G	HC	WMP32G
 TS22-ER07W	7	1	0,43	22	12,7	2,37	1,8	2,5	HC	WMP22G	HC	WMP32G	HC	WMP22G	HC	WMP32G
TS16-ER08W	8	1	0,42	16	9,525	2,04	1,2	1,5	HC	WMP22G	HC	WMP32G	HC	WMP22G	HC	WMP32G
TS16-ER09W	9	1	0,31	16	9,525	1,9	1,2	1,5	HC	WMP22G	HC	WMP32G	HC	WMP22G	HC	WMP32G
TS16-ER10W	10	1	0,27	16	9,525	1,71	1,2	1,5	HC	WMP22G	HC	WMP32G	HC	WMP22G	HC	WMP32G
TS16-ER11W	11	1	0,3	16	9,525	1,48	1,2	1,5	HC	WMP22G	HC	WMP32G	HC	WMP22G	HC	WMP32G
TS16-ER12W	12	1	0,24	16	9,525	1,41	1,2	1,5	HC	WMP22G	HC	WMP32G	HC	WMP22G	HC	WMP32G
TS16-ER14W	14	1	0,24	16	9,525	1,15	1,2	1,5	HC	WMP22G	HC	WMP32G	HC	WMP22G	HC	WMP32G
TS16-ER16W	16	1	0,2	16	9,525	1,03	0,8	0,8	HC	WMP22G	HC	WMP32G	HC	WMP22G	HC	WMP32G
TS16-ER18W	18	1	0,16	16	9,525	0,97	0,8	0,8	HC	WMP22G	HC	WMP32G	HC	WMP22G	HC	WMP32G
TS16-ER19W	19	1	0,15	16	9,525	0,92	0,8	0,8	HC	WMP22G	HC	WMP32G	HC	WMP22G	HC	WMP32G
TS16-ER20W	20	1	0,14	16	9,525	0,89	0,8	0,8	HC	WMP22G	HC	WMP32G	HC	WMP22G	HC	WMP32G
TS16-ER28W	28	1	0,09	16	9,525	0,66	0,8	0,8	HC	WMP22G	HC	WMP32G	HC	WMP22G	HC	WMP32G

Dimensional drawing shows right-hand version.

HC = Coated carbide

**WALTER SELECT**

Optimum indexable insert for → Good = 😊 → Average = 😐 → Poor = 😞 machining conditions

🌟 🌟 🌟 / ★ = New addition to the product range

Indexable inserts A 585

A3

## External thread turning inserts – full profile, Whitworth 55°

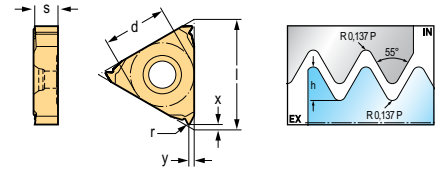

TS

Tiger-tec® Gold



A3

## Indexable inserts

Designation	Lead (TPI)	Z	r mm	l mm	d mm	h <sub>min</sub> mm	X mm	Y mm	P		M		S	
									HC	WMP32G	HC	WMP32G	HC	WMP32G
 TS16-EL08W	8	1	0.42	16	9,525	2,04	1,2	1,5	✔	✔	✔	✔	✔	✔
TS16-EL11W	11	1	0.3	16	9,525	1,48	1,2	1,5	✔	✔	✔	✔	✔	✔
TS16-EL12W	12	1	0.24	16	9,525	1,41	1,2	1,5	✔	✔	✔	✔	✔	✔
TS16-EL14W	14	1	0.24	16	9,525	1,15	1,2	1,5	✔	✔	✔	✔	✔	✔
TS16-EL16W	16	1	0.2	16	9,525	1,03	0,8	0,8	✔	✔	✔	✔	✔	✔
TS16-EL19W	19	1	0.15	16	9,525	0,92	0,8	0,8	✔	✔	✔	✔	✔	✔
TS16-EL20W	20	1	0.14	16	9,525	0,89	0,8	0,8	✔	✔	✔	✔	✔	✔
TS16-EL28W	28	1	0.09	16	9,525	0,66	0,8	0,8	✔	✔	✔	✔	✔	✔
 TS16-ER11W-F5	11	1	0.3	16	9,525	1,48	1,2	1,5	✔	✔	✔	✔	✔	✔
TS16-ER14W-F5	14	1	0.24	16	9,525	1,15	1,2	1,5	✔	✔	✔	✔	✔	✔
TS16-ER19W-F5	19	1	0.16	16	9,525	0,88	0,8	0,8	✔	✔	✔	✔	✔	✔

Dimensional drawing shows right-hand version.

HC = Coated carbide

## External thread turning inserts – full profile, Whitworth 55°

TS

Tiger-tec® Gold

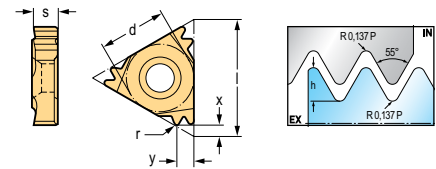

## Indexable inserts

Designation	Lead (TPI)	Z	r mm	l mm	d mm	h <sub>min</sub> mm	X mm	Y mm	P		M		S	
									HC	WMP32G	HC	WMP32G	HC	WMP32G
 TS22-ER11W-2	11	2	0.3	22	12,7	1,48	2,3	3,5	✔	✔	✔	✔	✔	✔

Dimensional drawing shows right-hand version.

HC = Coated carbide

## External thread turning inserts – full profile, American NPTF 60°

TS

**Tiger-tec® Gold**

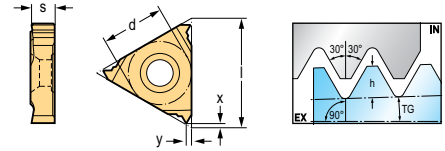

### Indexable inserts

Designation	Lead (TPI)	Z	l mm	d mm	h <sub>min</sub> mm	X mm	Y mm	P	M	S
								HC	HC	HC
 TS16-ER11.5NPTF	11,5	1	16	9,525	1,69	1,1	1,5	WMP32G	WMP32G	WMP32G
	TS16-ER18NPTF	18	1	16	9,525	1,06	0,7	0,8	WMP32G	WMP32G

Dimensional drawing shows right-hand version.

HC = Coated carbide



## External thread turning inserts – full profile, American NPT 60°

TS

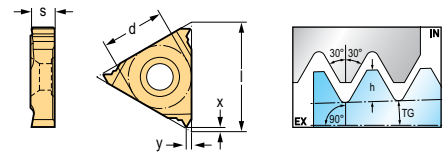
**Tiger-tec® Gold**



### Indexable inserts

Designation	Lead (TPI)	Z	l mm	d mm	h <sub>min</sub> mm	X mm	Y mm	P	M	S	
								HC	HC	HC	
 TS16-ER08NPT	8	1	16	9,525	2,45	1,1	1,6	WMP32G	WMP32G	WMP32G	
	TS16-ER11.5NPT	11,5	1	16	9,525	1,68	1,1	1,5	WMP32G	WMP32G	WMP32G
	TS16-ER14NPT	14	1	16	9,525	1,38	1,1	1,5	WMP32G	WMP32G	WMP32G
	TS16-ER18NPT	18	1	16	9,525	1,06	0,7	0,8	WMP32G	WMP32G	WMP32G
	TS16-ER27NPT	27	1	16	9,525	0,71	0,7	0,8	WMP32G	WMP32G	WMP32G
 TS16-ER11.5NPT-F5	11,5	1	16	9,525	1,64	1,1	1,5	WMP32G	WMP32G	WMP32G	

Dimensional drawing shows right-hand version.

HC = Coated carbide

## External thread turning inserts – full profile, ACME / STUB ACME 29°

TS

Tiger-tec® Gold

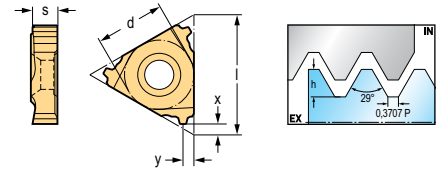

A3

## Indexable inserts

Designation	Lead (TPI)	Z	l mm	d mm	h <sub>min</sub> mm	X mm	Y mm	P	M	S
								HC	HC	HC
								WMP32G	WMP32G	WMP32G
 TS22-ER05ACME	5	1	22	12,7	2,81	2	2,3	☞	☞	☞
TS22-ER06ACME	6	1	22	12,7	2,39	2	2,5	☞	☞	☞
TS22-ER06STACME	6	1	22	12,7	1,58	2,4	2,5	☞	☞	☞
TS16-ER08ACME	8	1	16	9,525	1,86	1,3	1,5	☞	☞	☞
TS16-ER08STACME	8	1	16	9,525	1,86	1,8	1,5	☞	☞	☞
TS16-ER10ACME	10	1	16	9,525	1,57	1,4	1,5	☞	☞	☞
TS16-ER10STACME	10	1	16	9,525	1,1	1,5	1,5	☞	☞	☞
TS16-ER12ACME	12	1	16	9,525	1,22	1,3	1,5	☞	☞	☞
TS16-ER12STACME	12	1	16	9,525	0,83	1,5	1,5	☞	☞	☞
TS16-ER14ACME	14	1	16	9,525	1,08	1,3	1,5	☞	☞	☞
TS16-ER14STACME	14	1	16	9,525	0,74	1,3	1,5	☞	☞	☞
TS16-ER16ACME	16	1	16	9,525	0,94	0,9	0,8	☞	☞	☞

Dimensional drawing shows right-hand version.

HC = Coated carbide

## External thread turning inserts – full profile, BSPT

TS

Tiger-tec® Gold

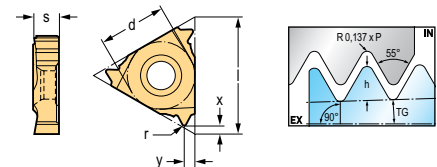

## Indexable inserts

Designation	Lead (TPI)	Z	r mm	l mm	d mm	h <sub>min</sub> mm	X mm	Y mm	P	M	S
									HC	HC	HC
									WMP32G	WMP32G	WMP32G
 TS16-ER11BSPT	11	1	0,3	16	9,525	1,5	1,2	1,5	☞	☞	☞
TS16-ER14BSPT	14	1	0,24	16	9,525	1,16	1,2	1,5	☞	☞	☞
TS16-ER19BSPT	19	1	0,15	16	9,525	0,93	0,8	0,8	☞	☞	☞

Dimensional drawing shows right-hand version.

HC = Coated carbide



# External thread turning inserts – full profile, BUT TS Tiger-tec® Gold

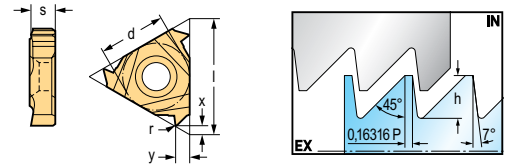

## Indexable inserts

Designation	Lead (TPI)	Z	r mm	l mm	d mm	h <sub>min</sub> mm	X mm	Y mm	P	M	S
									HC	HC	HC
 TS16-ER12BUT	12	1	0.12	16	9.525	1.3	2	1.3	WMP32G	WMP32G	WMP32G

Dimensional drawing shows right-hand version.

HC = Coated carbide

# External thread turning inserts – full profile, RD TS Tiger-tec® Gold

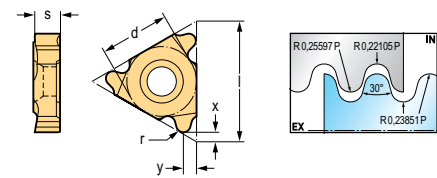

## Indexable inserts

Designation	Lead (TPI)	Z	r mm	l mm	d mm	h <sub>min</sub> mm	X mm	Y mm	P	M	S
									HC	HC	HC
 TS16-ER06RD	6	1	0.97	16	9.525	2.2	1.3	1.8	WMP32G	WMP32G	WMP32G
TS16-ER08RD	8	1	0.73	16	9.525	1.66	1.3	1.5	WMP32G	WMP32G	WMP32G

Dimensional drawing shows right-hand version.

HC = Coated carbide

External thread turning inserts – full profile, TR

TS

**Tiger-tec® Gold**

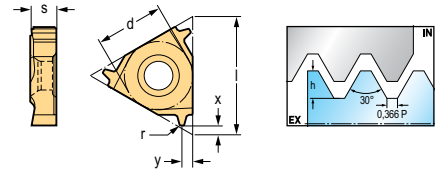

A3

Wendeschneidplatten

Bezeichnung	Steigung P mm	Z	r mm	l mm	d mm	h <sub>min</sub> mm	X mm	Y mm	P	M	S
									HC	HC	HC
 TS16-ER2.0TR	2	1	0,15	16	9,525	1,31	1,3	1,5	WMP32G	WMP32G	WMP32G
TS16-ER3.0TR	3	1	0,15	16	9,525	1,81	1,3	1,6	☹	☹	☹
TS22-ER4.0TR	4	1	0,2	22	12,7	2,31	2	2,5	☹	☹	☹
TS22-ER5.0TR	5	1	0,2	22	12,7	2,81	2	2,3	☹	☹	☹

Maßskizze zeigt rechte Ausführung.

HC = beschichtetes Hartmetall

# Internal thread turning inserts – full profile, ISO metric 60°

## NTS

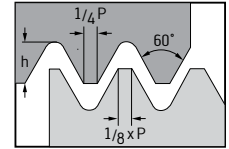
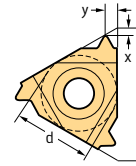

### Wendeschneidplatten

Bezeichnung	Steigung P mm	l mm	d mm	h <sub>min</sub> mm	X mm	Y mm	P		M	
							HC		HC	
							WXM20	WXP20	WMP32	WXM20
NTS-IL-11 0.75ISO	0,75	11	6,35	0,43	0,6	0,6				
NTS-IL-11 0.80ISO	0,8	11	6,35	0,46	0,6	0,6				
NTS-IL-11 1.00ISO	1	11	6,35	0,58	0,6	0,7				
NTS-IL-11 1.25ISO	1,25	11	6,35	0,72	0,8	0,9				
NTS-IL-11 1.50ISO	1,5	11	6,35	0,87	0,8	1				
NTS-IL-11 1.75ISO	1,75	11	6,35	1,01	0,9	1,1				
NTS-IL-11 2.00ISO	2	11	6,35	1,15	0,9	1,1				
NTS-IL-11 2.50ISO	2,5	11	6,35	1,44	0,8	1,1				
NTS-IL-16 0.50ISO	0,5	16	9,525	0,29	0,6	0,4				
NTS-IL-16 0.60ISO	0,6	16	9,525	0,35	0,6	0,6				
NTS-IL-16 0.70ISO	0,7	16	9,525	0,4	0,6	0,6				
NTS-IL-16 0.75ISO	0,75	16	9,525	0,43	0,6	0,6				
NTS-IL-16 0.80ISO	0,8	16	9,525	0,46	0,6	0,6				
NTS-IL-16 1.00ISO	1	16	9,525	0,58	0,6	0,7				
NTS-IL-16 1.50ISO	1,5	16	9,525	0,87	0,8	1				
NTS-IL-16 1.75ISO	1,75	16	9,525	1,01	0,9	1,2				
NTS-IL-16 2.00ISO	2	16	9,525	1,15	1	1,3				
NTS-IL-16 2.50ISO	2,5	16	9,525	1,44	1,1	1,5				
NTS-IL-16 3.00ISO	3	16	9,525	1,73	1,1	1,5				
NTS-IL-22 4.00ISO	4	22	12,7	2,31	1,6	2,3				
NTS-IL-22 4.50ISO	4,5	22	12,7	2,6	1,6	2,4				
NTS-IL-22 5.00ISO	5	22	12,7	2,89	1,6	2,3				
NTS-IR-11 0.75ISO	0,75	11	6,35	0,43	0,6	0,6				
NTS-IR-11 0.80ISO	0,8	11	6,35	0,46	0,6	0,6				
NTS-IR-11 1.00ISO	1	11	6,35	0,58	0,6	0,7				
NTS-IR-11 1.25ISO	1,25	11	6,35	0,72	0,8	0,9				
NTS-IR-11 1.50ISO	1,5	11	6,35	0,87	0,8	1				
NTS-IR-11 1.75ISO	1,75	11	6,35	1,01	0,9	1,1				
NTS-IR-11 2.00ISO	2	11	6,35	1,15	0,9	1,1				
NTS-IR-11 2.50ISO	2,5	11	6,35	1,44	0,8	1,1				
NTS-IR-16 0.50ISO	0,5	16	9,525	0,29	0,6	0,4				
NTS-IR-16 0.60ISO	0,6	16	9,525	0,35	0,6	0,6				
NTS-IR-16 0.70ISO	0,7	16	9,525	0,4	0,6	0,6				
NTS-IR-16 0.75ISO	0,75	16	9,525	0,43	0,6	0,6				
NTS-IR-16 0.80ISO	0,8	16	9,525	0,46	0,6	0,6				
NTS-IR-16 1.00ISO	1	16	9,525	0,58	0,6	0,7				
NTS-IR-16 1.25ISO	1,25	16	9,525	0,72	0,8	0,9				
NTS-IR-16 1.50ISO	1,5	16	9,525	0,87	0,8	1				
NTS-IR-16 1.75ISO	1,75	16	9,525	1,01	0,9	1,2				
NTS-IR-16 2.00ISO	2	16	9,525	1,15	1	1,3				
NTS-IR-16 2.50ISO	2,5	16	9,525	1,44	1,1	1,5				
NTS-IR-16 3.00ISO	3	16	9,525	1,73	1,1	1,5				
NTS-IR-22 3.50ISO	3,5	22	12,7	2,02	1,6	2,3				
NTS-IR-22 4.00ISO	4	22	12,7	2,31	1,6	2,3				
NTS-IR-22 4.50ISO	4,5	22	12,7	2,6	1,6	2,4				
NTS-IR-22 5.00ISO	5	22	12,7	2,89	1,6	2,4				

Bestellbeispiel für die Sorte WMP32: NTS-IL-11 0.75ISO WMP32

HC = beschichtetes Hartmetall

**WALTER SELECT** Optimum indexable insert for → Good = ☺ → Average = ☹ → Poor = ☹ machining conditions

☺ ☹ ☹ / \* = New addition to the product range

A3

# Internal thread turning inserts – full profile, American UN 60° NTS

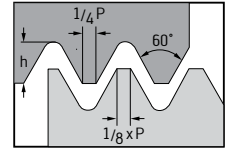
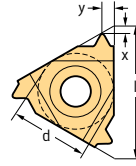

A3

## Indexable inserts

Designation	Lead (TPI)	l mm	d mm	h <sub>min</sub> mm	X mm	Y mm	P		M	
							HC		HC	
							WXM20	WXP20	WMP32	WXM20
NTS-IR-11 11UN	11	11	6.35	1.33	0.8	1.1			☹	☹
NTS-IR-11 12UN	12	11	6.35	1.22	0.8	1.1			☹	☹
NTS-IR-11 14UN	14	11	6.35	1.05	0.9	1.1			☹	☹
NTS-IR-11 16UN	16	11	6.35	0.92	0.9	1.1			☹	☹
NTS-IR-11 18UN	18	11	6.35	0.81	0.8	1			☹	☹
NTS-IR-11 20UN	20	11	6.35	0.73	0.8	0.9			☹	☹
NTS-IR-11 24UN	24	11	6.35	0.61	0.7	0.8			☹	☹
NTS-IR-11 27UN	27	11	6.35	0.54	0.7	0.8			☹	☹
NTS-IR-11 28UN	28	11	6.35	0.52	0.6	0.7			☹	☹
NTS-IR-11 32UN	32	11	6.35	0.46	0.6	0.6			☹	☹
NTS-IR-11 36UN	36	11	6.35	0.41	0.6	0.6			☹	☹
NTS-IR-11 40UN	40	11	6.35	0.37	0.6	0.6			☹	☹
NTS-IR-11 56UN	56	11	6.35	0.26	0.7	0.4			☹	☹
NTS-IR-11 64UN	64	11	6.35	0.23	0.8	0.4			☹	☹
NTS-IR-16 008UN	8	16	9.525	1.83	1.1	1.5	☹		☹	
NTS-IR-16 009UN	9	16	9.525	1.63	1.2	1.7	☹		☹	
NTS-IR-16 010UN	10	16	9.525	1.47	1.1	1.5	☹		☹	
NTS-IR-16 011UN	11	16	9.525	1.33	1.1	1.5	☹		☹	
NTS-IR-16 012UN	12	16	9.525	1.22	1.1	1.4	☹	☹	☹	
NTS-IR-16 013UN	13	16	9.525	1.13	1	1.3	☹		☹	
NTS-IR-16 014UN	14	16	9.525	1.05	0.9	1.2	☹		☹	
NTS-IR-16 016UN	16	16	9.525	0.92	0.9	1.1	☹		☹	
NTS-IR-16 018UN	18	16	9.525	0.81	0.8	1	☹		☹	
NTS-IR-16 020UN	20	16	9.525	0.73	0.8	0.9	☹		☹	

Ordering example for the grade WMP32: NTS-IR-11 11UN WMP32

HC = Coated carbide

# Internal thread turning inserts – full profile, Whitworth NTS

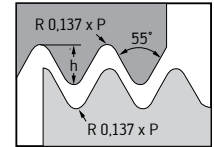
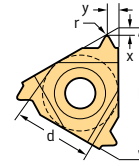

A3

## Indexable inserts

Designation	Lead (TPI)	l mm	d mm	h <sub>min</sub> mm	X mm	Y mm	P			M	
							HC			HC	
							WXM20	WXP20	WMP32	WXM20	WMP32
NTS-IR-11 12W	12	11	6,35	1,32	0,9	1,2			☺	☺	☺
NTS-IR-11 14W	14	11	6,35	1,16	0,9	1,1			☺	☺	☺
NTS-IR-11 16W	16	11	6,35	1,02	0,9	1,1			☺	☺	☺
NTS-IR-11 18W	18	11	6,35	0,9	0,8	1			☺	☺	☺
NTS-IR-11 19W	19	11	6,35	0,86	0,8	1			☺	☺	☺
NTS-IR-11 20W	20	11	6,35	0,81	0,8	0,9			☺	☺	☺
NTS-IR-11 22W	22	11	6,35	0,74	0,8	0,9			☺	☺	☺
NTS-IR-11 24W	24	11	6,35	0,68	0,7	0,8			☺	☺	☺
NTS-IR-11 26W	26	11	6,35	0,63	0,7	0,8			☺	☺	☺
NTS-IR-11 32W	32	11	6,35	0,51	0,6	0,6			☺	☺	☺
NTS-IR-11 36W	36	11	6,35	0,45	0,6	0,6			☺	☺	☺
NTS-IR-11 48W	48	11	6,35	0,34	0,6	0,6			☺	☺	☺
NTS-IR-16 008W	8	16	9,525	2,03	1,2	1,5	☺			☺	
NTS-IR-16 009W	9	16	9,525	1,81	1,2	1,7	☺			☺	
NTS-IR-16 010W	10	16	9,525	1,63	1,1	1,5	☺			☺	
NTS-IR-16 011W	11	16	9,525	1,48	1,1	1,5	☺	☺		☺	
NTS-IR-16 012W	12	16	9,525	1,36	1,1	1,4	☺			☺	
NTS-IR-16 014W	14	16	9,525	1,16	1	1,2	☺	☺		☺	
NTS-IR-16 016W	16	16	9,525	1,02	0,9	1,1	☺			☺	
NTS-IR-16 018W	18	16	9,525	0,9	0,8	1	☺			☺	
NTS-IR-16 019W	19	16	9,525	0,86	0,8	1	☺			☺	

Ordering example for the grade WMP32: NTS-IR-11 12W WMP32

HC = Coated carbide

## Thread turning tools - external machining

Type



Machining

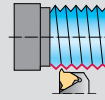

A3

**NEW**
**NEW**
**NEW**

Designation

**T1011**
**T1011...-S**
**T1011-C...**

Version

Square shank

Square shank

Walter Capto™ in acc. with ISO 26623

Clamping system

Claw

Claw

Claw

Coolant supply

External

External

Internal

Walter Capto™ size

C3-C6

Insert size l [mm]

16-22

16-22

16-22

Page in catalogue

A 596

A 596

A 604

QR code

[www.walter-tools.com/woc/](http://www.walter-tools.com/woc/)

T1011

T1011-S

T1011-C

# Threading tools - internal machining

Type



Machining

A3



Designation	A...-NTS-I	S...-NTS-I	C...-NTS-SI	T1820-Q...-P
Version	Parallel shank with clamping surface	Parallel shank with clamping surface	Walter Capto™ in acc. with ISO 26623	QuadFit
Clamping system	Screw	Screw	Screw	Lever-type
Coolant supply	Internal	External	Internal	Precision cooling
Boring bar Ø d <sub>1</sub> [mm]	20	16–40		
Boring bar Ø d <sub>1</sub> [inch]		0,580–1,340		
Walter Capto™ size			C4–C6	
QuadFit size				Q25–Q50
Insert size l [mm]	11–16	16–22	16–22	16–22
Page in catalogue	A 581	A 581	A 608	A 610

QR code

[www.walter-tools.com/woc/](http://www.walter-tools.com/woc/)      A-NTS-I      S-NTS-I      C-NTS-SI      T1820-Q-P

## Shank tool – External thread

 T1011 

A3

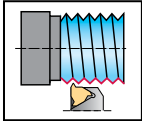











Tool	Designation		h = h <sub>1</sub> mm	b mm	f mm	l <sub>1</sub> mm	l <sub>4</sub> mm	Type	
 Square shank	★ T1011-1212R-TS16	16	12	12	16	100	22	TS16-E	
	★ T1011-1616R-TS16	16	16	16	20	100	22		
	★ T1011-2020R-TS16	16	20	20	25	125	32		
	★ T1011-2525R-TS16	16	25	25	32	150	32		
	★ T1011-3225R-TS16	16	32	25	32	170	32		
	★ T1011-3232R-TS16	16	32	32	40	170	32		
	 Square shank	★ T1011-4040R-TS16	16	40	40	40	200	37	TS22-E
		★ T1011-2525R-TS22	22	25	25	32	150	38	
		★ T1011-3225R-TS22	22	32	25	32	170	38	
		★ T1011-3232R-TS22	22	32	32	40	170	38	
★ T1011-4040R-TS22		22	40	40	40	200	42		
★ T1011-1212L-TS16		16	12	12	16	100	22	TS16-E	
★ T1011-2020L-TS16	16	20	20	25	125	32			
★ T1011-2525L-TS16	16	25	25	32	150	32			
★ T1011-3232L-TS16	16	32	32	40	170	32			
★ T1011-2525L-TS22	22	25	25	32	150	38	TS22-E		
★ T1011-3232L-TS22	22	32	32	40	170	38			

The toolholders listed are designed for an inclination angle of 1° | Refer to the Walter online catalogue for more product information: [www.walter-tools.com](http://www.walter-tools.com) | Bodies and assembly parts are included in the scope of delivery

Assembly parts	Type h = h <sub>1</sub> [mm]	TS16-E 12–16	TS16-E 20–40	TS22-E 25–40
	Clamp		PK273	PK274
	Clamp set	PK275-SET		
	Clamping screw		FS2687 (T15IP) 2,5 Nm	FS2688 (T20IP) 3,9 Nm
	Shim	GX16-1	GX16-1	NX22-1
	Screw for shim	FS2590 (T9IP)	FS2590 (T9IP)	FS2686 (T15IP)
	Tension spring		FS1470	SP1000-76-16
	Torx key	FS1465 (T15IP)	FS1465 (T15IP)	
	Allen key			FS1464 (T20IP)



Accessories			
	Type	TS16-E	TS22-E
	Shim	MX16-1	MX22-1
	Shim	GX16-0	NX22-97.5
	Shim	GX16-2	NX22-98.5
	Shim	GX16-3	NX22-99.5
	Shim	GX16-4	NX22-0.5
	Shim	GX16-98	NX22-1.5
	Shim	GX16-99	NX22-0
	Shim		NX22-2
	Shim		NX22-3
	Shim		NX22-4

A3

## Shank tool – External thread

 T1011...-S 



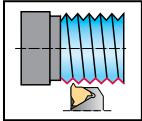







A3



Tool	Designation		h = h <sub>1</sub> mm	b mm	f mm	l <sub>1</sub> mm	l <sub>4</sub> mm	Type
<p>Square shank</p>	★ T1011-1616R-TS16-S	16	16	16	16	100	22	TS16-E
	★ T1011-2020R-TS16-S	16	20	20	20	125	32	
	★ T1011-2525R-TS16-S	16	25	25	25	150	32	
	★ T1011-2525R-TS22-S	22	25	25	25	150	38	TS22-E
<p>Square shank</p>	★ T1011-1616L-TS16-S	16	16	16	16	100	22	TS16-E
	★ T1011-2020L-TS16-S	16	20	20	20	125	32	
	★ T1011-2525L-TS16-S	16	25	25	25	150	32	
	★ T1011-2525L-TS22-S	22	25	25	25	150	38	TS22-E

The toolholders listed are designed for an inclination angle of 1° | Refer to the Walter online catalogue for more product information: [www.walter-tools.com](http://www.walter-tools.com) | Bodies and assembly parts are included in the scope of delivery

Assembly parts	Type h = h <sub>1</sub> (mm)	TS16-E 16	TS16-E 20-25	TS22-E 25
	Clamp		PK273	PK274
	Clamp set	PK275-SET		
	Clamping screw		FS2687 (T15IP) 2,5 Nm	FS2688 (T20IP) 3,9 Nm
	Shim	GX16-1	GX16-1	NX22-1
	Screw for shim	FS2590 (T9IP)	FS2590 (T9IP)	FS2686 (T15IP)
	Tension spring		FS1470	SP1000-76-16
	Torx key	FS1465 (T15IP)	FS1465 (T15IP)	
	Allen key			FS1464 (T20IP)

Accessories			
	Type	TS16-E	TS22-E
	Shim	MX16-1	MX22-1
	Shim	GX16-0	NX22-97.5
	Shim	GX16-2	NX22-98.5
	Shim	GX16-3	NX22-99.5
	Shim	GX16-4	NX22-0.5
	Shim	GX16-98	NX22-1.5
	Shim	GX16-99	NX22-0
	Shim		NX22-2
	Shim		NX22-3
	Shim		NX22-4

A3

## Shank tool – External thread

 T1011 inch



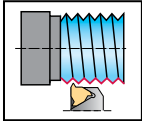







A3



Tool			$h = h_1$ inch	b inch	f inch	$l_1$ inch	$l_4$ inch	Type
<p>Square shank</p>	★ T1011.08R-TS16	16	0,500	0,500	0,625	4,000	0,900	TS16-E
	★ T1011.10R-TS16	16	0,625	0,625	0,750	4,000	0,900	
	★ T1011.16R-TS16	16	1,000	1,000	1,250	6,000	1,100	
	★ T1011.20R-TS16	16	1,250	1,250	1,500	6,000	1,181	TS22-E
	★ T1011.16R-TS22	22	1,000	1,000	1,250	6,000	1,300	
	★ T1011.20R-TS22	22	1,250	1,250	1,500	6,000	1,417	
<p>Square shank</p>	★ T1011.08L-TS16	16	0,500	0,500	0,625	4,000	0,900	TS16-E
	★ T1011.10L-TS16	16	0,625	0,625	0,750	4,000	0,900	
	★ T1011.16L-TS16	16	1,000	1,000	1,250	6,000	1,100	
	★ T1011.20L-TS16	16	1,250	1,250	1,500	6,000	1,100	TS22-E
	★ T1011.16L-TS22	22	1,000	1,000	1,250	6,000	1,300	
	★ T1011.20L-TS22	22	1,250	1,250	1,500	6,000	1,300	

The toolholders listed are designed for an inclination angle of 1° | Refer to the Walter online catalogue for more product information: [www.walter-tools.com](http://www.walter-tools.com) | Bodies and assembly parts are included in the scope of delivery

Assembly parts	Type $h = h_1$ [inch]	TS16-E 0,5–0,625	TS16-E 1–1,25	TS22-E 1–1,25
	Clamp		PK273	PK274
	Clamp set	PK275-SET		
	Clamping screw		FS2687 (T15IP) 1,844 lbs	FS2688 (T20IP) 2,876 lbs
	Shim	GX16-1	GX16-1	NX22-1
	Screw for shim	FS2590 (T9IP)	FS2590 (T9IP)	FS2686 (T15IP)
	Tension spring		FS1470	SP1000-76-16
	Torx key	FS1465 (T15IP)	FS1465 (T15IP)	
	Allen key			FS1464 (T20IP)

Accessories			
	Type	TS16-E	TS22-E
	Shim	MX16-1	MX22-1
	Shim	GX16-0	NX22-97.5
	Shim	GX16-2	NX22-98.5
	Shim	GX16-3	NX22-99.5
	Shim	GX16-4	NX22-0.5
	Shim	GX16-98	NX22-1.5
	Shim	GX16-99	NX22-0
	Shim		NX22-2
	Shim		NX22-3
	Shim		NX22-4

## Shank tool – External thread

 T1011...-S inch

A3

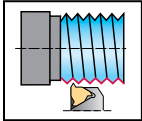
**Tool**







Designation		h = h <sub>1</sub> inch	b inch	f inch	l <sub>1</sub> inch	l <sub>4</sub> inch	Type
★ T1011.08R-TS16-S	16	0,500	0,500	0,500	5,000	0,84	TS16-E
★ T1011.10R-TS16-S	16	0,625	0,625	0,625	5,000	0,84	
★ T1011.12R-TS16-S	16	0,750	0,750	0,750	5,000	0,900	
<p>Square shank</p>							
★ T1011.12L-TS16-S	16	0,750	0,750	0,750	5,000	0,900	TS16-E
<p>Square shank</p>							

The toolholders listed are designed for an inclination angle of 1° | Refer to the Walter online catalogue for more product information: [www.walter-tools.com](http://www.walter-tools.com) | Bodies and assembly parts are included in the scope of delivery

**Assembly parts**

	Type h = h <sub>1</sub> [inch]	TS16-E 0,5–0,625	TS16-E 0,75
	Clamp		PK273
	Clamp set	PK275-SET	
	Clamping screw		FS2687 (T15IP) 1,844 lbs
	Shim	GX16-1	GX16-1
	Screw for shim	FS2590 (T9IP)	FS2590 (T9IP)
	Tension spring		FS1470
	Torx key	FS1465 (T15IP)	FS1465 (T15IP)

## Accessories

	Type	TS16-E
	Shim	MX16-1
	Shim	GX16-0
	Shim	GX16-2
	Shim	GX16-3
	Shim	GX16-4
	Shim	GX16-98
	Shim	GX16-99

A3

## Turning tools – External thread

 T1011-C... 

A3

– Walter Capto™

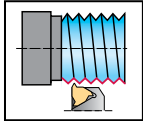













Tool	Designation		d <sub>1</sub>	f mm	l <sub>4</sub> mm	Type	
  Walter Capto™ in acc. with ISO 26623	★ T1011-C3R-22045-TS16	16	C3	22	45	TS16-E	
	★ T1011-C4R-27050-TS16	16	C4	27	50		
	★ T1011-C5R-35060-TS16	16	C5	35	60		
	  Walter Capto™ in acc. with ISO 26623	★ T1011-C6R-45065-TS16	16	C6	18	65	TS22-E
		★ T1011-C4R-27050-TS22	22	C4	27	50	
		★ T1011-C5R-35060-TS22	22	C5	35	60	
  Walter Capto™ in acc. with ISO 26623		★ T1011-C6R-45065-TS22	22	C6	45	65	TS16-E
		★ T1011-C4L-27050-TS16	16	C4	27	50	
		★ T1011-C5L-35060-TS16	16	C5	27	60	
	  Walter Capto™ in acc. with ISO 26623	★ T1011-C6L-45065-TS16	16	C6	35	65	TS22-E
		★ T1011-C4L-27050-TS22	22	C4	27	50	
		★ T1011-C5L-35060-TS22	22	C5	35	60	
  Walter Capto™ in acc. with ISO 26623	★ T1011-C6L-45065-TS22	22	C6	45	65		

The toolholders listed are designed for an inclination angle of 1° | The maximum recommended coolant pressure is 80 bar (1160 psi) | Refer to the Walter online catalogue for more product information: [www.walter-tools.com](http://www.walter-tools.com) | Bodies and assembly parts are included in the scope of delivery

Assembly parts	Type d <sub>1</sub>	TS16-E C3	TS16-E C4–C6	TS22-E C4–C6
	Clamp	PK273	PK273	PK274
	Clamping screw Tightening torque	FS2687 (T15IP) 2,5 Nm	FS2687 (T15IP) 2,5 Nm	FS2688 (T20IP) 3,9 Nm
	Shim	GX16-1	GX16-1	NX22-1
	Screw for shim	FS2693	FS2590 (T9IP)	FS2686 (T15IP)
	Tension spring	FS1470	FS1470	SP1000-76-16
	Torx key	FS1465 (T15IP)	FS1465 (T15IP)	
	Allen key			FS1464 (T20IP)



## Accessories

	Type	TS16-E	TS22-E
	Shim	MX16-1	MX22-1
	Shim	GX16-0	NX22-97.5
	Shim	GX16-2	NX22-98
	Shim	GX16-3	NX22-99
	Shim	GX16-4	NX22-98.5
	Shim	GX16-98	NX22-99.5
	Shim	GX16-99	NX22-0.5
	Shim		NX22-1.5
	Shim		NX22-0
	Shim		NX22-2
	Shim		NX22-3
	Shim		NX22-4

A3

## Boring bar – Internal thread

 A...-NTS-I / S...-NTS-I 

## Walter NTS



A3

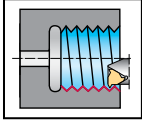

## Tool

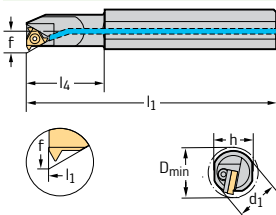



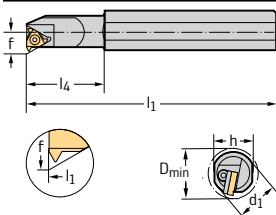

Parallel shank with clamping surface



Parallel shank with clamping surface

Designation		$D_{min}$ mm	$d_1$ mm	$f$ mm	$h$ mm	$l_1$ mm	$l_4$ mm	$\beta$	Type
A20Q-NTS-IL11-12		11	20	7,3	18	180	25	3°	NTS-I . -11 ..
A20Q-NTS-IL11-13		11	20	7,4	18	180	25	1,5°	
A20Q-NTS-IL11-16		11	20	8,9	18	180	32	1,5°	
A20Q-NTS-IR11-12		11	20	7,3	18	180	25	3°	
A20Q-NTS-IR11-13		11	20	7,4	18	180	25	1,5°	
A20Q-NTS-IR11-16		11	20	8,9	18	180	32	1,5°	
A20Q-NTS-IL16-16		16	20	10,2	18	180	32	2,5°	NTS-I . -16 ..
A20Q-NTS-IR16-16		16	20	10,2	18	180	34	2,5°	
S16M-NTS-IL16-20		16	16	11,3	15,2	150	32	1,5°	NTS-I . -16 ..
S16M-NTS-IR16-20		16	16	11,3	15,2	150	32	1,5°	
S20Q-NTS-IL16-17		16	20	10,3	18	180	32	1,5°	
S20Q-NTS-IL16-20		16	20	11,5	18	180	40	1,5°	
S20Q-NTS-IL16-24		16	20	13,4	18	180	40	1,5°	
S20Q-NTS-IR16-17		16	20	10,3	18	180	32	1,5°	
S20Q-NTS-IR16-20		16	20	11,5	18	180	40	1,5°	
S20Q-NTS-IR16-24		16	20	13,4	18	180	40	1,5°	
S25R-NTS-IL16-29		16	25	16,1	22,6	200	45	1,5°	
S25R-NTS-IR16-29		16	25	16,1	22,6	200	45	1,5°	
S32S-NTS-IL16-29		16	32	16,3	29	250	60	1,5°	NTS-I . -22 ..
S32S-NTS-IL16-36		16	32	19,6	29	250	60	1,5°	
S32S-NTS-IR16-29		16	32	16,3	29	250	60	1,5°	
S32S-NTS-IR16-36		16	32	19,6	29	250	60	1,5°	
S40T-NTS-IL16-44		16	40	23,8	25,8	300	60	1,5°	
S40T-NTS-IR16-44		16	40	23,8	25,8	300	60	1,5°	
S20Q-NTS-IL22-27		22	27	15,6	18	180	50	1,5°	
S25R-NTS-IL22-32		22	25	17,2	22,6	200	45	1,5°	
S25R-NTS-IR22-32		22	25	17,2	22,6	200	45	1,5°	
S32S-NTS-IL22-32		22	32	17,4	29	250	60	1,5°	
S32S-NTS-IL22-39		22	32	21,5	29	250	60	1,5°	
S32S-NTS-IR22-32		22	32	17,4	29	250	60	1,5°	
S32S-NTS-IR22-39		22	32	21,5	29	250	60	1,5°	
S40T-NTS-IL22-47		22	40	25,8	32	300	60	1,5°	
S40T-NTS-IR22-47		22	40	25,8	32	300	60	1,5°	

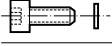
Bodies and assembly parts are included in the scope of delivery

Assembly parts		NTS-I. -11 .. 12-16	NTS-I. -16 .. 16-20	NTS-I. -16 .. 24-44	NTS-I. -22 .. 27	NTS-I. -22 .. 32-47
Type	D <sub>min</sub> [mm]					
	Left shim			YI3		YI4
	Right shim			YE3		YE4
	Clamping screw for threading insert Tightening torque	FS2174 (T8) 0,9 Nm	FS2175 (T10) 1,7 Nm	FS2177 (T10) 1,7 Nm	FS2176 (T20) 3,8 Nm	FS2178 (T20) 3,8 Nm
	Clamping screw + washer for shim			FS2179 (T10)		FS2180 (T20)
	Torx key	FS257 (T8)	FS1050 (T10)	FS1050 (T10)	FS256 (T20)	FS256 (T20)

A3

# Boring bar – Internal thread

S...-NTS-I inch

Walter NTS



A3

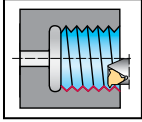

## Tool

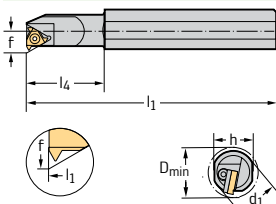

Parallel shank with clamping surface

Designation		$D_{min}$ inch	$d_1$ inch	$f$ inch	$h$ inch	$l_1$ inch	$l_4$ inch	$\beta$	Type
S10M-NTSIL16-51	16	0,800	0,625	0,460	0,580	6,000	1,250	1,5°	NTS-I . -16 ..
S10M-NTSIR16-51	16	0,800	0,625	0,460	0,580	6,000	1,250	1,5°	
S12Q-NTSIL16-46	16	0,800	0,750	0,460	0,670	7,000	1,500	1,5°	
S12Q-NTSIR16-40	16	0,670	0,750	0,400	0,670	7,000	1,250	1,5°	
S12Q-NTSIR16-46	16	0,800	0,750	0,460	0,670	7,000	1,500	1,5°	
S12Q-NTSIR16-51	16	0,900	0,750	0,510	0,670	7,000	1,500	1,5°	
S16R-NTSIL16-65	16	1,200	1,000	0,650	0,900	8,000	1,750	1,5°	
S16R-NTSIR16-65	16	1,200	1,000	0,650	0,900	8,000	1,750	1,5°	
S20S-NTSIL16-65	16	1,200	1,250	0,650	1,120	10,000	2,500	1,5°	
S20S-NTSIR16-65	16	1,200	1,250	0,650	1,120	10,000	2,500	1,5°	
S20S-NTSIR16-77	16	1,450	1,250	0,770	1,120	10,000	2,500	1,5°	
S24T-NTSIR16-90	16	1,650	1,500	0,900	1,340	12,000	2,500	1,5°	
S12Q-NTSIR22-59	22	1,000	0,750	0,590	0,670	7,000	2,000	1,5°	NTS-I . -22 ..
S16R-NTSIR22-71	22	1,250	1,000	0,710	0,900	8,000	1,750	1,5°	
S20S-NTSIR22-85	22	1,500	1,250	0,850	1,120	10,000	2,500	1,5°	
S24T-NTSIR22-98	22	1,750	1,500	0,980	1,340	12,000	2,500	1,5°	

Bodies and assembly parts are included in the scope of delivery

## Assembly parts

Type	$D_{min}$ [inch]	NTS-I . -16 .. 0,67–0,8	NTS-I . -16 .. 0,9–1,65	NTS-I . -16 .. 1,2	NTS-I . -22 .. 1	NTS-I . -22 .. 1,25–1,75
	Left shim			YI3		
	Right shim		YE3	YE3		YE4
	Clamping screw for threading insert Tightening torque	FS2175 (T10) 1,254 lbs	FS2177 (T10) 1,254 lbs	FS2177 (T10) 1,254 lbs	FS2176 (T20) 2,803 lbs	FS2178 (T20) 2,803 lbs
	Clamping screw + washer for shim		FS2179 (T10)	FS2179 (T10)		FS2180 (T20)
	Torx key	FS1050 (T10)	FS1050 (T10)	FS1050 (T10)	FS256 (T20)	FS256 (T20)

## Boring bar – Internal thread

C...-NTS-SI 

## Walter NTS

- Standard position
- Walter Capto™

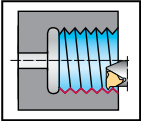

A3

## Tool

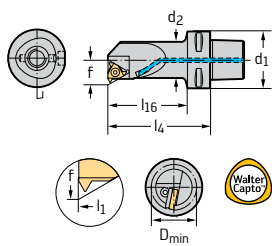

Walter Capto™ in acc. with ISO 26623

Designation		$D_{min}$ mm	$d_2$ mm	$d_1$	f mm	$l_4$ mm	$l_{16}$ mm	Type
C4-NTS-SIL22090-16	16	40	32	C4	22	90	69	NTS-I . -16 ..
C4-NTS-SIR22090-16	16	40	32	C4	22	90	69	
C5-NTS-SIL22090-16	16	40	32	C5	22	90	68	
C5-NTS-SIR22090-16	16	40	32	C5	22	90	68	
C6-NTS-SIL22090-16	16	40	32	C6	22	90	64	
C6-NTS-SIR22090-16	16	40	32	C6	22	90	64	
C4-NTS-SIL27080-16	16	50	39,5	C4	27	80	60	NTS-I . -22 ..
C4-NTS-SIR27080-16	16	50	39,5	C4	27	80	60	
C5-NTS-SIL27105-16	16	50	40	C5	27	105	84	
C5-NTS-SIR27105-16	16	50	40	C5	27	105	84	
C6-NTS-SIL27105-16	16	50	40	C6	27	105	80	
C6-NTS-SIR27105-16	16	50	40	C6	27	105	80	
C6-NTS-SIL22090-22	22	40	31,5	C6	22	90	64	NTS-I . -22 ..
C6-NTS-SIR22090-22	22	40	31,5	C6	22	90	64	
C6-NTS-SIL27105-22	22	50	40	C6	27	105	80	
C6-NTS-SIR27105-22	22	50	40	C6	27	105	80	

The toolholders listed are designed for an inclination angle of 1.5° | Bodies and assembly parts are included in the scope of delivery

## Assembly parts

Type	NTS-I . -16 ..	NTS-I . -22 ..
Left shim	YI3	YI4
Right shim	YE3	YE4
Clamping screw for threading insert Tightening torque	FS2177 (T10) 1,7 Nm	FS2178 (T20) 3,8 Nm
Clamping screw + washer for shim	FS2179 (T10)	FS2180 (T20)
Torx key	FS1050 (T10)	FS256 (T20)

## Replaceable head – Internal thread

 T1820-Q...-P mm

## Walter NTS

- QuadFit
- Precision cooling

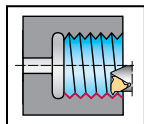







A3

Tool	Designation		$d_1$	$D_{min}$ mm	$f$ mm	$l_4$ mm	$\beta$	Type
	T1820-Q25R-16I-P	16	Q25	29	16,3	25	1°	NTS-I.. -16 ..
	T1820-Q32R-16I-P	16	Q32	36	19,8	32	1°	
	T1820-Q32R-22I-P	22	Q32	38	21,3	32	1°	NTS-I.. -22 ..
	T1820-Q40R-16I-P	16	Q40	44	23,8	32	1°	NTS-I.. -16 ..
	T1820-Q40R-22I-P	22	Q40	46	25,3	32	1°	NTS-I.. -22 ..
	T1820-Q50R-16I-P	16	Q50	54	28,8	32	1°	NTS-I.. -16 ..
	T1820-Q25L-16I-P	16	Q25	29	16,3	25	1°	NTS-I.. -16 ..
	T1820-Q32L-16I-P	16	Q32	36	19,8	32	1°	
	T1820-Q32L-22I-P	22	Q32	38	21,3	32	1°	NTS-I.. -22 ..
	T1820-Q40L-16I-P	16	Q40	44	23,8	32	1°	NTS-I.. -16 ..
	T1820-Q40L-22I-P	22	Q40	46	25,3	32	1°	NTS-I.. -22 ..
	T1820-Q50L-16I-P	16	Q50	54	28,8	32	1°	NTS-I.. -16 ..
T1820-Q50L-22I-P	22	Q50	56	30,3	32	1°	NTS-I.. -22 ..	

The maximum recommended coolant pressure is 150 bar (2175 psi) | Bodies and assembly parts are included in the scope of delivery

## Assembly parts

	Type	NTS-I.. -16 ..	NTS-I.. -22 ..
	Shim	GXA16-1	NXA22-1
	Clamping screw	FS2615 (T15IP)	FS2616 (T25IP)
	Lever	KN129	KN130
	Pin	RS123	RS124
	Torx key	FS1465 (T15IP)	
	Allen key		FS1592 (T25IP)

Accessories			
	Type	NTS-I . -16 ..	NTS-I . -22 ..
	Shim	GXA16-0	NXA22-0
	Shim	GXA16-2	NXA22-2
	Shim	GXA16-3	NXA22-3
	Shim	GXA16-4	NXA22-4
	Shim	GXA16-98	NXA22-98
	Shim	GXA16-99	NXA22-99

A3

A3

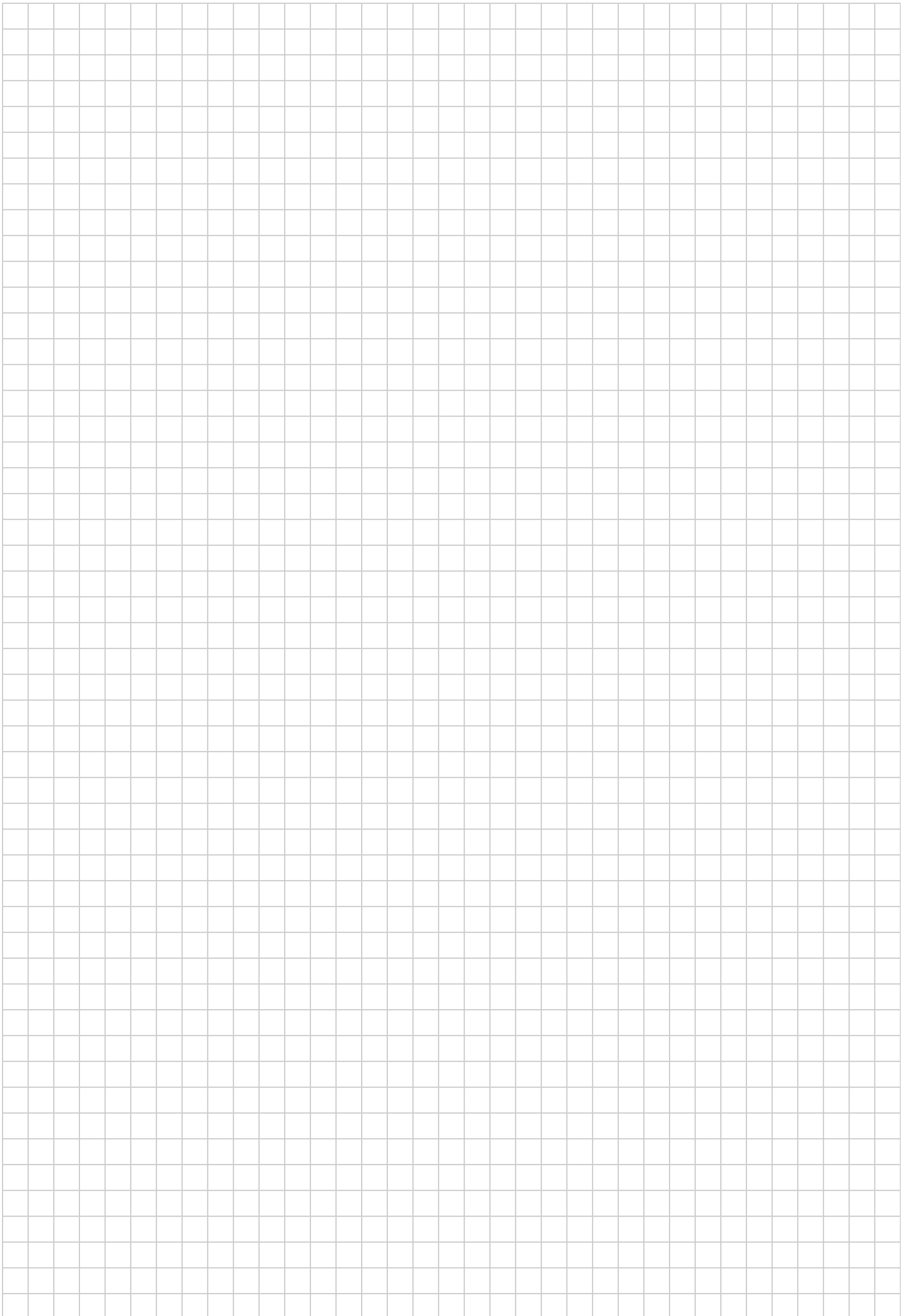



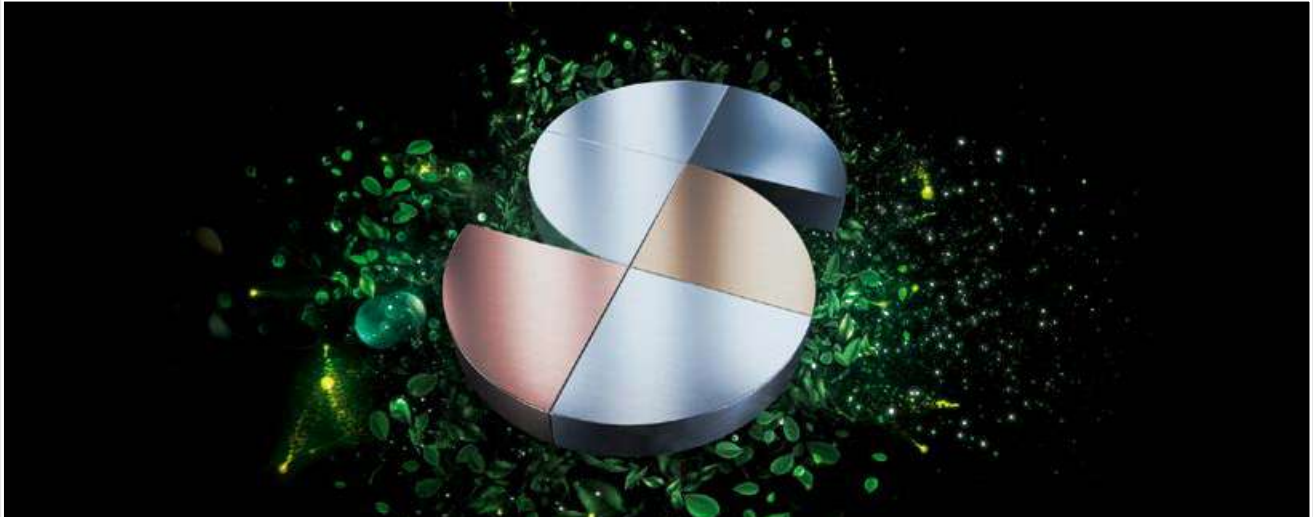

# Sustainable products and services – certified and transparent

Walter is a company that takes responsibility for people and the environment. Sustainability is a central component of our corporate strategy. It pervades our products and business divisions and is reviewed and certified by independent third parties on a regular basis.

## Proven to be produced to high standards

All processes, procedures, methods and instruments that we use are checked and certified by an independent body according to strict criteria. Occupational health and safety, quality assurance and environmentally friendly actions (e.g. through CO<sub>2</sub> compensation of our energy use) are examples of this. Our social commitment shows that Walter has a broader definition of responsibility.

## Transparency throughout the entire process chain – for your peace of mind

The integrated management system at Walter includes the sustainable use of resources and production equipment as well as of people – our customers, partners and employees. So that you can count on all of our products meeting these requirements throughout the entire process chain, we apply our own benchmarks to our suppliers too.

## Certification

The integrated management system at Walter includes certification in accordance with:

- ISO 9001 (Quality management)
- ISO 14001 (Environmental management)
- ISO 45001 (Occupational health and safety management)
- ISO 50001 (Energy management)
- Certified according to Ecovadis Gold Standard and NQC rating



You can find more information on Walter certification here:



### Occupational health and safety

Walter protects its employees against health hazards. To prevent accidents, we continuously review our processes and take proactive measures as a precaution.



### Environmental and energy management

Environmental protection is an important company objective for Walter. We use energy efficiently and deploy practical methods to sustainably reduce the consumption of energy, water and resources.



### Quality management

Walter is continuously improving its products and processes. We ensure our product quality using effective measures and procedures – and check it on a regular basis with our comprehensive quality management system.

## Walter AG

Derendinger Straße 53, 72072 Tübingen  
Postfach 2049, 72010 Tübingen  
Germany

walter-tools.com

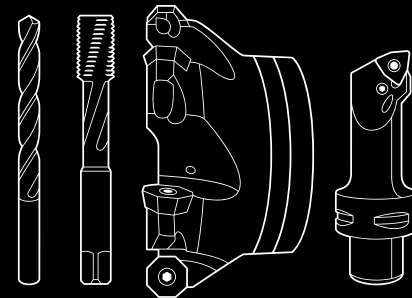

### Europe

#### Walter Austria GmbH

Wien, Österreich  
+43 1 5127300-0, service.at@walter-tools.com

#### Walter Benelux N.V./S.A.

Zaventem, Belgique  
(B) +32 (02) 7258500  
(NL) +31 (0) 900 26585-22  
service.benelux@walter-tools.com

#### Walter (Schweiz) AG

Solothurn, Schweiz  
+41 (0) 32 617 40 72, service.ch@walter-tools.com

#### Walter CZ s.r.o

Kurim, Czech Republic  
+420 (0) 541 423352, service.cz@walter-tools.com

#### Walter Deutschland GmbH

Tübingen, Deutschland  
+49 (0) 7071 701-400, service.de@walter-tools.com

#### Walter France

Soultz-sous-Forêts, France  
+33 (0) 3 88 80 20 00, service.fr@walter-tools.com

#### Walter Hungária Kft.

Budapest, Magyarország  
+36 1 464 7160, service.hu@walter-tools.com

#### Walter Tools Ibérica S.A.U.

El Prat de Llobregat, España  
+34 934 796760, service.iberica@walter-tools.com

#### Walter Italia s.r.l.

Via Volta, s.n.c., 22071 Cadorago - CO, Italia  
+39 031 926-111, service.it@walter-tools.com

#### Walter Norden AB

Halmstad, Sweden  
+46 (0) 35 16 53 00, service.norden@walter-tools.com

#### Walter Polska Sp. z o.o.

Warszawa, Polska  
+48 (0) 22 8520495, service.pl@walter-tools.com

#### Walter Tools SRL

Timisoara, România  
+40 (0) 256 406218, service.ro@walter-tools.com

#### Walter Tools d.o.o.

Maribor, Slovenija  
+386 (2) 629 01 30, service.si@walter-tools.com

#### Walter Slovakia, s.r.o.

Nitra, Slovakia  
+421 (0) 37 3260 910, service.sk@walter-tools.com

#### Walter Kesici Takımlar Sanayi ve Ticaret Ltd. Şti.

Bursa, Türkiye  
+90 (0) 224 909 5000 Pbx, service.tr@walter-tools.com

#### Walter GB Ltd.

Bromsgrove, England  
+44 (1527) 839 450, service.uk@walter-tools.com

### Asia

#### Walter Wuxi Co. Ltd.

Wuxi, Jiangsu, P.R. China  
+86 (510) 853 72199, service.cn@walter-tools.com

#### Walter Wuxi Co. Ltd.

中国江苏省无锡市新区新畅南路 3 号  
电话: +86-510-8537 2199 邮编: 214028  
客服热线: 400 1510 510  
邮箱: service.cn@walter-tools.com

#### Walter Tools India Pvt. Ltd.

Pune, India  
+91 (20) 6773 7300, service.in@walter-tools.com

#### Walter Japan K.K.

Nagoya, Japan  
+81 (52) 533 6135, service.jp@walter-tools.com

#### ワルタージャパン株式会社

名古屋市中村区名駅二丁目 45 番 7 号  
+81 (0) 52 533 6135, service.jp@walter-tools.com

#### Walter Korea Ltd.

Anyang-si Gyeonggi-do, Korea  
+82 (31) 337 6100, service.wkr@walter-tools.com

#### 한국발터(주)

경기도 안양시 동안구 학의로 282  
금강팬데리움 106호 14056  
+82 (0) 31 337 6100, service.wkr@walter-tools.com

#### Walter Malaysia Sdn. Bhd.

Selangor D.E., Malaysia  
+60(3)-5624 4265, service.my@walter-tools.com

#### Walter AG Singapore Pte. Ltd.

+65 6773 6180, service.sg@walter-tools.com

#### Walter (Thailand) Co., Ltd.

Bangkok, 10120, Thailand  
+66 2 687 0388, service.th@walter-tools.com

### America

#### Walter do Brasil Ltda.

Sorocaba – SP, Brasil  
+55 15 32245700, service.br@walter-tools.com

#### Walter Canada

Mississauga, Canada  
service.ca@walter-tools.com

#### Walter Tools S.A. de C.V.

El Marqués, Querétaro, México  
+52 (442) 478-3500, service.mx@walter-tools.com

#### Walter USA, LLC

Greer, SC, USA  
+1 800-945-5554, service.us@walter-tools.com